

GEMAS RANGER PUMPS



Product Details: Self-priming, monobloc - thermoplastic body, variable speed pool pump.

Technical Characteristic

- Connections are with unions; 1 ½ HP capacity: 2" (63mm) and 1 ½" (50 mm)
- Pump shaft in AISI 316 quality stainless steel. .
- Easy opening lid with 40° rate rotation
- Xylex lid option against aggressive chemicals for polycarbonate.
- 4,5 l pre-filter basket.
- Pump connection unions can be tightened and opened with 50 mm Gemas ball valve handle
- 3 speed options between 1400 and 2850 cycles.
- Factory settings: 1. Cycle-2100 rpm, 2. Cycle-2400 rpm, 3. Cycle-2850 rpm
- Permanent magnet – IP55 motor.
- Motors have single-phase input and soft start and shutdown feature.

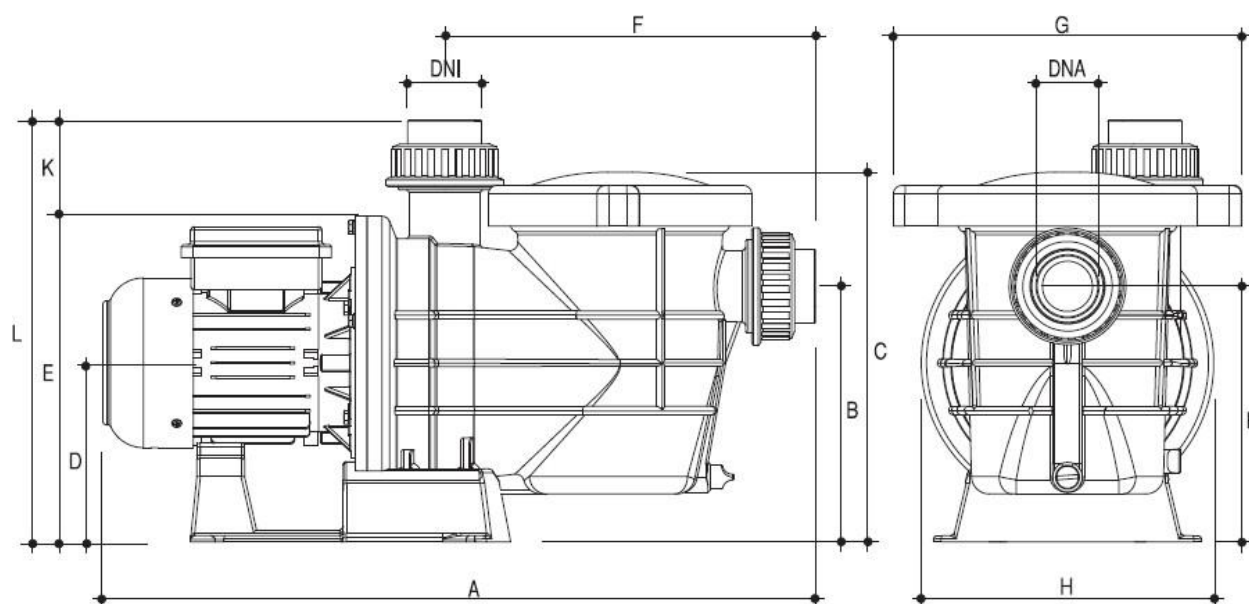

PUMP TYPE	DIMENSIONS												Net Weight (Kg)	Packaged Weight (Kg)
	DNA	DNI	A	K	B	C	D	E	F	G	H	I	Monophase	Monophase
0111RN150M	2"	1 1/2"	615	80	205	310	155	275	320	292	245	355	11.650	14.000
0111RN300M	2"	2"	730	80	205	310	145	275	320	292	245	355	17.400	19.050



VARIABLE SPEED MOTOR PERFORMANCE CURVES



"Pool Technology"

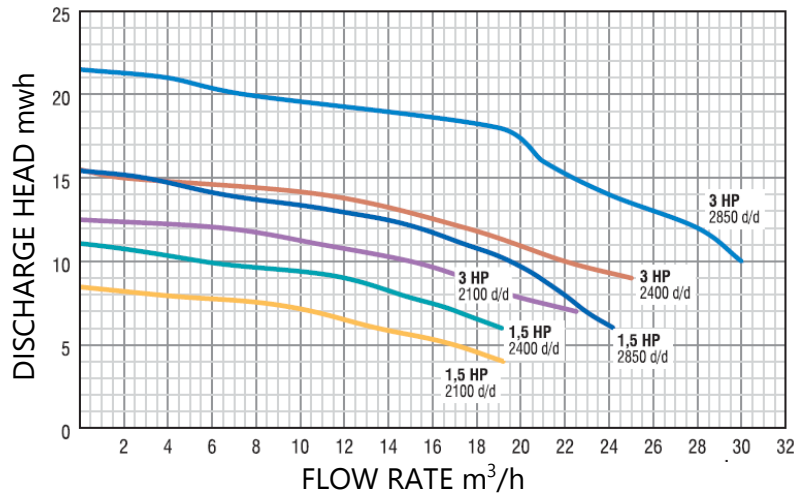

PUMP TYPE	HP	DISCHARGE HEAD mwh														
		4	5	6	7	8	9	10	11	12	13	14	15	16	17	17.5
0111RN150M	1.0	CAPACITY m³/h														
	2100 d/d	18.25	15.85	13.35	10.11	3.43	-	-	-	-	-	-	-	-	-	-
	2400 d/d			19.06	17.05	14.40	11.88	5.55	-	-	-	-	-	-	-	-
	2850 d/d			24.15	23.30	22.00	20.90	19.50	17.37	15.30	11.50	6.40	2.40	-	-	-
		AMPERE II 220 V														
	2100 d/d	2.5	2.4	2.2	1.6	1.3	-	-	-	-	-	-	-	-	-	-
	2400 d/d			3.5	3.5	3.4	3.0	2.4	1.7	-	-	-	-	-	-	-
	2850 d/d			6	5.9	5.9	5.8	5.9	5.6	5.4	4.9	4.1	3.3	2.9	-	-

PUMP TYPE	HP	DISCHARGE HEAD mwh														
		7	8	9	10	11	12	12.5	14	15	15.50	16	18	20	21	21.5
0111RN300M	3.0	CAPACITY m³/h														
	2100 d/d	22.50	19.50	17.50	15.00	11.00	6.50	-	-	-	-	-	-	-	-	-
	2400 d/d			25.00	22.00	-	17.50	-	11.00	2.00	-	-	-	-	-	-
	2850 d/d				30.00	-	28.00	-	24.00	-	-	21.00	19.00	7.50	4.00	-
		AMPERE II 220 V														
	2100 d/d	7.0	6.7	6.5	5.9	5.2	4.4	3.3	-	-	-	-	-	-	-	-
	2400 d/d			10.3	9.3	-	8.5	-	7.0	5.3	5.0	-	-	-	-	-
	2850 d/d				14.6	-	14.6	-	14.6	-	-	14.6	13.2	9.9	8.4	8.0

PUMP SUCTION PIPE DIMENSIONS

PUMP TYPE	0111RN150M	0111RN300M
Ø SUCTION PIPE	2 1/2" (Ø 75 mm)	3" (Ø 90 mm)

It is recommended to use conical reduction at the suction line of the pump.

