

SIDE CHANNEL BLOWERS

BL 090 001 – Single Impeller - Three Phase



Construction of the ring blowers fans is based on the lateral ducts principle. The blowers can operate as either exhaust or compression fans and are designed for continuous service. The device is assembled directly on the motor shaft; all the rotating parts are dynamically balanced to ensure absolute absence of vibration. Full die-cast aluminum construction for maximum sturdiness and ease of handling. The characteristics data given here refer to the handling of gas with inlet temperature of 15°C, normal density of 1,23 kg/m³ and absolute pressure of 1023 mbar. Tolerance of ±10%.

| Model | Freq. [Hz] | Power [kW] | Voltage [V] | | Rated Current [A] | | Max Airflow [m ³ /h] | Rated VACUUM [mbar] | Rated COMPRESSOR [mbar] | Noise [dB A] | Weight [kg] |
|---------------|------------|------------|-------------|---------|-------------------|------|---------------------------------|---------------------|-------------------------|--------------|-------------|
| | | | Δ | Y | Δ | Y | | | | | |
| BL09000108500 | 50 | 8.5 | 345÷415 | 600÷720 | 18.2 | 10.5 | 1050 | -190 | 190 | 74 | 93 |
| | 60 | 9.8 | 380÷480 | 660÷720 | | | 1250 | -150 | 140 | 79 | |
| BL09000112500 | 50 | 12.5 | 345÷415 | 600÷720 | 28.0 | 16.2 | 1050 | -290 | 280 | 74 | 116 |
| | 60 | 14.5 | 380÷480 | 660÷720 | | | 1250 | -270 | 260 | 79 | |
| BL09000115000 | 50 | 15 | 345÷415 | 600÷720 | 35.0 | 20.0 | 1050 | -320 | 380 | 74 | 120 |
| | 60 | 17.5 | 380÷480 | 660÷720 | | | 1250 | -340 | 360 | 79 | |
| BL09000118500 | 50 | 18.5 | 345÷415 | 600÷720 | 37.0 | 21.0 | 1050 | -360 | 460 | 74 | 126 |
| | 60 | 21.3 | 380÷480 | 660÷720 | | | 1250 | -380 | 420 | 79 | |

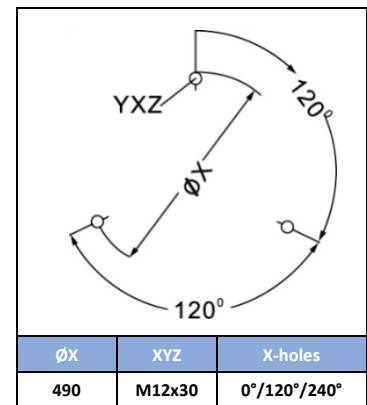
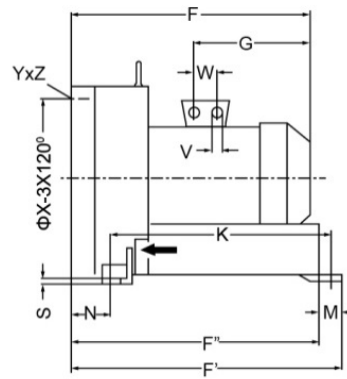
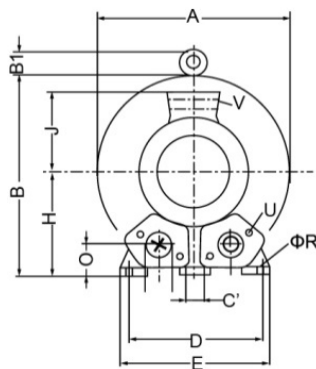
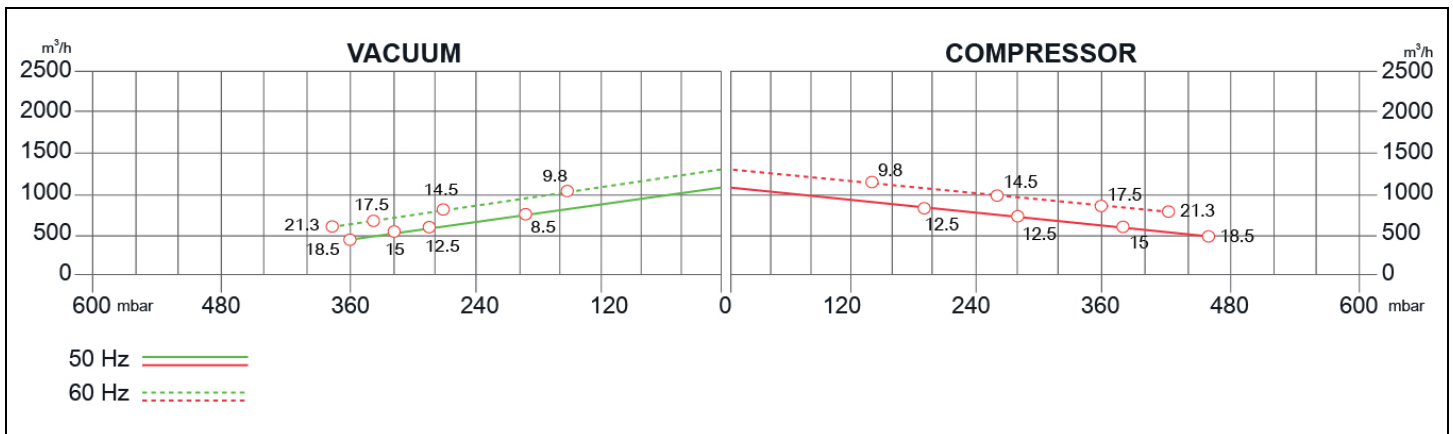

| MODEL | A | A' | B | B' | C | D | E | F | F' | G | H | H' | J | K | L | M | N | N' | O | ØR | S | U | V | W |
|---------------|-----|-----|----|-----|----|-----|-----|-----|-----|-----|-----|-----|-----|-----|----|----|----|-----|-----|----|----|--------|-----------|----|
| BL09000108500 | 550 | 569 | 55 | 207 | 15 | 360 | 415 | 525 | 644 | 605 | 268 | 300 | 167 | 533 | 39 | 89 | 92 | 100 | 150 | 15 | 21 | M12x30 | 4xM32x1.5 | 42 |
| BL09000112500 | 550 | 569 | 55 | 207 | 15 | 360 | 415 | 611 | 644 | 605 | 345 | 300 | 197 | 533 | 39 | 89 | 92 | 100 | 150 | 15 | 21 | M12x30 | 4xM32x1.5 | 54 |
| BL09000115000 | 550 | 569 | 55 | 207 | 15 | 360 | 415 | 611 | 644 | 605 | 345 | 300 | 197 | 533 | 39 | 89 | 92 | 100 | 150 | 15 | 21 | M12x30 | 4xM32x1.5 | 54 |
| BL09000118500 | 550 | 569 | 55 | 207 | 15 | 360 | 415 | 611 | 644 | 605 | 345 | 300 | 197 | 533 | 39 | 89 | 92 | 100 | 150 | 15 | 21 | M12x30 | 4xM32x1.5 | 54 |

Your Choice,
Our Commitment

Technical data can be changed without notice.

