

hibon[®]

Drybulk Truck Blowers

Truckstar series



IR **Ingersoll Rand**
Industrial Technologies

Truckstar Drybulk Truck Blowers

With over a century of experience in manufacturing positive displacement blowers, Ingersoll Rand, the worldwide leader in Three-Lobe technology, has developed a complete range of heavy-duty industrial units designed specifically for the toughest dry bulk transfer applications.

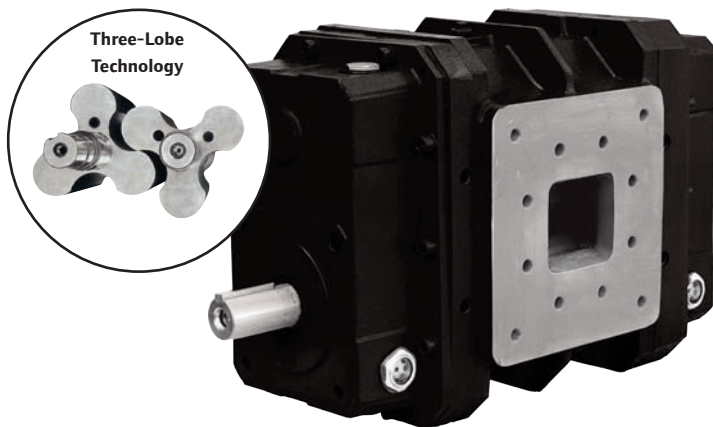

Compact, quiet and easy-to-install, Hibon Truckstar drybulk truck blowers are suitable for a wide range of applications in the toughest industries.



The innovative Three-Lobe design of the Truckstar series delivers unsurpassed reliability in a versatile unit that can be installed in nearly any drybulk transfer vehicle.

Dry Bulk Transfer Solutions

Hibon Truckstar Blowers integrate state-of-the-art Three-Lobe technology with a rugged compact design engineered specifically for the most demanding truck and transfer applications: Flour, animal food, pellets.

Innovative Three-Lobe Design

Truckstar is part of a new generation of proven Three-Lobe blowers that have taken the truck industry by storm. Superior performance and quiet operation together with unsurpassed reliability make Truckstar the blower of choice with fleet managers to operators in the dry bulk transfer industry. Truckstar is also pressure and vacuum capable.

Easy to Install

Truckstar was designed for ease of installation and can accommodate virtually any dry bulk transfer vehicle. Specify Truckstar as a replacement blower for an existing system or a complete Truckstar packaged system... experience the advantages of Three-Lobe technology.



Truckstar Drybulk Truck Blowers



Configurations Available

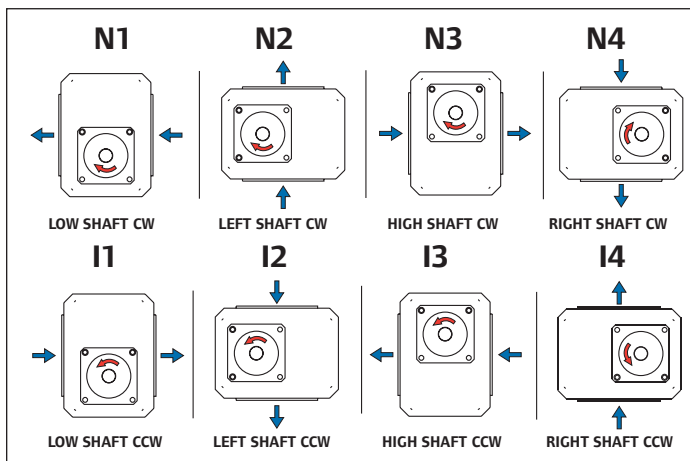

Construction Materials

Body	EN-GJL-200 Cast Iron
Head Plates	EN-GJ-200 Cast Iron
Oil Casing	AS-10-G-Y23 Cast Aluminum
Impellers	EN-GJS-400-15 Ductile Iron
Gears	Hardened Steel 42 CrMo4

Quiet, Efficient Operation

The combined action of Three-Lobe impellers and pulsation control ports delivers superior noise attenuation performance, as shown on this chart. Truckstar noise levels are typically 10 dB lower than two lobe competitors.

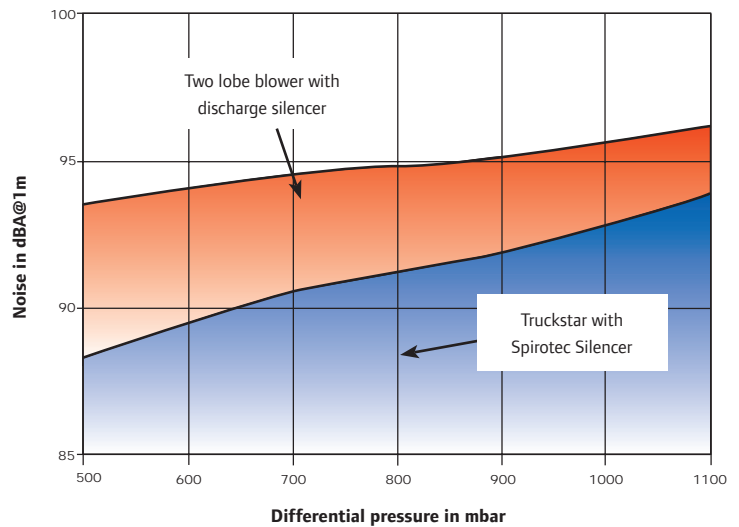

Features

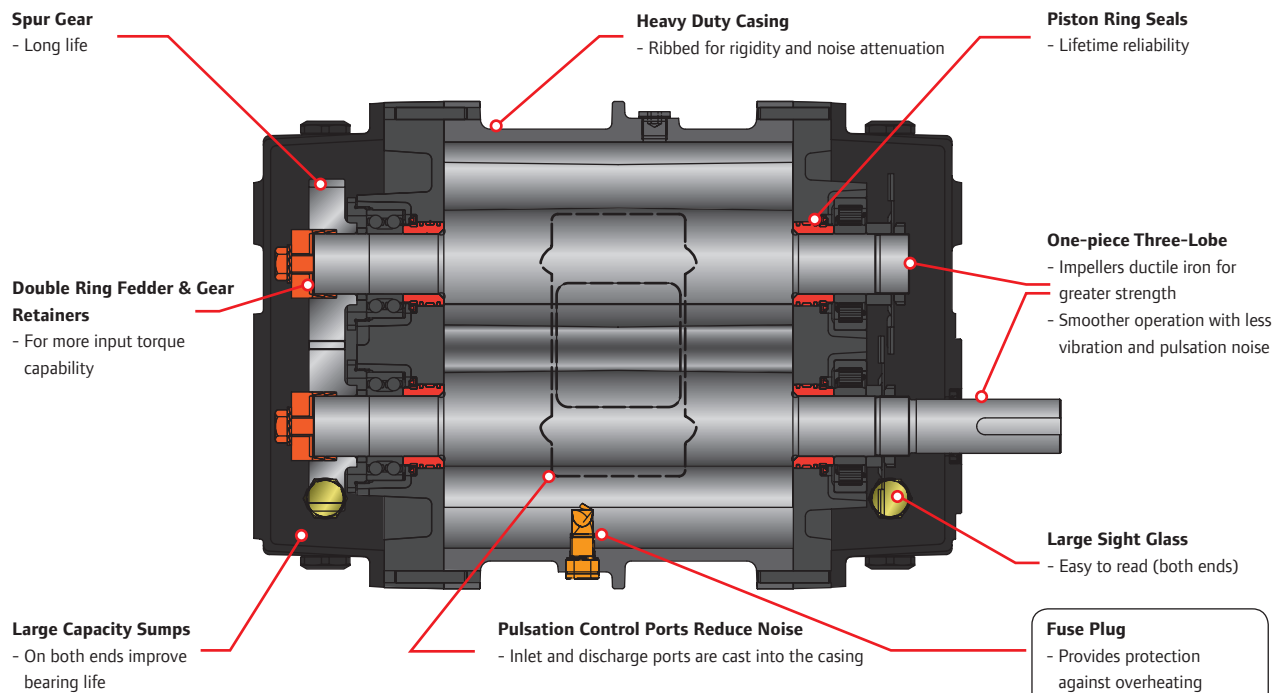

Dimensions Of Bare Shaft Units

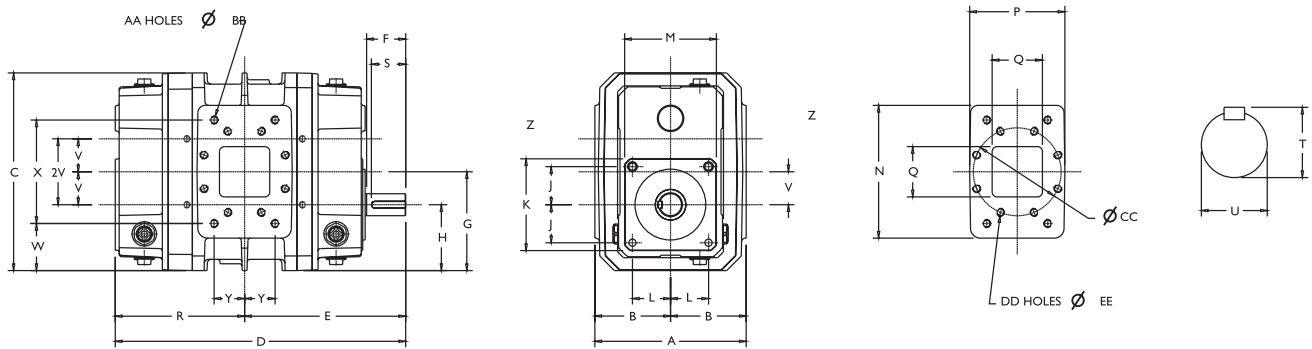

		A	B	C	D	E	F	G	H	J	K	L	M	N	P	R
TS 07	in	12.20	6.10	15.94	23.43	12.99	3.15	7.97	5.31	3.07	7.32	3.07	7.32	10.71	7.68	10.43
	mm	310	155	405	595	330	80	202.5	135	78	186	78	186	272	195	265
TS 10	in	12.20	6.10	15.94	26.46	14.51	3.15	7.97	5.31	3.07	7.32	3.07	7.32	10.71	10.71	11.95
	mm	310	155	405	672	368.5	80	202.5	135	78	186	78	186	272	272	303.5
		S	V	W	X	Y	T	U	Z	Q	AA	BB	CC	DD	EE	Weight
TS 07	in	2.76	2.66	3.8	9.13	2.66										337 lbs
	mm	70	67.5	96.5	232	67.5	48.5	45	100	103	4	M16	180	8	M16	153 kg
TS 10	in	2.76	2.66	3.8	8.35	3.98										357 lbs
	mm	70	67.5	96.5	212	101	48.5	45	100	103	4	M16	180	8	M16	162 kg

1) Metric dimensions are exact. 2) Imperial dimensions are conversion of metric. 3) Shaft and flange details are exact and metric.



Truckstar Drybulk Truck Blowers

Performance Pressure Operation

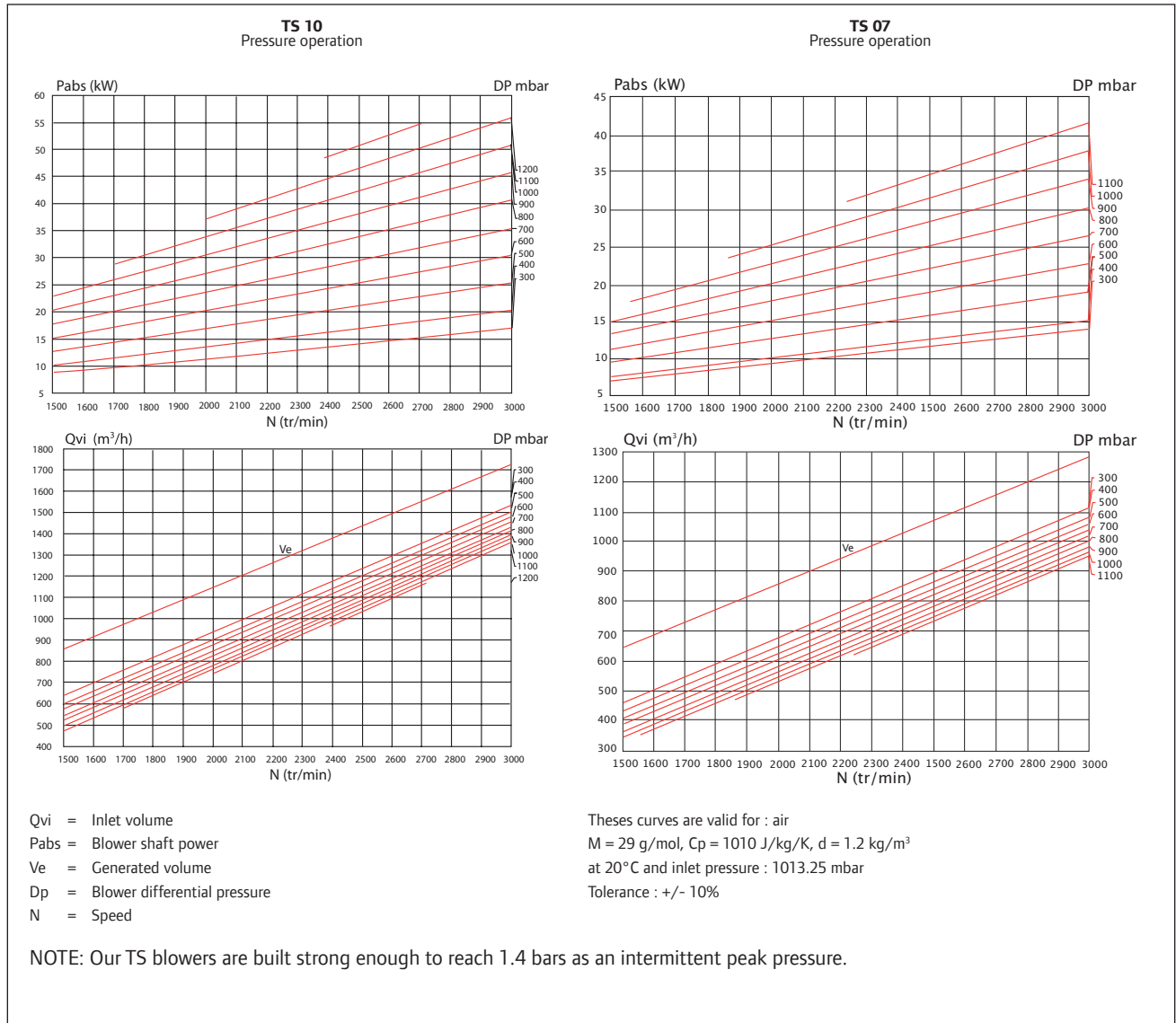

Accessories

Ingersoll Rand provides a range of accessories that are specifically designed for Higon Truckstar Blowers

- Inlet filter
- Inlet silencer
- Pressure gauge
- Discharge silencer
- Pressure relief valve
- Adaptor for hydraulic motor



Ingersoll Rand Industrial Technologies provides products, services and solutions that enhance our customers' energy efficiency, productivity and operations. Our diverse and innovative products range from complete compressed air systems, tools and pumps to material and fluid handling systems and environmentally friendly microturbines. We also enhance productivity through solutions created by Club Car®, the global leader in golf and utility vehicles for businesses and individuals.

