

**hibon**

# *Bareshaft Blowers*

**SN Three Lobe Series**



**IR** *Ingersoll Rand*  
Industrial Technologies

# Bareshaft Blowers SN Series

*Ingersoll Rand offers a wide range of positive displacement, three-lobe blowers for use in compression and vacuum applications for air and other neutral gases. The SN Series can deliver pressures to 1,1 bar (16 psig) and vacuum up to 500 mbar (15 "Hg) with flow rates from 15 m<sup>3</sup>/h (10 cfm) to 13500 m<sup>3</sup>/h (7950 cfm)*

## Experience and know-how

With almost a century of experience in the manufacture and sale of rotary positive displacement blowers, Ingersoll

Rand has a large range of three-lobe blowers specially designed to meet the demanding requirements of standard air or neutral gas applications: efficiency, competitiveness, and robustness.

This know-how ensures that the entire range of standard blowers benefits from the largest technological developments, allowing the user to obtain an optimum

solutions best suited to his needs.

## Benefits

- High mechanical and volumetric efficiency
- Reliability in operation
- Air-cooled, oil-free operation
- Fast and easy maintenance
- Dynamically balanced impellers
- Cast iron construction with a damper system to reduce noise and in-pipe pulsation
- Direct-drive or V-belt drive available throughout the operating range

## Application

Thousands of international installations of Ingersoll Rand blowers are proof of their reliability and strength, providing universal solutions in wide-ranging applications such as:

- Water treatment
- Pneumatic conveying
- Chemical, petrochemical and pharmaceutical
- Food processing
- Cement work
- Metallurgy
- Power
- Paper production, etc...

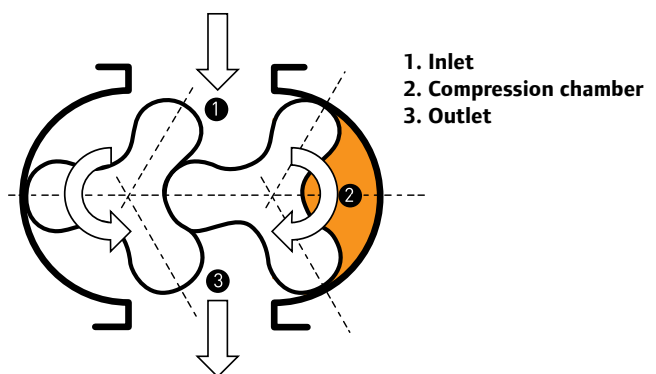

## Performance

Model	Max. Inlet Flow		Max. Differential Pressure		Max. Vacuum	
	m <sup>3</sup> /h	cfm	mbar	psig	mbar	"Hg
SN 801	300	175	1000	15	500	15
SN 802	450	270	1000	15	500	15
SN 803	650	380	1100	16	500	15
SN 804	850	500	1000	15	500	15
SN 806	1250	735	1100	16	500	15
SN 809	2000	1175	900	13	500	15
SN 811	2300	1350	1000	15	500	15
SN 817	3150	1850	1000	15	500	15
SN 822	4300	2530	800	12	500	15
SN 825	3200	1880	1100	16	500	15
SN 842	5000	2940	930	13	500	15
SN 855	7000	4100	1100	16	500	15
SN 870	8000	4700	900	13	500	15
SN 890	9000	5300	900	13	500	15
SN 8110	11000	6500	600	9	500	15
SN 8170	13500	7950	850	13	500	15



## Features

### 1. Bearings

- Lifespan calculation done per ISO281 standard for 50 000 hours L<sub>h10</sub>
- Five bearings<sup>1</sup> for improved reliability
- Suitable for all types of drive units including very compact transmissions
- Heavy-duty roller bearing at shaft end

### 2. Sealing

- Vented piston ring arrangement ensures reliable, oil-free operation.

### 3. Gears

- SN Series blowers are fitted with helical<sup>2</sup>, synchronised, ground gears manufactured to ISO Grade 6.
- Located at drive end for more input torque capability

### 4. Oil lubrication at both ends

- Two large-capacity cast iron oil casings
- Fins on casings ensure proper oil cooling

### 5. Rotors

- Three lobe design
- Integral rotors shaft for models SN 803, SN 804, SN 806, SN 809, SN 811, SN817, SN 822 (index MA)

### 6. Body

- Cast iron with damper system to reduce noise and downstream pulsation
- Detachable feet<sup>3</sup> allow mounting in vertical/horizontal position

### 7. Conforms to EC safety standard

<sup>1</sup> Except SN 801 and SN 802

<sup>2</sup> Blowers SN 801, SN 802, are fitted with spur gears located on driven end

<sup>3</sup> Except SN 8170



## Materials

Part	AFNOR	ASTM	DIN	EUROPEAN
Impeller case	FGL 200	A 48 gr 30 B	GG 20	EN – GJL 200
Heat plate covers	FGL 250	A 48 gr 35 B	GG 25	EN – GJL 250
Impeller	FGL 400-15	A 536 - 60 - 40 - 18	GGG 40	EN – GJL - 400 - 15
Shafts SN 803 to SN 822		A 536 - 60 - 40 - 18		EN – GJL - 400 - 15
Shafts SN 870 to SN 8170	42 CD 4	A 322 gr 4142	17200	42 Cr Mo 4
Shafts for others models (MA)	XC 48	A 304 gr 1045 H		C 45 E
Gears	42 CD 4	A 322 gr 4142	17200	42 Cr Mo 4

## Dimensions

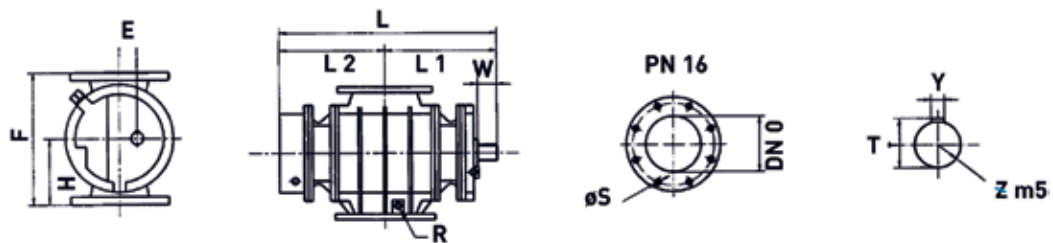

SN 801/802

SN Model	Units	E	F	H	L	L1	L2	DN 0	R	S	T	W	Y	Z	Weight
801	mm	36.25	270	135	378	196	182	80	1/4"G	M16	28	28	8	25	34 kg
	in.	1.43	10.63	5.31	14.88	7.72	7.17	3.15	1/4"G	M16	1.10	1.10	8mm	25mm	75 lb.
802	mm	36.25	270	135	476	246	230	80	1/4"G	M16	28	28	8	25	45 kg
	in.	1.43	10.63	5.31	18.74	9.69	9.06	3.15	1/4"G	M16	1.10	1.10	8mm	25mm	99 lb.



# Dimensions

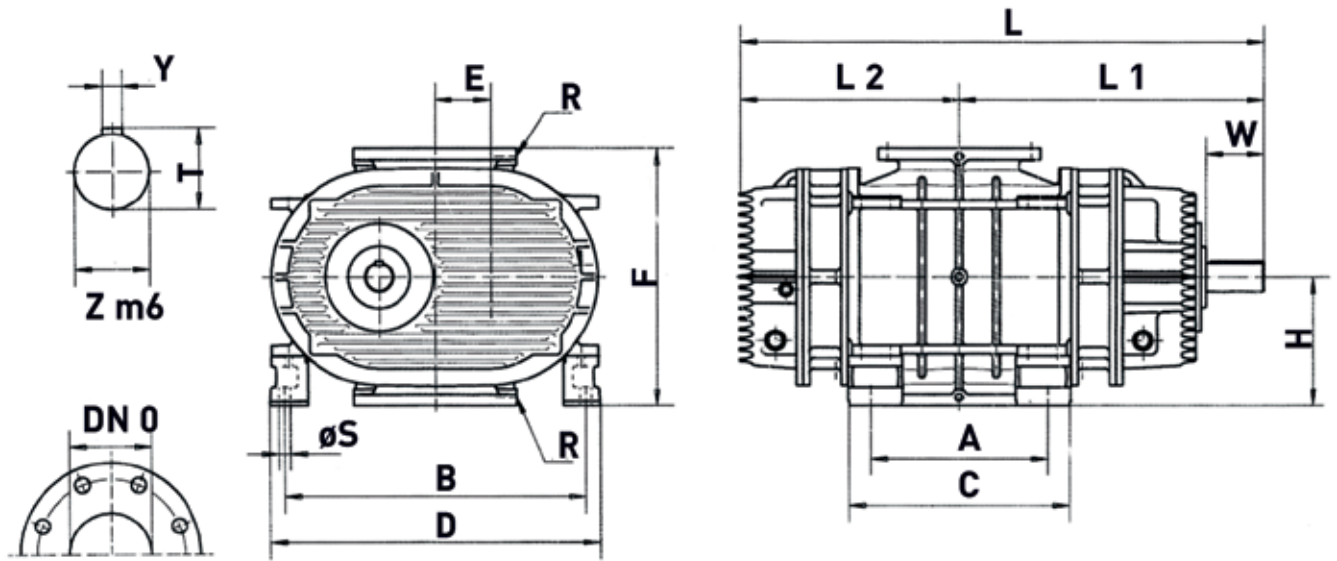

Type SN	Unit	A	B	C	D	E	F	H	L	L1	L2	DN 0	R	S	T	W	Y	Z	Weight
SN 803	mm	94	355	150	400	53	305	152.5	548	325	223	100	1/4"G	14	41	57.5	10	38	140 kg
	in.	3.70	13.98	5.91	15.75	2.09	12.01	6.00	21.57	12.80	8.78	3.94	1/4"G	0.55	1.61	2.26	10mm	38mm	309 lb.
SN 804	mm	154	355	210	400	53	305	152.5	608	355	253	100	1/4"G	14	41	57.5	10	38	150 kg
	in.	6.06	13.98	8.27	15.75	2.09	12.01	6.00	23.94	13.98	9.96	3.94	1/4"G	0.55	1.61	2.26	10mm	38mm	311 lb.
SN 806	mm	125	395	194	450	67.5	370	185	641	381	260	125	1/2"G	18	51.5	74.5	14	48	187 kg
	in.	4.92	15.55	7.64	17.72	2.66	14.57	7.28	25.24	15.00	10.24	4.92	1/2"G	0.71	2.03	2.93	14mm	48mm	412 lb.
SN 809	mm	205	395	274	450	67.5	370	185	721	421	300	150	1/2"G	18	51.5	74.5	14	48	209 kg
	in.	8.07	15.55	10.79	17.72	2.66	14.57	7.28	28.39	16.57	11.81	5.91	1/2"G	0.71	2.03	2.93	14mm	48mm	461 lb.
SN 811	mm	265	395	334	450	67.5	370	185	781	451	330	150	1/2"G	18	51.5	74.5	14	48	260 kg
	in.	10.43	15.55	13.15	17.72	2.66	14.57	7.28	30.75	17.76	12.99	5.91	1/2"G	0.71	2.03	2.93	14mm	48mm	573 lb.
SN 817	mm	240	550	312	600	86.5	450	225	862	511	351	200	1/2"G	22	64	100	18	60	434 kg
	in.	9.45	21.65	12.28	23.62	3.41	17.72	8.86	33.94	20.12	13.82	7.87	1/2"G	0.87	2.52	3.94	18mm	60mm	957 lb.
SN 822	mm	360	550	432	600	86.5	450	225	982	571	411	200	1/2"G	22	53.5	100	14	60	480 kg
	in.	14.17	21.65	17.01	23.62	3.41	17.72	8.86	38.66	22.48	16.18	7.87	1/2"G	0.87	2.11	3.94	14mm	60mm	1058 lb.
SN 825	mm	200	600	292	670	108.5	540	270	952	573	379	175	3/8"G	22	69	120	18	65	503 kg
	in.	7.87	23.62	11.50	26.38	4.27	21.26	10.63	37.48	22.56	14.92	6.89	3/8"G	0.87	2.72	4.72	18mm	65mm	1109 lb.
SN 842	mm	375	600	465	670	108.5	540	270	1127	660.5	466.5	250	3/8"G	20	69	120	18	65	620 kg
	in.	14.76	23.62	18.31	26.38	4.27	21.26	10.63	44.37	23.64	18.37	9.84	3/8"G	0.79	2.72	4.72	18mm	65mm	1367 lb.
SN 855	mm	305	730	409	800	135	620	310	1146	674.5	471.5	250	1/2"G	27	74.5	140	20	70	900 kg
	in.	12.01	28.74	16.10	31.50	5.31	24.41	12.20	45.12	26.56	18.56	9.84	1/2"G	1.06	2.93	5.51	20mm	70mm	1985 lb.
SN 870	mm	430	730	536	800	135	620	310	1271	737	534	250	1/2"G	27	74.5	140	20	70	1001 kg
	in.	16.93	28.74	21.10	31.50	5.31	24.41	12.20	50.04	29.02	21.02	9.84	1/2"G	1.06	2.93	5.51	20mm	70mm	2207 lb.
SN 890	mm	530	760	680	830	135	680	340	1421	812	609	445	1/2"G	25	74.5	140	20	70	1112 kg
	in.	20.87	29.92	26.77	32.68	5.31	26.77	13.39	55.94	31.97	23.98	17.52	1/2"G	0.98	2.93	5.51	20mm	70mm	2452 lb.
SN 8110	mm	680	760	830	830	135	680	340	1571	887	684	350	1/2"G	28	74.5	140	20	70	1226 kg
	in.	26.77	29.92	32.68	32.68	5.31	26.77	13.39	61.85	34.92	26.93	13.78	1/2"G	1.10	2.93	5.51	20mm	70mm	2703 lb.
SN 8170	mm	950	740	1080	840	170	910	380	1640	963	675	350	1/2"G	30	95	170	25	90	2500 kg
	in.	37.40	29.13	42.52	33.07	6.69	35.83	14.96	64.57	37.91	26.57	13.78	1/2"G	1.18	3.74	6.69	25mm	90mm	5513 lb.

# Cross section drawing

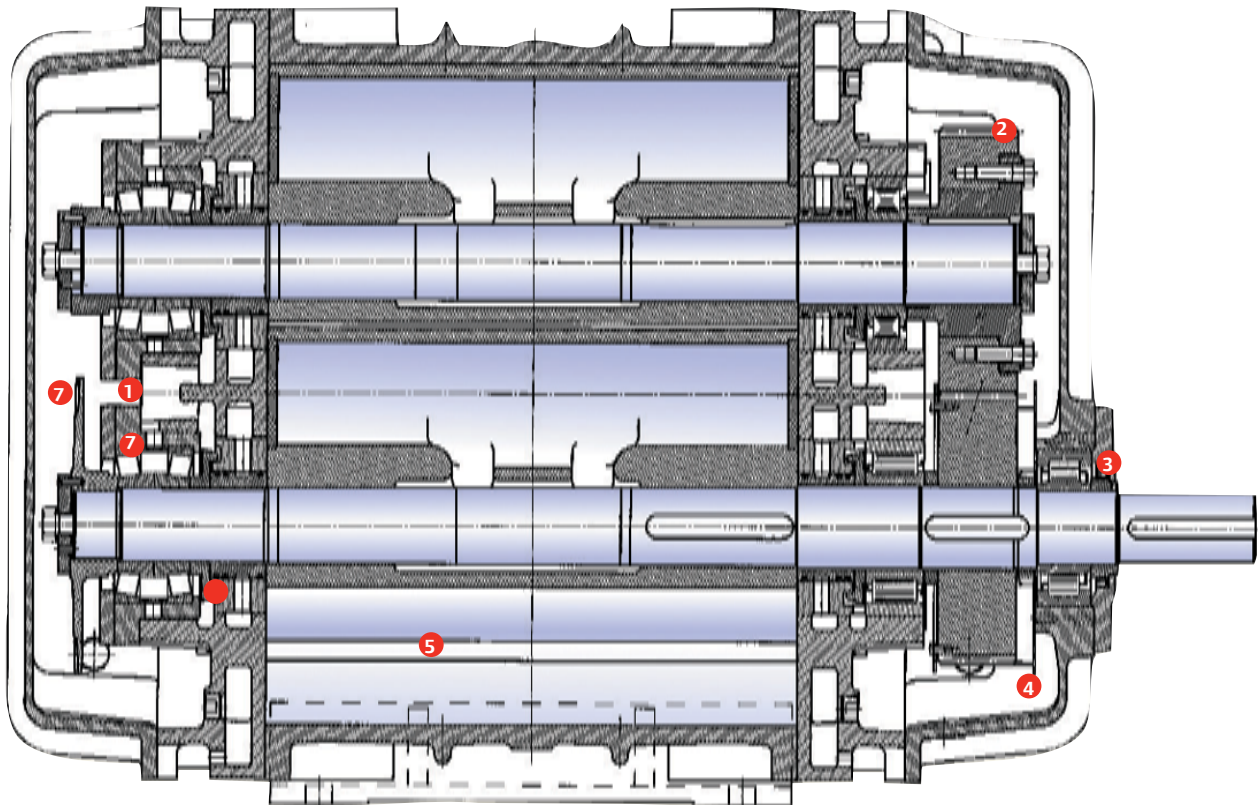

1. Heavy-duty bearing holders on thrust end for more axial load capability.
2. Helical gears located on the drive side for more input torque capability.
3. Five bearings including drive shaft roller bearings suitable for V-Belt and direct drives.
4. Large oil sumps for improved bearing lubrication.
5. Three lobes for smoother operation with less vibration and noise.
6. Piston ring seals for lifetime reliability.
7. Oil thrower and oil passages for good bearing lubrication & maximum life.



*All service work and repairs conform to the highest industrial standards and are completed by a team of experienced technicians and engineers. Ingersoll Rand embraces its duty to operate in a manner that protects the environment and human health and safety in order to support the company's long-term growth and reputation as a responsible corporation.*

#### **SERVICE AND PARTS**

##### **Ensure long-term, reliable operation**

- Global network of Certified Service Professionals
- Full on-site service packages available, including:
  - > Installation
  - > Commissioning
  - > Diagnostic
  - > Preventative maintenance
- Extensive spare parts inventory
- Operational and maintenance training programs

#### **STANDARD EXCHANGE PROGRAM**

##### **Factory Refurbished Machines**

- Large range of refurbished machines in stock
- Certified performance
- 12-month warranty

#### **PROFESSIONAL SALES & ENGINEERING SERVICES**

##### **We bring our expertise to you**

- More than a century of technical and industrial experience
- Global network of sales and application support personnel
- OEM customized drawings, manuals and documentation



Ingersoll Rand Industrial Technologies provides products, services and solutions that enhance our customers' energy efficiency, productivity and operations. Our diverse and innovative products range from complete compressed air systems, tools and pumps to material and fluid handling systems and environmentally friendly microturbines. We also enhance productivity through solutions created by Club Car®, the global leader in golf and utility vehicles for businesses and individuals.

