

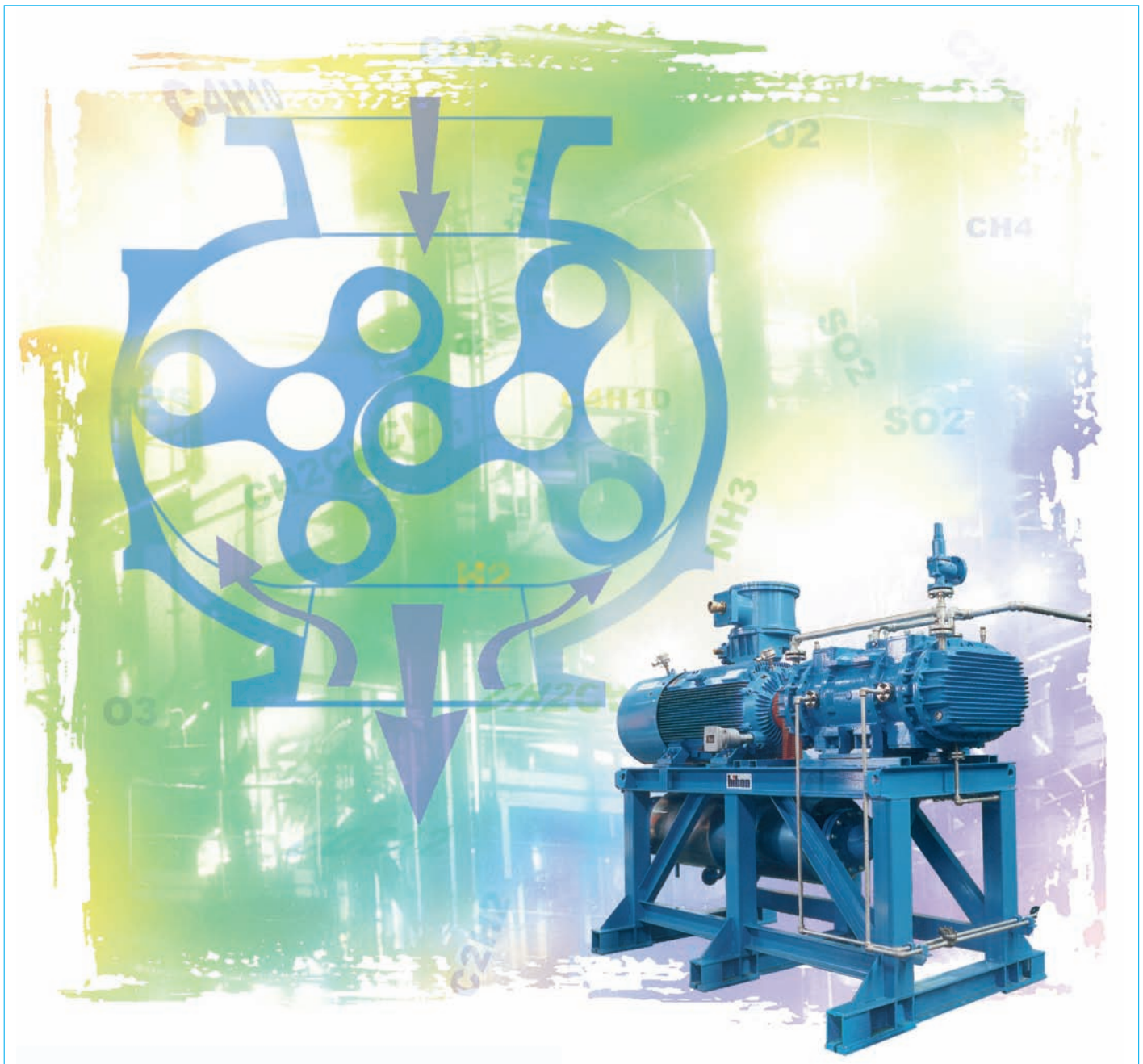

Surpresseurs Process *Process Blowers*



HIBON process blowers

Expérience et savoir-faire

Leader dans la fabrication et la commercialisation de surpresseurs à pistons rotatifs, la société HIBON dispose d'une large gamme de solutions pour le transfert de tous mélanges gazeux qu'ils soient dangereux, nocifs ou explosifs.

A l'écoute de vos préoccupations, elle met à votre disposition son savoir-faire pour étudier et réaliser des ensembles adaptés à vos besoins.

Dans un souci constant de recherche et de développement de matériaux, d'étanchéité et de configurations ou normes particulières.

Les surpresseurs PROCESS HIBON mondialement reconnus bénéficient d'une expérience de près d'un siècle qui leur confère les qualités de fiabilité et de robustesse exigées pour l'utilisation dans l'industrie chimique, parachimique, nucléaire, l'industrie du gaz, de l'énergie et de l'industrie du process...

Experience and Know-how

HIBON is a leader in the manufacturing and marketing of rotary piston blowers and offers a wide range of solutions for the transfer of all gas mixtures whether hazardous, harmful or explosive.

We offer you the know-how to evaluate and produce custom packages.

We are constantly researching and developing new materials, seals and configurations, and can offer you single or multi-stages blower system applicable solutions to match your specifications or special standards.

The HIBON PROCESS blowers are world renown and benefit from more than a century's experience, making them particularly reliable and rugged for use in the chemical, parachemical, nuclear, gas, energy and other process industries...

Principaux gaz

Gas compatibility chart

Gaz		Gas
Hydrogène	H2	Hydrogen
Oxygène	O2	Oxygen
Vapeur d'eau	H2O	Steam water vapour
Ozone	O3	Ozone
Oxyde de carbone	CO	Carbon monoxide
Gaz carbonique	CO2	Carbon dioxide
Phosgène	COCl2	Phosgene
Hydrogène sulfuré	H2S	Hydrogen sulphide
Anhydride sulfureux	SO2	Sulphur dioxide
Argon	Ar	Argon
Azote	N2	Nitrogen
Ammoniac	NH3	Ammonia
Méthane	CH4	Methan
Ethane	C2H6	Ethane
Propane	C3H8	Propane
Butane	C4H10	Butane
Acétylène	C2H2	Acetylen
Gaz naturel		Natural gaz
MCV	CH2CHCL	VCM
Biogaz		Biogas
Gaz de Haut Fourneau		Blast-furnace gas
Gaz de Four a Coke		Coke-oven gas
Tous mélanges gazeux		All gas mixture

MATÉRIAUX DE CONSTRUCTION ET NORMES DE FABRICATION

Afin de répondre aux exigences imposées par les gaz véhiculés, HIBON vous propose un choix important de matériaux (Fonte, Fonte Ni Résist, Bronze, Cupro-aluminium, Acier, Inox, Titane), et de revêtements (Métallisation, Ebonitage) ou de dépôt chimique (Kanigen, Nitruration), adaptés aux process et aux normes applicables.

CONSTRUCTION MATERIALS AND MANUFACTURING CODES

Because of the variety of gases being conveyed, HIBON offers a wide range of materials (Cast iron, Ni Resist Cast iron, Bronze, Aluminium/copper alloy, Carbon steel, Stainless steel, Titanium) and coating to meet your process requirement as well as international standards.

A wide range of process solutions

■ Gamme d'utilisation

Suivant l'utilisation en mono ou bi-étagés, la pression maxi de refoulement est respectivement de 0,9 bar (13 PSI) et 1,8 bar (26 PSI), en dépression de 50%.

L'échelonnement des cylindrées permet de générer des débits jusqu'à 25000 m³/h (14700 CFM).

■ Flow and pressure range

Depending upon whether the equipment is used in a single or two-stage configuration, the maximum discharge pressure is respectively **13 PSIG** (0,9 bar) or **26 PSIG** (1,8 bar). Negative pressure is 50%.

The range of process blowers produce flow-rates of up to **14 700 CFM** (25 000 m³/h).

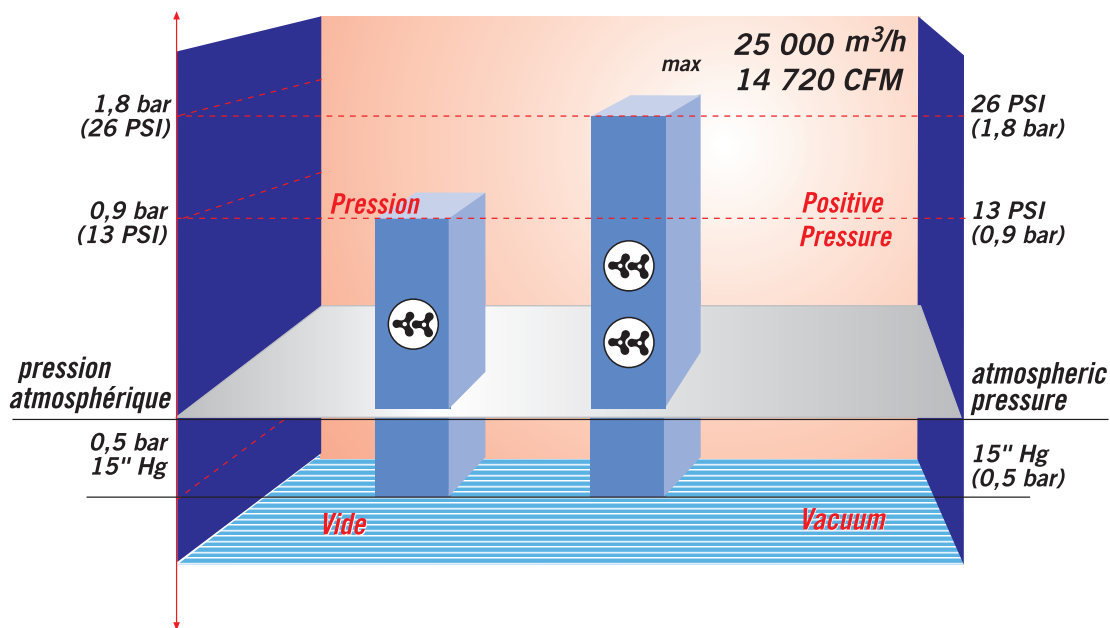

■ Contrôle qualité

Certifié **ISO 9001**, HIBON privilégie la qualité par la compétence de ses hommes et la performance de son outil de production. La construction de surpresseur PROCESS est soumise à un plan d'assurance Qualité qui s'applique tout aussi rigoureusement aux autres fournitures constitutives de l'ensemble livré.

Dans le cadre de réalisation sous plan qualité, nous fournissons également un dossier technique comprenant notes de calcul, certificat de conformité répondant aux normes ASTM, DIN, ISO et aux codes **ASME, API, CODAP, TEMA, TÜV, RINA...**



■ Quality control

ISO 9001 certified, HIBON ensures optimum quality through the skill of its employees and the performance of its production equipment.

The construction of the process blowers is subject to quality assurance plan applying with equal stringency to all the suppliers of the components used in the final equipment.

Within the framework of this quality plan production system, we also supply a technical data file including test data and conformity certificate meeting ASTM, DIN and ISO standards as well as **ASME, API, CODAP, TEMA, TÜV, RINA** standards.

Process blower for neutral gases

SN.S

Biogaz - N₂-AR-CH₄-H_e-H₂
et tout autre gaz non corrosif.

Biogaz, N₂-AR-CH₄-H_e-H₂
as well as any other non corrosive gas.

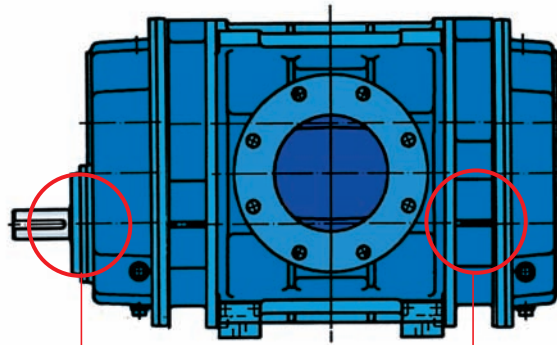

Etanchéité en sortie d'arbre
Shaft seal:

Etanchéité dans les plateaux
Main seals:

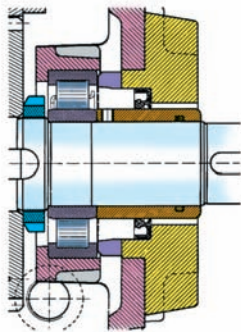

Etanchéité standard
Joint à lèvre
Standard:
lip seal

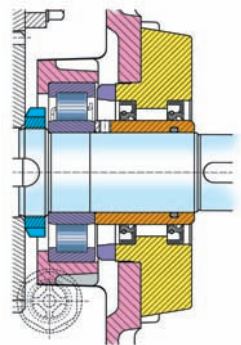

Etanchéité renforcée
2 Joints à lèvre
Improved sealing
Double lip seal

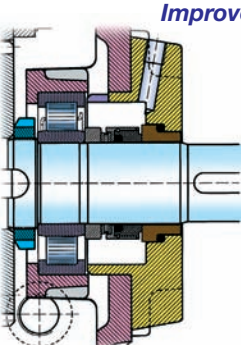

Garniture mécanique simple
Single mechanical seal

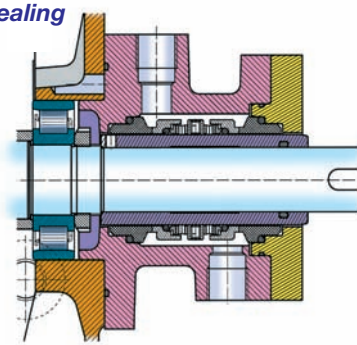

Garniture mécanique double
Double mechanical seal

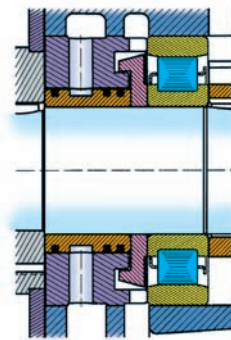

Gaz sec H₂ N₂
non corrosif
segments
Dry gas - H₂ N₂
non corrosive
Piston ring seals.

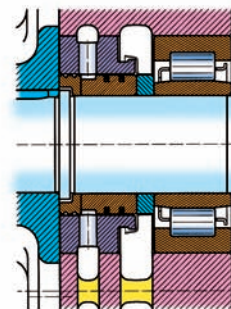

Pour gaz avec
barrage gaz neutre
segments + labyrinthe
Piston ring seals with
flushing connection
piston ring + labyrinth
seals

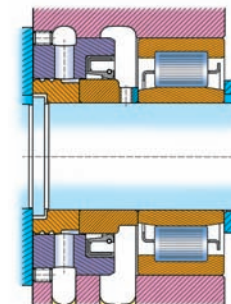

Gaz humide
Joint + labyrinthe
Wet gas
Lip seal + labyrinth seals

Applications :

- Transport pneumatique de polyéthylène
- Récupération méthane
- Dégazage (off gas)
- Refroidissement de fours (H₂ + N₂)
- Récupération d'hydrogène d'électrolyse

Applications:

- Pneumatic conveying of polyethylene
- Biogas recovery
- Degassing
- Furnace cooling
- Hydrogas recovery process.

Les gaz neutres sont définis comme compatibles avec la lubrification des organes de commande.
Neutral gases are defined as compatible with lubrication of gear train and bearings.

SURPRESSEUR POUR UTILISATION DE GAZ AGRESSIF OU DANGEREUX

Process Blower for aggressive and dangerous gases

SN.P

Garantit un gaz 100% sans huile même en cas de défaillance du système d'étanchéité

- O₂ - H₂ - O₃ - VCM - CO₂ - H₂S...
et tout autre gaz corrosif.

Guarantees 100% oil free gas even in the unlikely event of the sealing system failure

- O₂ - H₂ - O₃ - VCM - CO₂ - H₂S...
as well as any other corrosive gas.

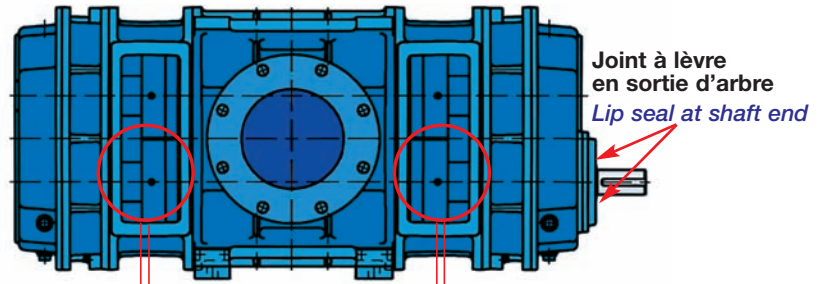

Etanchéité dans les plateaux Main seals

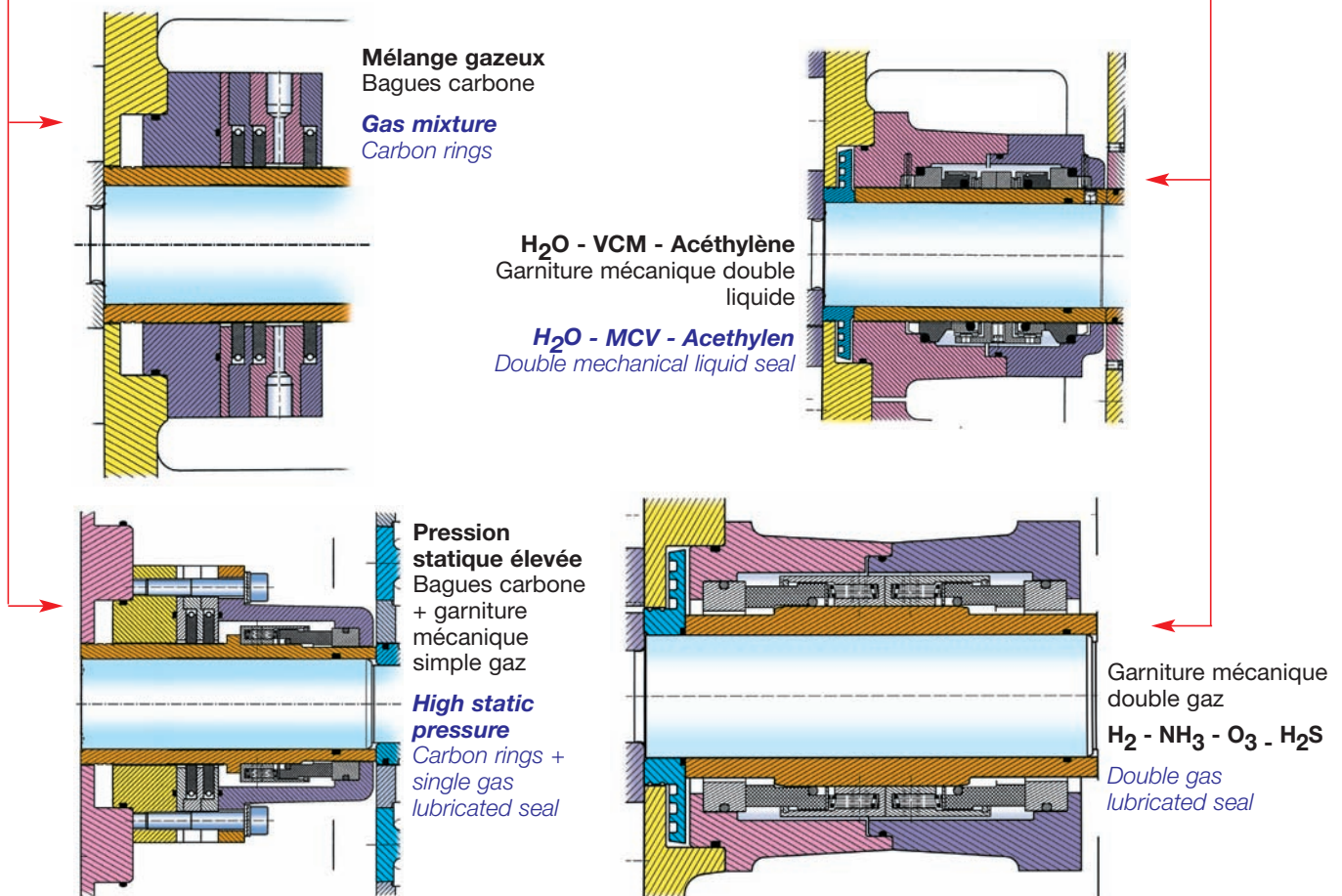

Applications :

- Récupération de gaz de haut fourneau
- Recirculation de gaz process
- Recompression mécanique de vapeur
- Hydrogénation
- Régénération de tamis moléculaire
- Transport d'oxygène en sortie V.S.A.
- Gaz de raffinage - Pétrochimie

Applications :

- Coke blast-furnace gas recovery
- Gas recycling
- Mechanical steam compression
- hydrogenation
- Compressor for molecular sieves regeneration
- transfert of oxygen, produced by V.S.A.
- Other Petro chemical applications...

A wide range of process solutions

Mise en groupe :

- HIBON conçoit, fabrique et assure la mise en groupe de ses Surpresseurs en accord avec les spécifications clients et les principales normes applicables dans le monde.

Package:

- HIBON designs, manufactures and packages blowers to meet customer specifications and international codes and standards.

Industrie du Plastique

Traitement thermique
Hydrogène et azote

Plastic Industry
Thermal treatment
Hydrogen and nitrogen



Traitement des boues

Récupération de biogaz
1100Nm³/h à 300 Nm³/h

Sludge treatment
Biogas recovery



Fabrication de gaz industriels

Transfert d'oxygène
produit par VSA
(Vacuum Swing Absorbers)
Débit : 3629 m³/h
Moteur : 132 Kw

**Industrial gases
manufacturing**
Transfer of oxygen produced
by a VSA
(Vacuum swing Absorber)
Flow: 3629 m³/h
Motor: 132 Kw

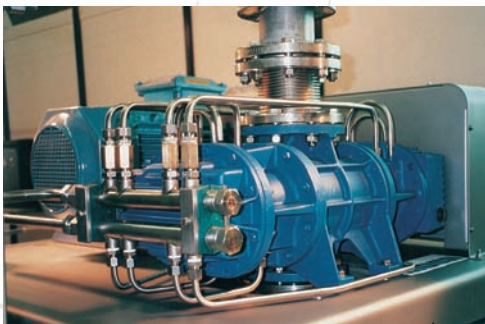

Construction d'évaporateurs

Distillation avec C.M.V.
Recompression mécanique de
vapeur dans une unité de distillation
d'eau pharmaceutique.
Débit : de 180kg/h à 1800kg/h

Evaporation Process
Double distillation process
with M.C.V. Mechanical recom-
pression at a pharmaceutical
distilled water plant.







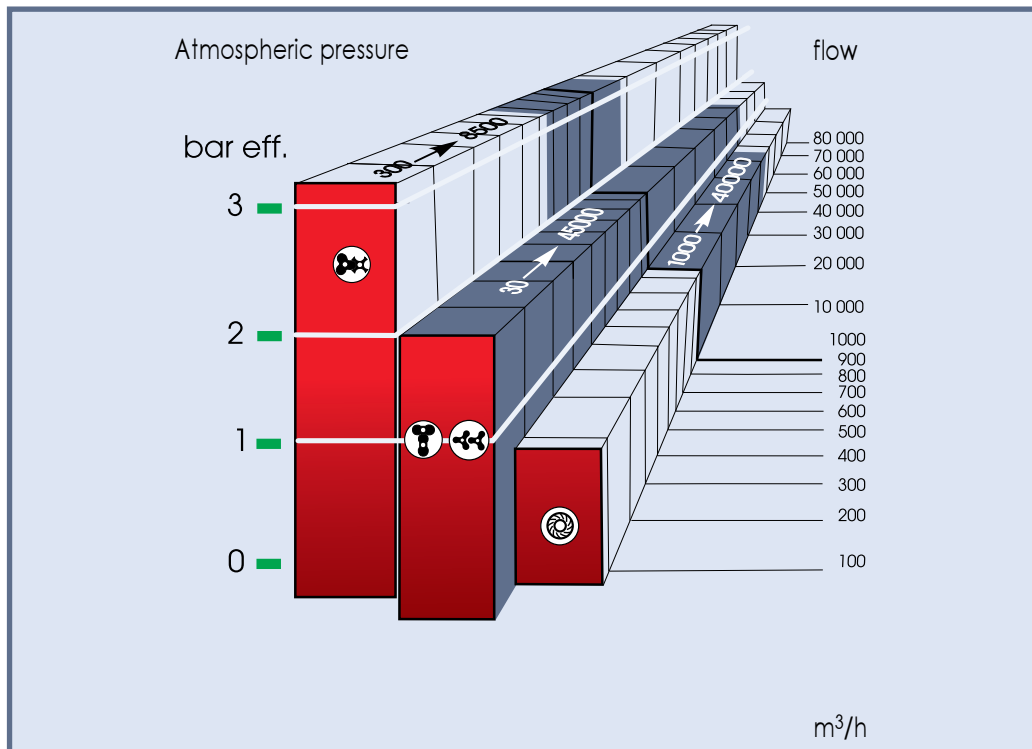

Complexe de fabrication d'éthylène acétylène

**Unit of ethylen manufacturing
acetylen.**



Other Solutions



	<p>Standard positive displacement blowers (bi-lobe and tri-lobe)</p>	
	<p>Multistage Centrifugal Blowers</p>	
	<p>Oil Free Screw Compressors</p>	



Ingersoll Rand Industrial Technologies provides products, services and solutions that enhance our customers' energy efficiency, productivity and operations. Our diverse and innovative products range from complete compressed air systems, tools and pumps to material and fluid handling systems and environmentally friendly microturbines. We also enhance productivity through solutions created by Club Car®, the global leader in golf and utility vehicles for businesses and individuals.

