

Technical Characteristics	
<ul style="list-style-type: none"> Aluminum alloy construction Smooth operation Maintenance free 	
Electric Motor	
<ul style="list-style-type: none"> Motors with IP 55 protection rating. class F insulation, suitable for operating with inverter (refer to FPZ) Thermal Protector (PTO) as standard 	
Options	
<ul style="list-style-type: none"> Special voltages (IEC 60038) Surface treatments Increased seal version 	

~3	[V] (Y / Δ)	[Hz]
IE2	690 / 400	50
	460 / 795	60
Wide Range	600 – 720 / 345 – 415	50
	660 – 830 / 380 – 480	60

Supply voltage - IE2 only at 50 Hz - Tolerance on the fixed voltage value ± 10%, in range ± 5%.

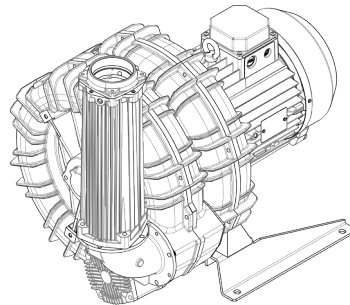

Performance Table

P _n [kW]	Frequency [Hz]	Δp _{max} [mbar]		Q _{max} [m³/h]	Leq ¹ [dB(A)]	Weight [kg]	H ³ [mm]	Current Consumption (Y/Δ) [A]		Cosφ [-]	Speed [rpm]
		Suction	Compression					IE2 ²	Range		
7.5	50	375	325	518	77	100.5	580	9.06 / 15.7	9.18-9.47 / 15.9-16.4	0.78	2940
9	60	325	290	625	79	100.5	580	8.86 / 15.34	9.87-9.00 / 17.1-15.6	0.83	3530
9.2	50	425	425	518	77	105.5	620	10.3 / 17.8	11.1-10.6 / 19.2-18.3	0.83	2940
11	60	425	390	625	79	112	620	10.3 / 17.9	11.9-10.3 / 20.6-17.9	0.86	3530
11	50	-	550	518	77	112	620	12.53 / 21.7	13.0-12.9 / 22.6-22.3	0.81	2940
13	60	-	490	625	79	112	620	12.2 / 21.2	13.8-12.4 / 23.9-21.4	0.84	3530
15	50	-	625	518	77	129	695	16.46 / 28.51	17.8-16.6 / 30.8-28.8	0.84	2940
17	60	-	625	625	79	129	695	15.7 / 27.2	18.1-15.6 / 31.3-27.1	0.86	3540

1. Noise level measured at a distance of 1 m with ducted intake and delivery, in accordance with Standard ISO 3744.
 2. IE2 only at 50 Hz.
 3. See figure "dimensions" at following page.

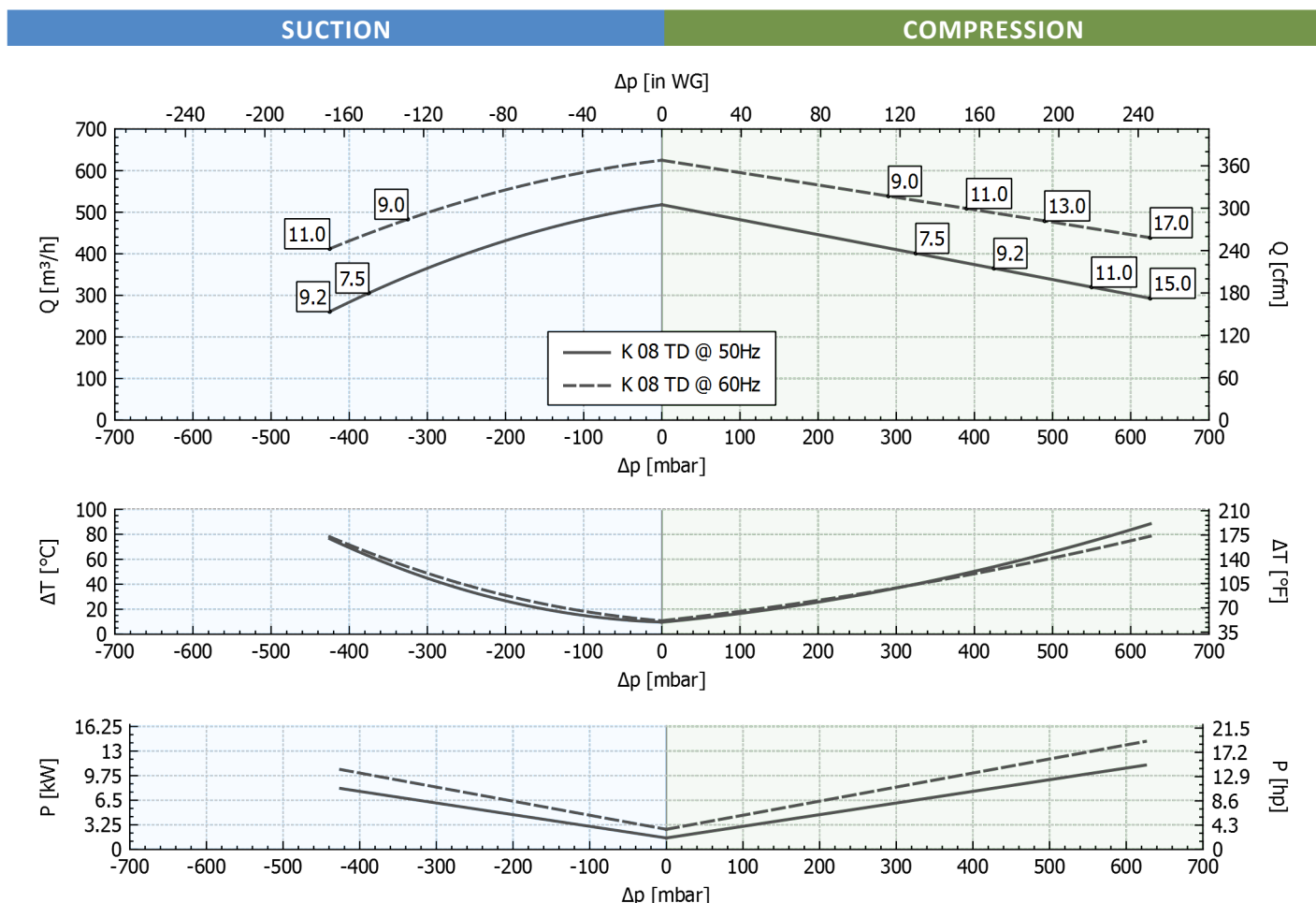

Tolerance on indicated values ± 10%.
 Data subject to change without notice.
 Curves referring to air at a temperature of 20 °C and atmospheric pressure of 1013 mbar (abs).

Dimensions

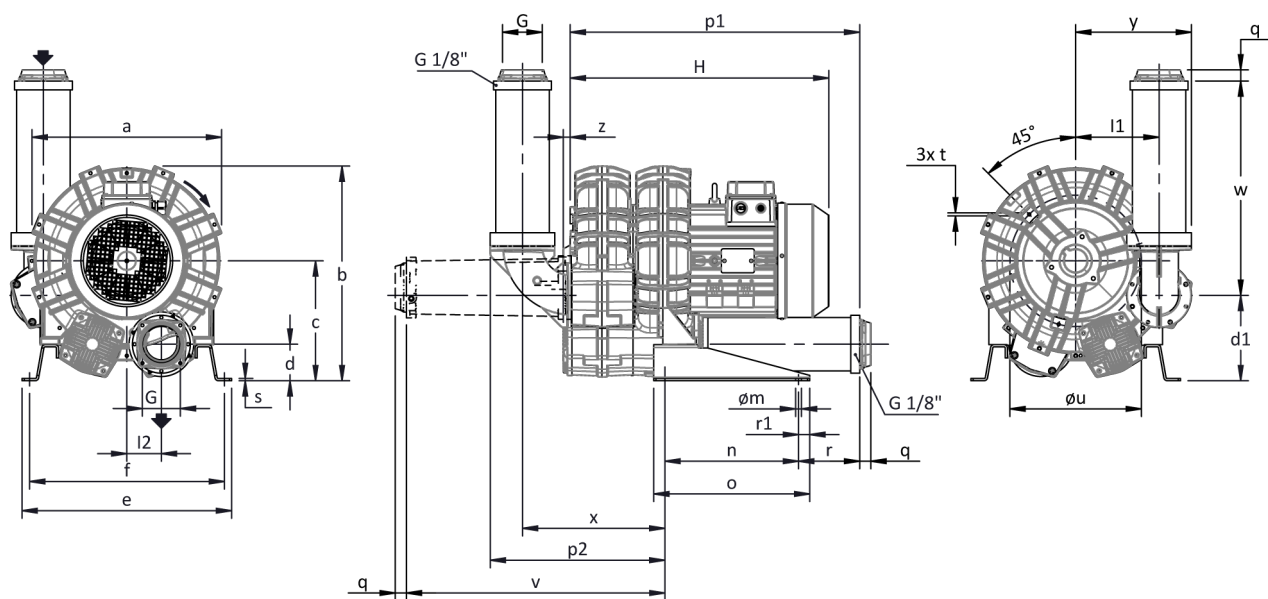

For all assembly options refer to FPZ.
 Dimensions in mm
 NOT Binding

a	b	c	d	d1	e	f	G	l	l1	l2	m	n	o	p1	p2	q	r	r1	s	t	u	v	w	x	y	z
457	498	269	82	192	480	448	G 3"	-	187	77.5	13	300	350	650	392	25	137	25	5	M8	310	581	481	319	260	16

INSTALLATION

- For proper operation of the machine, it must be provided with a suction FILTER and a vacuum/pressure limiting VALVE.
- Other accessories are available on request.
- Permissible ambient and fluid temperature in suction from -15 °C to +40 °C.
- Read the instruction manual carefully before installing the machine.