

Technical Characteristics
<ul style="list-style-type: none"> - Aluminum alloy construction - Smooth operation
Electric Motor
<ul style="list-style-type: none"> - Motors with IP 55 protection rating. - Class F(B) insulation - Thermal Protector (PTO) as standard
Options
<ul style="list-style-type: none"> - Special voltages (IEC 60038) - Surface treatments - Increased seal version

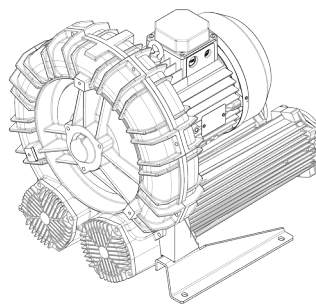

Performance Table

P _n [kW]	Frequency [Hz]	Δp _{max} [mbar]		Q _{max} [m ³ /h]	Leq ¹ [dB(A)]	Weight [kg]	H ² [mm]
		Suction	Compression				
4	50	160	160	536	76.5	61	477
4.6	60	100	100	647	78.5	61	477
5.5	50	220	220	536	76.5	72	535
6.3	60	200	200	647	78.5	72	535
7.5	50	275	325	536	76.5	77.5	535
8.6	60	275	300	647	78.5	77.5	535

1. Noise level measured at a distance of 1 m with ducted intake and delivery, in accordance with Standard ISO 3744.
2. See figure "dimensions" at following page.

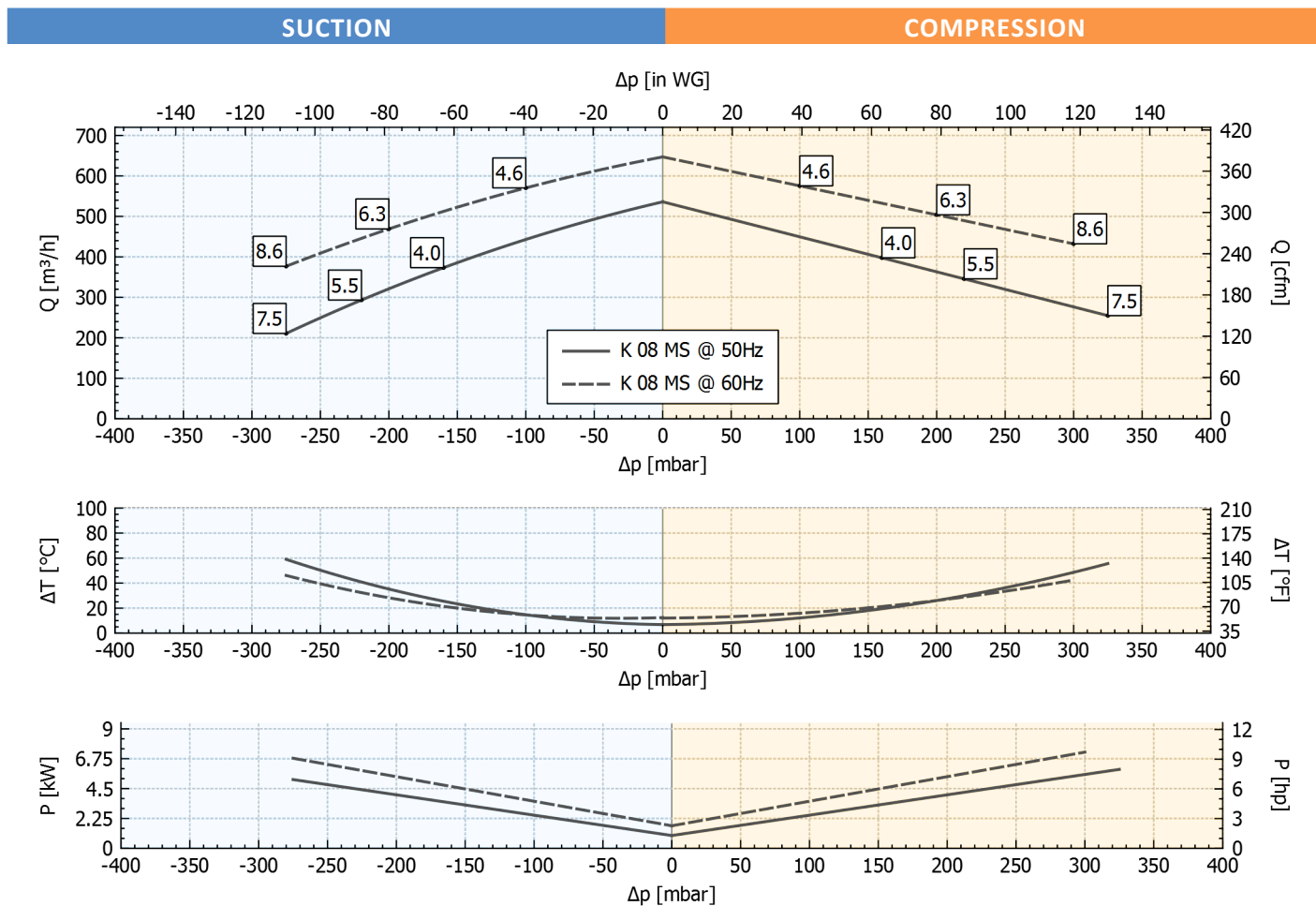

Tolerance on indicated values ± 10%.
Data subject to change without notice.
Curves referring to air at a temperature of 20 °C and atmospheric pressure of 1013 mbar (abs).

Dimensions

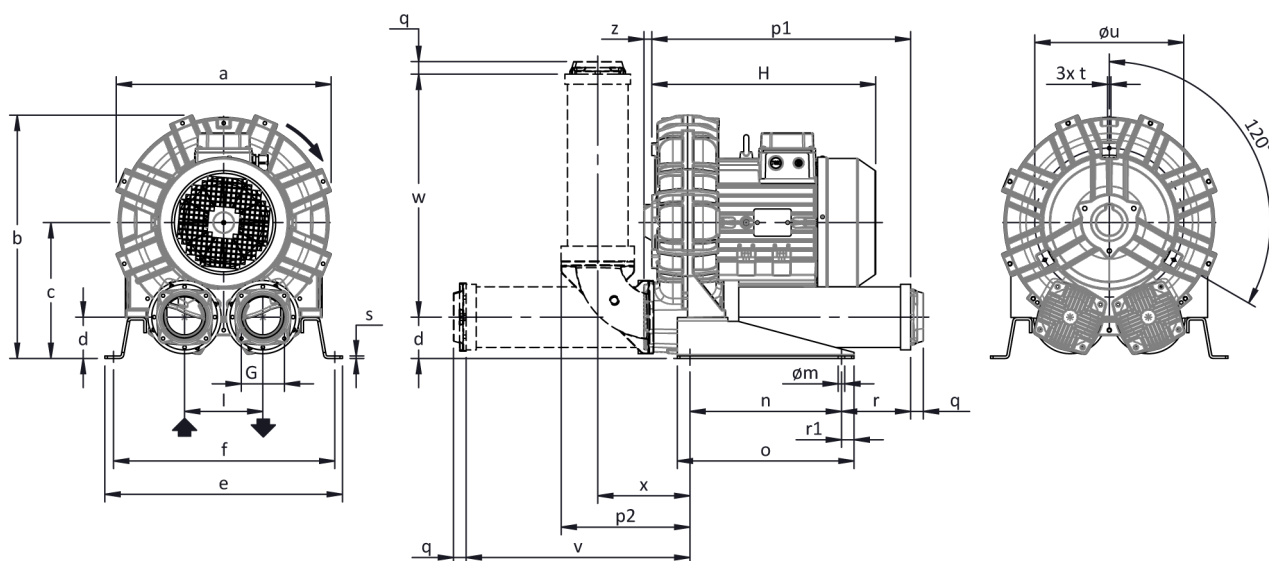

Dimensions in mm
 NOT Binding

a	b	c	d	d1	e	f	G	l	l1	l2	m	n	o	p1	p2	q	r	r1	s	t	u	v	w	x	y	z
457	498	269	82	-	480	448	G 3"	155	-	-	13	300	350	512	255	25	137	25	5	M8	310	443	481	183	-	16

INSTALLATION

- For proper operation of the machine, it must be provided with a suction FILTER and a vacuum/pressure limiting VALVE.
- Permissible ambient and fluid temperature in suction from -15 °C to +40 °C.
- Read the instruction manual carefully before installing the machine.