



# UPVC VALVES & FITTINGS

Technical Catalogue 2026-2027



UPVC FITTINGS & VALVES

# INDEX

## UPVC BALL VALVES

12



Ball Valve - Solvent Cement	14
Ball Valve - Solvent Cement x Female Threaded	14
Ball Valve - Female Threaded x Female Threaded	14
Ball Valve - Female Threaded Brass x Solvent Cement	15
Ball Valve - Female Threaded Brass x Female Threaded	15
Ball Valve - Female Threaded Brass x Female Threaded Brass	15
Ball Valve - Male Threaded Brass x Solvent Cement	16
Ball Valve - Male Threaded Brass x Female Threaded	16
Ball Valve - Male Threaded Brass x Female Threaded Brass	16
Single Union Ball Valve - Solvent Cement	17
Single Union Ball Valve - Solvent Cement x Female Threaded	17
Single Union Ball Valve - Female Threaded x Female Threaded	17
Single Union Ball Valve - Solvent Cement x Male Threaded	18
Single Union Ball Valve - Female Threaded x Male Threaded	18
Single Union Ball Valve - Flanged Connection	18
Ball Valve - Both Sides Flange Connection	19
Three Way Disc Valve	19
Two Way Disc Valve	19
Valve Box	20
Mini Valve PP - Female Threaded x Male Threaded	20
Mini Valve PP - Female Threaded x Female Threaded	20

## UPVC CHECK VALVE

21



Spring Check Valve - Solvent Cement	22
Spring Check Valve - Solvent Cement x Female Threaded	22
Spring Check Valve - Female Threaded x Female Threaded	22
Spring Transparent Check Valve - Solvent Cement	23
Spring Transparent Check Valve - Solvent Cement x Female Threaded	23
Spring Transparent Check Valve - Female Threaded x Female Threaded	23
Spring Check Valve - Flange Connection	24
Spring Transparent Check Valve - Flange Connection	24
Ball Check Valve - Solvent Cement	24
Wafer Check Valve	25
Swing Check Valve	25
Wafer Check Valve - Complete with Flange Set	26
Transparent Swing Check Valve - Solvent Cement	26

## UPVC BUTTERFLY VALVE

27



Butterfly Valve - without Flange Set	29
Butterfly Valve - Complete with Flange Set	29
Butterfly Valve with Gearbox - without Flange Set	30
Butterfly Valve with Gearbox - Complete with Flange Set	30

## UPVC ACTUATED BALL VALVES

31



Actuator Mountable Ball Valve - Solvent Cement	32
Actuator Mountable Ball Valve - Solvent Cement x Female Threaded	32
Actuator Mountable Ball Valve - Female Threaded x Female Threaded	32
Electric Actuated Ball Valve - Solvent Cement	33
Electric Actuated Ball Valve - Solvent Cement x Female Threaded	33
Electric Actuated Ball Valve - Female Threaded x Female Threaded	33
Pneumatic Actuated Ball Valve - Solvent Cement - Single Acting	34
Pneumatic Actuated Ball Valve - Solvent Cement x Female Thr. - Single Acting	34
Pneumatic Actuated Ball Valve - Female Thr. x Female Thr. - Single Acting	34
Pneumatic Actuated Ball Valve - Solvent Cement - Double Acting	35
Pneumatic Actuated Ball Valve - Solvent Cement x Female Thr. - Double Acting	35
Pneumatic Actuated Ball Valve - Female Thr. x Female Thr. - Double Acting	35
Actuator Mountable Ball Valve - Both Side Flanged	36
Electric Actuated Ball Valve - Both Side Flanged	36
Pneumatic Actuated Ball Valve - Both Side Flanged - Single Acting	36
Pneumatic Actuated Ball Valve - Both Side Flanged - Double Acting	36
Limit Switch Box	37
Namur Type Solenoid Valve	37
Pressure Control Valve	37
Clamp for Actuator Usage	37

## UPVC ACTUATED BUTTERFLY VALVES

38



Butterfly Valve for Actuator Usage - without Flange Set	39
Butterfly Valve for Actuator Usage - with Flange Set	39
Electric Actuated Butterfly Valve - without Flange Set	40
Electric Actuated Butterfly Valve - Complete Flange Set	40
Pneumatic Actuated Butterfly Valve - Single Acting - without Flange Set	41
Pneumatic Actuated Butterfly Valve - Single Acting - Complete with Flange Set	41
Pneumatic Actuated Butterfly Valve - Double Acting - without Flange Set	42
Pneumatic Actuated Butterfly Valve - Double Acting - Complete with Flange Set	42

# INDUSTRIAL VALVES

43



Industrial Ball Valve - Solvent Cement	44
Industrial Ball Valve - Solvent Cement x Female Threaded	44
Industrial Ball Valve - Female Threaded x Female Threaded	44
Actuator Mountable Industrial Ball Valve - Solvent Cement	45
Actuator Mountable Industrial Ball Valve - Solvent Cement x Female Threaded	45
Actuator Mountable Industrial Ball Valve - Female Threaded x Female Threaded	45
Electric Actuated Industrial Ball Valve - Solvent Cement	46
Electric Actuated Industrial Ball Valve - Solvent Cement x Female Threaded	46
Electric Actuated Industrial Ball Valve - Female Threaded x Female Threaded	46
Pneumatic Actuated Industrial Ball Valve - Solvent Cement - Single Acting	47
Pneumatic Actuated Industrial Ball Valve - S.Cement x Female Thr. - Single Acting	47
Pneumatic Actuated Industrial Ball Valve - Female Thr. x Female Thr. - Single Acting	47
Pneumatic Actuated Industrial Ball Valve - Solvent Cement - Double Acting	48
Pneumatic Actuated Industrial Ball Valve - S.Cement x Female Thr. - Double Acting	48
Pneumatic Actuated Industrial Ball Valve - Female Thr. x F. Thr. - Double Acting	48
Industrial Ball Valve for Acids - Both Side Flanged	49
Actuator Mountable Industrial Ball Valve - Both Side Flanged	49
Electric Actuated Industrial Ball Valve - Both Side Flanged	49
Pneumatic Actuated Industrial Ball Valve - Both Side Flanged - Single Acting	50
Pneumatic Actuated Industrial Ball Valve - Both Side Flanged - Double Acting	50
Industrial Butterfly Valve - without Flange Set	51
Industrial Butterfly Valve - Complete with Flange Set	51
Industrial Butterfly Valve for Actuator Usage - without Flange Set	52
Industrial Butterfly Valve for Actuator Usage - Complete with Flange Set	52
Electric Actuated Industrial Butterfly Valve - without Flange Set	53
Electric Actuated Industrial Butterfly Valve - Complete with Flange Set	53
Pneumatic Actuated Ind. Butterfly Valve - Single Acting - without Flange Set	54
Pneumatic Actuated Ind. Butterfly Valve - Single Acting - Complete with Flange Set	54
Pneumatic Actuated Ind. Butterfly Valve - Double Acting - without Flange Set	55
Pneumatic Actuated Ind. Butterfly Valve - Double Acting - Complete with Flange Set	55
Industrial Wafer Check Valve	56
Industrial Wafer Check Valve - Complete with Flange Set	56

# UPVC SOLVENT CEMENT FITTINGS EN 1452-3

57



Elbow 90°	58
Elbow 45°	58
Tee	59
Socket	59
Reducing Socket	60
Fixed Flange	60
Reducing Tee	61
Wall Conduit Flange	61
Cross	62
Cap	62
Conical Reduction	63
Vibration Flange	63
UPVC Flange Adaptor	64
UPVC Flange	64
UPVC Bling Flange	65

# UPVC UNIONS & THREADED PARTS

66



UPVC Union - Solvent Cement	67
UPVC Union - Solvent Cement x Female Threaded	68
UPVC Union - Female Threaded x Female Threaded	68
UPVC Male Union - Female Socket x Male Threaded	68
UPVC Female Union - Solvent Cement x Female Brass Threaded	69
UPVC Brass Male Union - Male Brass Threaded x Solvent Cement	69
UPVC Brass Female Union - Female Threaded x Solvent Cement	69
UPVC Male Union - Male Threaded x Solvent Cement	70
Threaded Fix Flange	70
Female Threaded Flange Adaptor	70
Male Threaded Adaptor	71
Reducing Male Threaded Adaptor	71
Female Threaded Adaptor	71
UPVC Hose Adaptor	72
Nippel	72
Female Threaded Cap	72
Male Threaded Cap	73
Union Sight Glass	73
Flanged Sight Glass	73

## UPVC PIPES & CLAMPS

74



UPVC Pipes - Solvent Socket PN 6/10/16	75
UPVC Pipes - Gasket Socket PN 6/10/16	76
EPDM Flat Gasket	77
UPVC Pipe Clamp	77
Repair Socket	77
Metal Pipe Clamp - Standard Triphone Clamp	78
Metal Pipe Clamp - Long Triphone Clamp	78
Metal Pipe Clamp - Nut Clamp	78
Metal Pipe Clamp - Nut Clamp/Heavy Duty	78

## UPVC SCH80 VALVES & FITTINGS

79



Ball Valve - Solvent Cement - ASTM	80
Ball Valve - Solvent Cement x Female Threaded - ASTM	80
Ball Valve - Female Threaded Brass x Solvent Cement - ASTM	80
Ball Valve - Male Threaded Brass x Solvent Cement - ASTM	80
Single Union Ball Valve - Solvent Cement - ASTM	81
Single Union Ball Valve - Solvent Cement x Female Threaded - ASTM	81
Single Union Ball Valve - Solvent Cement x Male Threaded - ASTM	81
Actuator Mountable Ball Valve - Solvent Cement - ASTM	81
Actuator Mountable Ball Valve - Solvent Cement x Female Threaded - ASTM	82
Electric Actuated Ball Valve - Solvent Cement - ASTM	82
Electric Actuated Ball Valve - Solvent Cement x Female Threaded - ASTM	82
Pneumatic Actuated Ball Ball Valve - Single Acting - Solvent Cement - ASTM	82
Pneumatic Actuated Ball Ball Valve - Single Acting - S.Cement x Female Thr. - ASTM	83
Pneumatic Actuated Ball Ball Valve - Double Acting - Solvent Cement - ASTM	83
Pneumatic Actuated Ball Ball Valve - Double Acting - S.Cement x Female Thr. - ASTM	83
Spring Check Valve - Solvent Cement - ASTM	84
Spring Check Valve - Solvent Cement x Female Threaded - ASTM	84
Spring Transparent Check Valve - Solvent Cement - ASTM	84
Spring Transparent Check Valve - Solvent Cement x Female Threaded - ASTM	84
Wafer Check Valve - ASTM	85
Wafer Check Valve - Complete with Flange Set - ASTM	85
Butterfly Valve - without Flange Set	85
Butterfly Valve - Complete with Flange Set	85
Elbow 90° - ASTM	86
Elbow 45° - ASTM	86
Tee - ASTM	86
Socket - ASTM	86
Conversion Socket - Metric / ASTM	87
Reducing Socket - ASTM	87
Cap - ASTM	87
UPVC Flange Adaptor - ASTM	87
UPVC Flange - ASTM	88
UPVC Union - Solvent Cement - ASTM	88
UPVC Union - Solvent Cement x Female Threaded- ASTM	88
UPVC Union - Solvent Cement x Female Brass Threaded - ASTM	88
UPVC Union - Male Brass Threaded x Solvent Cement - ASTM	89
Brass Union - Female Threaded x Solvent Cement - ASTM	89
Reducing Male Threaded Adaptor	89
Female Threaded Adaptor	89

## TECHNICAL MATERIALS

90



UPVC Solvent Cements - Plastic bottle with brush, medium duty formula	91
UPVC Pipe Cement	91
UPVC/ABS Cleaner	91
Pressure Gauge - 50 mm - 1/4bsp Connection	93
Pressure Gauge - 63 mm - 1/4bsp Connection	93
Pressure Gauge - 100 mm - 1/2bsp Connection	93
Mechanical Flowmeter - Solvent Cement	94
Mechanical Flowmeter - Flanged	94

## FILTRATION PRODUCTS

95



Pump Pre-Filters - Stainless Steel	96
Pump Pre-Filters - Plastic	96
Pump Pre-Filters - FR Polyester	96
Pump Pre-Filters - Fiberglass Reinforced Polyester	96
Turbidron - Bobin Wound Filter	97
Glass Filtration Media	99
Polymer Filtration Media	99
Silibeads	100
Fitvalf Streamer 2010	101
Fitvalf Pumpex 2010	102
Fitvalf Pumpex Jet	103

## CERTIFICATES

104



# Welcome to STAR WATER TECHNOLOGY & FITVALF

**STAR WATER TECHNOLOGY** is a recognized leader in the production of high-performance UPVC pipe fittings and valves. Our entry into the plastic injection moulding industry began in **2003**. By **2005**, with the critical support and expertise of our parent company, **GEMAŞ GENEL MÜHENDİSLİK AŞ**, we successfully launched the production of our signature **UPVC (Unplasticized Polyvinyl Chloride)** product line.



## Why UPVC? The STAR WATER TECHNOLOGY Advantage:

Our commitment to UPVC is driven by its exceptional characteristics, which perfectly meet the rigorous demands of high-pressure fluid transfer systems across various sectors:

- **Superior Quality and Strength:** UPVC offers high mechanical strength and robust quality, ensuring better long-term performance and reliability than many alternative plastics.
- **Specialized Expertise:** We operate within the specialized manufacturing niche of high-pressure UPVC fittings and valves, a focus that ensures deep expertise and consistent quality.
- **Critical Sector Integration:** Our components are essential across high-pressure water markets, including **agricultural irrigation, industrial water treatment, and general plumbing/construction.**

## FITVALF: Quality, Innovation, and Global Reach

Operating from our headquarters in Izmir, **STAR WATER TECHNOLOGY** proudly develops and manufactures products under our internationally registered brand, **FITVALF**.

**FITVALF** is synonymous with quality and pioneering design. We have demonstrated our commitment to excellence through innovative solutions, notably with our patented ball valves. Our entire production process is certified under the **ISO 9001 Quality Management System**, ensuring the highest possible standards for every component.

With an integrated facility spanning **4000 sqm** and a dedicated team of over **50 employees**, our brand continues to achieve increasing market share and recognition in both domestic and international markets.

### Strategic Market Focus Within the GEMAŞ Group

To ensure specialized focus and optimal service across all market segments, the GEMAŞ Group has structured its sales, marketing, and logistics operations into dedicated companies:

#### GEMAŞ PAZARLAMA LOJİSTİK AŞ: Swimming Pool Market Distribution



**GEMAŞ PAZARLAMA LOJİSTİK AŞ** is a focused sales, marketing, and logistics company within the Group. This entity is dedicated exclusively to the **global swimming pool markets** and acts as the **main distributor for FITVALF** products in this specialized sector.

#### FITVALF INDUSTRIAL WATER TECHNOLOGIES: Sales, Marketing, and Logistics

Established in **2024**, **FITVALF INDUSTRIAL WATER TECHNOLOGIES** is the new dedicated entity focusing on enhancing the commercial presence and logistical efficiency of the FITVALF brand across other high-pressure water markets.

This company manages the **sales, marketing and logistics operations** for all **FITVALF** branded products sold into:

- Agricultural Irrigation
- Industrial Water Treatment
- Construction and General Plumbing

This structure allows **STAR WATER TECHNOLOGY** to maintain an unwavering focus on **manufacturing excellence** and **product development**, while our specialized logistics companies ensure an **unparalleled customer experience and efficient global supply chain management**.

**TECHNICAL  
INFORMATION**

# Introduction to uPVC Water Handling Systems

Unplasticized Polyvinyl Chloride (uPVC) pipe systems are widely used in fluid handling applications thanks to their excellent combination of mechanical strength, chemical resistance, and durability. Unlike traditional metal piping, uPVC does not corrode, scale, or rust, making it ideal for long-term use in both industrial and domestic installations.

uPVC pipes and fittings offer:

- **High Chemical Resistance** – suitable for transporting acids, alkalis, salts, and a wide range of aggressive fluids.
- **Smooth Inner Surface** – minimizes pressure loss and prevents deposits, ensuring efficient flow.
- **Lightweight and Easy Installation** – reduces handling costs and enables quick assembly using solvent cement or mechanical connections.
- **Long Service Life** – resistant to UV radiation, weathering, and wear, ensuring reliability in diverse environments.
- **Safe and Hygienic** – approved for potable water supply and ideal for applications in irrigation, industrial processes, and water treatment.

Combined with valves and accessories, uPVC pipe systems provide a complete solution for fluid transport, delivering cost efficiency, safety, and durability across multiple sectors.

## Technical Characteristics

- **Material Properties:** Rigid, unplasticized PVC compound with high tensile and impact strength, excellent dimensional stability, and resistance to most inorganic chemicals.
- **Working Temperature Range:** 0 °C to +60 °C (intermittent peaks up to 65 °C depending on pressure and application).
- **Pressure Classes:** Typically available in pressure ratings PN 6, PN 10, PN 16 (according to ISO 1452 and DIN 8061/62 standards).
- **Standards & Approvals:**
  - **ISO 1452** – Plastic piping systems for water supply and buried/sewerage under pressure.
  - **DIN 8061 / 8062** – German standards for uPVC pipes and fittings.
  - **EN ISO 15493** – Industrial thermoplastic piping systems for fluids under pressure.
  - **ASTM D1785 / D2467** – American standards for PVC pipes and fittings.
  - **NSF / WRAS certifications** (depending on manufacturer) for potable water applications.
- **Joining Methods:** Primarily solvent cement welding and mechanical unions, ensuring leak-proof, easy-to-install connections.
- **Hydraulic Performance:** Smooth bore minimizes friction losses (low Hazen-Williams C-factor reduction over time) and prevents scaling or biological growth.
- **Service Life:** Over 50 years under normal operating conditions, with excellent resistance to UV, weathering, and soil conditions.

## Application Areas

- Potable water distribution and building installations
- Irrigation and agricultural systems
- Industrial chemical transport
- Water treatment and swimming pools
- Compressed air (non-oil applications)
- Wastewater and drainage systems

## Physical Properties of uPVC

Property	Value	Test Method
Density	1.38 - 1.45 g/cm <sup>3</sup>	ISO 1183
Tensile Strength	≥ 45 MPa	ISO 527
Elastic Modulus	~ 3000 MPa	ISO 527
Impact Strength (Charpy, unnotched)	≥ 10 kJ/m <sup>2</sup>	ISO 179
Vicat Softening Temperature	74 - 82 °C	ISO 306
Thermal Conductivity	0.16 W/m·K	DIN 52612
Linear Expansion Coefficient	0.07 mm/m·K	DIN 53752
Oxygen Index	45 - 50%	ISO 4589

## Pressure - Temperature Relationship

The maximum working pressure is 16 kg/cm<sup>2</sup> (232,06 PSI) from -20° C to + 25° C.

Above +25° C the working pressure decrease by linear way down to 4 kg/cm<sup>2</sup> (58,02 PSI) to +60°C.

### Pressure - Temperature relationship according to DIN 3441 BLATT 1

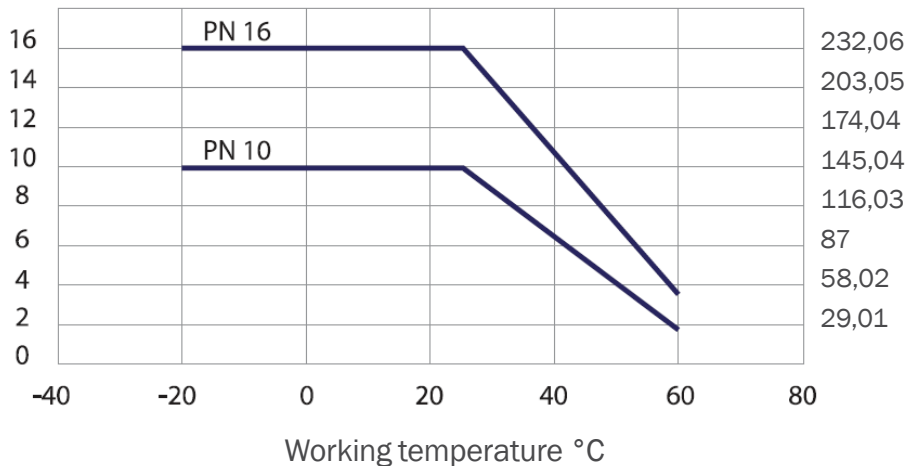

# Pipe Fitting Tolerances Solvent Cement

Fittings: ISO 727, DIN 8063 KIWA BRL-5 504, NF T54-028, UNI EN ISO 1452

Pipes: ISO 161, DIN 8062, KIWA 49, NFT54-016

D	DN	Mean outside diameter of fittings		Mean inside diameter of fittings	
		Min	Max	Min	Max
16	10	16	16,2	16,1	16,3
20	15	20	20,2	20,1	20,3
25	20	25	25,2	25,1	25,3
32	25	32	32,3	32,1	32,3
40	32	40	40,3	40,1	40,3
50	40	50	50,3	50,1	50,3
63	50	63	63,3	63,1	63,3
75	65	75	75,3	75,1	75,3
90	80	90	90,4	90,1	90,3
110	100	110	110,4	110,1	110,4
125	110	125	125,4	125,1	125,4
140	125	140	140,5	140,2	140,5
160	150	160	160,5	160,2	160,5
200	175	200	200,6	200,2	200,6
225	200	225	225,7	225,3	225,7
250	225	250	250,8	250,3	250,8
280	250	280	280,9	280,3	280,9
315	280	315	316	315,4	316

## Threading Dimensions

According to: ISO 7/1, BS 21, DIN 2999

G Nominal Diameter	Diameter of screw	Passo Pitch		Depth of thread	Length of thread assembling
		N° fil/1"	mm		
3/8"	16,66	19	1,337	0,856	11,04
1/2"	20,95	14	1,814	1,162	15
3/4"	26,44	14	1,814	1,162	16,3
1"	33,25	11	2,309	1,479	19,1
1¼"	41,91	11	2,309	1,479	21,4
1½"	47,8	11	2,309	1,479	21,4
2"	59,61	11	2,309	1,479	25,7
2¼"	65,71	11	2,309	1,479	-
2½"	75,18	11	2,309	1,479	30,2
2¾"	81,53	11	2,309	1,479	-
3"	87,88	11	2,309	1,479	33,3
4"	113,03	11	2,309	1,479	39,9
5"	138,43	11	2,309	1,479	43,6
6"	163,83	11	2,309	1,479	43,6

# Chemical Resistance

Three different classes of chemical resistance degree are conventionally used in this guide ie:

**Class 1: HIGH RESISTANCE (corrosion-proof)** - all materials belonging to this class are completely or almost completely corrosion-proof against the conveyed fluid, according to the specified operating conditions.

**Class 2: LIMITED RESISTANCE** - the materials belonging to this class are partially attacked by the conveyed chemical compound. The average life of the material is therefore shorter, and it is advisable to use a higher safety factor by selecting a higher SN rating pipe.

**Class 3: NO RESISTANCE** - all material belonging to this class are subject to corrosion by the conveyed fluid and they should therefore not be used.

The absence of any class indication means that no data are available concerning the chemical resistance of the material in respect of the conveyed fluid.

### ABBREVIATIONS

sat = saturated solution at 20°C, nd = undefined concentration,  
deb = weak concentration, comm = commercial solution. dil = diluted solution

	FORMULA	CONC %	TEMP (°C)	PVC	PE		FORMULA	CONC %	TEMP (°C)	PVC	PE
ACETALDEHYDE	CH <sub>3</sub> CHO	100	25 60	3 3	1	- FLUORIDE	NH <sub>4</sub> F	25	25 60	1 2	1 1
- AQUEOUS SOLUTION		40	25	3	1	- HYDROXIDE	NH <sub>4</sub> OH	28	25 60	- 2	1 1
ACETIC ACID	CH <sub>3</sub> COOH	≤ 25	25 60	1 2	1	- NITRATE	NH <sub>4</sub> NO <sub>3</sub>	sat	25 60	1 1	1 1
		30	25 60	1 2	1	- PHOSPHATE DIBASIC	NH <sub>4</sub> (HPO <sub>4</sub> ) <sub>2</sub>	all	25 60	1 1	1 1
		60	25 60	1 2	1	- PHOSPHAT META	(NH <sub>4</sub> ) <sub>4</sub> P <sub>4</sub> O <sub>12</sub>	all	25 60	1 1	
- GLACIAL		100	25 60	2 3	1 2	- PHOSPHATE TRI	(NH <sub>4</sub> ) <sub>2</sub> HPO <sub>4</sub>	all	25 60	1 1	
ACETIC ANHYDRIDE	(CH <sub>3</sub> CO) <sub>2</sub> O	100	25 60	3 3	2	- PERSULFATE	(NH <sub>4</sub> ) <sub>2</sub> S <sub>2</sub> O <sub>8</sub>	all	25 60	1 1	
ACETONE (DIMETHYL KETONE)	CH <sub>3</sub> COCH <sub>3</sub>	10	25 60	3 3	1	- SULFIDE	(NH <sub>4</sub> ) <sub>2</sub> S	deb	25 60	1 2	1 1
		100	25 60	3 3	2	- SULFHYDRATE	NH <sub>4</sub> OHSO <sub>4</sub>	dil sat	25 60 25 60	1 1 1 1	1 1 1 1
ACETOPHENONE (ACETYL BENZENE OR PHENYL METHYL KETONE)	CH <sub>3</sub> COC <sub>6</sub> H <sub>5</sub>	nd	25 60			AMYLACETATE (PENTYL ACETATE)	CH <sub>3</sub> CO <sub>2</sub> CH <sub>2</sub> (CH <sub>2</sub> ) <sub>3</sub> CH <sub>3</sub>	100	25 60	3 3	1 2
ACRYLONITRILE (ACRYLONITRILE OR VINYL CYANIDE)	CH <sub>2</sub> CHCN	technically pure	25 60	3	1	AMYLALCOHOL	CH <sub>3</sub> (CH <sub>2</sub> ) <sub>3</sub> CH <sub>2</sub> OH	nd	25 60	1 2	1 1
ADIPIC ACID AQUEOUS SOLUTION	(CH <sub>2</sub> CH <sub>2</sub> CO <sub>2</sub> H) <sub>2</sub>	sat.	25 60	1 2	1	ALNILINE (PHENYLAMINE OR AMINOBENZENE) - CHLORHYDRATE (ANILINE HYDROCHLORIDE)	C <sub>6</sub> H <sub>5</sub> HN <sub>2</sub> CH <sub>6</sub> H <sub>5</sub> NH <sub>2</sub> HCl	all nd	25 60	3 3	2 2
ALLYL ALCOHOL	CH <sub>2</sub> CHCH <sub>2</sub> OH	96	25 60	2 3	2	ANTIMONY - TRICHLORIDE	SbCl <sub>3</sub>	100	25 60	1 1	1 1
ALUM AQUEOUS SOLUTION (POTASH ALUM.SOL.)	Al <sub>2</sub> (SO <sub>4</sub> ) <sub>3</sub> K <sub>2</sub> SO <sub>4</sub> nH <sub>2</sub> O	dil dil sat.	25 60 60	1 2 2	1	ANTHRAQUINONE (SULFONIC ACID)	suspension	25	1 60	1 2	1 -
ALUMINIUM - CHLORIDE	AlCl <sub>3</sub>	all	25 60	1 1	1	AQUA REGIA	HCl+HNO <sub>3</sub>	100	25 60	2 2	3 3
- FLORIDE	AlF <sub>3</sub>	100	25 60	1 1	1	ARSENIC ACID	H <sub>3</sub> ASO <sub>4</sub>	deb	25 60	1 2	1 1
- HYDROXIDE	Al(OH) <sub>3</sub>	all	25 60	1 1	-		80	25 60	1 2	1 1	
NITRATE	Al(NO <sub>2</sub> ) <sub>3</sub>	nd	25 60	1 1	-	BARIUM CARBONATE - CHLORIDE	BACO <sub>3</sub> BaCl <sub>2</sub>	all 10	25 60	1 1	1 1
SULFATE	Al(SO <sub>4</sub> ) <sub>3</sub>	deb	25 60	1 1	1	- HYDROXIDE	Ba(OH) <sub>2</sub>	all	25 60	1 1	1 1
		sat	25 60	1 1	1	- SULFATE	BaSO <sub>4</sub>	nb	25 60	1 1	1 1
AMMONIA - AQUEOUS SOLUTION	NH <sub>3</sub>	deb	25 60	1 2	1	- SULFIDE	BaS	sat	25 60	1 1	
- DRY GAS		100	25 60	1 1	1	BEER		comm	25 60	1 1	1 1
- LIQUID		100	25 60	2 3	1	BENZALDEHYDE	C <sub>6</sub> H <sub>5</sub> CHO	nd	25 60	3 3	2 2
AMMONIUM - ACETATE	CH <sub>3</sub> COONH <sub>4</sub>	sat	25 60	- 2	1						
- CARBONATE	(NH <sub>4</sub> ) <sub>2</sub> CO <sub>3</sub>	all	25 60	1 2	1						

	FORMULA	CONC %	TEMP (°C)	PVC	PE		FORMULA	CONC %	TEMP (°C)	PVC	PE
DIOCTYLPHTHALATE		all	25 60	3 3	1 2	HYDROCHLORIC ACID (MURIATIC ACID)	HCl	≤25	25 60	1 2	1 1
DISTILLED WATER		100	25 60	1 1	1 1			≤ 37	25 60	1 1	1 2
DRINKING WATER		100	25 60	1 1	1 1	HYDROCYANIC ACID (PRUSSIC ACID OR HYDROGEN CYANIDE)	HCN	deb	25 60	1 1	1 1
ETHERS		all	25 60	3 3		HYDROFLUORIC ACID	HF	10	25 60	1 2	1 1
ETHYL - ACETATE (ACETIC ETHER)	CH <sub>3</sub> CO <sub>2</sub> C <sub>2</sub> H <sub>5</sub>	100	25 60	3 3	1 3	HYDROGEN	H <sub>2</sub>	all	25 60		
- ALCOHOL	CH <sub>3</sub> CH <sub>2</sub> OH	nd	25 60	1 2	1 2	HYDROGEN - PEROXIDE (BLEACH)	H <sub>2</sub> O <sub>2</sub>	30 50	25 60 25 60	1 1 1 2	1 1 - -
(ETHANOL) - CHLORIDE	CH <sub>3</sub> CH <sub>2</sub> Cl	all	25 60	3 3	2	- SULFIDE DRY		sat	25 60	1 2	1 1
- ETHER	CH <sub>3</sub> CH <sub>2</sub> OCH <sub>2</sub> CH <sub>3</sub>	all	25 60	3 3		- SULFIDE WET		sat	25 60	1 2	1 1
ETHYLENE - CHLOROHYDRIN - GLYCOL (ETHANEDIOL OR GLYCOL)	ClCH <sub>2</sub> CH <sub>2</sub> OH HOCH <sub>2</sub> CH <sub>2</sub> OH	100 comm	25 60 25 60	3 3 1 1	 1 3	HYDROSUPHITE		≤10	25 60	1 2	
FATTY ACIDS		nd	25 60	1 1		HYDROXYLAMINE SULPHATE	(H <sub>2</sub> NOH) <sub>2</sub> H <sub>2</sub> SO <sub>4</sub>	12	25 60	1 1	1 1
FERRIC - CHLORIDE	FeCl <sub>3</sub>	10	25 60	1 2		ILLUMINATING GAS		100	25 60	1 1	1 1
- NITRATE	Fe(NO <sub>3</sub> ) <sub>3</sub>	nd	25 60	1 1	1 1	IODINE - DRY AND WET - TINCTURE	I <sub>2</sub>	3 ≤3	25 60 25 60	2 3 2 3	
- DEXTRINE (BRITISH GUM OR STARCH GUM) - SULFATE	C <sub>6</sub> H <sub>12</sub> OCH <sub>2</sub> O Fe(SO <sub>4</sub> ) <sub>3</sub>	nd nd	25 60 25 60	1 2 1 1	1 1	ISOCTANE	C <sub>8</sub> H <sub>18</sub>	100	25 60	1 2	2
FERROUS - CHLORIDE - SULFATE	FeCl <sub>2</sub> FeSO <sub>4</sub>	sat nd	25 60 25 60	1 1 1 1	1 1	ISO-OCTANE	(CH <sub>3</sub> ) <sub>3</sub> CCH <sub>2</sub> (CH <sub>3</sub> ) <sub>2</sub>				
FERTILIZER		≤ 10 sat	25 60 25 60	1 1 1 1	1 1	ISOPROPYL -ETHER - ALCOHOL (ISOPROPANOL)	(CH <sub>3</sub> ) <sub>2</sub> CHOCH(CH <sub>3</sub> ) <sub>2</sub> (CH <sub>3</sub> ) <sub>2</sub> CHOH	100 100	25 60 25 60	2 3 2	2 3
FLUORINE GAS DRY	F <sub>2</sub>	100	25 60	2 3	2 3	LACTIC ACID	CH <sub>3</sub> COHCOOH	≤28	25 60	1 2	1 1
FLUROSILICIC ACID	H <sub>2</sub> SiF <sub>6</sub>	32	25 60	1 1	1 1	LANOLINE		nd	25 60	1 2	1 1
FORMALDEHYDE	HCOH	-	25 60	1 2	1 1	LEAD ACETATE	Pb(CH <sub>3</sub> COO) <sub>2</sub>	sat	25 60	1 1	1 -
FORMIC ACID	HCOOH	50 100	25 60 25 60	1 2 1 3	1 1 1 1	LINSEED OIL		comm	25 60	1 2	2 2
FRUIT PULP AND JUICE		comm	25 60	1 1	1 1	LUBRICATING OILS		comm	25 60	1 1	3
FUEL OIL		100 comm	25 60 25 60	1 1 1 2		MAGNESIUM - CARBONATE - CHLORIDE - HYDROXIDE -NITRATE - SULFATE	MgCO <sub>3</sub> MgCl <sub>2</sub> Mg(OH) <sub>2</sub> MgNO <sub>3</sub> MgSO <sub>4</sub>	all sat all nd dil sat	25 60 25 60 25 60 25 60	1 1 1 1 1 1 1 1	1 1 1 1 1 1 1 1
FURFUROLE ALCOHOL	C <sub>5</sub> H <sub>3</sub> OCH <sub>2</sub> OH	nd	25 60	3 3	2 2	MALEIC ACID	COOHCHCHCOOH	nd	25 60	1 1	1 1
GAS EXHAUST - ACID - WITH NITROUS - VAPOURS		all traces 60	25 60 25 60	1 1 1 1		MALIC ACID (HYDROXYSUCCINIC ACID)	CH <sub>2</sub> CHOH(COOH) <sub>2</sub>	nd	25 60	1 -	1 -
GAS PHOSGENE	ClCOCl	100	25 60	1 2	2 2	MERCURICHgCl <sub>2</sub> - CHLORIDE - CYANIDE	sat HgCN <sub>2</sub>	25 all	1 25 60	1 1 1	1 1 1
GELATINE		100	25 60	1 1	1 -	MERCUROUS NITRATE	HgNO <sub>3</sub>	nd	25 60	1 1	1 1
GLUCOSE (DEXTROSE)	C <sub>6</sub> H <sub>12</sub> O <sub>6</sub>	all	25 60	1 2	1 1	MERCURY	Hg	100	25 60	1 2	1 1
GLYCERINE AQ.SOL.(GLYCEROL)	HOCH <sub>2</sub> CHOHCH <sub>2</sub> OH	all	25 60	1 1	1 1	METHYL - ACETATE - ALCOHOL (METHANOL OR WOODSPIRIT) - BROMIDE (BROMOMETHANE) - CHORIDE (CHLOROMETHANE) - ETHYLKETONE	CH <sub>3</sub> COOCH <sub>3</sub> CH <sub>3</sub> OH CH <sub>3</sub> Br CH <sub>3</sub> Cl CH <sub>3</sub> COCH <sub>2</sub> CH <sub>3</sub>	100 nd 100 100 all	25 60 25 60 25 60 25 60	- - 1 3 3 3	- - 1 3 1 3 2
GLYCOGLUE AQUEOUS GLYCOLIC ACID		10 37	25 60 25 60	1 1 1 1	1 1	METHYLAMINE	CH <sub>3</sub> NH <sub>2</sub>	32	25 60	2 3	1 2
HEPTANE	C <sub>7</sub> H <sub>16</sub>	100	25 60	1 2	1 3						
HEXANE	C <sub>6</sub> H <sub>14</sub>	100	25 60	1 2	1 2						
HYDROBROMIC ACID	HBr	≤10 48	25 60 25 60	1 2 1 2	1 1 1 1						

	FORMULA	CONC %	TEMP (°C)	PVC	PE		FORMULA	CONC %	TEMP (°C)	PVC	PE
BENZENE (BENZOL)	C <sub>6</sub> H <sub>6</sub>	100	25 60	3 3	3	CHLORAMINE	NH <sub>2</sub> Cl	dil	25 60	1 1	1
- + LIGROIN		20/80	25 60	3 3		CHLORIC ACID	HClO <sub>3</sub>	20	25 60	1 2	1 3
- MONOCHLORINE	C <sub>6</sub> H <sub>3</sub> Cl	technically pure	25 60	3	2	CHLORINE	Cl <sub>2</sub>	sat	25 60	2 3	
BENZOIC ACID	C <sub>6</sub> H <sub>5</sub> COOH	sat	25 60	1 2	1 1	- DRY GAS		10 100	25 60 25 60	1 2 2 3	
BENZYL ALCOHOL	C <sub>6</sub> H <sub>5</sub> CH <sub>2</sub> OH	100	25 60	1 2		- WET GAS		5 g/m3 10 g/m3 66 g/m3	25 60 25 60	1 3 2 2	1 2
BORIC ACID (BORACIC ACID)	H <sub>3</sub> BO <sub>3</sub>	deb sat	25 60 25 60	1 2 1 2	1 1 1 1	- LIQUID		100	25 60	3	3
BRINE		comm	25 60	1 1		CHLOROACETIC ACID	ClCH <sub>2</sub> COH	85 100	25 60 25 60	1 2 3	2 3 3
BROMIC ACID	HBrO <sub>3</sub>	10	25 60	1 1	1 1	CHLOROBENZENE	C <sub>6</sub> H <sub>5</sub> Cl	all	25 60	3 3	
BROMINE	Br <sub>2</sub>	100	25 60	3 3	3	CHLOROFORM	CHCl <sub>3</sub>	all	25 60	3 3	2
- LIQUID						CHLOROSULPHONIC ACID	ClHSO <sub>3</sub>	100	25 60	2 3	3 3
- VAPOURS	low	25	2 60	3	3	CHROME ALUM	KCr(SO <sub>4</sub> ) <sub>2</sub>	nd	25 60	1 2	1 1
BUTADIENE	C <sub>4</sub> H <sub>6</sub>	100	25 60	1 1	3	CHROMIC ACID	CrO <sub>3</sub> +H <sub>2</sub> O	10 30 50	25 60 25 60	1 2 2	2 3 3
BUTANEDIOL AQUEOUS	CH <sub>3</sub> CH <sub>2</sub> CHOHCH <sub>2</sub> OH	10 concentrated	25 60 25 60	1 3 2 3		CHROMIC SOLUTION	CrO <sub>3</sub> +H <sub>2</sub> O+H <sub>2</sub> SO <sub>4</sub>	50/35/15	25 60	1 2	3 3
BUTANE GAS	C <sub>4</sub> H <sub>10</sub>	10	25 60	1 1	1	CITRIC ACID AQ.SOL.min.	C <sub>3</sub> H <sub>4</sub> (OH)(CO <sub>2</sub> H) <sub>3</sub>	50	25 60	1 1	1 1
BUTYL - ACETATE (BUTANATE)	CH <sub>3</sub> CO <sub>2</sub> CH <sub>2</sub> CH <sub>2</sub> CH <sub>2</sub> CH <sub>3</sub>	100	25 60	3 3	3	COPPER - CHLORIDE	CuCl <sub>2</sub>	sat	25 60	1 1	1 1
- ALCOHOL (BUTANOL)	C <sub>4</sub> H <sub>9</sub> OH		25 60	1 2	1	- CYANIDE	CuCN <sub>2</sub>	all	25 60	3 3	
- PHENOL	C <sub>4</sub> H <sub>9</sub> C <sub>6</sub> H <sub>4</sub> OH	100	25 60	2 2	3 3	- FLUORIDE	CuF <sub>2</sub>	all	25 60	1 1	1 1
BUTYLENE GLYCOL	C <sub>4</sub> H <sub>6</sub> (OH) <sub>2</sub>	100	25 60	2	1	- NITRATE	Cu(NO <sub>3</sub> ) <sub>2</sub>	nd	25 60	1 2	1 1
BUTYRIC ACID (BUTANOIC ACID)	C <sub>2</sub> H <sub>5</sub> CH <sub>2</sub> COOH	20 concentrated	25 60 25 60	1 2 3 3	1 1 3 3	- SULFATE	CuSO <sub>4</sub>	dil sat	25 60 25 60	1 1 1 1	1 1 1 1
CALCIUM - BISULFITE	Ca(HSO <sub>3</sub> ) <sub>2</sub>	nd	25 60	1 1	1 1	COTTONSEED OIL		comm	25 60	1 1	
- CARBONATE	CaCO <sub>3</sub>	all	25 60	1 1	1 1	CRESOL (HYDROXY TOLUENE)	CH <sub>3</sub> C <sub>6</sub> H <sub>4</sub> OH	≤90 ≥90	25 60 25 60	2 3 3 3	1
- CHLORATE	CaHCl	nd	25 60	1 1	1 1	CRESYLIC ACID	CH <sub>3</sub> CH <sub>6</sub> H <sub>4</sub> COOH	50	25 60	2 3	
- CHLORIDE	CaCl <sub>2</sub>	all	25 60	1 2	1 1	CYCLOHEXANE	C <sub>6</sub> H <sub>12</sub>	all	25 60	3 3	1
- HYDROXIDE	Ca(OH) <sub>2</sub>	all	25 60	1 1		CYCLOHEXANONE	C <sub>6</sub> H <sub>10</sub> O	all	25 60	3 3	1
- HYPOCHLORITE	Ca(OH)Cl	sat	25 60	2	1	DECAHYDRONAFTALENE	C <sub>10</sub> H <sub>18</sub>	nd	25 60	1 1	1 2
- NITRATE	Ca(NO <sub>3</sub> ) <sub>2</sub>	50	25 60	1 1	1	DEMINEALIZED WATER		100	25 60	1 1	1 1
- SULFATE	CaSO <sub>4</sub>	nd	25 60	1 1	1	DIBUTYPATHALATE	C <sub>6</sub> H <sub>4</sub> (CO <sub>2</sub> C <sub>4</sub> H <sub>9</sub> ) <sub>2</sub>	100	25 60	3 3	3
- SULFIDE	CaS	sat	25 60	1 1	2 2	DICHLORO-ACETIC ACID	Cl <sub>2</sub> CHCOOH	100	25 60	1 2	1 2
CAMPHOR OIL		nd	25 60	1 3	3	DICHLOROETHANE (ETHYLENE DICHLORIDE)	CH <sub>2</sub> ClCH <sub>2</sub> Cl	100	25 60	3 3	3 3
CARBON - DIOXIDE AQUEOUS SOLUTION	CO <sub>2</sub>	-	25 60	1 2	1	DICHLOROETHYLENE	Cl(CH <sub>2</sub> ) <sub>2</sub> Cl	100	25 60	3 3	3 3
- GAS		100	25 60	1 1	1	DIETHYL ETHER	C <sub>2</sub> H <sub>5</sub> OC <sub>2</sub> H <sub>5</sub>	100	25 60	3 3	3 3
- DISULFIDE	CS <sub>2</sub>	100	25 60	2 3	2	DIGLYCOLIC ACID	(CH <sub>2</sub> ) <sub>2</sub> O(CO <sub>2</sub> H) <sub>2</sub>	18	25 60	1 2	1 1
- MONOXIDE	CO	100	25 60	1 1	1	DIMETHYLAMINE	(CH <sub>3</sub> ) <sub>2</sub> NH	100	25 60	2 3	2 2
- TETRACHLORIDE	CCl <sub>4</sub>	100	25 60	2 3	3						
CARBONIC ACID - AQUEOUS SOLUTION	H <sub>2</sub> CO <sub>3</sub>	sat	25 60	1 1							
- DRY		100	25 60	1 1							
- WET		all	25 60	1 2							
CARBON OIL		comm	25 60	1 1							

	FORMULA	CONC %	TEMP (°C)	PVC	PE		FORMULA	CONC %	TEMP (°C)	PVC	PE
METHYLENE CHLORIDE (DICHLOROMETHANE)	CH <sub>2</sub> Cl <sub>2</sub>	100	25 60	3 3	3	- ANHYDRIDE		≤85 60	25 1	1 2	1
METHYL SULPHURIC ACID	CH <sub>3</sub> COOSO <sub>4</sub>	50 100	25 60 25 60	1 2 1 2	2 3			P <sub>2</sub> O <sub>5</sub>	nd	25 60	1 2
MILK		100	25 60	1 1	1	PHOSPHORUS TRICHLORIDE	PCl <sub>3</sub>	100	25 60	3 3	1
MINERAL ACIDULOUS WATER		nd	25 60	1 1	1	PHOTOGRAPHIC - DEVELOPER - EMULSION		comm	25 60	1 1	1
MOLASSES		comm	25 60	1 2	1 2	PHTHALIC ACID	C <sub>6</sub> H <sub>4</sub> (CO <sub>2</sub> H) <sub>2</sub>	50	25 60	- 3	1 1
NAPHTA		100	25 60	2 3	2 3	PICRIC ACID (2,4,6 TRINITROPENOL)	HOC <sub>6</sub> H <sub>2</sub> (NO <sub>2</sub> ) <sub>3</sub>	1	25 60	1 1	1 -
NAPHTALINE		100	25 60	1 2	1			≥1	25 60	3 3	1
NICKEL - CHLORIDE - NITRATE - SULFATE	NiCl <sub>3</sub> Ni(NO <sub>3</sub> ) <sub>2</sub> NiSO <sub>4</sub>	all nd dil sat	25 60 25 60 25 60	1 1 1 1 1 1	1 1 1 2 1 1	POTASSIUM - BICHROMATE (POTASSIUM HYDROGENCARBONATE) - BORATE - BROMATE	K <sub>2</sub> Cr <sub>2</sub> O <sub>7</sub> K <sub>3</sub> BO <sub>3</sub> KBrO <sub>3</sub>	40 sat nd	25 60 25 60	1 1 1	1 2 2
NITRIC ACID	HNO <sub>3</sub>	anhydrous 20 40 60 98	25 60 25 60 25 60	3 3 1 1 2 3 3 3	1 2 - 2 3 3	- BROMIDE KBr - CARBONATE (POTASH) - CHLORIDE (POTASSIUM MURIATE) - CHROMATE - CYANIDE	K <sub>2</sub> CO <sub>3</sub> KCl K <sub>2</sub> CrO <sub>4</sub> KCN	sat sat 40 sat	25 60 25 60 25 60	1 1 1 1 1 1	1 1 1 1 1 1
NITROBENZENE	C <sub>6</sub> H <sub>5</sub> NO <sub>2</sub>	all	25 60	3 3	2	- FERROCYANIDE - FLUORIDE - HYDROXIDE (CAUSTIC POTASH) - NITRATE KNO <sub>3</sub> (NITRE, SALTPETRE) - PERBORATE	K <sub>4</sub> Fe(CN) <sub>6</sub> H <sub>2</sub> O KF KOH sat KBO <sub>3</sub>	100 sat ≤60 25 all	25 60 25 60 25 60	1 1 1 2 1	1 1 1 1
OLEIC ACID	C <sub>8</sub> H <sub>17</sub> CHCH(CH <sub>2</sub> ) <sub>7</sub> CO <sub>2</sub> H	comm	25 60	1 1	- 2	- PERBORATE - PERMANGANATE (PERMANGANATE OF POTASH) - PERSULFATE - SULFATE	K <sub>2</sub> SO <sub>4</sub> KMnO <sub>4</sub> K <sub>2</sub> S <sub>2</sub> O <sub>8</sub> K <sub>2</sub> SO <sub>4</sub>	100 10 nd sat	25 60 25 60 25 60	1 1 1 2	1 1 1 1
OLEUM (FUMING SULPHURIC) ACID OR PYROSULPHURIC ACID - VAPOURS	H <sub>2</sub> S <sub>2</sub> O <sub>7</sub>	nd	25 60	3 3	3 3	PROPANE - GAS - LIQUID	C <sub>3</sub> H <sub>8</sub>	100 100	25 60 25 60	1 2	1 2
OLIVE OIL		comm	25 60	2 2	3	PROPYL ALCOHOL (PROPANOL)	C <sub>3</sub> H <sub>7</sub> OH	100	25 60	1 2	1 1
OXALIC ACID	HO <sub>2</sub> CCO <sub>2</sub> H	10 sat	25 60 25 60	1 2 1 1	1 1 1 1	PYRIDINE	CH(CH <sub>2</sub> ) <sub>2</sub> N	nd	25 60	3 3	1 2
OXYGEN	O <sub>2</sub>	all	25 60	1 1	1 2	RAIN WATER		100	25 60	1 1	1 1
OZONE	O <sub>3</sub>	nd	25 60	1 2	2 3	SEA WATER		100	25 60	1 1	1 1
PALMITIC ACID	CH <sub>3</sub> (CH <sub>2</sub> ) <sub>14</sub> COOH	10 70	25 60 25 60	1 1 1 1	- -	SILICIC ACID	H <sub>2</sub> SiO <sub>3</sub>	all	25 60	1 1	1 1
PARAFFIN (ALKANE) - EMULSION - OIL (KEROSENE)		nd comm nd	25 60 25 60	2 2 1 1	2 2	SILICONE OIL		nd	25 60	1 3	1 2
PERCHLORIC ACID	HClO <sub>4</sub>	100 70	25 60 25 60	1 2 1 2	1 1 1 2	SILVER - CYANIDE - NITRATE - PLATING SOLUTION	AgCN AgNO <sub>3</sub>	all nd	25 60 25 60	1 1 1 2	1 1 1 1
PETROL - REFINED - UNREFINED		100	25 60	1 1		SOAP - AQUEOUS SOLUTION - SODIC LYE		high ≤60	25 60	1 1	1 1
PHENOL - AQUEOUS SOLUTION (CARBOLIC ACID)	C <sub>6</sub> H <sub>5</sub> OH	1 ≤90	25 60 25 60	1 1 2 3	1 1	SODIUM - ACETATE	CH <sub>3</sub> COONa	100	25 60	1 1	1 1
PHENYL HYDRAZINE - CHLORHYDRATE	C <sub>6</sub> H <sub>5</sub> NHNH <sub>2</sub> C <sub>6</sub> H <sub>5</sub> NHNH <sub>3</sub> Cl	all sat	25 60 25 60	3 3 1 3	2 2 3 3						
PHOSPHORIC - ACID	H <sub>3</sub> PO <sub>4</sub>	≤25 ≤50	25 60 25 60	1 2 1 1	1 1 1 1						

	FORMULA	CONC %	TEMP (°C)	PVC	PE		FORMULA	CONC %	TEMP (°C)	PVC	PE
- BICARBONATE (SODIUM HYDROGEN CARBONATE)	NaHCO <sub>3</sub>	nd	25	1	1	- FUMING (OLEUM)		60	3	2	
		60	1	1	all			25	2		
- BISULFITE	NaHSO <sub>3</sub>	100	25	1	1	- NITRIC AQUEOUS SOLUTION	H <sub>2</sub> SO <sub>4</sub> +HNO <sub>3</sub> +H <sub>2</sub> O	48/49/3	25	1	3
			60	1	1				60	2	3
- BROMIDE	NaBr	sat	25	1				50/50/0	25	2	3
			60	1					60	3	3
- CARBONATE	Na <sub>2</sub> CO <sub>3</sub>	sat	25	1	1			10/20/70	25	1	2
			60	1	1				60	1	2
- CHLORATE	NaClO <sub>3</sub>	nd	25	1	1	TALLOW EMULSION		comm	25	1	1
			60	2	1		60	1	2		
- CHLORIDE	NaCl	dil	25	1	1	TANNIC ACID	C <sub>14</sub> H <sub>10</sub> O <sub>9</sub>	10	25	1	1
		60	2	1		60	1	1			
		sat	25	1	1	TARTARIC ACID	HOOC(CHOH) <sub>2</sub> COOH	all	25	1	1
		60	1	1		60	2	1			
- CYANIDE	NaCN	all	25	1		TETRACHLORO - ETHANE	CHCl <sub>2</sub> CHCl <sub>2</sub>	nd	25	3	2
- FERROCYANIDE	Na <sub>4</sub> Fe(CN) <sub>6</sub>	sat	25	1	1	- ETHYLENE (PERCHLOROETHYLENE)	CCl <sub>2</sub> CCl <sub>2</sub>	nd	25	3	2
			60	1	1				60	3	3
- FLUORIDE	NaF	all	25	1	1	TETRAETHYLLEAD	Pb(C <sub>2</sub> H <sub>5</sub> ) <sub>4</sub>	100	25	1	1
			60	1	1		60	2			
- HYDROXIDE	NaOH	60	25	1	1	TETRAHYDROFURAN	C <sub>4</sub> H <sub>8</sub> O	all	25	3	2
			60	1	1				60	3	3
- HYPOCHLORITE	NaOCl	deb	25	1	1	THIONYL CHLORIDE	SOCl <sub>2</sub>	-	25	3	3
			60	2					60		
- HYPOSULFITE	Na <sub>2</sub> S <sub>3</sub> O <sub>3</sub>	nd	25	1		THIOPHENE	C <sub>4</sub> H <sub>4</sub> S	100	25	3	2
			60	1					60	3	2
- NITRATE	NaNO <sub>3</sub>	nd	25	1	1	TOLUENE	C <sub>6</sub> H <sub>5</sub> CH <sub>3</sub>	100	25	3	2
			60	1	1		60	3	3		
- PERBORATE	NaBO <sub>3</sub> H <sub>2</sub> O	all	25	1		TRANSFORMER OIL		nd	25	1	1
			60	1					60	2	2
- PHOSPHATE di	Na <sub>2</sub> HPO <sub>4</sub>	all	25	1		TRICHLORO- ACETIC ACID	CCl <sub>3</sub> COOH	≤50	25	1	1
			60	1					60	3	2
- PHOSPHATE tri	Na <sub>3</sub> PO <sub>4</sub>	all	25	1	1	TRICHLOROETHYLENE	Cl <sub>2</sub> CCHCl	100	25	3	2
			60	1	1		60	3	2		
- SULPHATE	Na <sub>2</sub> SO <sub>4</sub>	dil	25	1		TRIETHANOLAMINE	N(CH <sub>2</sub> CH <sub>2</sub> OH) <sub>2</sub>	100	25	2	1
		60	1			60	3				
		sat	25	1	1	TURPENTINE		100	25	2	2
			60	1	1				60	2	3
- SULFIDE	Na <sub>2</sub> S	dil	25	1	1	UREA AQUEOUS SOLUTION	CO(NH <sub>2</sub> ) <sub>2</sub>	≤ 10	25	1	1
		60	2	1		33	25	1	1		
		sat	25	1	1			nd	25	1	1
			60	1	1	URINE			60	2	1
- SULFITE	NaSO <sub>3</sub>	sat	25	1		URIC ACID	C <sub>5</sub> H <sub>4</sub> N <sub>4</sub> O <sub>3</sub>	10	25	1	
			60	1					60	2	
STANNIC CHLORIDE	SnCl <sub>4</sub>	sat	25	1	1	VASELINE OIL		100	25	1	1
			60	1	1				60	3	2
STANNOUS CHLORIDE	SnCl <sub>2</sub>	dil	25	1	1	VINYL ACETATE	CH <sub>3</sub> CO <sub>2</sub> CHCH <sub>2</sub>	100	25	3	
			60	1	1				60	3	
STEARIC ACID	CH <sub>3</sub> (CH <sub>2</sub> ) <sub>16</sub> CO <sub>2</sub> H	100	25	1		WHISKEY		comm	25	1	
			60	1	2				60	1	
SUGAR SYRUP		high	25	1	1	WINES		comm	25	1	1
			60	2	1				60	1	
SULPHUR	S	100	25	1		WINE VINEGAR		comm	25	1	1
			60	2					60	2	1
- DIOXIDE AQUEOUS	SO <sub>2</sub>	sat	25	1	1	ZINC - CHLORIDE	ZnCl <sub>2</sub>	dil	25	1	1
			60	2			sat	25	1	1	
			60	1	1			60	1	1	
- DIOXIDE DRY		all	25	1	1				25	1	1
			60	1	1				60		
- DIOXIDE LIQUID		100	25	2	1	- CHROMATE	ZnCrO <sub>4</sub>	all	25	1	
			60	3	2				60	1	
- TRIOXIDE	SO <sub>3</sub>	100	25	2	3	- CYANIDE	Zn(CN) <sub>2</sub>	all	25	1	
			60	2	3			60			
SULPHURIC ACID	H <sub>2</sub> SO <sub>4</sub>	≤ 10	25	1	1	- NITRATE	Zn(NO <sub>3</sub> ) <sub>2</sub>	nd	25	1	
		60	1	1			60	1			
		≤75	25	1	1	- SULFATE	ZnSO <sub>4</sub>	dil	25	1	1
		60	2	2			sat	25	1	1	
		≤90	25	1	2			60	1	1	
	60	2	2				60	1	1		
	≤96	25	2	2				60	1	1	



# UPVC BALL VALVES

# Ball Valves

- Adjustable ball pressure as well as patented union screwing with handle.
- Low torque handle
- Seats from HDPE based polymer that increases lubricity.
- EPDM o-rings.
- PN16.



**1.** Pull out the Handle

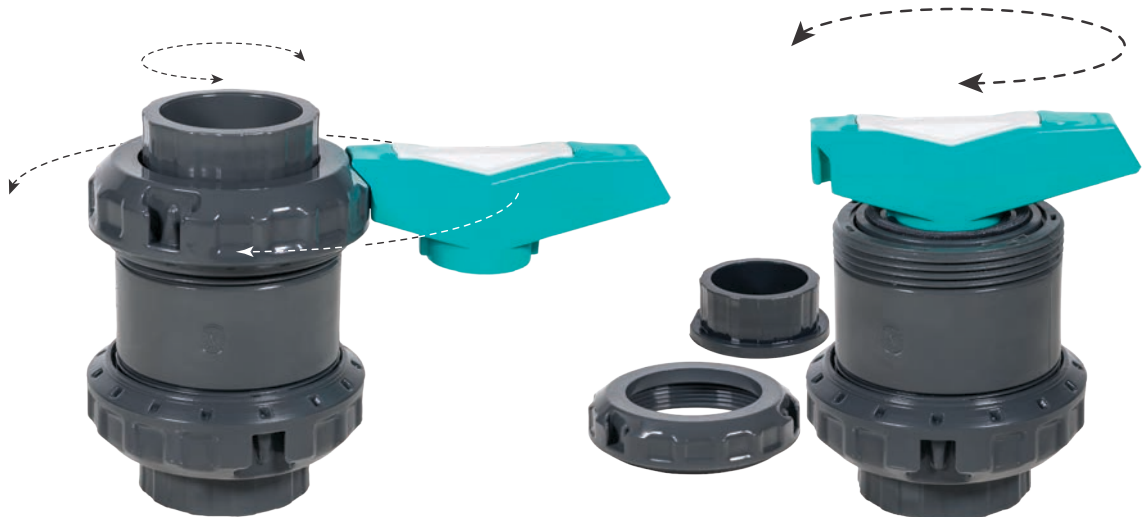

**2.** Place the Handle to Slot and turn the Union by Handle.

**3.** Take out the Union and the Pipe Connection, then place the Handle and turn to adjust ball pressure.



Body made of UPVC.  
 Handle made of ABS.  
 Separate name plate OEM efficiency.  
 HDPE seats. O-rings EPDM.  
 Patented union-screwing by means of handle.

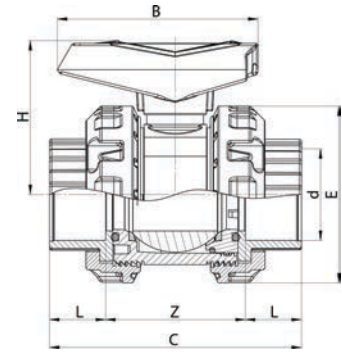

**Ball Valve**  
 Solvent Cement

d	DN	Code	B	H	E	L	Z	C	PN	Box
20	16	131111L	80	59	64,5	20	53	93	16	35
25	20	131112L	80	59	64,5	20	53	93	16	35
32	25	131113L	92	66	75	23,5	60	107	16	20
40	32	131114L	103	78	88	26	70	122	16	12
50	40	131115L	116	95	100	33	80	146	16	12
63	50	131116L	137	106	122	38	93	169	16	6
75	65	131117L	161	113	143	44	109	197	16	2
90	80	131118L	161	113	143	52	114	221	16	2
110	100	131119L	248	171	226	60	166	286	16	1



Body made of UPVC.  
 Handle made of ABS.  
 Separate name plate OEM efficiency.  
 HDPE seats. O-rings EPDM.  
 Patented union-screwing by means of handle.  
 One side BSP threaded.

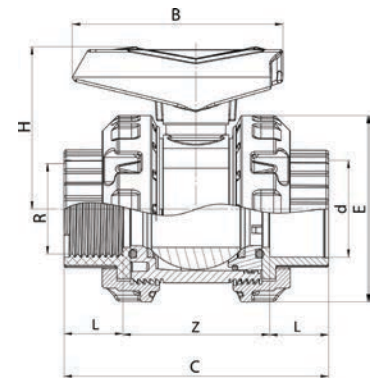

**Ball Valve**  
 Solvent Cement x Female Threaded

d	R	DN	Code	B	H	E	L	Z	C	PN	Box
20	1/2"	16	131111LT1	80	59	64,5	20	53	93	16	35
25	3/4"	20	131112LT1	80	59	64,5	20	53	93	16	35
32	1"	25	131113LT1	92	66	75	23,5	60	107	16	20
40	1 1/4"	32	131114LT1	103	78	88	26	70	122	16	12
50	1 1/2"	40	131115LT1	116	95	100	33	80	146	16	12
63	2"	50	131116LT1	137	106	122	38	93	169	16	6
75	2 1/2"	65	131117LT1	161	113	143	44	109	197	16	2
90	3"	80	131118LT1	161	113	143	52	114	221	16	2
110	4"	100	131119LT1	248	171	226	60	166	286	16	1



Body made of UPVC.  
 Handle made of ABS.  
 Separate name plate OEM efficiency.  
 HDPE seats. O-rings EPDM.  
 Patented union-screwing by means of handle.  
 Two sides BSP threaded.

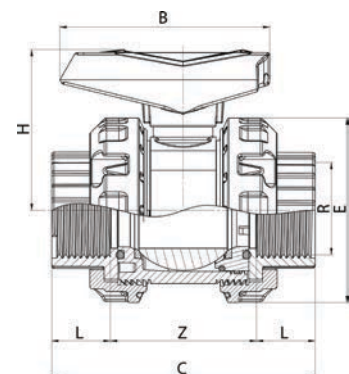

**Ball Valve**  
 Female Threaded x Female Threaded

R	DN	Code	B	H	E	L	Z	C	PN	Box
1/2"	16	131111LT	80	59	64,5	20	53	93	16	35
3/4"	20	131112LT	80	59	64,5	20	53	93	16	35
1"	25	131113LT	92	66	75	23,5	60	107	16	20
1 1/4"	32	131114LT	103	78	88	26	70	122	16	12
1 1/2"	40	131115LT	116	95	100	33	80	146	16	12
2"	50	131116LT	137	106	122	38	93	169	16	6
2 1/2"	65	131117LT	161	113	143	44	109	197	16	2
3"	80	131118LT	161	113	143	52	114	221	16	2
4"	100	131119LT	248	171	226	60	166	286	16	1



One side BSP female threaded made of high grade brass.  
Other side solvent cement.  
Suitable for transition to pumps, filters or any kind of metallic equipment.

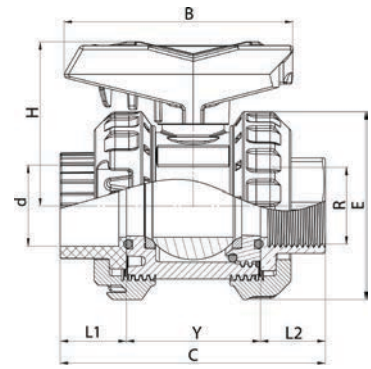

**Ball Valve**  
Female Threaded Brass x Solvent Cement

d	R	DN	Code	B	H	E	L1	L2	Y	C	PN	Box
20	1/2"	16	131111LB	80	59	64,5	23	24	47	94	16	35
25	3/4"	20	131112LB	80	59	64,5	23	24	47	94	16	35
32	1"	25	131113LB	92	66	75	27	28	53	108	16	20
40	1 1/4"	32	131114LB	103	78	88	30	31	62	123	16	12
50	1 1/2"	40	131115LB	116	95	100	38	39	70	147	16	12
63	2"	50	131116LB	137	106	122	42,5	43,5	84	170	16	6



One side BSP female threaded made of high grade brass.  
Other side UPVC BSP female threaded.  
Suitable for transition to pumps, filters or any kind of metallic equipment.

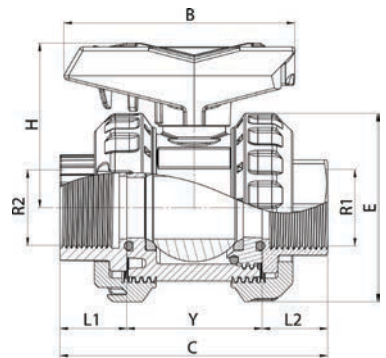

**Ball Valve**  
Female Threaded Brass x Female Threaded

R1	R2	DN	Code	B	H	E	L1	L2	Y	C	PN	Box
1/2"	1/2"	16	131111LB1	80	59	64,5	23	24	47	94	16	35
3/4"	3/4"	20	131112LB1	80	59	64,5	23	24	47	94	16	35
1"	1"	25	131113LB1	92	66	75	27	28	53	108	16	20
1 1/4"	1 1/4"	32	131114LB1	103	78	88	30	31	62	123	16	12
1 1/2"	1 1/2"	40	131115LB1	116	95	100	38	39	70	147	16	12
2"	2"	50	131116LB1	137	106	122	42,5	43,5	84	170	16	6



Two sides female threaded made of high grade brass.  
Two sides BSP female threaded.  
Suitable for use UPVC valve on metallic equipments or pipeline.

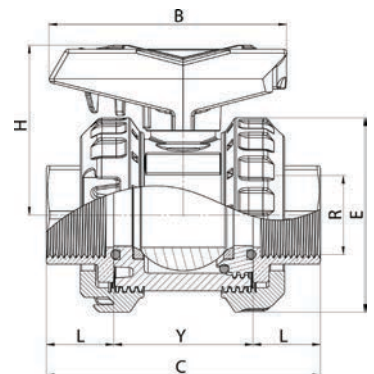

**Ball Valve**  
Female Threaded Brass x Female Threaded Brass

R	DN	Code	B	H	E	L	Y	C	PN	Box
1/2"	16	131111LB2	80	59	64,5	24,5	47	96	16	35
3/4"	20	131112LB2	80	59	64,5	24,5	47	96	16	35
1"	25	131113LB2	92	66	75	25	53	102	16	20
1 1/4"	32	131114LB2	103	78	88	27	62	116	16	12
1 1/2"	40	131115LB2	116	95	100	35	70	140	16	12
2"	50	131116LB2	137	106	122	40	84	164	16	6



**NEW PRODUCT**

One side BSP male threaded made of high grade brass.  
Other side solvent cement.  
Suitable for transition to pumps, filters or any kind of metallic equipment.

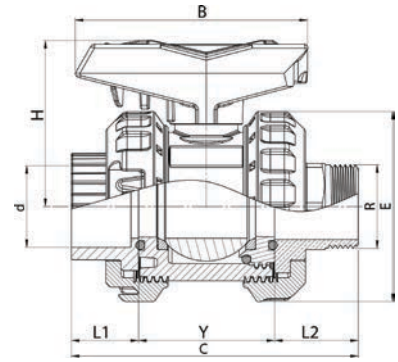

## Ball Valve Male Threaded Brass x Solvent Cement

d	R	DN	Code	B	H	E	L1	L2	Y	C	PN	Box
20	1/2"	16	131111LB3	80	59	64,5	23	49	47	119	16	35
25	3/4"	20	131112LB3	80	59	64,5	23	40	47	110	16	35
32	1"	25	131113LB3	92	66	75	27	56	53	136	16	20
40	1 1/4"	32	131114LB3	103	78	88	30	60	62	152	16	12
50	1 1/2"	40	131115LB3	116	95	100	38	57	70	165	16	12
63	2"	50	131116LB3	137	106	122	42,5	73,5	84	200	16	6



**NEW PRODUCT**

One side BSP male threaded made of high grade brass.  
Other side UPVC BSP female threads.  
Suitable for transition to pumps, filters or any kind of metallic equipment.

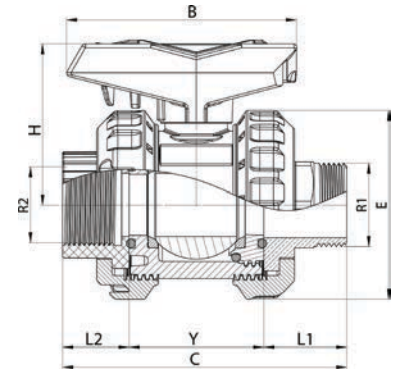

## Ball Valve Male Threaded Brass x Female Threaded

R1	R2	DN	Code	B	H	E	L1	L2	Y	C	PN	Box
1/2"	1/2"	16	131111LB4	80	59	64,5	23	49	47	119	16	35
3/4"	3/4"	20	131112LB4	80	59	64,5	23	40	47	110	16	35
1"	1"	25	131113LB4	92	66	75	27	56	53	136	16	20
1 1/4"	1 1/4"	32	131114LB4	103	78	88	30	60	62	152	16	12
1 1/2"	1 1/2"	40	131115LB4	116	95	100	38	57	70	165	16	12
2"	2"	50	131116LB4	137	106	122	42,5	73,5	84	200	16	6



**NEW PRODUCT**

One side female, other side male BSP threaded made of high grade brass.  
Suitable for use UPVC valve on metallic equipments or pipeline.

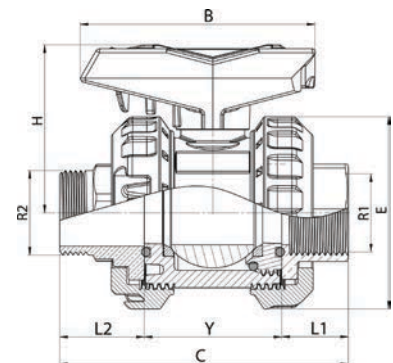

## Ball Valve Male Threaded Brass x Female Threaded Brass

R1	R2	DN	Code	B	H	E	L1	L2	Y	C	PN	Box
1/2"	1/2"	16	131111LB5	80	59	64,5	24	49	47	120	16	35
3/4"	3/4"	20	131112LB5	80	59	64,5	24	40	47	111	16	35
1"	1"	25	131113LB5	92	66	75	28	56	53	137	16	20
1 1/4"	1 1/4"	32	131114LB5	103	78	88	31	60	62	153	16	12
1 1/2"	1 1/2"	40	131115LB5	116	95	100	38	57	70	166	16	12
2"	2"	50	131116LB5	137	106	122	43,5	73,5	84	201	16	6



Body made of UPVC. Handle made of ABS.  
 Separate name plate for OEM efficiency.  
 Seats from HDPE, O-rings EPDM.  
 Adjustable ball pressure.  
 Patented union-screwing by means of handle.

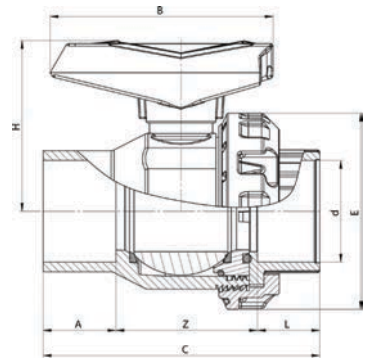

## Single Union Ball Valve

Solvent Cement

d	DN	Code	B	H	E	L	A	Z	C	PN	Box
25	20	131412	80	59	64,5	20	18	50	88	16	35
32	25	131413	92	66	75	23,5	22,5	56,5	103	16	20
40	32	131414	103	78	88	26	26	70	122	16	12
50	40	131415	116	95	100	33	38	72	143	16	12
63	50	131416	137	106	122	38	43	90	171	16	6
75	65	131417	161	113	143	44	47	101	192	16	2
90	80	131418	161	113	143	52	47	101	200	16	2



Body made of UPVC. Handle made of ABS.  
 Separate name plate for OEM efficiency.  
 Seats from HDPE, O-rings EPDM.  
 Adjustable ball pressure.  
 Patented union-screwing by means of handle.  
 Fixed side BSP female threaded.

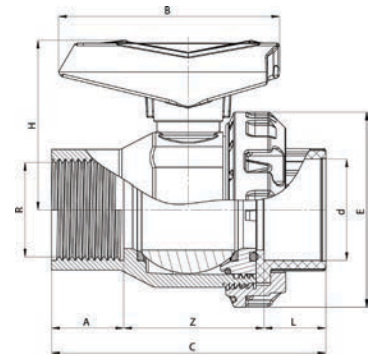

## Single Union Ball Valve

Solvent Cement x Female Threaded

d	R	DN	Code	B	H	E	L	A	Z	C	PN	Box
25	3/4"	20	131412T1	80	59	64,5	20	18	50	88	16	35
32	1"	25	131413T1	92	66	75	23,5	22,5	56,5	103	16	20
40	1 1/4"	32	131414T1	103	78	88	26	26	70	122	16	12
50	1 1/2"	40	131415T1	116	95	100	33	38	72	143	16	12
63	2"	50	131416T1	137	106	122	38	43	92	171	16	6
75	2 1/2"	65	131417T1	161	113	143	44	47	101	192	16	2
90	3"	80	131418T1	161	113	143	52	47	101	200	16	2



Body made of UPVC. Handle made of ABS.  
 Separate name plate for OEM efficiency.  
 Seats from HDPE, O-rings EPDM.  
 Adjustable ball pressure.  
 Patented union-screwing by means of handle.  
 Both sides BSP female threaded.

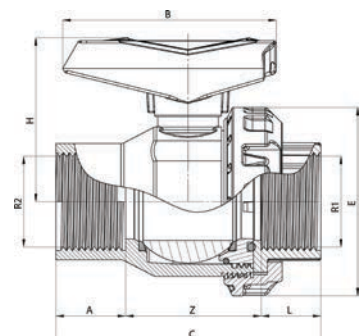

## Single Union Ball Valve

Female Threaded x Female Threaded

R1	R2	DN	Code	B	H	E	L	A	Z	C	PN	Box
3/4"	3/4"	20	131412T	80	59	64,5	20	18	50	88	16	35
1"	1"	25	131413T	92	66	75	23,5	22,5	56,5	103	16	20
1 1/4"	1 1/4"	32	131414T	103	78	88	26	26	70	122	16	12
1 1/2"	1 1/2"	40	131415T	116	95	100	33	38	72	143	16	12
2"	2"	50	131416T	137	106	122	38	43	90	171	16	6
2 1/2"	2 1/2"	65	131417T	161	113	143	44	47	101	192	16	2
3"	3"	80	131418T	161	113	143	52	47	101	200	16	2



Body made of UPVC. Handle made of ABS.  
 Separate name plate for OEM efficiency.  
 Seats from HDPE, O-rings EPDM.  
 Adjustable ball pressure.  
 Patented union-screwing by means of handle.  
 Fixed side BSP male threaded.

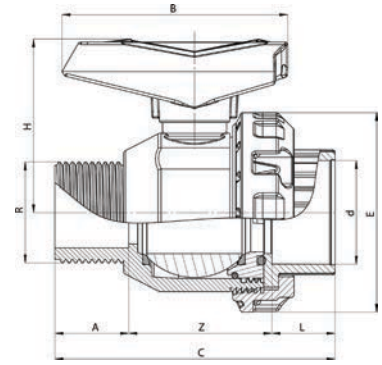

## Single Union Ball Valve

### Solvent Cement x Male Threaded

d	R	DN	Code	B	H	E	L	A	Z	C	PN	Box
25	3/4"	20	131412T2	80	59	64,5	20	18	50	88	16	35
32	1"	25	131413T2	92	66	75	23,5	22,5	56,5	103	16	20
40	1 1/4"	32	131414T2	103	78	88	26	26	70	122	16	12
50	1 1/2"	40	131415T2	116	95	100	33	38	72	143	16	12
63	2"	50	131416T2	137	106	122	38	43	90	171	16	6
75	2 1/2"	65	131417T2	161	113	143	44	47	101	192	16	2
90	3"	80	131418T2	161	113	143	52	47	101	200	16	2



Body made of UPVC. Handle made of ABS.  
 Separate name plate for OEM efficiency.  
 Seats from HDPE, O-rings EPDM.  
 Adjustable ball pressure.  
 Patented union-screwing by means of handle.  
 Fixed side BSP male threaded, union side BSP female threaded.

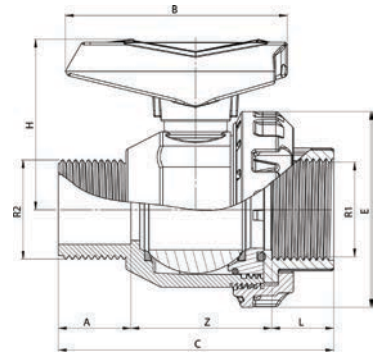

## Single Union Ball Valve

### Female Threaded x Male Threaded

R1	R2	DN	Code	B	H	E	L	A	Z	C	PN	Box
3/4"	3/4"	20	131412T3	80	59	64,5	20	18	50	88	16	35
1"	1"	25	131413T3	92	66	75	23,5	22,5	56,5	103	16	20
1 1/4"	1 1/4"	32	131414T3	103	78	88	26	26	70	122	16	12
1 1/2"	1 1/2"	40	131415T3	116	95	100	33	38	72	143	16	12
2"	2"	50	131416T3	137	106	122	38	43	90	171	16	6
2 1/2"	2 1/2"	65	131417T3	161	113	143	44	47	101	192	16	2
3"	3"	80	131418T3	161	113	143	52	47	101	200	16	2



Body made of UPVC. Handle made of ABS.  
 Separate name plate for OEM efficiency.  
 Seats from HDPE, O-rings EPDM.  
 Adjustable ball pressure.  
 Patented union-screwing by means of handle.  
 Connections with loose flange DIN8063.

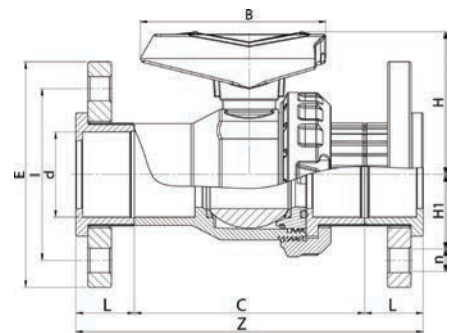

## Single Union Ball Valve

### Flange Connection

d	DN	inch	Code	B	H	E	I	L	Z	C	H1	n	PN	Box
50	40	1 1/2"	131415F	116	95	150	110	38,5	222	146	46	18	16	2
63	50	2"	131416F	137	106	167	127	42,5	254	169	54,5	18	16	1
75	65	2 1/2"	131417F	161	113	186	145	47	291	197	63,5	18	16	1
90	80	3"	131418F	161	113	202	163	58	337	221	72	19,5	16	1



Body made of UPVC. Handle made of ABS.  
 Separate name plate OEM efficiency.  
 HDPE seats. O-rings EPDM.  
 Patented union-screwing by means of handle.  
 Connections with loose flange DIN8063.

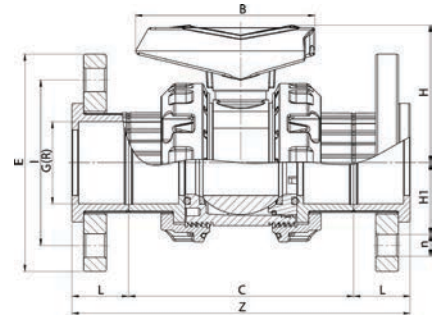

**Ball Valve**  
 Both Sides Flange Connection

G	DN	inch	Code	B	H	E	I	L	Z	C	H1	n	PN	Box
50	40	1½"	131115F	116	95	151	110	38	222	146	46	18	16	2
63	50	2"	131116F	137	106	167	127	42,5	254	169	54,5	18	16	1
75	65	2½"	131117F	161	113	186	145	47	291	197	63,5	18	16	1
90	80	3"	131118F	161	113	202	163	58	337	221	72	19,5	16	1
110	100	4"	131119F	248	171	222	182	65	416	286	82	17,5	16	1



Body made of UPVC.  
 Disc made of GFPP.  
 L disc structure.  
 Suitable to divert water for suction lines, bypass lines in swimming pool applications.

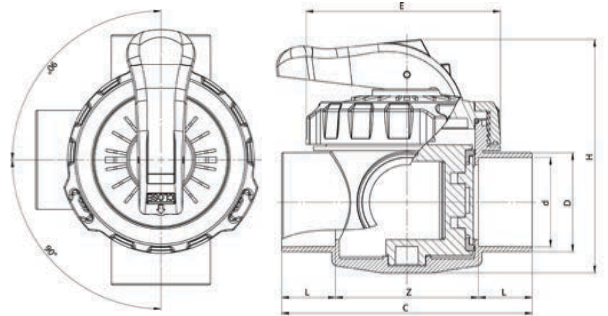

**Three Way Disc Valve**

mm	DN	Code	C	d	D	E	L	Z	H	PN	Box
63	50	131172G	177	63	70	142	38	101	165	10	3



Body made of UPVC.  
 Disc made of GFPP.  
 Suitable to be used as an alternative for UPVC ball valve.  
 Low pressure loss compared some size of ball valve.

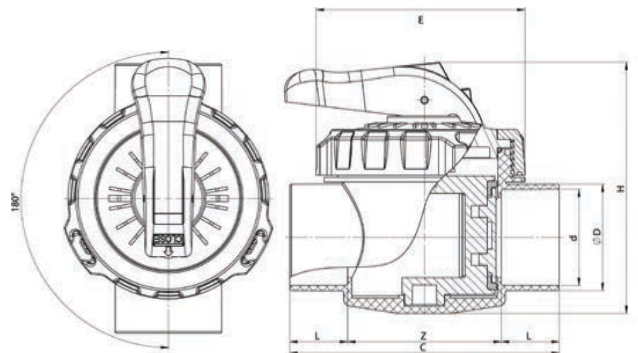

**Two Way Disc Valve**

mm	DN	Code	C	d	D	E	L	Z	H	PN	Box
63	50	131173G	177	63	70	142	38	101	165	10	6



Body and lid made of high grade GFPP.

## Valve Box

inch	Code	D	d	L	Z	H1
10"	135601	240	320	-	-	255
12"	135602	375	255	500	400	305

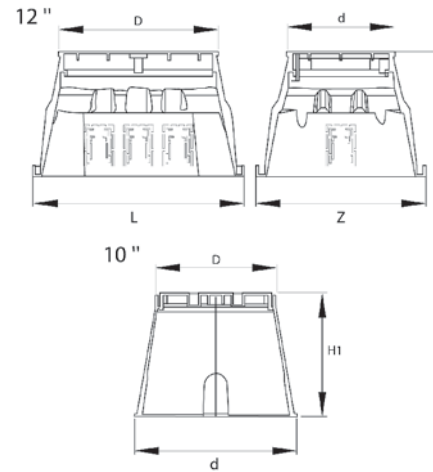

Body made of high grade GFPP.  
Handle made of ABS.  
High chemical, UV and temperature resistance compared to UPVC.

## Mini Valve PP Female Threaded - Male Threaded

D	Code	B	H	G	E	L	Z	PN	Box
3/4"	131211	76	63	25	65	21	44	16	100
1"	131212	76	63	31	65	21	44	16	100

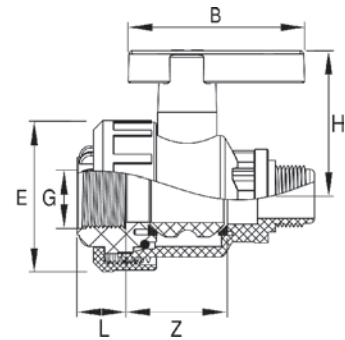

Body made of high grade GFPP.  
Handle made of ABS.  
High chemical, UV and temperature resistance compared to UPVC.

## Mini Valve PP Female Threaded - Female Threaded

D	Code	B	H	G	E	L	Z	PN	Box
3/4"	131211D	76	63	50	65	21	44	16	100
1"	131212D	76	63	63	65	21	44	16	100

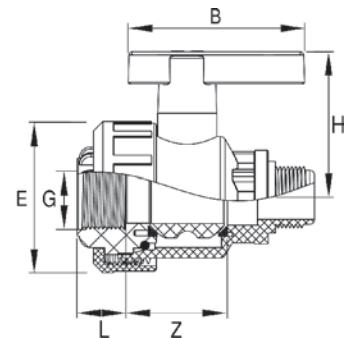



# UPVC CHECK VALVES



Body made of UPVC.  
 Spring made of stainless steel.  
 Unions are designed to be unscrewed with patented fitvalf ball valve handle.  
 Horizontal or vertical installation.

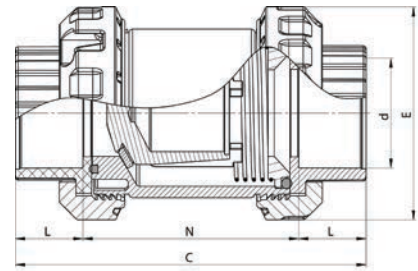

## Spring Check Valve

Solvent Cement

d	DN	Code	L	N	C	E	PN	Box
50	40	131315	33	106	172	100	16	6
63	50	131316	38	123	199	122	16	6
75	65	131317	44	144	232	148	16	2
90	80	131318	52	149	253	148	16	2



Body made of UPVC.  
 Spring made of stainless steel.  
 Unions are designed to be unscrewed with patented fitvalf ball valve handle.  
 Horizontal or vertical installation.  
 One side BSP female threaded.

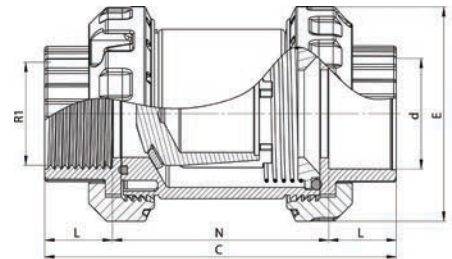

## Spring Check Valve

Solvent Cement x Female Threaded

d	R1	DN	Code	L	N	C	E	PN	Box
50	1½"	40	131315T1	33	106	172	100	16	6
63	2"	50	131316T1	38	123	199	122	16	6
75	2½"	65	131317T1	44	144	232	148	16	2
90	3"	80	131318T1	52	149	253	148	16	2



Body made of UPVC.  
 Spring made of stainless steel.  
 Unions are designed to be unscrewed with patented fitvalf ball valve handle.  
 Horizontal or vertical installation.  
 Two side BSP female threaded.

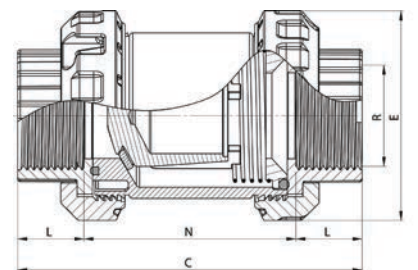

## Spring Check Valve

Female Threaded x Female Threaded

R	DN	Code	L	N	C	E	PN	Box
1½"	40	131315T	33	106	172	100	16	6
2"	50	131316T	38	123	199	122	16	6
2½"	65	131317T	44	144	232	148	16	2
3"	80	131318T	52	149	253	148	16	2



Body made of polycarbonate.  
Transparent view.  
Spring made of Stainless Steel.  
Horizontal or vertical installation.

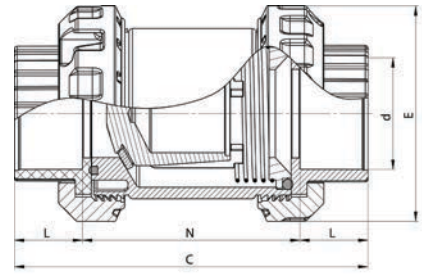

**Spring Transparent Check Valve**  
Solvent Cement

d	DN	Code	L	N	C	E	PN	Box
50	40	131315PC	33	106	172	100	16	6
63	50	131316PC	38	123	199	122	16	6
75	65	131317PC	44	144	232	148	16	2
90	80	131318PC	52	149	253	148	16	2



Body made of polycarbonate.  
Transparent view.  
Spring made of Stainless Steel.  
Horizontal or vertical installation.  
One side BSP female threaded.

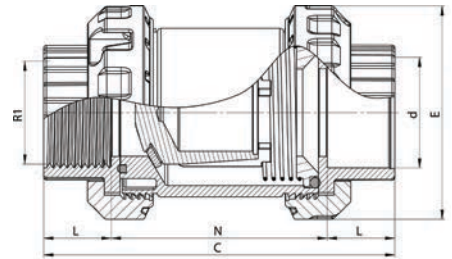

**Spring Transparent Check Valve**  
Solvent Cement x Female Threaded

d	R1	DN	Code	L	N	C	E	PN	Box
50	1½"	40	131315PCT1	33	106	172	100	16	6
63	2"	50	131316PCT1	38	123	199	122	16	6
75	2½"	65	131317PCT1	44	144	232	148	16	2
90	3"	80	131318PCT1	52	149	253	148	16	2



Body made of polycarbonate.  
Transparent view.  
Spring made of Stainless Steel.  
Horizontal or vertical installation.  
Two sides BSP female threaded.

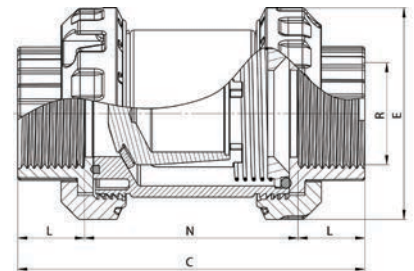

**Spring Transparent Check Valve**  
Female Threaded x Female Threaded

R	DN	Code	L	N	C	E	PN	Box
1½"	40	131315PCT	33	106	172	100	16	6
2"	50	131316PCT	38	123	199	122	16	6
2½"	65	131317PCT	44	144	232	148	16	2
3"	80	131318PCT	52	149	253	148	16	2



Body made of UPVC.  
 Spring made of stainless steel.  
 Unions are designed to be unscrewed with patented fitvalf ball valve handle.  
 Horizontal or vertical installation.  
 Connection with loose flange DIN 8063.

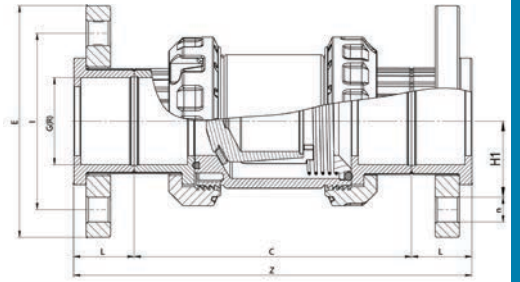

## Spring Check Valve

### Flange Connection

G(R)	DN	inch	Code	E	I	L	Z	C	H1	n	PN	Box
50	40	1½"	131315F	150	110	38	248	172	46	18	16	2
63	50	2"	131316F	167	127	42,5	282	197	54,5	18	16	1
75	65	2½"	131317F	186	145	47	326	232	63,5	18	16	1
90	80	3"	131318F	202	163	58	369	253	72	19,5	16	1



Body made of polycarbonate.  
 Transparent view.  
 Spring made of stainless steel.  
 Unions are designed to be unscrewed with patented fitvalf ball valve handle.  
 Horizontal or vertical installation.  
 Connection with loose flange DIN 8063.

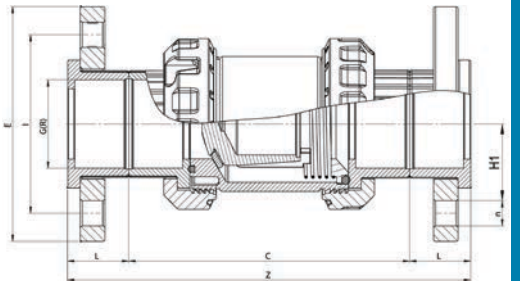

## Spring Transparent Check Valve

### Flange Connection

G(R)	DN	inch	Code	E	I	L	Z	C	H1	n	PN	Box
50	40	1½"	131315PCF	150	110	38	248	172	46	18	16	2
63	50	2"	131316PCF	167	127	42,5	282	197	54,5	18	16	1
75	65	2½"	131317PCF	186	145	47	326	232	63,5	18	16	1
90	80	3"	131318PCF	202	163	58	369	253	72	19,5	16	1



Body & ball made of UPVC.  
 Excellent chemical resistance due to nonmetallic structure.  
 Suitable to be installed vertical position.  
 PN 16.

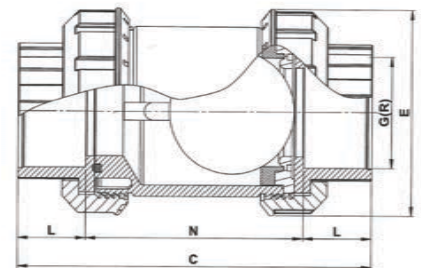

## Ball Check Valve

### Solvent Cement

\*Please ask code/price for threaded connection.

G	DN	Code	L	N	C	E	PN	Box
20	16	131350	20,5	64	105	51,3	16	35
25	20	131351	25	66,5	116,5	65,5	16	35
32	25	131352	28	74,5	130,5	73,7	16	20
40	32	131353	29,5	89,5	148,5	86,8	16	12
50	40	131354	34	100,5	168,5	102	16	6
63	50	131355	40	109	189	119,8	16	6



Body made of UPVC.  
 O-rings from EPDM.  
 Low pressure drop due to wide damper opening distance.  
 Damper closure with spring.  
 Spring from Stainless Steel.  
 Vertical or horizontal installation.

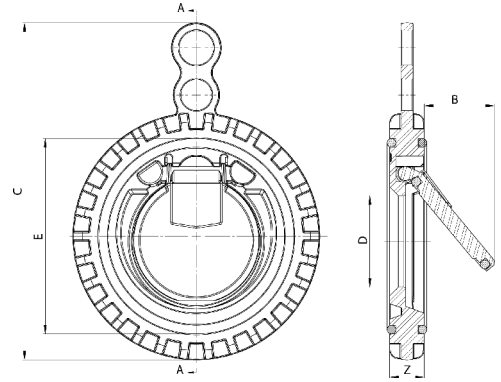

## Wafer Check Valve

d	DN	Code	inch	D	E	C	Z	B	PN	Box
90	80	131530	3"	53	113	196	20	45	10	1
110	100	131531	4"	70	140	219	23	62	10	1
125	110	131532	-	91	161	251	23	90	10	1
140	125	131533	5"	91	161	251	23	70	10	1
160	150	131534	6"	100	202	281	25	100	10	1
200	175	131535	-	125	240	330	33	152	10	1
225	200	131536	8"	125	240	330	33	160	10	1
250	250	131537	10"	168	292	394	38	193	10	1
280	250	131538	-	168	292	394	38	204	10	1
315	300	131539	12"	220	365	380	43	225	10	1



Made of UPVC  
 Screws from AISI 316 Stainless Steel  
 Easy maintenance by dismounting screws

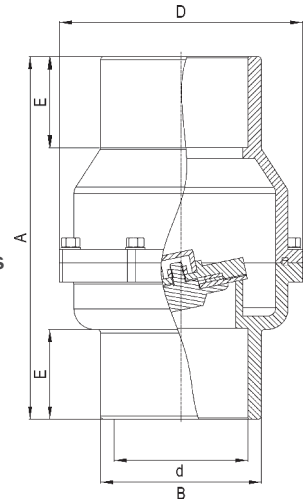

## Swing Check Valve Solvent Cement

d	DN	Code	A	B	D	E	PN	Box
50	40	131499Y	146	65	120		16	6
63	50	131500Y	160	80	141	37	16	6
75	65	131501Y	192	95	150	45	16	2
90	80	131502Y	232	112	178	55	16	2
110	100	131503Y	296	135	202	74	16	1



Body made of UPVC.  
 O-rings from EPDM.  
 Low pressure drop due to wide damper opening distance.  
 Damper closure with spring.  
 Spring from stainless steel.  
 Complete with flange set including steel screws.

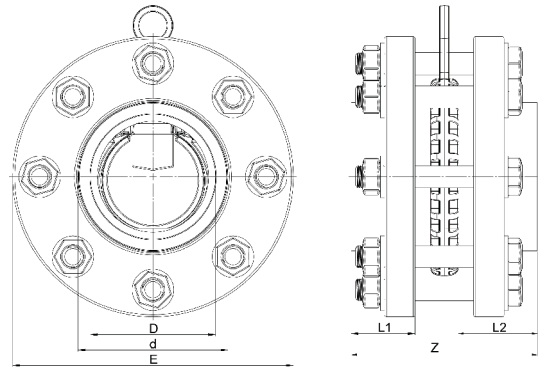

- SS316 screw set is optional.

## Wafer Check Valve Complete with Flange Set

D	DN	Code	d	E	L1	L2	Z	PN	Box
90	80	131502	107	202	46	57	133	10	1
110	100	131503	129,5	222	54,5	65	153	10	1
125	110	131504	147	251	64,5	75	173	10	1
140	125	131505	100,5	251	66,5	81	185	10	1
160	150	131506	189	285	74	90	205	10	1
200	175	131507	225	347	89	113	259	10	1
225	200	131508	250	341	100	125	283	10	1
250	250	131509	276	389	130	147	343	10	1
280	250	131510	305	400	145	105	379	10	1
315	300	131511	343	565	103	185	415	10	1



Body made of UPVC.  
 Lid from polycarbonate for transparent view.  
 Large housing.  
 Low pressure drop due to wide damper opening.  
 Easy top access without dismounting from pipeline.  
 Horizontal or vertical installation.

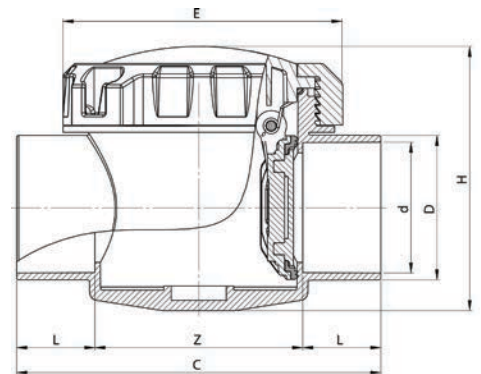

## Transparent Swing Check Valve Solvent Cement

d	Code	C	D	E	L	Z	H	PN	Box
50	131501G	-	-	-	I N	2 0 2 6	-	-	-
63	131500G	177	70	142	38	101	128	10	6



# UPVC BUTTERFLY VALVES



**Our new butterfly valve for regulating flow, specifically designed for water applications.**

- Disc in PVC-U with through shaft
- Zinc plated square section steel stem completely isolated from the fluid complying with standard
- Can also be installed as a bottom discharge valve or tank dump valve
- Valve material compatibility (PVC-U) with swimming pool, water treatment, agriculture irrigation, drinking water and other food substances according to current regulations
- Possibility of directly installing a gearbox or pneumatic and/or electric actuators with a standard drilling pattern according to standard ISO 5211 F05, F07, F10
- Sensitive, angular adjustment for flow regulation
- Option to put security padlock



Product Video

Technical specifications

<b>Construction</b>	Bi-directional centric butterfly valve
<b>Size range</b>	DN 50 / 200
<b>Nominal pressure</b>	<b>Wafer version</b> DN 40 / 50: PN 16 with water at 20 °C DN 65/200: PN 10 with water at 20 °C
<b>Temperature range</b>	Max 50 °C
<b>Reference standards</b>	<b>Flanging system:</b> EN ISO 1452, EN ISO 15493, DIN 2501, ISO 7005-1, EN 1092-1, ANSI B16.5 Cl.150
<b>Riferimenti reference standards</b>	<b>Construction criteria:</b> EN ISO 16136, EN ISO 1452, EN ISO 15493 <b>Test methods and requirements:</b> ISO 9393 <b>Actuator couplings:</b> ISO 5211
<b>Valve material</b>	<b>Body:</b> PVC-U <b>Disc:</b> PVC-U <b>Handle:</b> ABS <b>Stem:</b> Zinc plated carbon steel (C45). On request STAINLESS steel AISI 316
<b>Seal material</b>	<b>Liner:</b> EPDM, FKM. On request NBR
<b>Control option</b>	Hand lever operated; Gearbox, pneumatic actuator, electric actuator





Enhanced ergonomic grip.  
 Handle from ABS.  
 The valve can be positioned in desired angle by the help of handle clutches.  
 Liner from EPDM.  
 Security padlock hole.  
 Shaft from galvanized steel.

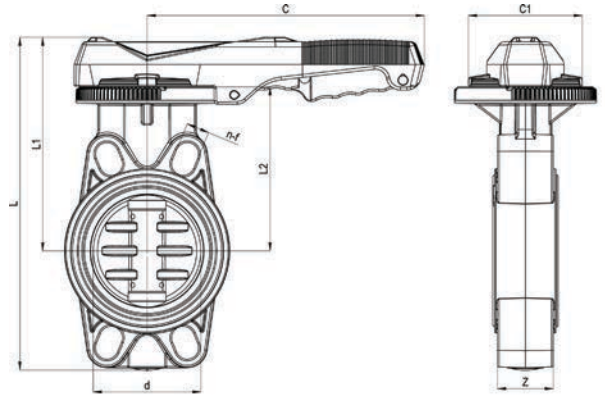

## Butterfly Valve without Flange Set

- SS316 shaft optional

mm	DN	inch	Code	d	C	C1	L	L1	L2	n-F	Z	PN	Box
63	50	2"	131620	51	185	72	220	147	112	19-27	38	10	10
75	65	2½"	131621	69	209	86	239	158	119	19-27	41	10	10
90	80	3"	131622	78	209	86	264	172	134	19-26	44	10	8
110	100	4"	131623	101	255	105	307	195	150	21-31	51	10	5
125	110	-	131624	126	255	105	340	215	167	24-29	59	10	4
140	125	5"	131625	126	255	105	340	215	167	24-29	59	10	4
160	150	6"	131626	146	310	105	365	228	181	25-31	65	10	3
200	200	-	131627	200	335	119	452	290	233	22-30	63	10	3
225	200	8"	131628	200	335	119	452	290	233	22-30	63	10	1
250	250	10"	131629	250	310	155	450	325	165	10-25	100	10	1
280	250	-	131630	280	310	155	480	340	195	10-25	110	10	1
315	300	12"	131631	300	320	155	500	350	215	10-25	120	10	1



Enhanced ergonomic grip.  
 Handle from ABS.  
 The valve can be positioned in desired angle by the help of handle clutches.  
 Liner from EPDM.  
 Security padlock hole.  
 Shaft from galvanized steel.  
 Complete with flanges, bolts and screw set.

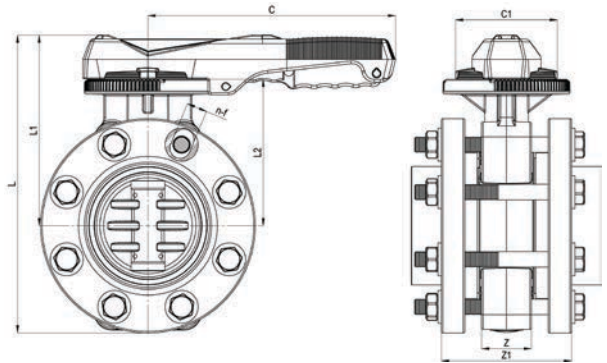

## Butterfly Valve Complete with Flange Set

- SS316 shaft optional.  
 - SS316 screw set is optional.

mm	DN	Code	d	C	C1	L	L1	L2	n-F	Z	Z1	PN	Box
63	50	131600	51	185	72	220	147	112	19-27	38	128	10	1
75	65	131601	69	209	86	239	158	119	19-27	41	142	10	1
90	80	131602	78	209	86	264	172	134	19-26	44	167	10	1
110	100	131603	101	255	105	307	195	150	21-31	51	190	10	1
125	110	131604	126	255	105	340	215	167	24-29	59	218	10	1
140	125	131605	126	255	105	340	215	167	24-29	59	230	10	1
160	150	131606	146	225	105	365	228	181	25-31	65	256	10	1
200	175	131607	200	335	119	452	290	233	22-30	63	305	10	1
225	200	131608	200	335	119	452	290	233	22-30	63	330	10	1
250	250	131609	250	310	155	450	325	165	10-25	100	395	10	1
280	250	131610	280	310	155	480	340	195	10-25	110	440	10	1
315	315	131611	300	320	155	500	350	215	10-25	120	490	10	1

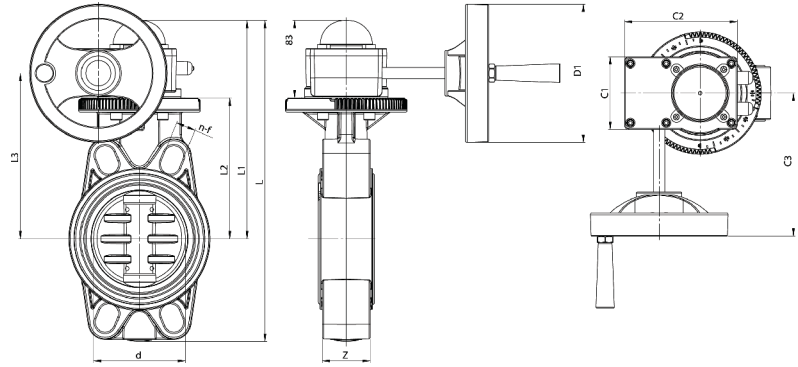

## Butterfly Valve - with Gearbox without Flange Set

Gearbox body made of thermoplastic.  
High strength steel output shaft (stainless steel optional).  
0° - 90° (+/- 5°) mechanical limit.  
OPEN/CLOSE positioner on top.

mm	DN	inch	Code	d	D1	C1	C2	C3	L	L1	L2	L3	n-F	Z
63	50	2"	131640	51	148	78	122	153	268	195	112	139	19-27	38
75	65	2½"	131641	69	148	78	122	153	284	202	119	146	19-27	41
90	80	3"	131642	78	148	78	122	153	309	217	134	161	19-26	44
110	100	4"	131643	101	148	78	122	153	344	233	150	177	21-31	51
125	110	-	131644	126	148	78	122	153	375	250	167	194	26-29	59
140	125	5"	131645	126	148	78	122	153	375	250	167	194	24-29	59
160	150	6"	131646	146	148	78	122	153	400	264	181	208	25-31	65
200	175	-	131647	200	148	78	122	153	478	317	233	260	22-30	63
225	200	8"	131648	200	148	78	122	153	478	317	233	260	22-30	63

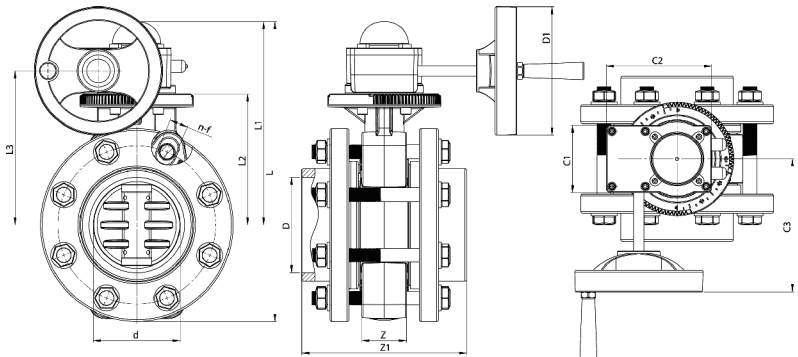

## Butterfly Valve - with Gearbox Complete with Flange Set

Gearbox body made of thermoplastic.  
High strength steel output shaft (stainless steel optional).  
0° - 90° (+/- 5°) mechanical limit.  
OPEN/CLOSE positioner on top.  
Complete with flanges, bolts and screw set.  
- SS 316 screw set is optional.

mm	DN	Code	d	D1	C1	C2	C3	L	L1	L2	L3	n-F	Z	Z1
63	50	131660	51	148	78	122	153	268	195	112	139	19-27	38	128
75	65	131661	69	148	78	122	153	284	202	119	146	19-27	41	142
90	80	131662	78	148	78	122	153	309	217	134	161	19-26	44	167
110	100	131663	101	148	78	122	153	344	233	150	177	21-31	51	190
125	110	131664	126	148	78	122	153	375	250	167	194	26-29	59	218
140	125	131665	126	148	78	122	153	375	250	167	194	24-29	59	230
160	150	131666	146	148	78	122	153	400	264	181	208	25-31	65	256
200	175	131667	200	148	78	122	153	478	317	233	260	22-30	63	305
225	200	131668	200	148	78	122	153	478	317	233	260	22-30	63	330



# UPVC ACTUATED BALL VALVES



Actuator mounting kit made of UPVC.  
Connections comply to ISO5211.  
M6 screw holes for actuator connection.

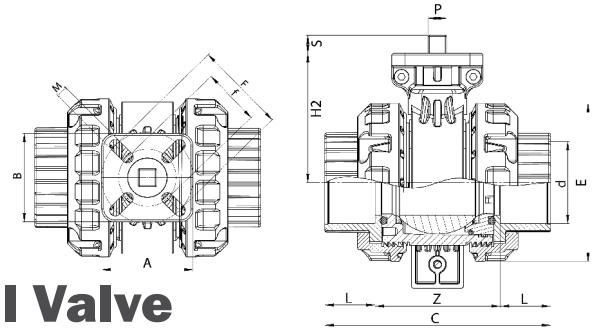

## Actuator Mountable Ball Valve Solvent Cement

d	DN	Code	A	B	C	E	H2	L	M(metric)	ISO5211	f-F	P	S	Z	PN
20	16	131111LA	52	52	93	64,5	54	20	6	F03-F05	36-50	11	14	53	16
25	20	131112LA	52	52	93	64,5	54	20	6	F03-F05	36-50	11	14	53	16
32	25	131113LA	52	52	107	75	61	23,5	6	F03-F05	36-50	11	14	60	16
40	32	131114LA	52	52	122	88	72	26	6	F03-F05	36-50	11	14	70	16
50	40	131115LA	70	68	146	100	92	33	8	F05-F07	50-70	14	17	80	16
63	50	131116LA	70	68	169	122	100	38	8	F05-F07	50-70	14	17	93	16
75	65	131117LA	70	68	197	143	107	44	8	F05-F07	50-70	14	17	109	16
90	80	131118LA	70	68	221	143	107	52	8	F05-F07	50-70	14	17	114	16
110	100	131119LA	105	105	286	226	154	60	10	F07-F10	70-102	17	19	166	16



Actuator mounting kit made of UPVC.  
Connections comply to ISO5211.  
M6 screw holes for actuator connection.  
One side BSP female threaded.

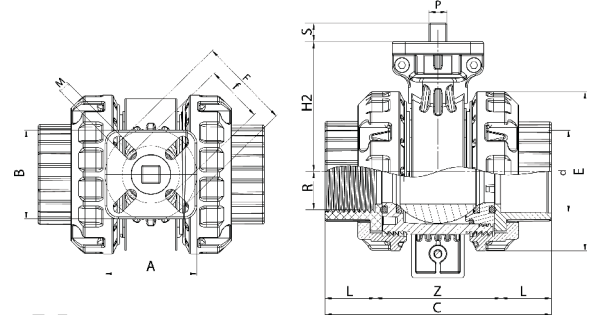

## Actuator Mountable Ball Valve Solvent Cement x Female Threaded

d	R	DN	Code	A	B	C	E	H2	L	M(metric)	ISO5211	f-F	P	S	Z	PN
20	½"	16	131111LAT1	52	52	93	64,5	54	20	6	F03-F05	36-50	11	14	53	16
25	¾"	20	131112LAT1	52	52	93	64,5	54	20	6	F03-F05	36-50	11	14	53	16
32	1"	25	131113LAT1	52	52	107	75	61	23,5	6	F03-F05	36-50	11	14	60	16
40	1¼"	32	131114LAT1	52	52	122	88	72	26	6	F03-F05	36-50	11	14	70	16
50	1½"	40	131115LAT1	70	68	146	100	92	33	8	F05-F07	50-70	14	17	80	16
63	2"	50	131116LAT1	70	68	169	122	100	38	8	F05-F07	50-70	14	17	93	16
75	2½"	65	131117LAT1	70	68	197	143	107	44	8	F05-F07	50-70	14	17	109	16
90	3"	80	131118LAT1	70	68	221	143	107	52	8	F05-F07	50-70	14	17	114	16
110	4"	100	131119LAT1	105	105	286	226	154	60	10	F07-F10	70-102	17	19	166	16



Actuator mounting kit made of UPVC.  
Connections comply to ISO5211.  
M6 screw holes for actuator connection.  
Two sides BSP threaded.

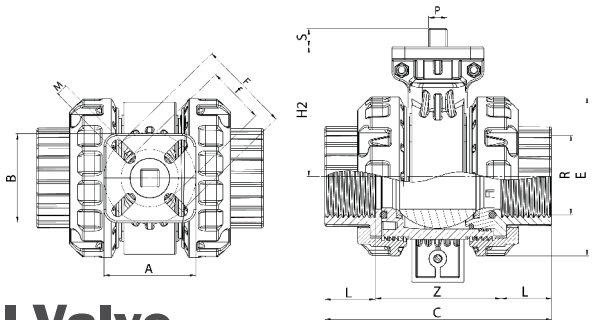

## Actuator Mountable Ball Valve Female Threaded x Female Threaded

R	DN	Code	A	B	C	E	H2	L	M(metric)	ISO5211	f-F	P	S	Z	PN
½"	16	131111LAT	52	52	93	64,5	54	20	6	F03-F05	36-50	11	14	53	16
¾"	20	131112LAT	52	52	93	64,5	54	20	6	F03-F05	36-50	11	14	53	16
1"	25	131113LAT	52	52	107	75	61	23,5	6	F03-F05	36-50	11	14	60	16
1¼"	32	131114LAT	52	52	122	88	72	26	6	F03-F05	36-50	11	14	70	16
1½"	40	131115LAT	70	68	146	100	92	33	8	F05-F07	50-70	14	17	80	16
2"	50	131116LAT	70	68	169	122	100	38	8	F05-F07	50-70	14	17	93	16
2½"	65	131117LAT	70	68	197	143	107	44	8	F05-F07	50-70	14	17	109	16
3"	80	131118LAT	70	68	221	143	107	52	8	F05-F07	50-70	14	17	114	16
4"	100	131119LAT	105	105	286	226	154	60	10	F07-F10	70-102	17	19	166	16



Noncorrosive thermoplastic actuator body.  
 0° - 90° working angle.  
 ON/OFF position indicator.  
 Manual control with wrench.  
 Internal thermal protection. IP67.

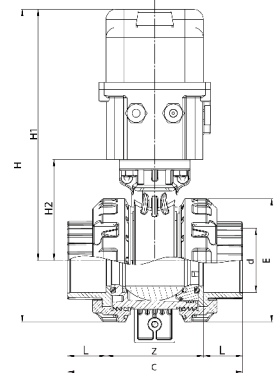
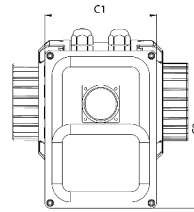

## Electric Actuated Ball Valve

### Solvent Cement - 24V DC ON/OFF

d	DN	Code	C	C1	C2	E	H	H1	H2	L	Z	PN	Box
20	16	131111LEA	93	96	137	64,5	214	182	54	20	53	16	1
25	20	131112LEA	93	96	137	64,5	214	182	54	20	53	16	1
32	25	131113LEA	107	96	137	75	228	190	61	23,5	60	16	1
40	32	131114LEA	122	96	137	88	241	197	72	26	70	16	1
50	40	131115LEA	146	110	155	100	289	239	92	33	80	16	1
63	50	131116LEA	169	110	155	122	309	248	100	38	93	16	1
75	65	131117LEA	197	110	155	143	333	262	107	44	109	16	1
90	80	131118LEA	221	110	155	143	333	262	107	52	114	16	1
110	100	131119LEA	286	110	155	226	415	309	154	60	166	16	1



Noncorrosive thermoplastic actuator body.  
 0°-90° working angle.  
 ON/OFF position indicator.  
 Manual control with wrench.  
 Internal thermal protection. IP67.  
 One side BSP female threaded.

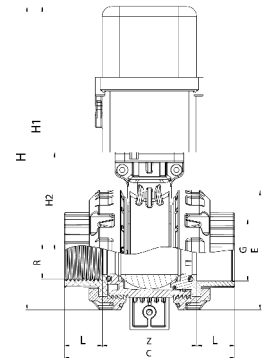
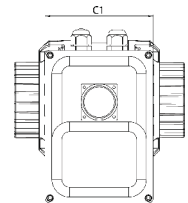

\*C1, C2, H and H1 values may vary.



## Electric Actuated Ball Valve

### Solvent Cement x Female Threaded - 24V DC ON/OFF

d	R	DN	Code	C	C1	C2	E	H	H1	H2	L	Z	PN	Box
20	½"	16	131111LEAT1	93	96	137	64,5	214	182	54	20	53	16	1
25	¾"	20	131112LEAT1	93	96	137	64,5	214	182	54	20	53	16	1
32	1"	25	131113LEAT1	107	96	137	75	228	190	61	23,5	60	16	1
40	1¼"	32	131114LEAT1	122	96	137	88	241	197	72	26	70	16	1
50	1½"	40	131115LEAT1	146	110	155	100	289	239	92	33	80	16	1
63	2"	50	131116LEAT1	169	110	155	122	309	248	100	38	93	16	1
75	2½"	65	131117LEAT1	197	110	155	143	333	262	107	44	109	16	1
90	3"	80	131118LEAT1	221	110	155	143	333	262	107	52	114	16	1
110	4"	100	131119LEAT1	286	110	155	226	415	309	154	60	166	16	1



Noncorrosive thermoplastic actuator body.  
 0°-90° working angle.  
 ON/OFF position indicator.  
 Manual control with wrench.  
 Internal thermal protection. IP67.  
 Two sides BSP female threaded.

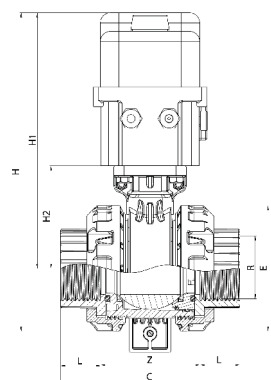
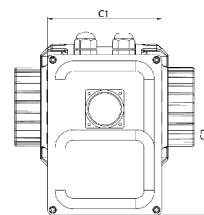

\*C1, C2, H and H1 values may vary.



## Electric Actuated Ball Valve

### Female Threaded x Female Threaded - 24V DC ON/OFF

R	DN	Code	C	C1	C2	E	H	H1	H2	L	Z	PN	Box
½"	16	131111LEAT	93	96	137	64,5	214	182	54	20	53	16	1
¾"	20	131112LEAT	93	96	137	64,5	214	182	54	20	53	16	1
1"	25	131113LEAT	107	96	137	75	228	190	61	23,5	60	16	1
1¼"	32	131114LEAT	122	96	137	88	241	197	72	26	70	16	1
1½"	40	131115LEAT	146	110	155	100	289	239	92	33	80	16	1
2"	50	131116LEAT	169	110	155	122	309	248	100	38	93	16	1
2½"	65	131117LEAT	197	110	155	143	333	262	107	44	109	16	1
3"	80	131118LEAT	221	110	155	143	333	262	107	52	114	16	1
4"	100	131119LEAT	286	110	155	226	415	309	154	60	166	16	1

\*C1, C2, H and H1 values may vary.



Made from extruded aluminum.  
 Shaft from cadmium plating steel.  
 Pistons from casted aluminum.  
 ON/OFF position indicator.  
 Quick OPEN/CLOSE compared to electric actuators.  
 Valve fixation according to ISO5211.

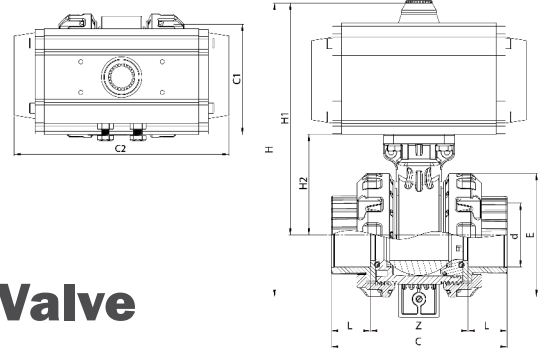

## Pneumatic Actuated Ball Valve Solvent Cement - Single Acting

d	DN	Code	C	C1	C2	E	H	H1	H2	L	Z	PN	Box
20	16	131111LPA1	93	80	150	64,5	184	152	54	20	53	16	1
25	20	131112LPA1	93	80	150	64,5	184	152	54	20	53	16	1
32	25	131113LPA1	107	80	150	75	197	160	61	23,5	60	16	1
40	32	131114LPA1	122	80	150	88	211	167	72	26	70	16	1
50	40	131115LPA1	146	94	188	100	261	211	92	33	80	16	1
63	50	131116LPA1	169	94	188	122	281	220	100	38	93	16	1
75	65	131117LPA1	197	124	268	143	315	244	107	44	109	16	1
90	80	131118LPA1	221	124	268	143	315	244	107	52	114	16	1
110	100	131119LPA1	286	149	322	226	450	337	154	60	166	16	1



Made from extruded aluminum.  
 Shaft from cadmium plating steel.  
 Pistons from casted aluminum.  
 ON/OFF position indicator.  
 Quick OPEN/CLOSE compared to electric actuators.  
 Valve fixation according to ISO5211.  
 One side BSP female threaded.

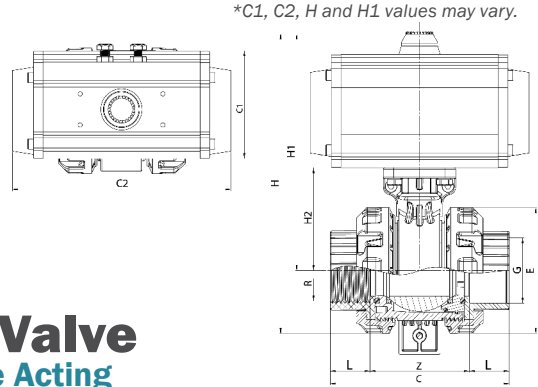

\*C1, C2, H and H1 values may vary.

## Pneumatic Actuated Ball Valve Solvent Cement x Female Threaded - Single Acting

d	R	DN	Code	C	C1	C2	E	H	H1	H2	L	Z	PN	Box
20	½"	16	131111LPA1T1	93	80	150	64,5	184	152	54	20	53	16	1
25	¾"	20	131112LPA1T1	93	80	150	64,5	184	152	54	20	53	16	1
32	1"	25	131113LPA1T1	107	80	150	75	197	160	61	23,5	60	16	1
40	1¼"	32	131114LPA1T1	122	80	150	88	211	167	72	26	70	16	1
50	1½"	40	131115LPA1T1	146	94	188	100	261	211	92	33	80	16	1
63	2"	50	131116LPA1T1	169	94	188	122	281	220	100	38	93	16	1
75	2½"	65	131117LPA1T1	197	124	268	143	315	244	107	44	109	16	1
90	3"	80	131118LPA1T1	221	124	268	143	315	244	107	52	114	16	1
110	4"	100	131119LPA1T1	286	149	322	226	450	337	154	60	166	16	1



Made from extruded aluminum.  
 Shaft from cadmium plating steel.  
 Pistons from casted aluminum.  
 ON/OFF position indicator.  
 Quick OPEN/CLOSE compared to electric actuators.  
 Valve fixation according to ISO5211.  
 Two sides BSP female threaded.

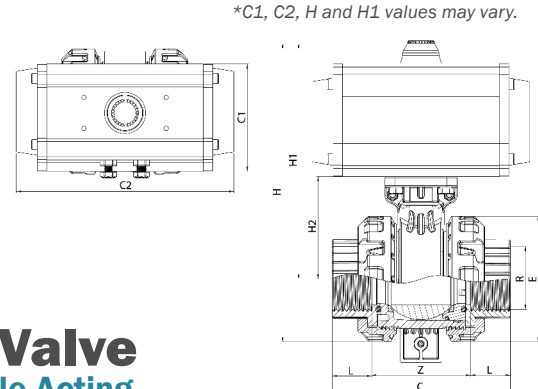

\*C1, C2, H and H1 values may vary.

## Pneumatic Actuated Ball Valve Female Threaded x Female Threaded - Single Acting

R	DN	Code	C	C1	C2	E	H	H1	H2	L	Z	PN	Box
½"	16	131111LPA1T	93	80	150	64,5	184	152	54	20	53	16	1
¾"	20	131112LPA1T	93	80	150	64,5	184	152	54	20	53	16	1
1"	25	131113LPA1T	107	80	150	75	197	160	61	23,5	60	16	1
1¼"	32	131114LPA1T	122	80	150	88	211	167	72	26	70	16	1
1½"	40	131115LPA1T	146	94	188	100	261	211	92	33	80	16	1
2"	50	131116LPA1T	169	94	188	122	281	220	100	38	93	16	1
2½"	65	131117LPA1T	197	124	268	143	315	244	107	44	109	16	1
3"	80	131118LPA1T	221	124	268	143	315	244	107	52	114	16	1
4"	100	131119LPA1T	286	149	322	226	450	337	154	60	166	16	1

\*C1, C2, H and H1 values may vary.



Made from extruded aluminum.  
 Shaft from cadmium plating steel.  
 Pistons from casted aluminum.  
 ON/OFF position indicator.  
 Quick OPEN/CLOSE compared to electric actuators.  
 Valve fixation according to ISO5211.

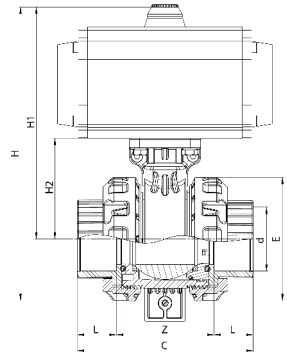
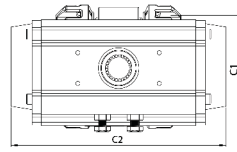

## Pneumatic Actuated Ball Valve

### Solvent Cement - Double Acting

d	DN	Code	C	C1	C2	E	H	H1	H2	L	Z	PN	Box
20	16	131111LPA2	93	80	150	64,5	184	152	54	20	53	16	1
25	20	131112LPA2	93	80	150	64,5	184	152	54	20	53	16	1
32	25	131113LPA2	107	80	150	75	197	160	61	23,5	60	16	1
40	32	131114LPA2	122	80	150	88	211	167	72	26	70	16	1
50	40	131115LPA2	146	94	188	100	261	211	92	33	80	16	1
63	50	131116LPA2	169	94	188	122	281	220	100	38	93	16	1
75	65	131117LPA2	197	124	268	143	315	244	107	44	109	16	1
90	80	131118LPA2	221	124	268	143	315	244	107	52	114	16	1
110	100	131119LPA2	286	149	322	226	450	337	154	60	166	16	1

\*C1, C2, H and H1 values may vary.



Made from extruded aluminum.  
 Shaft from cadmium plating steel.  
 Pistons from casted aluminum.  
 ON/OFF position indicator.  
 Quick OPEN/CLOSE compared to electric actuators.  
 Valve fixation according to ISO5211.  
 One side BSP female threaded.

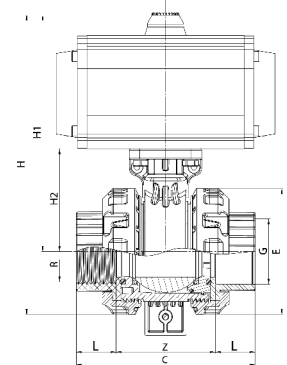
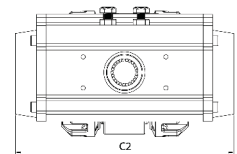

## Pneumatic Actuated Ball Valve

### Solvent Cement x Female Threaded - Double Acting

d	R	DN	Code	C	C1	C2	E	H	H1	H2	L	Z	PN	Box
20	1/2"	16	131111LPA2T1	93	80	150	64,5	184	152	54	20	53	16	1
25	3/4"	20	131112LPA2T1	93	80	150	64,5	184	152	54	20	53	16	1
32	1"	25	131113LPA2T1	107	80	150	75	197	160	61	23,5	60	16	1
40	1 1/4"	32	131114LPA2T1	122	80	150	88	211	167	72	26	70	16	1
50	1 1/2"	40	131115LPA2T1	146	94	188	100	261	211	92	33	80	16	1
63	2"	50	131116LPA2T1	169	94	188	122	281	220	100	38	93	16	1
75	2 1/2"	65	131117LPA2T1	197	124	268	143	315	244	107	44	109	16	1
90	3"	80	131118LPA2T1	221	124	268	143	315	244	107	52	114	16	1
110	4"	100	131119LPA2T1	286	149	322	226	450	337	154	60	166	16	1

\*C1, C2, H and H1 values may vary.



Made from extruded aluminum.  
 Shaft from cadmium plating steel.  
 Pistons from casted aluminum.  
 ON/OFF position indicator.  
 Quick OPEN/CLOSE compared to electric actuators.  
 Valve fixation according to ISO5211.  
 Two sides BSP female threaded.

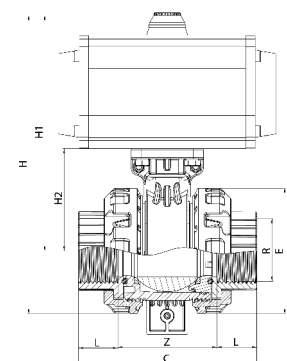
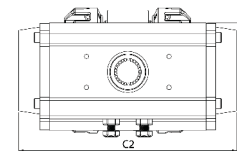

## Pneumatic Actuated Ball Valve

### Female Threaded x Female Threaded - Double Acting

R	DN	Code	C	C1	C2	E	H	H1	H2	L	Z	PN	Box
1/2"	16	131111LPA2T	93	80	150	64,5	184	152	54	20	53	16	1
3/4"	20	131112LPA2T	93	80	150	64,5	184	152	54	20	53	16	1
1"	25	131113LPA2T	107	80	150	75	197	160	61	23,5	60	16	1
1 1/4"	32	131114LPA2T	122	80	150	88	211	167	72	26	70	16	1
1 1/2"	40	131115LPA2T	146	94	188	100	261	211	92	33	80	16	1
2"	50	131116LPA2T	169	94	188	122	281	220	100	38	93	16	1
2 1/2"	65	131117LPA2T	197	124	268	143	315	244	107	44	109	16	1
3"	80	131118LPA2T	221	124	268	143	315	244	107	52	114	16	1
4"	100	131119LPA2T	286	149	322	226	450	337	154	60	166	16	1

\*C1, C2, H and H1 values may vary.



Actuator mounting kit made of UPVC.  
Connections comply to ISO5211.  
M6 screw holes for actuator connection.  
Connection with loose flange DIN 8063.

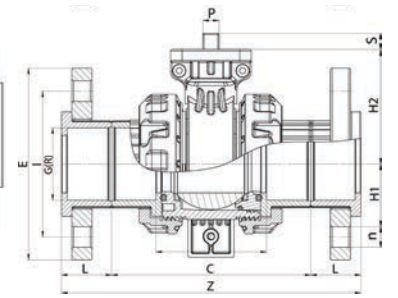
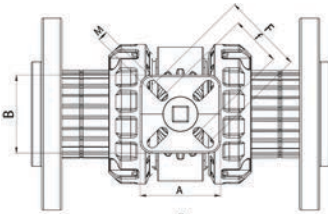

\*C1, C2, H and H1 values may vary.

## Actuator Mountable Ball Valve Both Side Flanged

G	inch	Code	A	B	C	E	I	H1	H2	M(metric)	ISO5211	f-F	P	S	L	Z	n	PN
50	1½"	131115LAF	70	68	146	151	110	46	91	8	F05 - F07	50-70	14	17	38	222	18	16
63	2"	131116LAF	70	68	169	167	127	54,5	100	8	F05 - F07	50-70	14	17	42,5	254	18	16
75	2½"	131117LAF	70	68	197	186	145	63,5	107	8	F05 - F07	50-70	14	17	47	291	18	16
90	3"	131118LAF	70	68	221	202	163	72	107	8	F05 - F07	50-70	14	17	58	337	19,5	16
110	4"	131119LAF	105	105	286	222	182	82	151	10	F07 - F010	70-100	17	19	65	416	17,5	16



Noncorrosive thermoplastic actuator body.  
0° - 90° working angle.  
ON/OFF position indicator.  
Manual control with wrench.  
Internal thermal protection. IP67.  
Connection with loose flange DIN 8063.

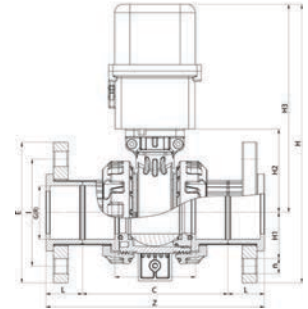
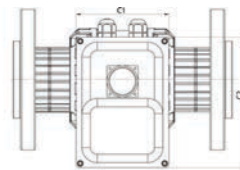

## Electric Actuated Ball Valve Both Side Flanged - 24VDC

G	inch	Code	C	C1	C2	E	I	H1	H2	H3	H	L	Z	n	PN
50	1½"	131115LEAF	146	110	155	151	110	46	91	239	314	38	222	18	16
63	2"	131116LEAF	169	110	155	167	127	54,5	100	248	332	42,5	254	18	16
75	2½"	131117LEAF	197	110	155	186	145	63,5	107	255	348	47	291	18	16
90	3"	131118LEAF	221	110	155	202	163	72	107	255	356	58	337	19,5	16
110	4"	131119LEAF	286			222	182	82	151			65	416	17,5	16

\*C1, C2, H and H1 values may vary.



Made from extruded aluminum.  
Shaft from cadmium plating steel.  
Pistons from casted aluminum.  
ON/OFF position indicator.  
Quick OPEN/CLOSE compared to electric actuators.  
Valve fixation according to ISO5211.  
Connection with loose flange DIN 8063.

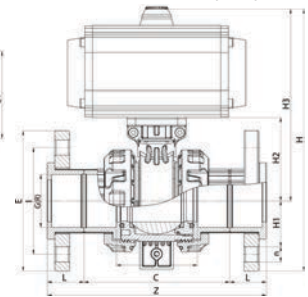
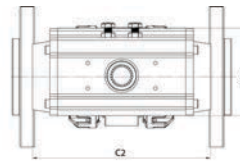

## Pneumatic Actuated Ball Valve Both Side Flanged - Single Acting

G	inch	Code	C	C1	C2	E	I	H1	H2	H3	H	L	Z	n	PN
50	1½"	131115LPA1F	146	94	188	151	110	46	91	211	286	38	222	18	16
63	2"	131116LPA1F	169	94	188	167	127	54,5	100	220	304	42,5	254	18	16
75	2½"	131117LPA1F	197	124	268	186	145	63,5	107	244	337	47	291	18	16
90	3"	131118LPA1F	221	124	268	202	163	72	107	244	345	58	337	19,5	16
110	4"	131119LPA1F	286	149	322	222	182	82	151	337	448	65	416	17,5	16

\*C1, C2, H and H1 values may vary.



Made from extruded aluminum.  
Shaft from cadmium plating steel.  
Pistons from casted aluminum.  
ON/OFF position indicator.  
Quick OPEN/CLOSE compared to electric actuators.  
Valve fixation according to ISO5211.  
Connection with loose flange DIN 8063.

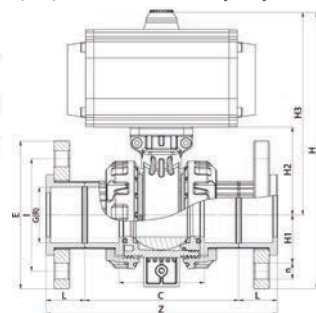
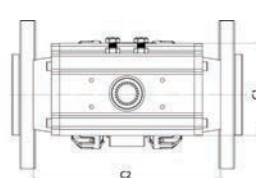

## Pneumatic Actuated Ball Valve Both Side Flanged - Double Acting

G	inch	Code	C	C1	C2	E	I	H1	H2	H3	H	L	Z	n	PN
50	1½"	131115LPA2F	146	94	188	151	110	46	91	211	286	38	222	18	16
63	2"	131116LPA2F	169	94	188	167	127	54,5	100	220	304	42,5	254	18	16
75	2½"	131117LPA2F	197	124	268	186	145	63,5	107	244	337	47	291	18	16
90	3"	131118LPA2F	221	124	268	202	163	72	107	244	345	58	337	19,5	16
110	4"	131119LPA2F	286	149	322	222	182	82	151	337	448	65	416	17,5	16

\*C1, C2, H and H1 values may vary.



Made of UPVC.  
Connection holes according to ISO5211

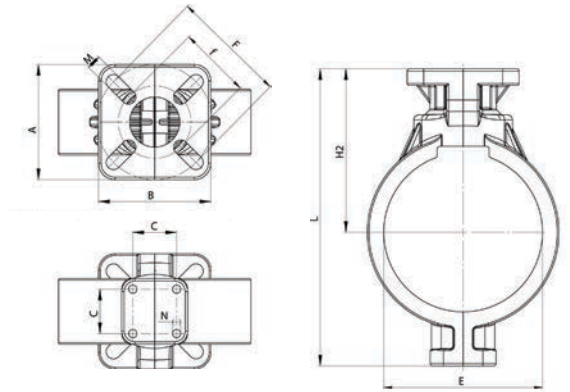

## Clamp for Actuator Usage

mm	inch	Code	A	B	C	E	H2	L	M(metric)	N	ISO5211	f-F	PN	Box
50	1½"	13902	70	68	26,5	81,5	92	165	8	5	F05-F07	50-70	16	17
63	2"	13903	70	68	26,5	96,5	100	180	8	5	F05-F07	50-70	16	17



Standard IP67 enclosure.  
2 pieces mechanical or proximity limit switch.  
3D ON/OFF position indicator.  
Can be mounted on all kind of actuators in the market.  
8 strips on terminal box allows direct connection of Solenoid valve inside the product.

## Limit Switch Box

Code	Description
13900	Limit Switch Box



Standard IP65 enclosure.  
Can be mounted on all kind of actuators in the market.  
Lockable manual control.  
Single coil or double coil alternative.

## Solenoid Valve Namur Type

Code	Description
13901	Namur Type Solenoid Valve



Diaphragm type pressure control valve.  
To be used as back pressure loading or pressure safety valve in dosing systems.  
Diaphragm made of PTFE high corrosion resistance.  
High flow capacity, low pressure loss  
Connection UPVC solvent cement. PN16.

## Pressure Control Valve

Connection	Code
25	13906
32	13907
40	13904
50	13905

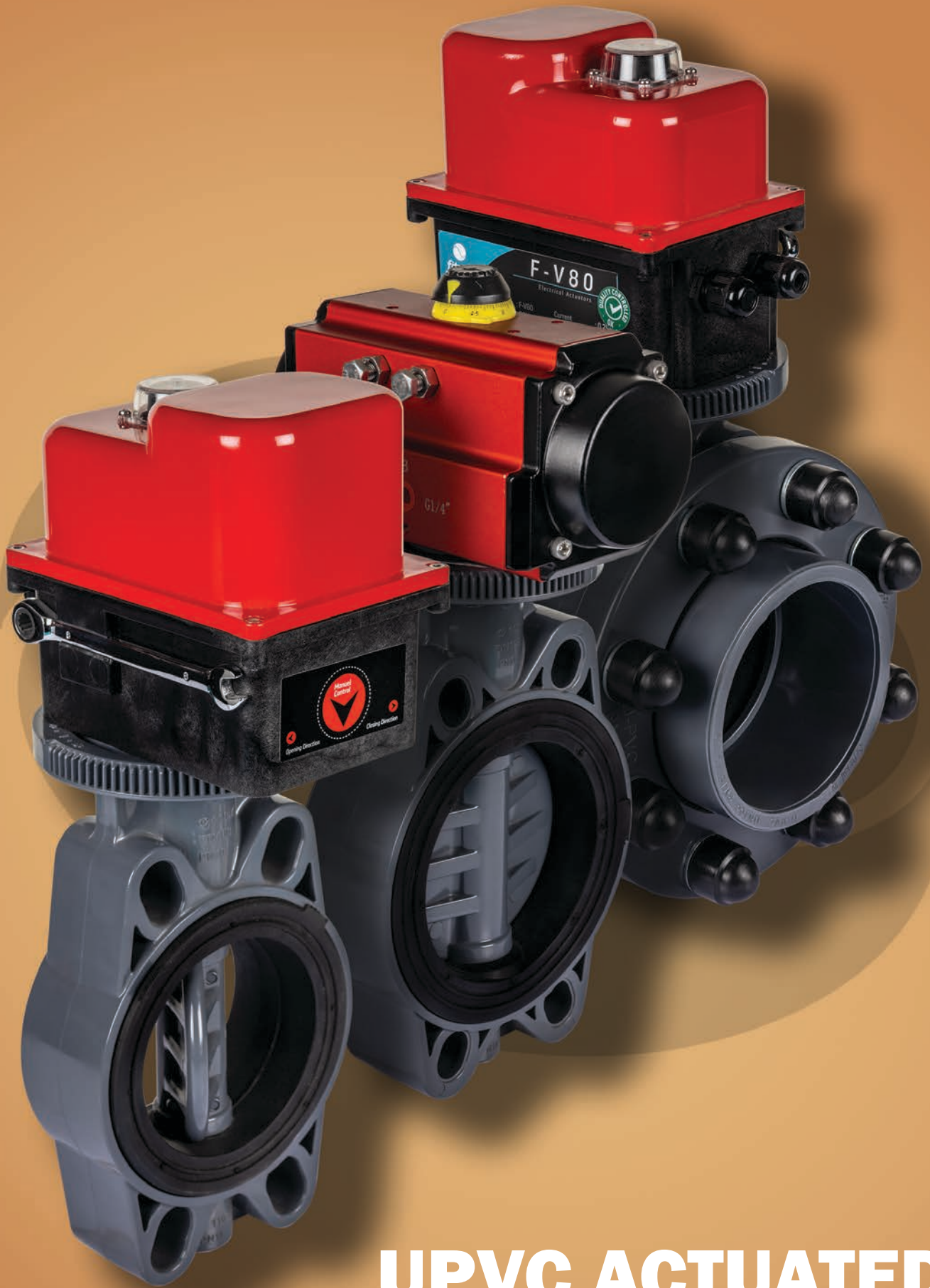

# UPVC ACTUATED BUTTERFLY VALVES

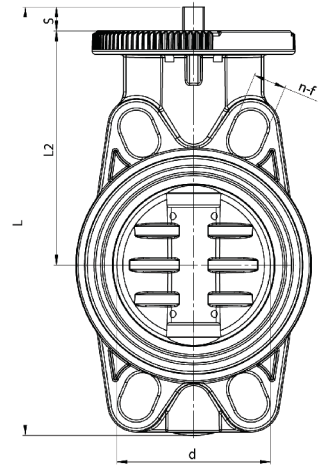
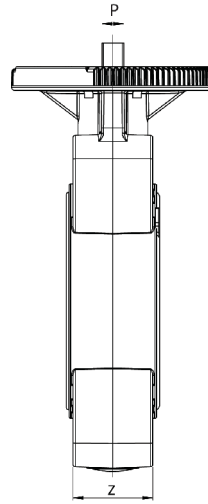
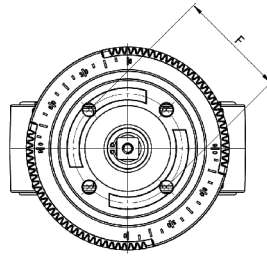

Butterfly valve according to ISO5211 actuator connection.  
Please check technical table for correct torque in NM.



## Butterfly Valve for Actuator Usage without Flange Set

mm	DN	Code	inch	d	ISO5211	F	L	L2	P	S	n-f	Z	PN	NM
63	50	131620A	2"	51	F5	50	196	112	9	12	19-27	38	10	30
75	65	131621A	2½"	69	F5	50	218	119	11	16	19-27	41	10	50
90	80	131622A	3"	78	F7	70	243	134	11	16	19-26	44	10	80
110	100	131623A	4"	101	F7	70	276	150	14	16	21-31	51	10	100
125	125	131624A	-	126	F7	70	308	167	14	16	24-29	59	10	100
140	125	131625A	5"	126	F7	70	308	167	14	16	24-29	59	10	100
160	150	131626A	6"	200	F7	70	332	181	14	16	25-31	55	10	140
200	200	131627A	-	200	F10	102	417	233	22	22	22-30	63	10	200
225	200	131628A	8"	250	F10	102	417	233	22	22	22-30	63	10	200

\*NM value represents the needed torque value of the selected actuator.

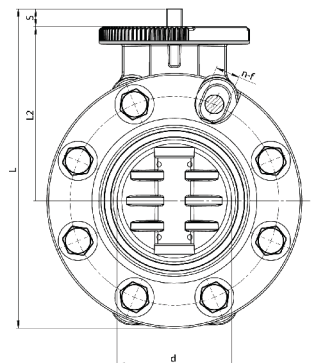
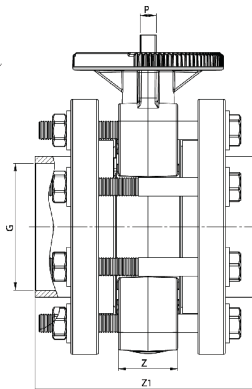
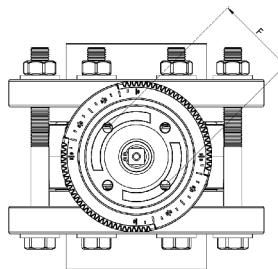

Butterfly valve according to ISO5211 actuator connection.  
Complete with flange, flange adaptor and nuts.  
Please check technical table for correct torque in NM.

- SS316 screw set is optional.



## Butterfly Valve for Actuator Usage Complete with Flange Set

mm	DN	Code	d	ISO5211	F	L	L2	P	S	n-f	Z	Z1	PN	NM
63	50	131600A	51	F5	50	207	112	9	11	19-27	38	128	10	30
75	65	131601A	69	F5	50	229	119	11	16	19-27	41	142	10	50
90	80	131602A	78	F7	70	252	134	11	16	19-26	44	167	10	80
110	100	131603A	101	F7	70	276	150	14	16	21-31	51	190	10	100
125	125	131604A	126	F7	70	308	167	14	16	24-29	59	218	10	100
140	125	131605A	126	F7	70	308	167	14	16	24-29	59	230	10	100
160	150	131606A	200	F7	70	339	181	14	16	25-31	55	256	10	140
200	200	131607A	200	F10	102	426	233	22	22	22-30	63	305	10	200
225	200	131608A	250	F10	102	426	233	22	22	22-30	63	330	10	200

\*NM value represents the needed torque value of the selected actuator.

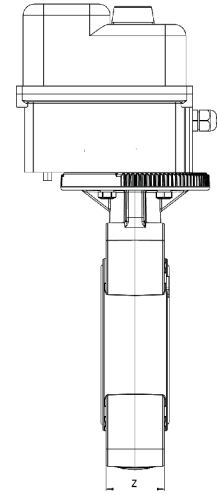
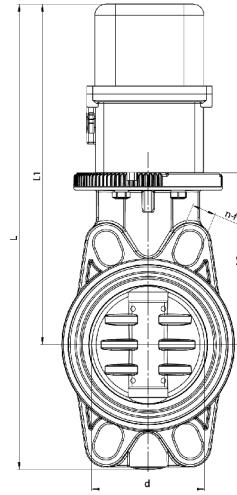
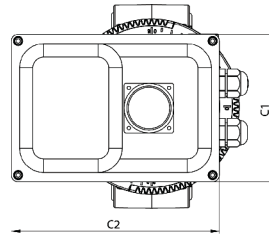

Noncorrosive thermoplastic actuator body.  
0° - 90° working angle.  
ON/OFF position indicator.  
Manual control with wrench.  
Internal thermal protection. IP67.



## Electric Actuated Butterfly Valve without Flange Set - 24 VDC ON/OFF

mm	DN	Code	inch	d	C1	C2	L	L1	L2	n-F	Z	PN
63	50	131620M11	2"	51	110	155	333	260	112	19-27	38	10
75	65	131621M11	2½"	69	110	155	350	267	119	19-27	41	10
90	80	131622M11	3"	78	110	155	375	282	134	19-26	44	10
110	100	131623M11	4"	101	110	155	415	305	150	21-31	51	10
125	125	131624M2	-	126	110	155	447	322	167	24-29	59	10
140	125	131625M2	5"	126	110	155	447	322	167	24-29	59	10
160	150	131626M2	6"	200	110	155	470	336	181	25-31	55	10
200	200	131627M2	-	200	110	155	550	386	233	22-30	63	10
225	200	131628M2	8"	250	110	155	550	386	233	22-30	63	10

\*C1, C2, L and L1 values may vary.

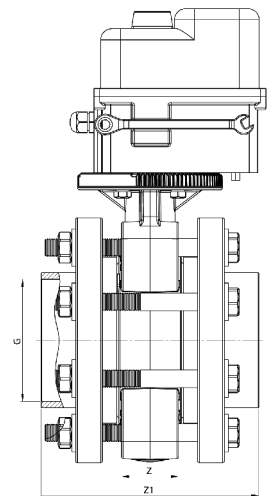
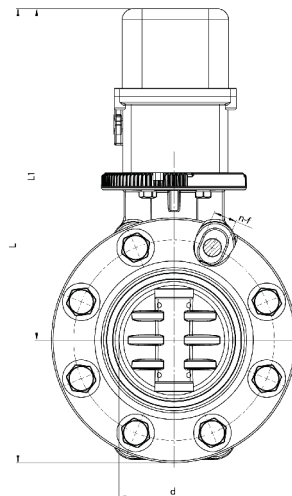
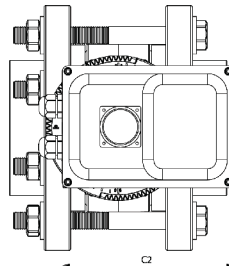

Noncorrosive thermoplastic actuator body.  
0° - 90° working angle.  
ON/OFF position indicator.  
Manual control with wrench.  
Internal thermal protection. IP67.

- SS316 screw set is optional.



## Electric Actuated Butterfly Valve Complete Flange Set - 24 VDC ON/OFF

G	DN	Code	d	C1	C2	L	L1	L2	n-F	Z	Z1	PN
63	50	131600M11	51	110	155	345	260	112	19-27	38	128	10
75	65	131601M11	69	110	155	360	267	119	19-27	41	142	10
90	80	131602M11	78	110	155	383	282	134	19-26	44	167	10
110	100	131603M11	101	110	155	415	305	150	21-31	51	190	10
125	125	131604M2	126	110	155	447	322	167	24-29	59	218	10
140	125	131605M2	126	110	155	447	322	167	24-29	59	230	10
160	150	131606M2	200	110	155	478	336	181	25-31	55	256	10
200	200	131607M2	200	110	155	560	386	233	22-30	63	305	10
225	200	131608M2	250	110	155	560	386	233	22-30	63	330	10

\*C1, C2, L and L1 values may vary.

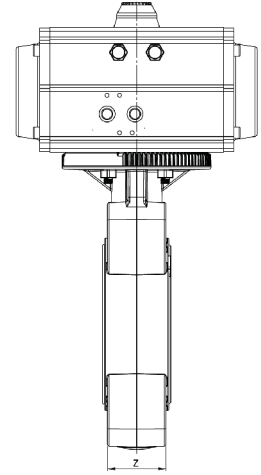
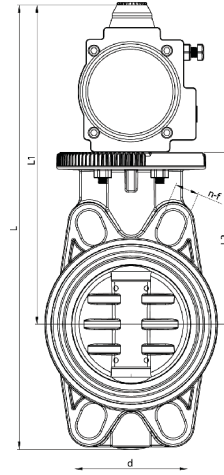
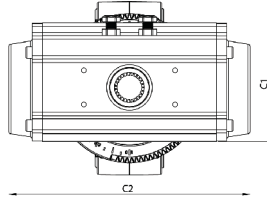

Made from extruded aluminum. Shaft from cadmium plating steel. Pistons from casted aluminum.  
 ON/OFF position indicator.  
 Quick OPEN/CLOSE compared to electric actuators.  
 Valve fixation according to ISO5211.

## Pneumatic Actuated Butterfly Valve Single Acting - without Flange Set

mm	DN	Code	inch	d	C1	C2	L	L1	L2	n-F	Z	PN
63	50	131620PA	2"	51	90	172	293	221	112	19-27	38	10
75	65	131621PA	2½"	69	90	172	310	227	119	19-27	41	10
90	80	131622PA	3"	78	94	188	346	254	134	19-26	44	10
110	100	131623PA	4"	101	117	221	390	280	150	21-31	51	10
125	125	131624PA	-	126	124	268	430	305	167	24-29	59	10
140	125	131625PA	5"	126	124	268	430	305	167	24-29	59	10
160	150	131626PA	6"	200	131	279	470	335	181	25-31	55	10
200	200	131627PA	-	200	149	322	580	420	233	22-30	63	10
225	200	131628PA	8"	250	149	322	580	420	233	22-30	63	10

\*C1, C2, L and L1 values may vary.

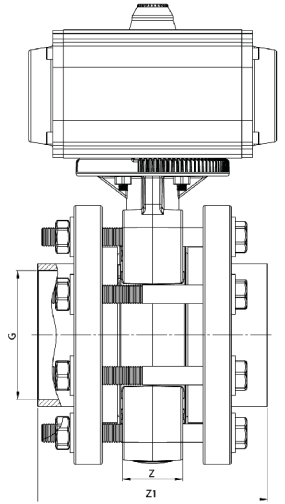
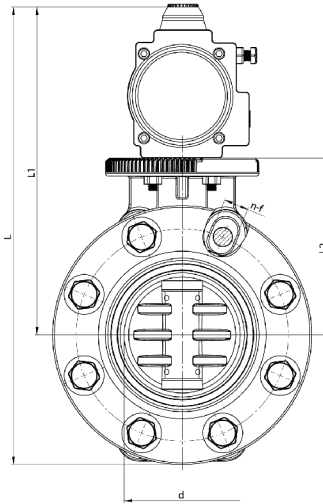
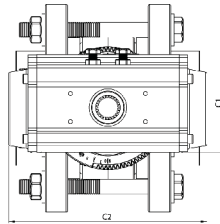

Made from extruded aluminum. Shaft from cadmium plating steel. Pistons from casted aluminum.  
 Quick OPEN/CLOSE compared to electric actuators.  
 Valve fixation according to ISO5211.  
 Complete with flange, flange adaptor and screw set.

- SS316 screw set is optional.

## Pneumatic Actuated Butterfly Valve Single Acting - Complete with Flange Set

G	DN	Code	d	C1	C2	L	L1	L2	n-F	Z	Z1	PN
63	50	131600PA	51	90	172	305	221	112	19-27	38	128	10
75	65	131601PA	69	90	172	320	227	119	19-27	41	142	10
90	80	131602PA	78	94	188	355	254	134	19-26	44	167	10
110	100	131603PA	101	117	221	390	280	150	21-31	51	190	10
125	125	131604PA	126	124	268	430	305	167	24-29	59	218	10
140	125	131605PA	126	124	268	430	305	167	24-29	59	230	10
160	150	131606PA	200	131	279	480	335	181	25-31	55	256	10
200	200	131607PA	200	149	322	592	420	233	22-30	63	305	10
225	200	131608PA	250	149	322	592	420	233	22-30	63	330	10

\*C1, C2, L and L1 values may vary.

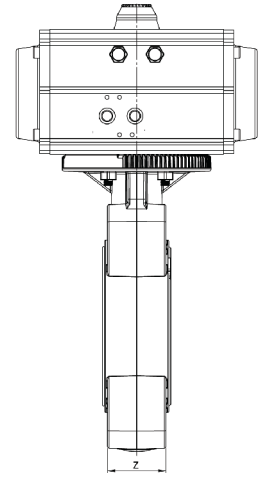
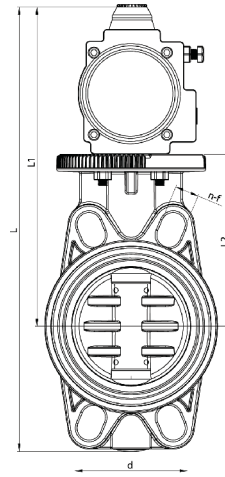
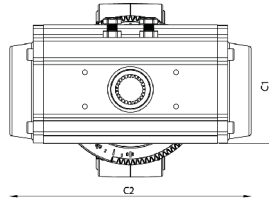

Made from extruded aluminum. Shaft from cadmium plating steel.  
Pistons from casted aluminum.  
ON/OFF position indicator.  
Quick OPEN/CLOSE compared to electric actuators.  
Valve fixation according to ISO5211.

## Pneumatic Actuated Butterfly Valve Double Acting - without Flange Set

mm	DN	Code	inch	d	C1	C2	L	L1	L2	n-F	Z	PN
63	50	131620PA2	2"	51	90	172	293	221	112	19-27	38	10
75	65	131621PA2	2½"	69	90	172	310	227	119	19-27	41	10
90	80	131622PA2	3"	78	94	188	346	254	134	19-26	44	10
110	100	131623PA2	4"	101	117	221	390	280	150	21-31	51	10
125	125	131624PA2	-	126	124	268	430	305	167	24-29	59	10
140	125	131625PA2	5"	126	124	268	430	305	167	24-29	59	10
160	150	131626PA2	6"	200	131	279	470	335	181	25-31	55	10
200	200	131627PA2	-	200	149	322	580	420	233	22-30	63	10
225	200	131628PA2	8"	250	149	322	580	420	233	22-30	63	10

\*C1, C2, L and L1 values may vary.

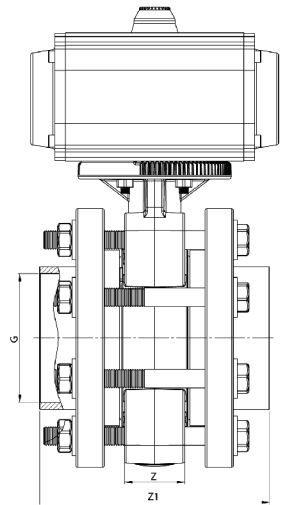
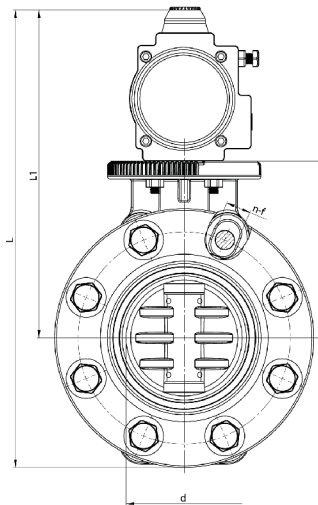
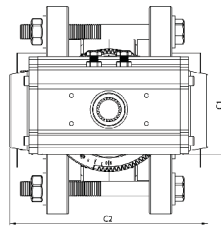

Made from extruded aluminum. Shaft from cadmium plating steel. Pistons from casted aluminum.  
Quick OPEN/CLOSE compared to electric actuators.  
Valve fixation according to ISO5211.  
Complete with flange, flange adaptor and screw set.

- SS316 screw set is optional.

## Pneumatic Actuated Butterfly Valve Double Acting - Complete with Flange Set

G	DN	Code	d	C1	C2	L	L1	L2	n-F	Z	Z1	PN
63	50	131600PA2	51	90	172	305	221	112	19-27	38	128	10
75	65	131601PA2	69	90	172	320	227	119	19-27	41	142	10
90	80	131602PA2	78	94	188	355	254	134	19-26	44	167	10
110	100	131603PA2	101	117	221	390	280	150	21-31	51	190	10
125	125	131604PA2	126	124	268	430	305	167	24-29	59	218	10
140	125	131605PA2	126	124	268	430	305	167	24-29	59	230	10
160	150	131606PA2	200	131	279	480	335	181	25-31	55	256	10
200	200	131607PA2	200	149	322	592	420	233	22-30	63	305	10
225	200	131608PA2	250	149	322	592	420	233	22-30	63	330	10

\*C1, C2, L and L1 values may vary.



# INDUSTRIAL VALVES



Body made of UPVC.  
 Handle made of ABS.  
 For highly corrosive acids;  
 Seats from PTFE. O-rings FPM.  
*\*PTFE seats & EPDM O-ring versions  
 are optional (for weaker acid solutions).*

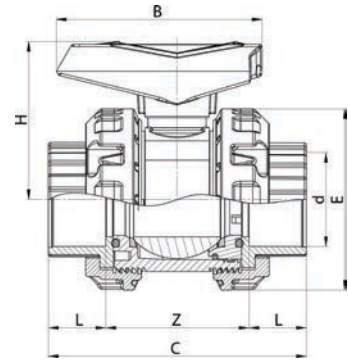

## Industrial Ball Valve for Acids

### Solvent Cement

d	DN	Code	B	H	E	L	Z	C	PN	Box
20	16	131121L	80	59	64,5	20	53	93	16	35
25	20	131122L	80	59	64,5	20	53	93	16	35
32	25	131123L	92	66	75	23,5	60	107	16	20
40	32	131124L	103	78	88	26	70	122	16	12
50	40	131125L	116	95	100	33	80	146	16	12
63	50	131126L	137	106	122	38	93	169	16	6
75	65	131127L	161	113	143	44	109	197	16	2
90	80	131128L	161	113	143	52	114	221	16	2
110	100	131129L	248	171	226	60	166	286	16	1



One side BSP Standard threads.  
 Body made of UPVC.  
 Handle made of ABS.  
 For highly corrosive acids;  
 Seats from PTFE. O-rings FPM.  
*\*PTFE seats & EPDM O-ring versions  
 are optional (for weaker acid solutions).*

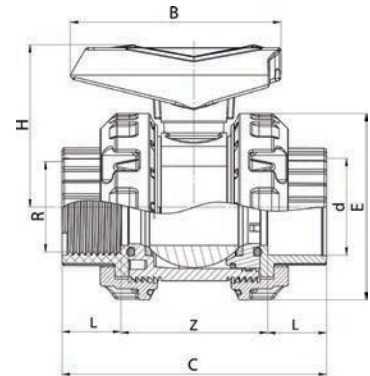

## Industrial Ball Valve for Acids

### Solvent Cement x Female Threaded

d	R	DN	Code	B	H	E	R	Z	C	PN	Box
20	1/2"	16	131121LT1	80	59	64,5	20	53	93	16	35
25	3/4"	20	131122LT1	80	59	64,5	20	53	93	16	35
32	1"	25	131123LT1	92	66	75	23,5	60	107	16	20
40	1 1/4"	32	131124LT1	103	78	88	26	70	122	16	12
50	1 1/2"	40	131125LT1	116	95	100	33	80	146	16	12
63	2"	50	131126LT1	137	106	122	38	93	169	16	6
75	2 1/2"	65	131127LT1	161	113	143	44	109	197	16	2
90	3"	80	131128LT1	161	113	143	52	114	221	16	2
110	4"	100	131129LT1	248	171	226	60	166	286	16	1



Two sides BSP Standard threads.  
 Body made of UPVC.  
 Handle made of ABS.  
 For highly corrosive acids;  
 Seats from PTFE. O-rings FPM.  
*\*PTFE seats & EPDM O-ring versions  
 are optional (for weaker acid solutions).*

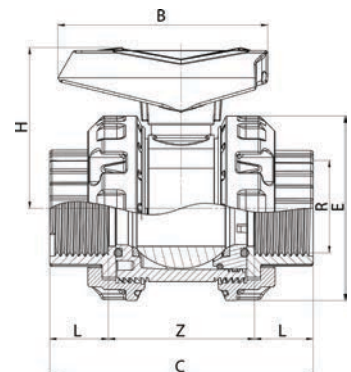

## Industrial Ball Valve for Acids

### Female Threaded x Female Threaded

R	DN	Code	B	H	E	L	Z	C	PN	Box
1/2"	16	131121LT	80	59	64,5	20	53	93	16	35
3/4"	20	131122LT	80	59	64,5	20	53	93	16	35
1"	25	131123LT	92	66	75	23,5	60	107	16	20
1 1/4"	32	131124LT	103	78	88	26	70	122	16	12
1 1/2"	40	131125LT	116	95	100	33	80	146	16	12
2"	50	131126LT	137	106	122	38	93	169	16	6
2 1/2"	65	131127LT	161	113	143	44	109	197	16	2
3"	80	131128LT	161	113	143	52	114	221	16	2
4"	100	131129LT	248	171	226	60	166	286	16	1



Actuator mounting kit made of UPVC.  
 Connections comply to ISO5211.  
 M6 screw holes for actuator connection.  
 Screws of mounting kit from SS316.  
 Seats from PTFE. O-ring from FPM.  
 \*PTFE seats & EPDM O-ring versions are optional (for weaker acid solutions).

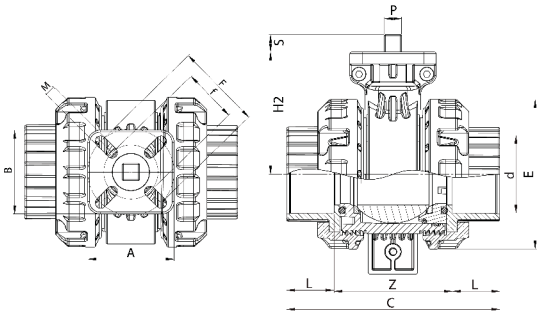

## Actuator Mountable Industrial Ball Valve Solvent Cement

d	DN	Code	A	B	C	E	H2	L	M(metric)	ISO5211	f-F	P	S	Z	PN
20	16	131121LA	52	52	93	64,5	54	20	6	F03-F05	36-50	11	14	53	16
25	20	131122LA	52	52	93	64,5	54	20	6	F03-F05	36-50	11	14	53	16
32	25	131123LA	52	52	107	75	61	23,5	6	F03-F05	36-50	11	14	60	16
40	32	131124LA	52	52	122	88	72	26	6	F03-F05	36-50	11	14	70	16
50	40	131125LA	70	68	146	100	92	33	8	F05-F07	50-70	14	17	80	16
63	50	131126LA	70	68	169	122	100	38	8	F05-F07	50-70	14	17	93	16
75	65	131127LA	70	68	197	143	107	44	8	F05-F07	50-70	14	17	109	16
90	80	131128LA	70	68	221	143	107	52	8	F05-F07	50-70	14	17	114	16
110	100	131129LA	105	105	286	226	154	60	10	F07-F10	70-102	17	19	166	16



Actuator mounting kit made of UPVC.  
 Connections comply to ISO5211.  
 M6 screw holes for actuator connection.  
 Screws of mounting kit from SS316.  
 Seats from PTFE. O-ring from FPM.  
 One side BSP Standard female threaded.  
 \*PTFE seats & EPDM O-ring versions are optional (for weaker acid solutions).

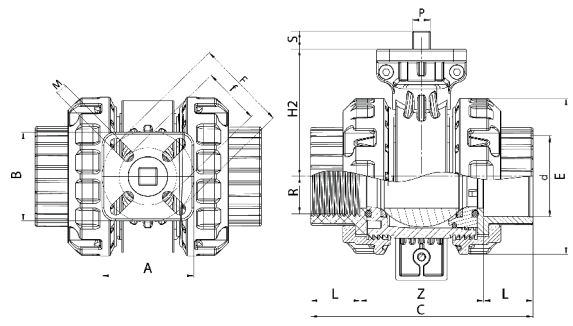

## Actuator Mountable Industrial Ball Valve Solvent Cement x Female Threaded

d	R	DN	Code	A	B	C	E	H2	L	M(metric)	ISO5211	f-F	P	S	Z	PN
20	½"	16	131121LAT1	52	52	93	64,5	54	20	6	F03-F05	36-50	11	14	53	16
25	¾"	20	131122LAT1	52	52	93	64,5	54	20	6	F03-F05	36-50	11	14	53	16
32	1"	25	131123LAT1	52	52	107	75	61	23,5	6	F03-F05	36-50	11	14	60	16
40	1¼"	32	131124LAT1	52	52	122	88	72	26	6	F03-F05	36-50	11	14	70	16
50	1½"	40	131125LAT1	70	68	146	100	92	33	8	F05-F07	50-70	14	17	80	16
63	2"	50	131126LAT1	70	68	169	122	100	38	8	F05-F07	50-70	14	17	93	16
75	2½"	65	131127LAT1	70	68	197	143	107	44	8	F05-F07	50-70	14	17	109	16
90	3"	80	131128LAT1	70	68	221	143	107	52	8	F05-F07	50-70	14	17	114	16
110	4"	100	131129LAT1	105	105	286	226	154	60	10	F07-F10	70-102	17	19	166	16



Actuator mounting kit made of UPVC.  
 Connections comply to ISO5211.  
 M6 screw holes for actuator connection.  
 Screws of mounting kit from SS316.  
 Seats from PTFE. O-ring from FPM.  
 Two sides BSP Standard female threaded.  
 \*PTFE seats & EPDM O-ring versions are optional (for weaker acid solutions).

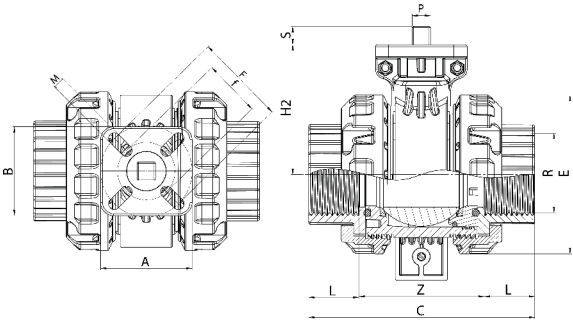

## Actuator Mountable Industrial Ball Valve Female Threaded x Female Threaded

R	DN	Code	A	B	C	E	H2	L	M(metric)	ISO5211	f-F	P	S	Z	PN
½"	16	131121LAT	52	52	93	64,5	54	20	6	F03-F05	36-50	11	14	53	16
¾"	20	131122LAT	52	52	93	64,5	54	20	6	F03-F05	36-50	11	14	53	16
1"	25	131123LAT	52	52	107	75	61	23,5	6	F03-F05	36-50	11	14	60	16
1¼"	32	131124LAT	52	52	122	88	72	26	6	F03-F05	36-50	11	14	70	16
1½"	40	131125LAT	70	68	146	100	92	33	8	F05-F07	50-70	14	14	80	16
2"	50	131126LAT	70	68	169	122	100	38	8	F05-F07	50-70	14	14	93	16
2½"	65	131127LAT	70	68	197	143	107	44	8	F05-F07	50-70	14	14	109	16
3"	80	131128LAT	70	68	221	143	107	52	8	F05-F07	50-70	14	14	114	16
4"	100	131129LAT	105	105	286	226	154	60	10	F07-F10	70-102	17	14	166	16



Valve seats PTFE.O-rings FPM.  
 Noncorrosive thermoplastic body.  
 0° - 90° working angle.  
 ON/OFF position indicator.  
 Manual control with wrench.  
 Internal thread protection. IP67.  
 Connection screws SS316.  
 \*PTFE seats & EPDM O-ring versions  
 are optional (for weaker acid solutions).

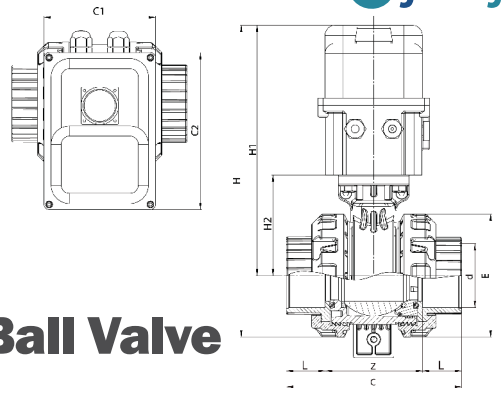

**Electric Actuated Industrial Ball Valve**  
 Solvent Cement - 24V DC ON/OFF

d	DN	Code	C	C1	C2	E	H	H1	H2	L	Z	PN
20	16	131121LEA	93	96	137	64,5	214	182	54	20	53	16
25	20	131122LEA	93	96	137	64,5	214	182	54	20	53	16
32	25	131123LEA	107	96	137	75	228	190	61	23,5	60	16
40	32	131124LEA	122	96	137	88	241	197	72	26	70	16
50	40	131125LEA	146	110	155	100	289	239	92	33	80	16
63	50	131126LEA	169	110	155	122	309	248	100	38	93	16
75	65	131127LEA	197	110	155	143	333	262	107	44	109	16
90	80	131128LEA	221	110	155	143	333	262	107	52	114	16
110	100	131129LEA	286	110	155	226	415	309	154	60	166	16



Valve seats PTFE.O-rings FPM.  
 Noncorrosive thermoplastic body.  
 0° - 90° working angle.  
 ON/OFF position indicator.  
 Manual control with wrench.  
 Internal thread protection. IP67.  
 Connection screws SS316.  
 One side BSP Standard female threaded.  
 \*PTFE seats & EPDM O-ring versions  
 are optional (for weaker acid solutions).

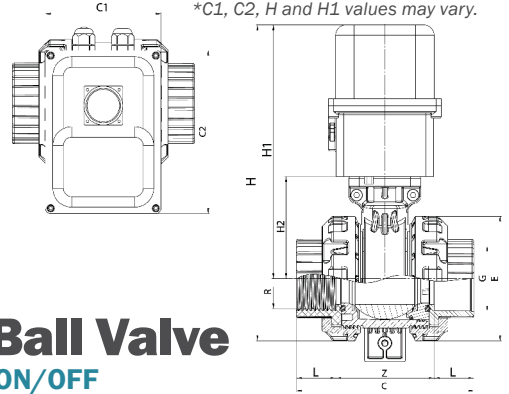

**Electric Actuated Industrial Ball Valve**  
 Solvent Cement x Female Threaded - 24V DC ON/OFF

d	R	DN	Code	C	C1	C2	E	H	H1	H2	L	Z	PN
20	½"	16	131121LEAT1	93	96	137	64,5	214	182	54	20	53	16
25	¾"	20	131122LEAT1	93	96	137	64,5	214	182	54	20	53	16
32	1"	25	131123LEAT1	107	96	137	75	228	190	61	23,5	60	16
40	1¼"	32	131124LEAT1	122	96	137	88	241	197	72	26	70	16
50	1½"	40	131125LEAT1	146	110	155	100	289	239	92	33	80	16
63	2"	50	131126LEAT1	169	110	155	122	309	248	100	38	93	16
75	2½"	65	131127LEAT1	197	110	155	143	333	262	107	44	109	16
90	3"	80	131128LEAT1	221	110	155	143	333	262	107	52	114	16
110	4"	100	131129LEAT1	286	110	155	226	415	309	154	60	166	16



Valve seats PTFE.O-rings FPM.  
 Noncorrosive thermoplastic body.  
 0° - 90° working angle.  
 ON/OFF position indicator.  
 Manual control with wrench.  
 Internal thread protection. IP67.  
 Connection screws SS316.  
 Two sides BSP Standard female threaded.  
 \*PTFE seats & EPDM O-ring versions  
 are optional (for weaker acid solutions).

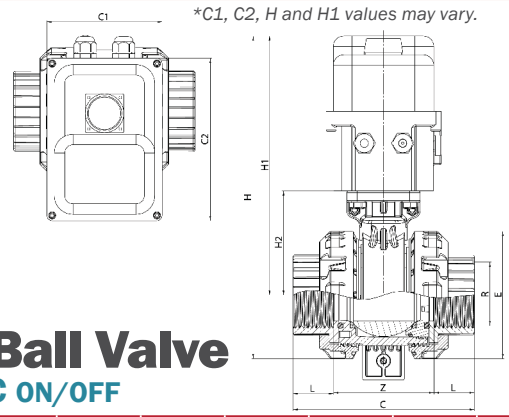

**Electric Actuated Industrial Ball Valve**  
 Female Threaded x Female Threaded - 24V DC ON/OFF

R	DN	Code	C	C1	C2	E	H	H1	H2	L	Z	PN
½"	16	131121LEAT	93	96	137	64,5	214	182	54	20	53	16
¾"	20	131122LEAT	93	96	137	64,5	214	182	54	20	53	16
1"	25	131123LEAT	107	96	137	75	228	190	61	23,5	60	16
1¼"	32	131124LEAT	122	96	137	88	241	197	72	26	70	16
1½"	40	131125LEAT	146	110	155	100	289	239	92	33	80	16
2"	50	131126LEAT	169	110	155	122	309	248	100	38	93	16
2½"	65	131127LEAT	197	110	155	143	333	262	107	44	109	16
3"	80	131128LEAT	221	110	155	143	333	262	107	52	114	16
4"	100	131129LEAT	286	110	155	226	415	309	154	60	166	16

\*C1, C2, H and H1 values may vary.



Valve seats PTFE. O-rings FPM.  
 Made from extruded aluminum. Shaft from cadmium plating steel. Pistons from casted aluminum.  
 ON/OFF position indicator.  
 Quick OPEN/CLOSE compared to electric actuators.  
 Valve fixation according to ISO5211.  
 Connection screws SS316.

*\*PTFE seats & EPDM O-ring versions are optional (for weaker acid solutions).*

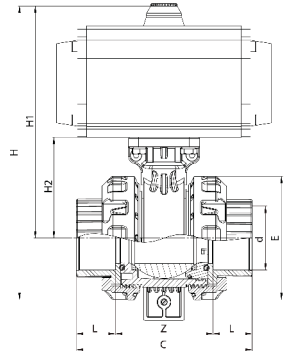
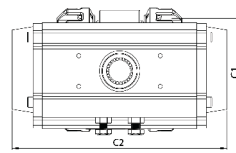

## Pneumatic Actuated Industrial Ball Valve

### Solvent Cement - Single Acting

d	DN	Code	C	C1	C2	E	H	H1	H2	L	Z	PN
20	16	131121LPA1	93	80	150	64,5	184	152	54	20	53	16
25	20	131122LPA1	93	80	150	64,5	184	152	54	20	53	16
32	25	131123LPA1	107	80	150	75	197	160	61	23,5	60	16
40	32	131124LPA1	122	80	150	88	211	167	72	26	70	16
50	40	131125LPA1	146	94	188	100	261	211	92	33	80	16
63	50	131126LPA1	169	94	188	122	281	220	100	38	93	16
75	65	131127LPA1	197	124	268	143	315	244	107	44	109	16
90	80	131128LPA1	221	124	268	143	315	244	107	52	114	16
110	100	131129LPA1	286	149	322	226	450	337	154	60	166	16

*\*C1, C2, H and H1 values may vary.*



Valve seats PTFE. O-rings FPM.  
 Made from extruded aluminum. Shaft from cadmium plating steel. Pistons from casted aluminum.  
 ON/OFF position indicator.  
 Quick OPEN/CLOSE compared to electric actuators.  
 Valve fixation according to ISO5211.  
 Connection screws SS316.

One side BSP female threaded.

*\*PTFE seats & EPDM O-ring versions are optional (for weaker acid solutions).*

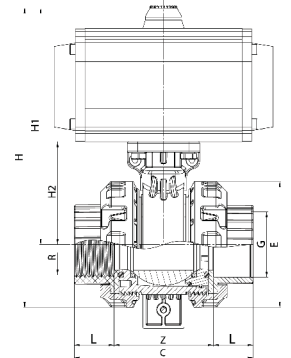
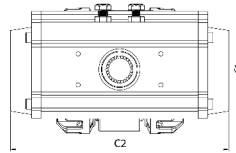

## Pneumatic Actuated Industrial Ball Valve

### Solvent Cement x Female Threaded - Single Acting

d	R	DN	Code	C	C1	C2	E	H	H1	H2	L	Z	PN
20	1/2"	16	131121LPA1T1	93	80	150	64,5	184	152	54	20	53	16
25	3/4"	20	131122LPA1T1	93	80	150	64,5	184	152	54	20	53	16
32	1"	25	131123LPA1T1	107	80	150	75	197	160	61	23,5	60	16
40	1 1/4"	32	131124LPA1T1	122	80	150	88	211	167	72	26	70	16
50	1 1/2"	40	131125LPA1T1	146	94	188	100	261	211	92	33	80	16
63	2"	50	131126LPA1T1	169	94	188	122	281	220	100	38	93	16
75	2 1/2"	65	131127LPA1T1	197	124	268	143	315	244	107	44	109	16
90	3"	80	131128LPA1T1	221	124	268	143	315	244	107	52	114	16
110	4"	100	131129LPA1T1	286	149	322	226	450	337	154	60	166	16

*\*C1, C2, H and H1 values may vary.*



Valve seats PTFE. O-rings FPM.  
 Made from extruded aluminum. Shaft from cadmium plating steel. Pistons from casted aluminum.  
 ON/OFF position indicator.  
 Quick OPEN/CLOSE compared to electric actuators.  
 Valve fixation according to ISO5211.  
 Connection screws SS316.

Two sides BSP female threaded.

*\*PTFE seats & EPDM O-ring versions are optional (for weaker acid solutions).*

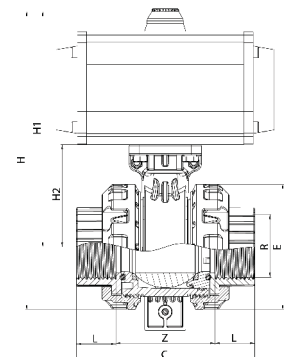
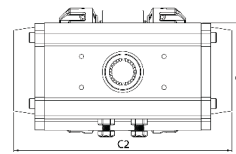

## Pneumatic Actuated Industrial Ball Valve

### Female Threaded x Female Threaded - Single Acting

R	DN	Code	C	C1	C2	E	H	H1	H2	L	Z	PN
1/2"	16	131121LPA1T	93	80	150	64,5	184	152	54	20	53	16
3/4"	20	131122LPA1T	93	80	150	64,5	184	152	54	20	53	16
1"	25	131123LPA1T	107	80	150	75	197	160	61	23,5	60	16
1 1/4"	32	131124LPA1T	122	80	150	88	211	167	72	26	70	16
1 1/2"	40	131125LPA1T	146	94	188	100	261	211	92	33	80	16
2"	50	131126LPA1T	169	94	188	122	281	220	100	38	93	16
2 1/2"	65	131127LPA1T	197	124	268	143	315	244	107	44	109	16
3"	80	131128LPA1T	221	124	268	143	315	244	107	52	114	16
4"	100	131129LPA1T	286	149	322	226	450	337	154	60	166	16

*\*C1, C2, H and H1 values may vary.*



**NEW PRODUCT**

Valve seats PTFE. O-rings FPM.  
 Made from extruded aluminum. Shaft from cadmium plating steel. Pistons from casted aluminum.  
 ON/OFF position indicator.  
 Quick OPEN/CLOSE compared to electric actuators.  
 Valve fixation according to ISO5211.  
 Connection screws SS316.

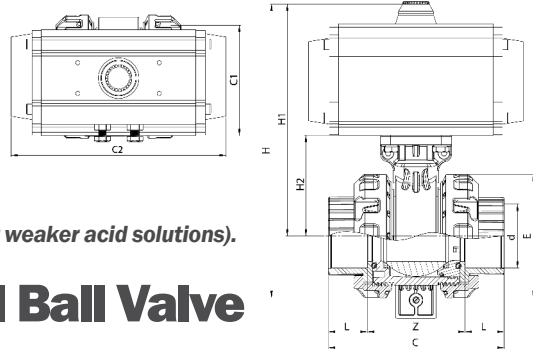

*\*PTFE seats & EPDM O-ring versions are optional (for weaker acid solutions).*

## Pneumatic Actuated Industrial Ball Valve Solvent Cement - Double Acting

d	DN	Code	C	C1	C2	E	H	H1	H2	L	Z	PN
20	16	131121LPA2	93	80	150	64,5	184	152	54	20	53	16
25	20	131122LPA2	93	80	150	64,5	184	152	54	20	53	16
32	25	131123LPA2	107	80	150	75	197	160	61	23,5	60	16
40	32	131124LPA2	122	80	150	88	211	167	72	26	70	16
50	40	131125LPA2	146	94	188	100	261	211	92	33	80	16
63	50	131126LPA2	169	94	188	122	281	220	100	38	93	16
75	65	131127LPA2	197	124	268	143	315	244	107	44	109	16
90	80	131128LPA2	221	124	268	143	315	244	107	52	114	16
110	100	131129LPA2	286	149	322	226	450	337	154	60	166	16

*\*C1, C2, H and H1 values may vary.*



**NEW PRODUCT**

Valve seats PTFE. O-rings FPM.  
 Made from extruded aluminum. Shaft from cadmium plating steel. Pistons from casted aluminum.  
 ON/OFF position indicator.  
 Quick OPEN/CLOSE compared to electric actuators.  
 Valve fixation according to ISO5211.  
 Connection screws SS316.

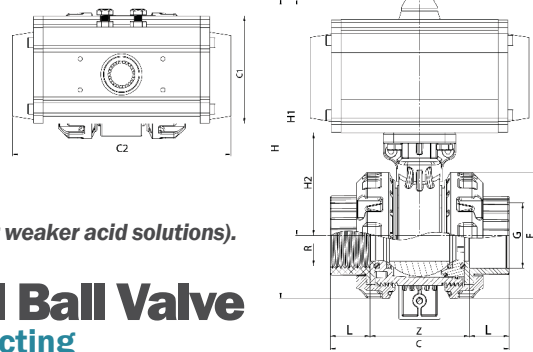

One side BSP female threaded.

*\*PTFE seats & EPDM O-ring versions are optional (for weaker acid solutions).*

## Pneumatic Actuated Industrial Ball Valve Solvent Cement x Female Threaded - Double Acting

d	R	DN	Code	C	C1	C2	E	H	H1	H2	L	Z	PN
20	½"	16	131121LPA2T1	93	80	150	64,5	184	152	54	20	53	16
25	¾"	20	131122LPA2T1	93	80	150	64,5	184	152	54	20	53	16
32	1"	25	131123LPA2T1	107	80	150	75	197	160	61	23,5	60	16
40	1¼"	32	131124LPA2T1	122	80	150	88	211	167	72	26	70	16
50	1½"	40	131125LPA2T1	146	94	188	100	261	211	92	33	80	16
63	2"	50	131126LPA2T1	169	94	188	122	281	220	100	38	93	16
75	2½"	65	131127LPA2T1	197	124	268	143	315	244	107	44	109	16
90	3"	80	131128LPA2T1	221	124	268	143	315	244	107	52	114	16
110	4"	100	131129LPA2T1	286	149	322	226	450	337	154	60	166	16

*\*C1, C2, H and H1 values may vary.*



**NEW PRODUCT**

Valve seats PTFE. O-rings FPM.  
 Made from extruded aluminum. Shaft from cadmium plating steel. Pistons from casted aluminum.  
 ON/OFF position indicator.  
 Quick OPEN/CLOSE compared to electric actuators.  
 Valve fixation according to ISO5211.  
 Connection screws SS316.

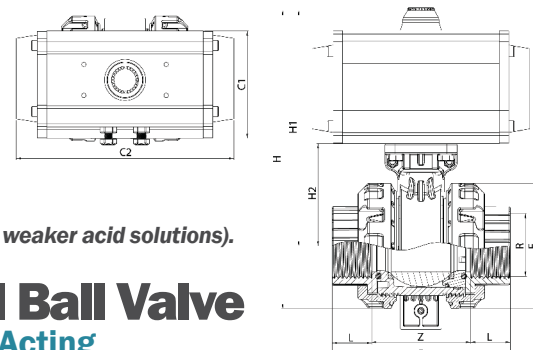

Two sides BSP female threaded.

*\*PTFE seats & EPDM O-ring versions are optional (for weaker acid solutions).*

## Pneumatic Actuated Industrial Ball Valve Female Threaded x Female Threaded - Double Acting

R	DN	Code	C	C1	C2	E	H	H1	H2	L	Z	PN
½"	16	131121LPA2T	93	80	150	64,5	184	152	54	20	53	16
¾"	20	131122LPA2T	93	80	150	64,5	184	152	54	20	53	16
1"	25	131123LPA2T	107	80	150	75	197	160	61	23,5	60	16
1¼"	32	131124LPA2T	122	80	150	88	211	167	72	26	70	16
1½"	40	131125LPA2T	146	94	188	100	261	211	92	33	80	16
2"	50	131126LPA2T	169	94	188	122	281	220	100	38	93	16
2½"	65	131127LPA2T	197	124	268	143	315	244	107	44	109	16
3"	80	131128LPA2T	221	124	268	143	315	244	107	52	114	16
4"	100	131129LPA2T	286	149	322	226	450	337	154	60	166	16

*\*C1, C2, H and H1 values may vary.*



**NEW PRODUCT**

Body made of UPVC. Handle made of ABS.  
For highly corrosive acids; Seats from PTFE. O-rings FPM.  
Connection with loose flange DIN8063.  
*\*PTFE seats & EPDM O-ring versions are optional (for weaker acid solutions).*

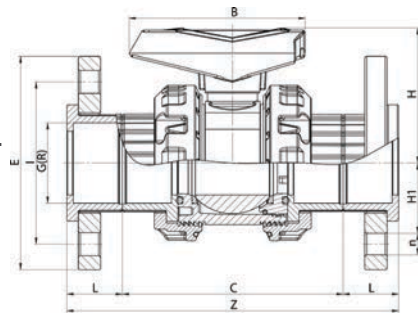

## Industrial Ball Valve for Acids

### Both Sides Flange Connection

G	DN	inch	Code	B	H	E	I	L	Z	C	H1	n	PN
50	40	1½"	131125LF	116	95	151	110	38	222	146	46	18	16
63	50	2"	131126LF	137	106	167	127	42,5	254	169	54,5	18	16
75	65	2½"	131127LF	161	113	186	145	47	291	197	63,5	18	16
90	80	3"	131128LF	161	113	202	163	58	337	221	72	20	16
110	100	4"	131129LF	248	171	222	182	65	416	286	82	18	16

\*C1, C2, H and H1 values may vary.



**NEW PRODUCT**

Actuator mounting kit made of UPVC.  
Connections comply to ISO5211.  
M6 screw holes for actuator connection.  
Connection with loose flange DIN 8063.  
For highly corrosive acids; Seats from PTFE. O-rings FPM.  
*\*PTFE seats & EPDM O-ring versions are optional (for weaker acid solutions).*

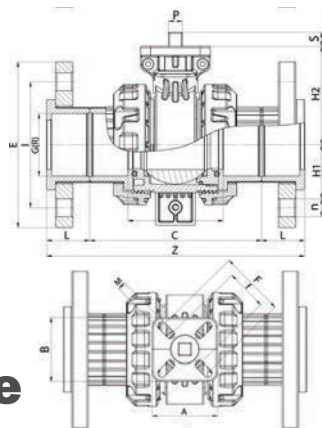

## Actuator Mountable Industrial Ball Valve

### Both Side Flange Connection

G	DN	inch	Code	A	B	C	E	I	H1	H2	M(metric)	ISO5211	f-F	P	S	L	Z	n	PN
50	40	1½"	131125LAF	70	68	146	151	110	46	92	8	F05 - F07	50-70	14	17	38	222	18	16
63	50	2"	131126LAF	70	68	169	167	127	54,5	100	8	F05 - F07	50-70	14	17	42,5	254	18	16
75	65	2½"	131127LAF	70	68	197	186	145	63,5	107	8	F05 - F07	50-70	14	17	47	291	18	16
90	80	3"	131128LAF	70	68	221	202	163	72	107	8	F05 - F07	50-70	14	17	58	337	20	16
110	100	4"	131129LAF	105	105	286	222	182	82	154	10	F07 - F010	70-100	17	19	65	416	18	16

\*C1, C2, H and H1 values may vary.



**NEW PRODUCT**

Noncorrosive thermoplastic body.  
0-90° working angle.  
ON/OFF position indicator.  
Manual control with wrench.  
Internal thread protection. IP67.  
Connection with loose flange DIN 8063.

*\*PTFE seats & EPDM O-ring versions are optional (for weaker acid solutions).*

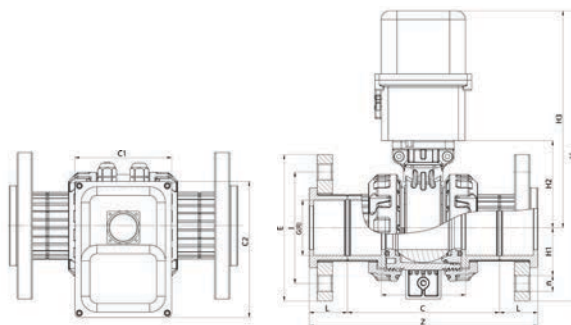

## Electric Actuated Industrial Ball Valve

### Both Side Flange Connection - 24VDC

G	DN	inch	Code	C	C1	C2	E	I	H1	H2	H3	H	L	Z	n	PN
50	40	1½"	131125LEAF	146	110	155	151	110	46	92	239	314	38	222	18	16
63	50	2"	131126LEAF	169	110	155	167	127	54,5	100	248	332	42,5	254	18	16
75	65	2½"	131127LEAF	197	110	155	186	145	63,5	107	255	348	47	291	18	16
90	80	3"	131128LEAF	221	110	155	202	163	72	107	255	356	58	337	20	16
110	100	4"	131129LEAF	286	110	155	222	182	82	154	309	420	65	416	18	16

\*C1, C2, H and H1 values may vary.



Valve seats **PTFE**. O-rings **FPM**.  
 Actuator body made from extruded aluminum. Shaft from cadmium plating steel.  
 Pistons from casted aluminum.  
**ON/OFF** position indicator.  
 Quick **OPEN/CLOSE** compared to electric actuators.  
 Valve fixation according to **ISO5211**.  
 Connection with loose flange **DIN 8063**.  
*\*PTFE seats & EPDM O-ring versions are optional (for weaker acid solutions).*

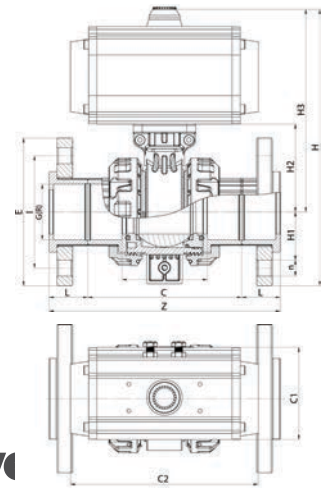

## Pneumatic Actuated Industrial Ball Valve Both Side Flange Connection - Single Acting

G	DN	inch	Code	C	C1	C2	E	I	H1	H2	H3	H	L	Z	n	PN
50	40	1½"	131125LPA1F	146	94	188	151	110	46	91	211	286	38	222	18	16
63	50	2"	131126LPA1F	169	94	188	167	127	54,5	100	220	304	42,5	254	18	16
75	65	2½"	131127LPA1F	197	124	268	186	145	63,5	107	244	337	47	291	18	16
90	80	3"	131128LPA1F	221	124	268	202	163	72	107	244	345	58	337	20	16
110	100	4"	131129LPA1F	286	149	322	222	182	82	151	337	448	65	416	18	16

*\*C1, C2, H and H1 values may vary.*



Valve seats **PTFE**. O-rings **FPM**.  
 Actuator body made from extruded aluminum. Shaft from cadmium plating steel.  
 Pistons from casted aluminum.  
**ON/OFF** position indicator.  
 Quick **OPEN/CLOSE** compared to electric actuators.  
 Valve fixation according to **ISO5211**.  
 Connection with loose flange **DIN 8063**.  
*\*PTFE seats & EPDM O-ring versions are optional (for weaker acid solutions).*

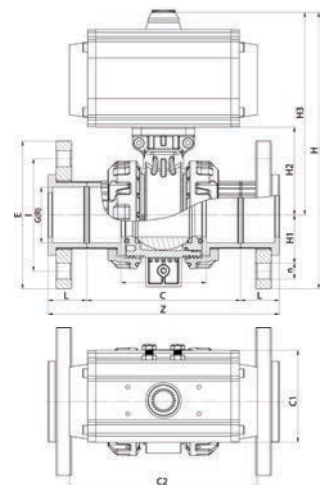

## Pneumatic Actuated Industrial Ball Valve Both Side Flange Connection - Double Acting

G	DN	inch	Code	C	C1	C2	E	I	H1	H2	H3	H	L	Z	n	PN
50	40	1½"	131125LPA2F	146	94	188	151	110	46	91	211	286	38	222	18	16
63	50	2"	131126LPA2F	169	94	188	167	127	54,5	100	220	304	42,5	254	18	16
75	65	2½"	131127LPA2F	197	124	268	186	145	63,5	107	244	337	47	291	18	16
90	80	3"	131128LPA2F	221	124	268	202	163	72	107	244	345	58	337	20	16
110	100	4"	131129LPA2F	286	149	322	222	182	82	151	337	448	65	416	18	16

*\*C1, C2, H and H1 values may vary.*



Enhanced ergonomic grip.  
 Handle from ABS.  
 The valve can be positioned in desired angle by the help of handle clutches.  
 Shaft made of SS304.  
 Liner from FPM.  
 Security padlock hole.

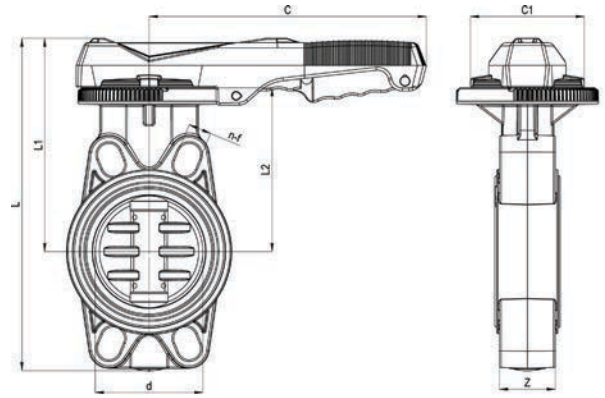

## Industrial Butterfly Valve without Flange Set

- SS316 shaft is optional

mm	DN	inch	Code	d	C	C1	L	L1	L2	n-F	Z	PN	Box
63	50	2"	131680	51	185	73	220	147	112	19-27	38	10	1
75	65	2½"	131681	69	209	86	239	158	119	19-27	41	10	1
90	80	3"	131682	78	209	86	264	172	134	19-26	44	10	1
110	100	4"	131683	101	255	105	307	195	150	21-31	51	10	1
125	110	-	131684	126	255	105	340	215	167	24-29	59	10	1
140	125	5"	131685	126	255	105	340	215	167	24-29	59	10	1
160	150	6"	131686	146	310	105	365	228	181	25-31	65	10	1
200	200	-	131687	200	335	119	452	290	233	22-30	63	10	1
225	200	8"	131688	200	335	119	452	290	233	22-30	63	10	1
250	250	10"	131689	250	310	155	450	325	165	10-25	100	10	1
280	250	-	131690	280	310	155	480	340	195	10-25	110	10	1
315	300	12"	131691	300	320	155	500	350	215	10-25	120	10	1



Enhanced ergonomic grip.  
 Handle from ABS.  
 The valve can be positioned in desired angle by the help of handle clutches.  
 Shaft made of SS304.  
 Liner from FPM.  
 Security padlock hole.  
 Complete with flanges, bolts and screw set.  
 Screw set from SS316.

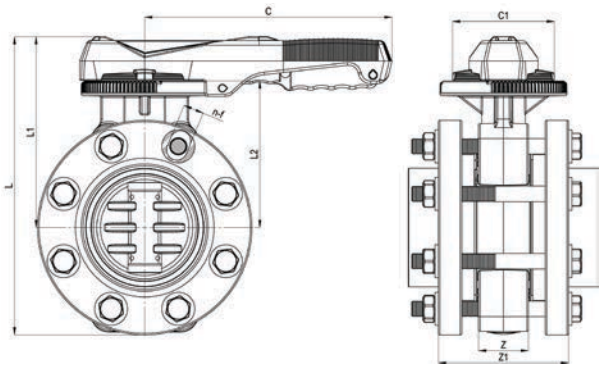

## Industrial Butterfly Valve Complete with Flange Set

- SS316 shaft is optional

mm	DN	Code	d	C	C1	L	L1	L2	n-F	Z	Z1	PN	Box
63	50	131700	51	185	72	220	147	112	19-27	38	128	10	1
75	65	131701	69	209	86	239	158	119	19-27	41	142	10	1
90	80	131702	78	209	86	264	172	134	19-26	44	167	10	1
110	100	131703	101	255	105	307	195	150	21-31	51	190	10	1
125	110	131704	126	255	105	340	215	167	24-29	59	218	10	1
140	125	131705	126	255	105	340	215	167	24-29	59	230	10	1
160	150	131706	146	255	105	365	228	181	25-31	65	256	10	1
200	175	131707	200	335	119	452	290	233	22-30	63	305	10	1
225	200	131708	200	335	119	452	290	233	22-30	63	330	10	1
250	250	131709	250	310	155	450	325	165	10-25	100	395	10	1
280	250	131710	280	310	155	480	340	195	10-25	110	440	10	1
315	315	131711	300	320	155	500	350	215	10-25	120	490	10	1

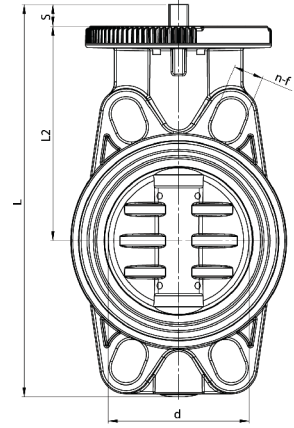
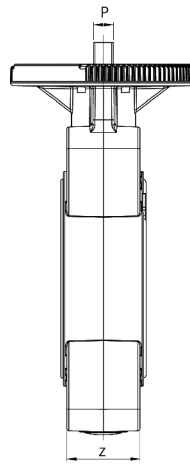
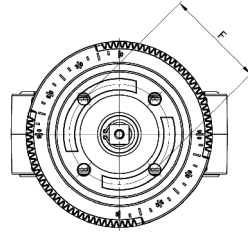

Shaft made of SS304.  
Lining from FPM.  
Butterfly valve according to ISO5211 actuator connection.  
Please check technical table for correct torque in NM.

- SS316 shaft is optional



## Industrial Butterfly Valve for Actuator Usage without Flange Set

mm	DN	inch	Code	d	ISO5211	F	L	L2	P	S	n-f	Z	PN	NM
63	50	2"	131680A	51	F5	50	196	112	9	11	19-27	38	10	30
75	65	2½"	131681A	69	F5	50	218	119	11	16	19-27	41	10	50
90	80	3"	131682A	78	F7	70	243	134	11	16	19-26	44	10	80
110	100	4"	131683A	101	F7	70	276	150	14	16	21-31	51	10	100
125	125	-	131684A	126	F7	70	308	167	14	16	24-29	59	10	100
140	125	5"	131685A	126	F7	70	308	167	14	16	24-29	59	10	100
160	150	6"	131686A	200	F7	70	332	181	14	16	25-31	55	10	140
200	200	-	131687A	200	F10	102	417	233	22	22	22-30	63	10	200
225	200	8"	131688A	250	F10	102	417	233	22	22	22-30	63	10	200

\*NM value represents the needed torque value of the selected actuator.

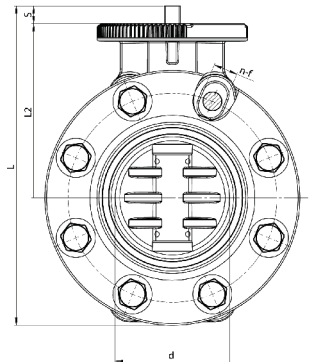
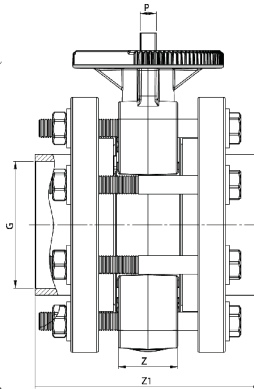
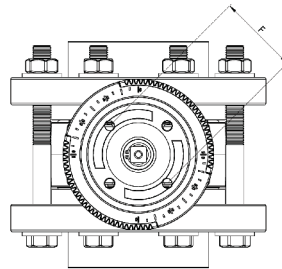

Shaft made of SS304.  
Lining from FPM.  
Butterfly valve according to ISO5211 actuator connection.  
Complete with flange, flange adaptor and nuts.  
Screw set from SS316.

- SS316 shaft is optional

Please check technical table for correct torque in NM.



## Industrial Butterfly Valve for Actuator Usage Complete with Flange Set

mm	DN	Code	d	ISO5211	F	L	L2	P	S	n-f	Z	Z1	PN	NM
63	50	131700A	51	F5	50	207	112	9	11	19-27	38	128	10	30
75	65	131701A	69	F5	50	229	119	11	16	19-27	41	142	10	50
90	80	131702A	78	F7	70	252	134	11	16	19-26	44	167	10	80
110	100	131703A	101	F7	70	276	150	14	16	21-31	51	190	10	100
125	125	131704A	126	F7	70	308	167	14	16	24-29	59	218	10	100
140	125	131705A	126	F7	70	308	167	14	16	24-29	59	230	10	100
160	150	131706A	200	F7	70	339	181	14	16	25-31	55	256	10	140
200	200	131707A	200	F10	102	426	233	22	22	22-30	63	305	10	200
225	200	131708A	250	F10	102	426	233	22	22	22-30	63	330	10	200

\*NM value represents the needed torque value of the selected actuator.

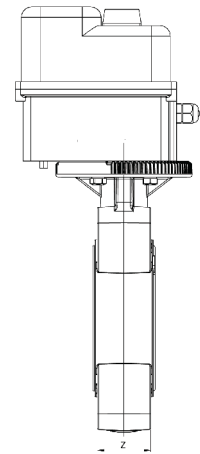
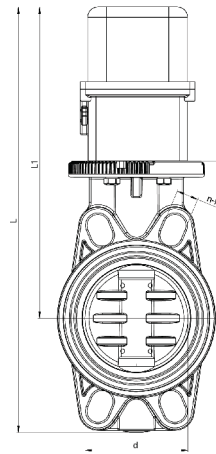
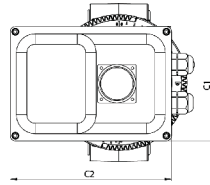

Shaft made of SS304.  
 Lining from FPM.  
 Noncorrosive thermoplastic actuator body.  
 0°- 90° working angle.  
 ON/OFF position indicator.  
 Manual control with wrench.  
 Internal thermal protection. IP67.

- SS316 shaft is optional



## Electric Actuated Industrial Butterfly Valve without Flange Set - 24 VDC ON/OFF

mm	DN	inch	Code	d	C1	C2	L	L1	L2	n-F	Z	PN
63	50	2"	131680M11	51	110	155	333	260	112	19-27	38	10
75	65	2½"	131681M11	69	110	155	350	267	119	19-27	41	10
90	80	3"	131682M11	78	110	155	375	282	134	19-26	44	10
110	100	4"	131683M11	101	110	155	415	305	150	21-31	51	10
125	110	-	131684M11	126	110	155	447	322	167	24-29	59	10
140	125	5"	131685M11	126	110	155	447	322	167	24-29	59	10
160	150	6"	131686M11	200	110	155	470	336	181	25-31	55	10
200	175	-	131687M11	200	110	155	550	386	233	22-30	63	10
225	200	8"	131688M11	250	110	155	550	386	233	22-30	63	10

\*C1, C2, L and L1 values may vary.

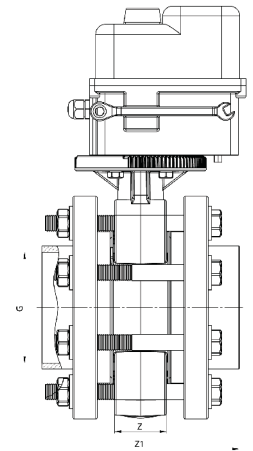
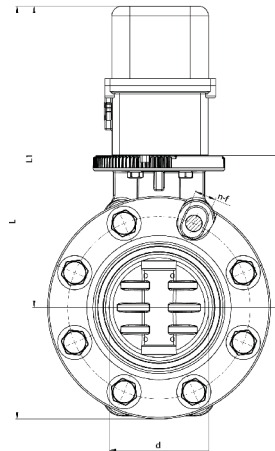
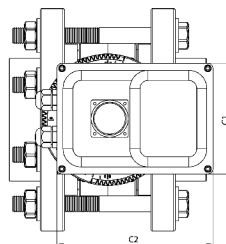

Shaft made of SS304.  
 Lining from FPM.  
 Noncorrosive thermoplastic actuator body.  
 0°- 90° working angle.  
 ON/OFF position indicator.  
 Manual control with wrench.  
 Internal thermal protection. IP67.  
 Screw set from SS316.

- SS316 shaft is optional



## Electric Actuated Industrial Butterfly Valve Complete Flange Set - 24 VDC ON/OFF

G	DN	Code	d	C1	C2	L	L1	L2	n-F	Z	Z1	PN
63	50	131700M11	51	110	155	345	260	112	19-27	38	128	10
75	65	131701M11	69	110	155	360	267	119	19-27	41	142	10
90	80	131702M11	78	110	155	383	282	134	19-26	44	167	10
110	100	131703M11	101	110	155	415	305	150	21-31	51	190	10
125	110	131704M11	126	110	155	447	322	167	24-29	59	218	10
140	125	131705M11	126	110	155	447	322	167	24-29	59	230	10
160	150	131706M11	200	110	155	478	336	181	25-31	55	256	10
200	175	131707M11	200	110	155	560	386	233	22-30	63	305	10
225	200	131708M11	250	110	155	560	386	233	22-30	63	330	10

\*C1, C2, L and L1 values may vary.

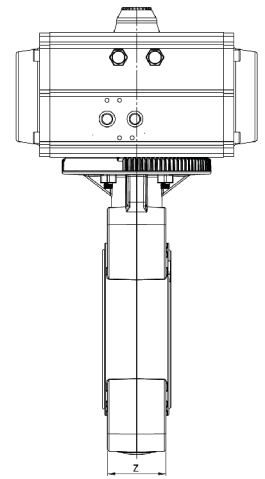
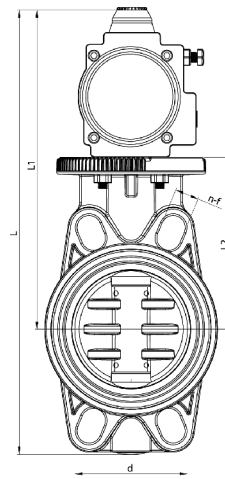
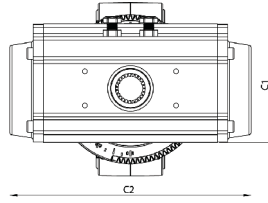

Shaft made of SS304.  
 Made from extruded aluminum.  
 Shaft from cadmium plating steel.  
 Pistons from casted aluminum.  
 Quick OPEN/CLOSE compared to electric actuators.  
 Valve fixation according to ISO5211.

- SS316 shaft is optional



## Pneumatic Actuated Industrial Butterfly Valve Single Acting - without Flange

mm	DN	Code	inch	d	C1	C2	L	L1	L2	n-F	Z	PN
63	50	131680PA	2"	51	90	172	293	221	112	19-27	38	10
75	65	131681PA	2½"	69	90	172	310	227	119	19-27	41	10
90	80	131682PA	3"	78	94	188	346	254	134	19-26	44	10
110	100	131683PA	4"	101	117	221	390	280	150	21-31	51	10
125	110	131684PA	-	126	124	268	430	305	167	24-29	59	10
140	125	131685PA	5"	126	124	268	430	305	167	24-29	59	10
160	150	131686PA	6"	200	131	279	470	335	181	25-31	55	10
200	175	131687PA	-	200	149	322	580	420	233	22-30	63	10
225	200	131688PA	8"	250	149	322	580	420	233	22-30	63	10

\*C1, C2, L and L1 values may vary.

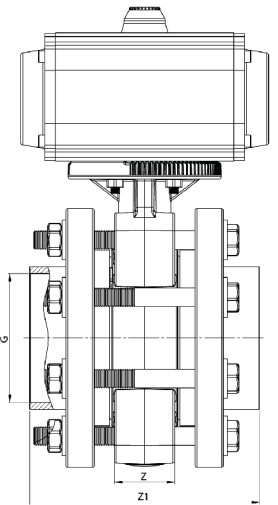
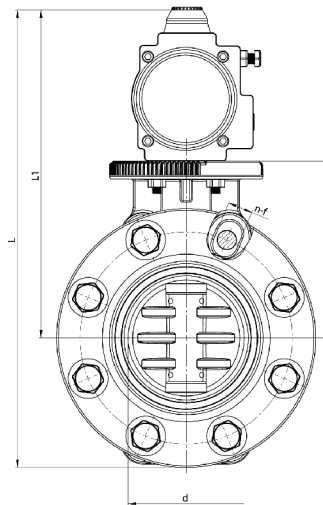
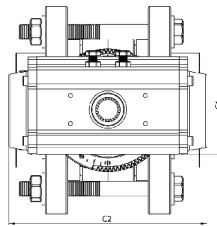

Shaft made of SS304.  
 Made from extruded aluminum.  
 Shaft from cadmium plating steel.  
 Pistons from casted aluminum.  
 Quick OPEN/CLOSE compared to electric actuators.  
 Valve fixation according to ISO5211.  
 Complete with flange, flange adaptor and nuts.  
 Screw set from SS316

- SS316 shaft is optional



## Pneumatic Actuated Industrial Butterfly Valve Single Acting - Complete with Flange Set

G	DN	Code	d	C1	C2	L	L1	L2	n-F	Z	Z1	PN
63	50	131700PA	51	90	172	305	221	112	19-27	38	128	10
75	65	131701PA	69	90	172	320	227	119	19-27	41	142	10
90	80	131702PA	78	94	188	355	254	134	19-26	44	167	10
110	100	131703PA	101	117	221	390	280	150	21-31	51	190	10
125	110	131704PA	126	124	268	430	305	167	24-29	59	218	10
140	125	131705PA	126	124	268	430	305	167	24-29	59	230	10
160	150	131706PA	200	131	279	480	335	181	25-31	55	256	10
200	175	131707PA	200	149	322	592	420	233	22-30	63	305	10
225	200	131708PA	250	149	322	592	420	233	22-30	63	330	10

\*C1, C2, L and L1 values may vary.



**NEW PRODUCT**

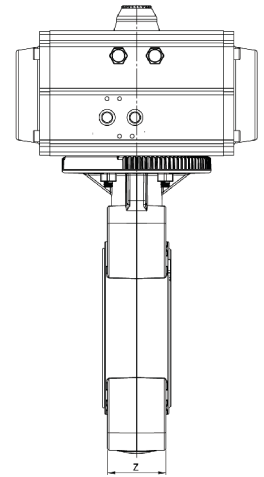
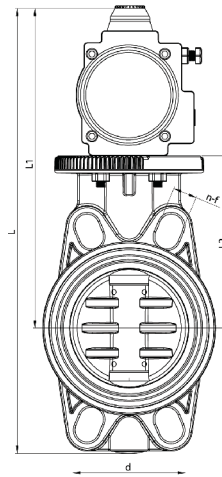
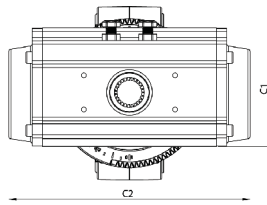

Made from extruded aluminum.  
 Shaft from cadmium plating steel.  
 Pistons from casted aluminum.  
 Quick OPEN/CLOSE compared to electric actuators.  
 Valve fixation according to ISO5211.  
 Shaft made of SS304.  
 Liner from FPM.

- SS316 shaft is optional

## Pneumatic Actuated Industrial Butterfly Valve Double Acting - without Flange

mm	DN	Code	inch	d	C1	C2	L	L1	L2	n-F	Z	PN
63	50	131680PA2	2"	51	90	172	293	221	112	19-27	38	10
75	65	131681PA2	2½"	69	90	172	310	227	119	19-27	41	10
90	80	131682PA2	3"	78	94	188	346	254	134	19-26	44	10
110	100	131683PA2	4"	101	117	221	390	280	150	21-31	51	10
125	110	131684PA2	-	126	124	268	430	305	167	24-29	59	10
140	125	131685PA2	5"	126	124	268	430	305	167	24-29	59	10
160	150	131686PA2	6"	200	131	279	470	335	181	25-31	55	10
200	175	131687PA2	-	200	149	322	580	420	233	22-30	63	10
225	200	131688PA2	8"	250	149	322	580	420	233	22-30	63	10

\*C1, C2, L and L1 values may vary.



**NEW PRODUCT**

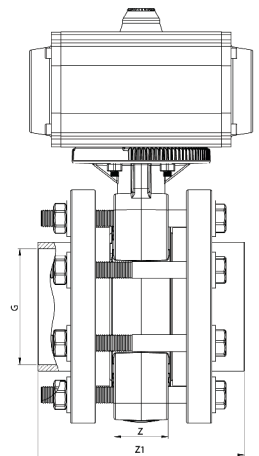
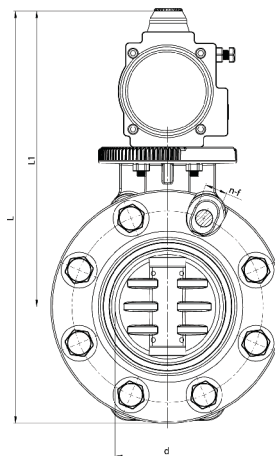
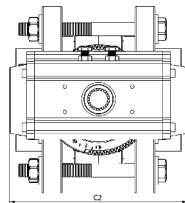

Made from extruded aluminum.  
 Shaft from cadmium plating steel.  
 Pistons from casted aluminum.  
 Quick OPEN/CLOSE compared to electric actuators.  
 Valve fixation according to ISO5211.  
 Complete with flange, flange adaptor and nuts.  
 Shaft made of SS304.  
 Liner from FPM.  
 Screw set from SS316

- SS316 shaft is optional

## Pneumatic Actuated Industrial Butterfly Valve Double Acting - Complete with Flange Set

G	DN	Code	d	C1	C2	L	L1	L2	n-F	Z	Z1	PN
63	50	131700PA2	51	90	172	305	221	112	19-27	38	128	10
75	65	131701PA2	69	90	172	320	227	119	19-27	41	142	10
90	80	131702PA2	78	94	188	355	254	134	19-26	44	167	10
110	100	131703PA2	101	117	221	390	280	150	21-31	51	190	10
125	110	131704PA2	126	124	268	430	305	167	24-29	59	218	10
140	125	131705PA2	126	124	268	430	305	167	24-29	59	230	10
160	150	131706PA2	200	131	279	480	335	181	25-31	55	256	10
200	175	131707PA2	200	149	322	592	420	233	22-30	63	305	10
225	200	131708PA2	250	149	322	592	420	233	22-30	63	330	10

\*C1, C2, L and L1 values may vary.



Wide damper opening distance.  
Damper closure with spring.  
Spring from AISI 316 Stainless Steel  
Oring from FPM.

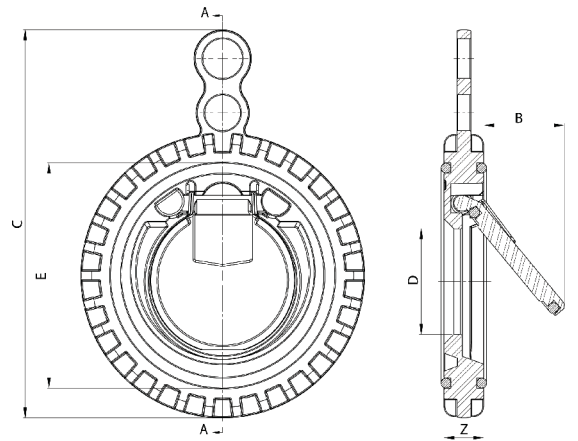

## Industrial Wafer Check Valve

d	DN	inch	Code	D	E	C	Z	B	PN
90	80	3"	131540	53	113	196	20	45	10
110	100	4"	131541	70	140	219	23	62	10
125	110	-	131542	91	161	251	23	90	10
140	125	5"	131543	91	161	251	23	70	10
160	150	6"	131544	100	202	281	25	100	10
200	175	-	131545	125	240	330	33	152	10
225	200	8"	131546	125	240	330	33	160	10
250	250	10"	131547	168	292	394	38	193	10
280	250	-	131548	168	292	394	38	204	10
315	300	12"	131549	220	365	380	43	225	10



Wide damper opening distance.  
Damper closure with spring.  
Spring from AISI 316 Stainless Steel  
Complete with flange adaptors,  
flanges, bolts and nuts from SS316.

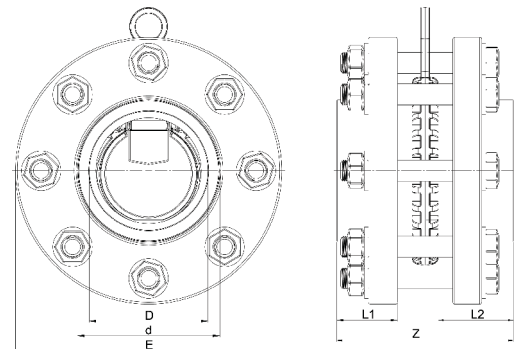

## Industrial Wafer Check Valve Complete with Flange Set

D	DN	Code	d	E	L1	L2	Z	PN	Box
90	80	131550	107	202	46	57	133	10	1
110	100	131551	129,5	222	54,5	65	153	10	1
125	110	131552	147	251	64,5	75	173	10	1
140	125	131553	160,5	251	66,5	81	185	10	1
160	150	131554	189	285	74	90	205	10	1
200	175	131555	225	347	89	113	259	10	1
225	200	131556	250	341	100	125	283	10	1
250	250	131557	276	389	130	147	343	10	1
280	250	131558	305	400	145	165	379	10	1
315	300	131559	343	565	163	185	415	10	1

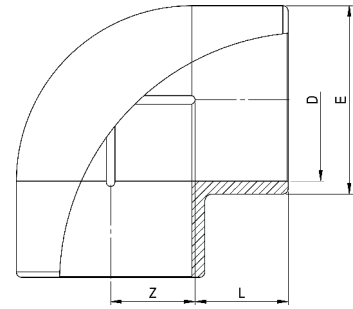

**UPVC SOLVENT  
CEMENT FITTINGS  
EN 1452-3**

**Elbow 90°**

mm	Code	DN	E	D	L	Z	PN	Box
20	133101	16	25	20	16	11	16	250
25	133102	20	31	25	19	13	16	500
32	133103	25	39	32	22	17	16	250
40	133104	32	48	49	26	23	16	150
50	133105	40	58	50	31	20	16	180
63	133106	50	74	63	38	30	16	100
75	133107	65	87	75	44	38	16	70
90	133108	80	104	90	50	44	16	40
110	133109	100	124	110	60	57	16	20
125	133110	110	139	125	69	67	16	16
140	133111	125	155	140	76	71	16	12
160	133112	150	180	160	75	86	16	8
200	133113	175	222	200	106	106.5	10	4
225	133114	200	246	225	119	115.5	10	3
250	133115	250	279	250	131	128	10	2
280	133116	250	317	280	150	140	10	1
315	133117	300	352	315	164	161.5	10	1
355	133118	350	385	355	184	267	10	1
400	133119	400	431	400	203	367	10	1

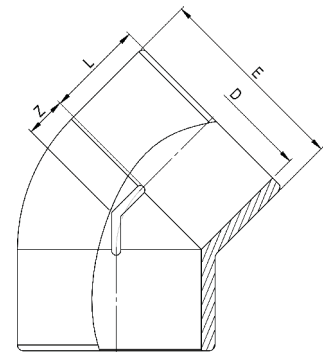

**Elbow 45°**

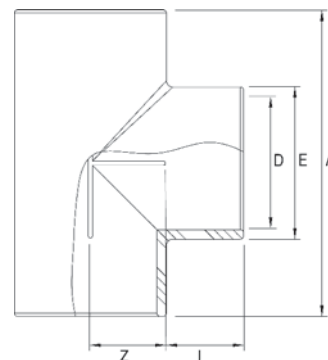
mm	Code	DN	E	D	L	Z	PN	Box
20	133201	16	25	20	16	11	16	600
25	133202	20	31	25	19	13	16	500
32	133203	25	39	32	22	17	16	300
40	133204	32	48	49	26	23	16	150
50	133205	40	58	50	31	20	16	225
63	133206	50	74	63	38	30	16	120
75	133207	65	87	75	44	38	16	100
90	133208	80	104	90	50	44	16	50
110	133209	100	124	110	60	57	16	30
125	133210	110	139	125	69	67	16	18
140	133211	125	155	140	76	71	16	15
160	133212	150	180	160	75	86	16	9
200	133213	175	222	200	106	106.5	10	4
225	133214	200	246	225	119	115.5	10	4
250	133215	250	279	250	131	128	10	1
280	133216	250	317	280	150	140	10	1
315	133217	300	352	315	164	161.5	10	1
355	133218	350	385	355	193	190	10	1
400	133219	400	431	400	206	201	10	1

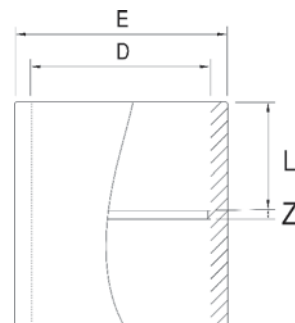

 Tee

mm	Code	DN	A	E	D	L	Z	PN	Box
20	133301	16	58	25	20	16	11	16	150
25	133302	20	66	31	25	19	13	16	300
32	133303	25	78	39	32	22	17	16	200
40	133304	32	98	48	49	26	23	16	100
50	133305	40	120	58	50	30	20	16	115
63	133306	50	145	74	63	38	30	16	75
75	133307	65	166	87	75	44	38	16	50
90	133308	80	200	104	90	50	44	16	30
110	133309	100	238	124	110	60	57	16	20
125	133310	110	268	139	125	69	67	16	11
140	133311	125	294	155	140	76	71	16	8
160	133312	150	332	180	160	75	86	16	5
200	133313	175	415	222	200	106	106.5	10	3
225	133314	200	468	246	225	119	115.5	10	2
250	133315	250	518	279	250	131	128	10	1
280	133316	250	617	317	280	150	140	10	1
315	133317	300	651	352	315	164	161.5	10	1
355	133318	350	739	385	355	184	196	10	1
400	133319	400	792	431	400	186	216	10	1



 Socket

mm	Code	DN	E	D	L	Z	PN	Box
20	133821	16	25	20	16	3	16	500
25	133822	20	31	25	19	2,5	16	500
32	133823	25	39	32	22	2	16	300
40	133824	32	48	49	26	2,5	16	250
50	133805	40	58	50	30	2,5	16	150
63	133806	50	74	63	38	2	16	90
75	133807	65	87	75	44	4	16	96
90	133808	80	104	90	50	4	16	60
110	133809	100	124	110	60	7	16	36
125	133804	110	139	125	69	8,5	16	24
140	133803	125	155	140	76	10	16	15
160	133802	150	180	160	75	11	16	12
200	133810	175	222	200	106	12,5	10	5
225	133811	200	246	225	119	11	10	3
250	133812	250	279	250	131	8	10	2
280	133813	250	317	280	150	10	10	1
315	133814	300	352	315	164	16	10	1
355	133815	350	385	355	184	10	10	1
400	133828	400	400	400	206	7	10	1

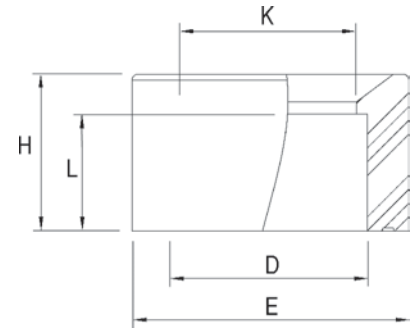

## Reducing Socket

mm	Code	K	H	L	D	E	PN	Box
25-20	133602	16	16	16	20	25	16	250
32-20	133619	22	22	16	20	32	16	1000
32-25	133604	22	22	21	25	32	16	1000
40-20	133577	26	26	16	20	40	16	600
40-32	133603	28	28	28	32	40	16	600
50-32	133601	28	28	28	50	50	16	250
50-40	1336095	38	38	38	50	50	16	250
63-32	1336053	30	30	30	63	63	16	200
63-40	1336052	38	38	38	40	63	16	200
63-50	133605	43	43	43	50	63	16	252
75-40	1336062	38	38	38	40	75	16	150
75-50	1336061	40	40	40	50	75	16	150
75-63	133606	57	57	57	63	75	16	150
90-63	1336071	56	56	56	63	90	16	88
90-75	133607	67	67	67	75	90	16	88
110-63	1336082	56	56	56	63	110	16	48
110-75	1336081	68	68	68	75	110	16	48
110-90	133608	81	81	81	90	110	16	48
125-90	1336091	82	82	82	90	125	16	36
125-110	133609	102	102	102	110	125	16	36
140-90	133612	80	80	80	90	140	16	23
140-110	1336121	100	100	100	110	140	16	23
140-125	1336122	117	117	117	125	140	16	23
160-90	133610	81	81	81	90	160	10	15
160-110	133611	100	100	100	110	160	10	15
160-140	13366111	132	132	132	140	160	10	15
200-140	133671	130	130	130	140	200	10	14
200-160	133672	152	152	152	160	200	10	14
225-160	133682	154	154	154	160	225	10	12
225-200	133681	191	191	191	202	225	10	12
250-225	133683	215	215	215	225	250	10	8
280-250	133686	249	249	249	250	280	10	1
315-250	133693	245	245	245	250	315	10	1
315-280	1336086	273	273	273	280	315	10	1



Flange connection according to:  
 S107005 PN10, EN1092 PN10, BS  
 4504, DIN 2501 PN10, TS EN 1452-3

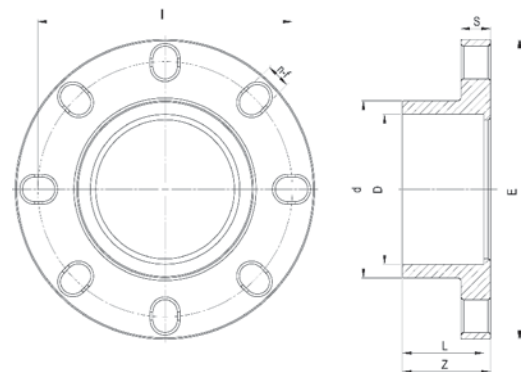

## Fixed Flange

mm	inch	Code	D	I	d	Z	L	E	S	n-f	PN	Box
90	3"	1381008	90	158	108	57	50	201	22	18-24	16	17
110	4"	1381009	110	185	130	65	60	220	22	18-24	16	10



## Reducing Tee

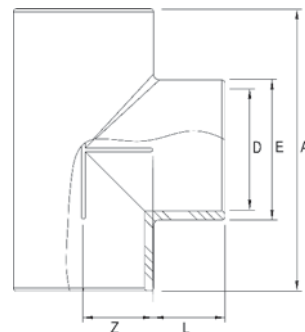

mm	Code	A	E	D	L	Z	PN	Box
50-40	13330051	120	60	40	26	35	16	75
63-50*	13330061	145	72	50	34	38	16	75
75-50	13330071	166	85	50	40	44	16	50
75-63	13330072	166	85	63	40	44	16	50
90-63*	13330081	200	101	63	49	51	16	30
90-75*	13330082	200	101	75	49	51	16	30
110-63*	13330091	238	122	63	57	60	16	20
110-75	13330092	238	122	75	57	60	16	20
110-90*	13330093	238	122	90	57	60	16	20
125-75	13330101	268	139	75	64	76	16	11
125-90	13330102	268	139	90	64	76	16	11
125-110	13330103	268	139	110	64	76	16	11
140-90	13330111	294	156	90	68	76	16	8
140-110	13330112	294	156	110	68	76	16	8
140-125	13330113	294	156	125	68	76	16	8
160-63	13330121	332	180	63	75	85	16	5
160-75	13330122	332	180	75	75	85	16	5
160-90*	13330123	332	180	90	75	85	16	5
160-110*	13330124	332	180	110	75	85	16	5
160-125	13330125	332	180	125	75	85	16	5
160-140*	13330126	332	180	140	75	85	16	5
200-75*	13330131	415	220	75	106	101.5	10	1
200-90*	13330132	415	220	90	106	101.5	10	1
200-110*	13330133	415	220	110	106	101.5	10	1
200-125*	13330134	415	220	125	106	101.5	10	1
200-140*	13330135	415	220	140	106	101.5	10	1
200-160*	13330136	415	220	160	106	101.5	10	1
225-110*	13330141	468	246	110	119	115	10	1
225-125*	13330142	468	246	125	119	115	10	1
225-140*	13330143	468	246	140	119	115	10	1
225-160*	13330144	468	246	160	119	115	10	1
225-200*	13330145	468	246	200	119	115	10	1

\*Marked items are produced by combination of equal tee and reducer.

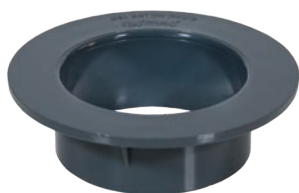

## Wall Conduit Flange

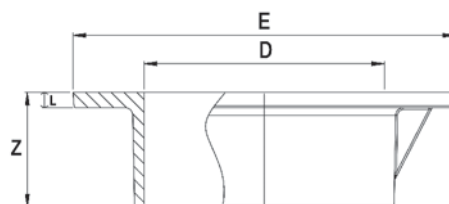

D	Code	E	L	Z
50	041601	80	4	26
63	041602	100	4	30
75	041603	111	4	30
90	041604	129	5	30
110	041605	149	5	30
125	041606	164	5	31
140	041607	180	5	31
160	041608	199	5	31

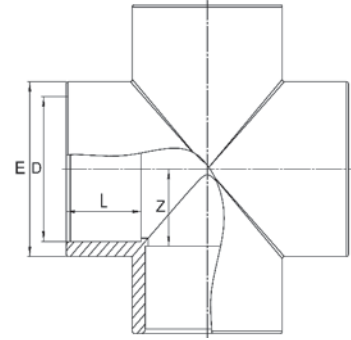

**Cross**

mm	Code	E	D	L	Z	PN	BOX
32	133321	38.5	32	23	17	16	100
40	133322	48	40	29	23	16	50
50	133323	59	50	33	28	16	42
63	133324	72	63	38	34	16	20
75	133325	85	75	44	41	16	30
90	133326	101	90	51	46	16	20
110	133327	122	110	61	55	16	14
125*	133328	139	125	69	67	16	8
140*	133329	156	140	76	71	10	6
160*	133330	180	160	86	86	10	3
200*	133331	220	200	106	101	10	1
225*	133332	246	225	118	114	10	1
250*	133333	276	250	131	132	10	1
280*	133334	317	280	146	152	10	1
315*	133335	352	315	163	168	10	1

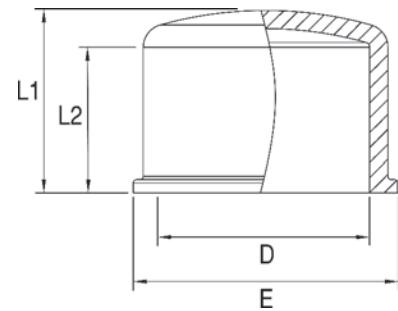
\*Marked items are produced by PVC welding method.

**Cap**

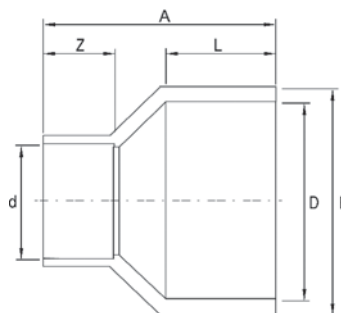
mm	Code	D	E	L1	L2	PN	Box
20	133701	20	25	20	16	16	200
25	133702	25	31	26	19	16	1000
32	133703	32	39	32	22	16	600
40	133704	49	48	37	27	16	360
50	133705	50	58	45	30	16	262
63	133706	63	74	55	43	16	130
75	133707	75	87	60	48	16	80
90	133708	90	104	67	57	16	46
110	133709	110	124	82	66	16	33
125	133711	125	139	118	69	16	20
140	133712	140	155	129	79	16	11
160	133713	160	180	141	89	10	8
200	133714	200	222	147	106	10	6
225	133715	225	246	162.5	119	10	5
250	133716	250	279	183	131	10	4
280	133717	280	317	200	140	10	4
315	133718	315	352	228	164	10	1



## Conical Reduction

mm	Code	D	d	E	A	L	Z	PN
50-32	1339061	50	32	58	66	31	23	16
50-40	1339062	50	40	58	66	31	23	16
63-32	1339063	63	32	74	85	38	30	16
63-40	133906	63	40	74	85	38	30	16
63-50	133905	63	50	74	85	38	30	16
75-50	1339071	75	50	84	91	44	32,7	16
75-63	1339072	79	63	84	94	56	39	16
90-63	1339082	90	63	100,2	109,2	53	39	16
110-63	1339091	110	63	126,5	129,7	61,7	39	16
110-90	1339092	110	90	126,5	129,7	61,7	40,2	10
160-110	13390121	161	110	174,6	186,6	86,6	61,2	10
200-110	13390131	200	110	219	221	108,5	62,5	10



Flange connection according to:  
SIO7005 PN10, EN1092 PN10, BS 4504,  
DIN 2501 PN10, TS EN 1452-3

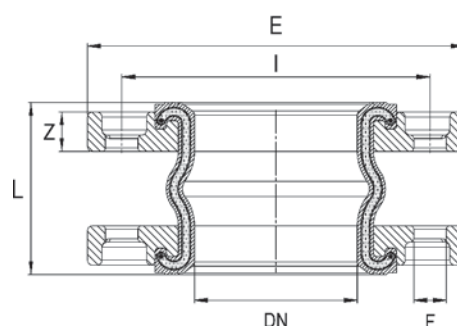

## Vibration Flange

Code	D	mm	E	L1	L2	PN	Box
0141110	25	20	25	20	16	16	200
0141111	32	25	31	26	19	16	1000
0141112	40	32	39	32	22	16	600
0141113	50	40	48	37	27	16	360
0141114	65	50	58	45	30	16	262
0141115	80	63	74	55	43	16	130
0141116	100	75	87	60	48	16	80
0141117	125	90	104	67	57	16	46
0141118	150	110	124	82	66	16	33
0141119	200	125	139	118	69	16	20
0141120	250	140	155	129	79	16	11
0141121	300	160	180	141	89	10	8
0141122	350	200	222	147	106	10	6
0141123	400	225	246	162,5	119	10	5
0141124	450	250	279	183	131	10	4
0141125	500	280	317	200	140	10	4
0141126	600	315	352	228	164	10	-

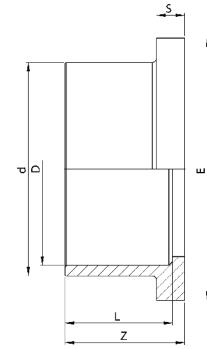

## UPVC Flange Adaptor

D	Code	DN	d	E	L	Z	S	PN	Box
50	133927	40	60	73	35	38	8	16	200
63	133928	50	77	91	38	41	9	16	100
75	133929	65	90	106	43	46	10	16	70
90	133908	80	107	122	52	57	11	16	42
110	133909	100	129,5	147	60,5	65	10,5	16	25
125	133910	110	147	171	68,5	75	13,5	16	15
140	133911	125	160,5	189	75	81	14,5	16	14
160	133912	150	189	215	84	90	16	16	16
200	133913	175	225	252,5	107,5	113	24	10	8
225	133914	200	250	270	118,5	125	25	10	8
250	133915	250	276	305	134	147	27	10	5
280	133916	250	305	325	147	165	20	10	3
315	133917	300	343	371	163,5	185	22	10	3
355	133918	350	384	430	184	194	28	10	3
400	133919	400	450	482	206	216	25	10	1



Flange connection according to:  
 SIO7005 PN10, EN1092 PN10, BS 4504,  
 DIN 2501 PN10, TS EN 1452-3

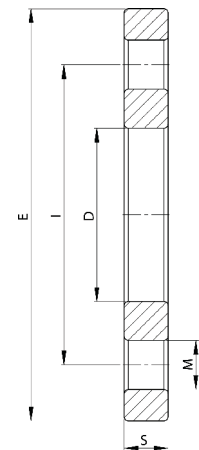

## UPVC Flange

mm	Inch	Code	E	I	D	M (metric)	S	Box
50	1½"	1331005	150	110	63,5	M16	16	70
63	2"	1331006	167	127	78,5	M16	18	60
75	2½"	1331007	186	145	92	M16	19	50
90	3"	1331008	202	163	110	M18	22	40
110	4"	1331009	222	182	131,5	M16	22	34
125	-	1331010	251	211,5	149	M16	22	23
140	5"	1331011	251	211,5	167	M16	25	23
160	6"	1331012	285	241	191	M18	28	25
200	-	1331013	347	296	227	M18	36	16
225	8"	1331014	341	296	251	M22	36	16
250	10"	1331015	389	350	277	M20	37	14
280	-	1331016	400	350	310	M20	37	2
315	12"	1331017	455	400	348	M20	42	2
355	14"	1331018	505	460	388	M20	42	1
400	16"	1331019	565	515	442	M24	42	1



Flange connection according to:  
 SIO7005 PN10, EN1092 PN10, BS 4504,  
 DIN 2501 PN10, TS EN 1452-3

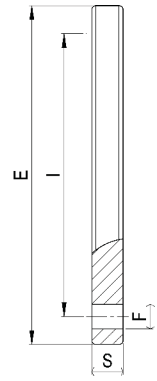

 **UPVC Blind Flange**

mm	Code	inch	E	I	F	S	Box
50	1331105	1½"	150	110	18	17	60
63	1331106	2"	165	125	18	20	50
75	1331107	2½"	185	145	18	21	40
90	1331108	3"	201	144	19	22	34
110	1331109	4"	219	175	17	22	34
125	1331110	-	249	193	18	24	23
140	1331111	5"	249	208	18	24	23
160	1331112	6"	283	218	22	28	20
200	1331113	-	340	295	22	32	10
225	1331114	8"	340	295	22	32	8
250	1331115	10"	394	350	22	36	3
280	1331116	-	400	355	25	36	2
315	1331117	12"	445	400	22	36	1
355	1331118	14"	565	460	22	38	1
400	1331119	16"	565	515	26	40	1



# **UPVC UNIONS & THREADED PARTS**

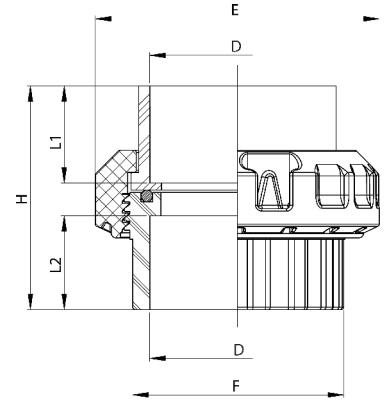

**UPVC Union**  
Solvent Cement

D	DN	Code	E	F	H	L1	L2	PN	Box
20	16	132111	56	29	46	20	16	16	250
25	20	132112	56	34	50	20	18,5	16	200
32	25	132113	64,5	42	55	23,5	22	16	100
40	32	132114	75	52	61	26	26	16	80
50	40	132115	88	61	75	32	32	16	50
63	50	132116	100	88	85	37	39	16	40
75	65	132117	122	91	98	42	40	16	40
90	80	132118	143	109	108,5	42	48	16	30
110	100	132119	160	129	137	56	62	16	15

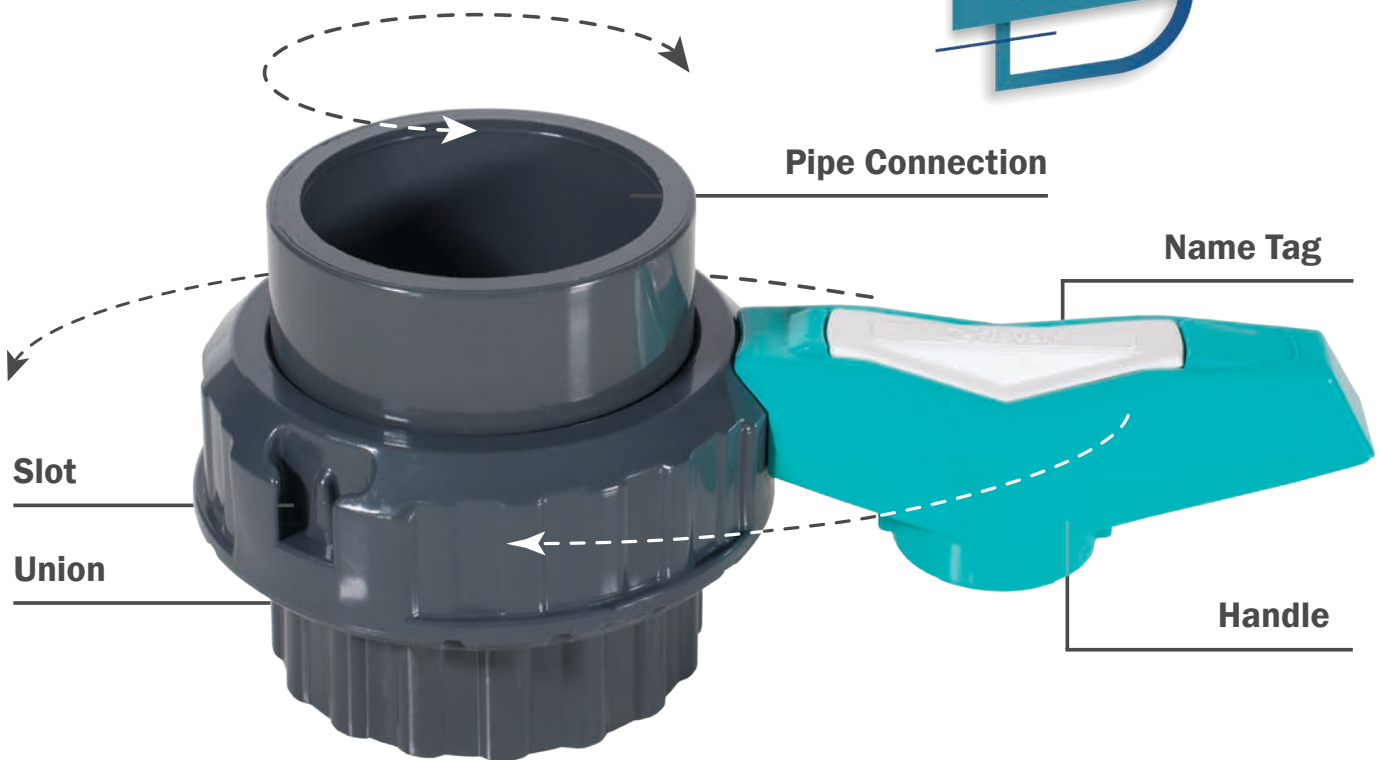

Place the handle to slot and turn the union by handle.  
You can use the union without the handle.



One side BSP Standard female threaded.

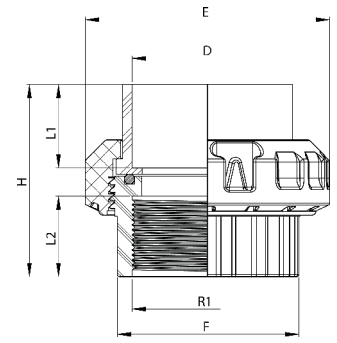

**UPVC Union**  
Solvent Cement x Female Threaded

D	DN	Code	E	F	R1	H	L1	L2	PN	Box
20	16	132111T1	56	29	1/2"	46	20	16	16	250
25	20	132112T1	56	34	3/4"	50	20	18,5	16	200
32	25	132113T1	64,5	42	1"	55	23,5	22	16	100
40	32	132114T1	75	52	1 1/4"	61	26	26	16	80
50	40	132115T1	88	61	1 1/2"	75	32	32	16	50
63	50	132116T1	100	88	2"	85	37	39	16	40
75	65	132117T1	122	91	2 1/2"	98	42	40	16	60
90	80	132118T1	143	109	3"	108,5	42	48	16	30
110	100	132119T1	160	129	4"	137	56	62	16	20



Two sides BSP Standard female threaded.

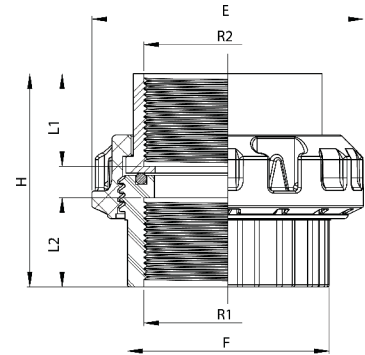

**UPVC Union**  
Female Threaded x Female Threaded

R1	DN	Code	E	F	R2	H	L1	L2	PN	Box
1/2"	16	132111T	56	29	1/2"	46	20	16	16	250
3/4"	20	132112T	56	34	3/4"	50	20	18,5	16	200
1"	25	132113T	64,5	42	1"	55	23,5	22	16	100
1 1/4"	32	132114T	75	52	1 1/4"	61	26	26	16	80
1 1/2"	40	132115T	88	61	1 1/2"	75	32	32	16	50
2"	50	132116T	100	88	2"	85	37	39	16	40
2 1/2"	65	132117T	122	91	2 1/2"	98	42	40	16	60
3"	80	132118T	143	109	3"	108,5	42	48	16	30
4"	100	132119T	160	129	4"	137	56	62	16	20



One side BSP Standard male threaded.  
- O-ring is optional.

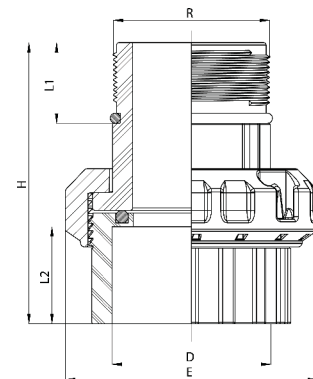

**UPVC Male Union**  
Female Socket x Male Threaded

D	DN	Code	E	H	R	L1	L2	PN	Box
50	40	132121	88	95	1 1/2"	32	32	16	100
63	50	132122	100	112	2"	32	38,5	16	50
63-R	50	132123	100	112	1 1/2"	32	38,5	16	50



One side is high grade brass BSP female threaded.  
Suitable for transition from UPVC to metallic lines.

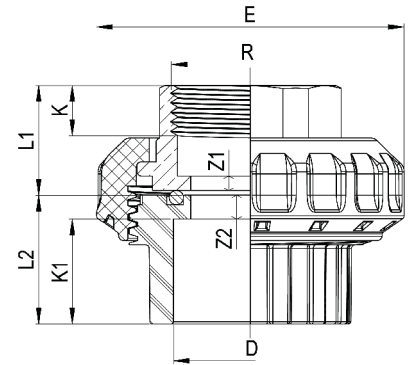

**UPVC Female Union**  
Solvent Cement x Female Brass Threaded

D	Code	E	R	L1	L2	Z1	Z2	K	K1	PN
20	133460	56	1/2"	19	25	3	9	16	16	16
25	133461	56	3/4"	21	29	3	11	18	18,5	16
32	133462	64,5	1"	25	32	3	11	21	22	16
40	133463	75	1 1/4"	29	39	3	16	23	26	16
50	133464	88	1 1/2"	34	45	3	14	31	32	16
63	133465	100	2"	41	55	3	24	31	39	16



Male threaded side and locking ring are made of high grade brass.  
Suitable for transition from UPVC to metallic lines.

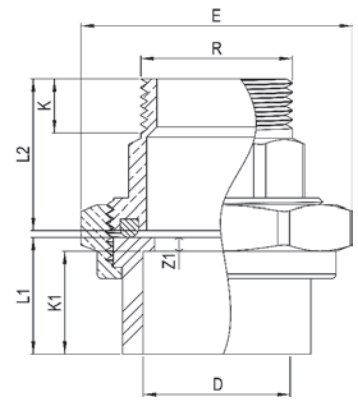

**UPVC Brass Male Union**  
Male Brass Threaded x Solvent Cement

D	Code	E	R	L1	L2	Z1	K	K1	PN
20	133470	36	1/2"	19	22	3	16	16	16
25	133471	45	3/4"	21	24	3	18	18	16
32	133472	51	1"	25	33	3	21	22	16
40	133473	64	1 1/4"	29	39	3	23	26	16
50	133474	80	1 1/2"	34	39	3	31	31	16
63	133475	98	2"	41	40	3	31	38	16



Female threaded side and locking ring are made of high grade brass.  
Suitable for transition from UPVC to metallic lines.

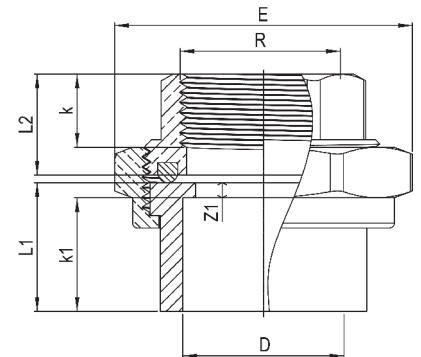

**UPVC Brass Female Union**  
Female Threaded x Solvent Cement

D	Code	E	R	L1	L2	Z1	K	K1	PN
20	133450	36	1/2"	19	25	3	16	16	16
25	133451	45	3/4"	21	29	3	18	18	16
32	133452	51	1"	25	32	3	21	22	16
40	133453	64	1 1/4"	29	39	3	23	26	16
50	133454	80	1 1/2"	34	45	3	31	31	16
63	133455	98	2"	41	55	3	31	38	16



One side is high grade brass BSP male threaded.  
Suitable for transition from UPVC to metallic lines.

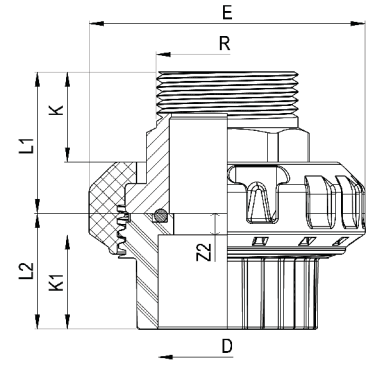

## UPVC Male Union Male Threaded x Solvent Cement

d	Code	D	R	L1	L2	Z2	K	K1	PN
20	133480	36	1/2"	19	25	9	16	16	16
25	133481	45	3/4"	21	29	11	18	18	16
32	133482	51	1"	25	32	11	21	22	16
40	133483	64	1 1/4"	29	39	16	23	26	16
50	133484	80	1 1/2"	34	45	14	31	31	16
63	133485	98	2"	41	55	24	31	38	16



Flange connection according to:  
SI07005 PN10, EN1092 PN10, BS 4504,  
DIN 2501 PN10, TS EN 1452-3

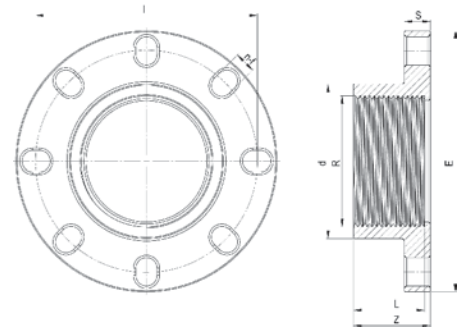

## Threaded Fix Flange

mm/inch	Code	R	l	d	Z	L	E	S	n-f	PN
90/3"	1381008T	3"	158	108	57	50	201	22	18-24	16
110/4"	1381009T	4"	185	130	65	60	220	22	18-24	16

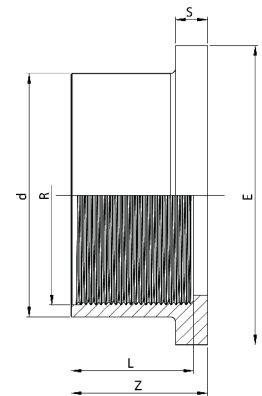

## Female Threaded Flange Adaptor

mm/inch	Code	R	d	E	L	Z	S	PN	BOX
50/1 1/2"	133927T	1 1/2"	60	73	35	38	8	16	200
63/2"	133928T	2"	77	91	38	41	9	16	100
75/2 1/2"	133929T	2 1/2"	90	106	43	46	10	16	70
90/3"	133908T	3"	107	122	52	57	11	16	42
110/4"	133909T	4"	129,5	147	60,5	65	10,5	16	25
125/4 1/2"	133910T	4 1/2"	147	171	68,5	75	13,5	16	15
140/5"	133911T	5"	160,5	189	75	81	14,5	16	14
160/6"	133912T	6"	189	215	84	90	16	16	16
200/7"	133913T	7"	225	252,5	107,5	113	24	10	8
225/8"	133914T	8"	250	270	118,5	125	25	10	8

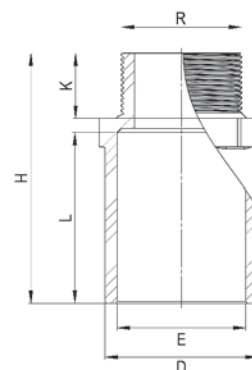

## Male Threaded Adaptor Long Type

mm	Code	D	H	E	L	K	R	PN	Box
50	133505U	50	93	42,5	58,5	20	1½"	16	140
63	133506U	63	110	53,5	66,5	30	2"	16	80
75	133507U	75	132	75	87	30	2½"	16	50
90	133508U	90	149,5	77	101	35	3"	16	30
110	133509U	110	145	97	-	37	4"	16	20

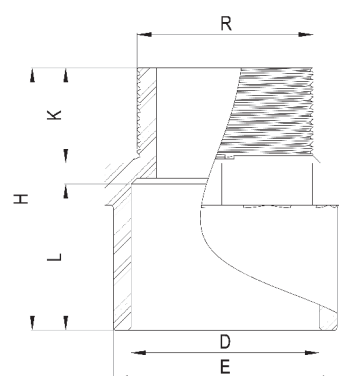

## Reducing Male Threaded Adaptor

mm	Code	E	R	H	D	L	K	PN	Box
20	133501	25	½"	39	20	17	17	16	350
25	133502	32	¾"	43	25	19	20	16	350
32	133503	40	1"	49	32	23	21	16	300
40	133504	50	1¼"	54	40	27	22	16	200
50	133505	63	1½"	77	50	43	30	16	156
63	133506	75	2"	88	63	51	32	16	96
75	133507	90	2½"	98	75	58	31	16	57
90	133508	110	3"	110	90	73	31	16	32
110	133509	125	4"	120	110	70	40	16	18

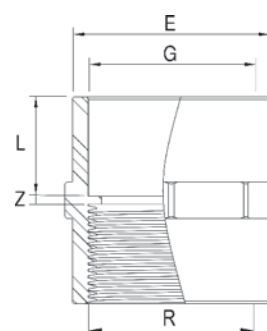

## Reducing Female Threaded Adaptor

G	Code	E	R	Z	L	PN	Box
20	133402	25	½"	3,5	16,5	16	400
25	133403	32	¾"	4	19,5	16	400
32	133404	40	1"	3	22	16	350
40	133401	50	1¼"	3	26,5	16	200
50	133405	63	1½"	3	32	16	120
63	133406	75	2"	3	39	16	75
75	133407	90	2½"	3	44	16	57
90	133408	110	3"	3	51	16	32
110	133409	125	4"	5	60	16	22

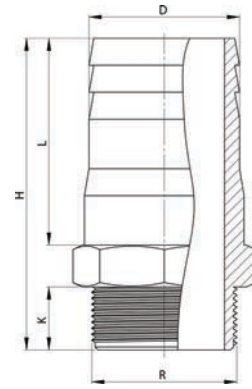

## UPVC Hose Adaptor

inch	Code	D	R	E	H	L	K	PN	Box
1½"	136313	50	1½"	42,5	93	58,5	20	16	140
2"	136316	63	2"	53,5	110	66,5	30	16	80
2½"	136314	75	2½"	75	132	87	30	16	50
3"	136317	90	3"	77	149,5	101	35	16	30
4"	136318	110	4"	97	145	-	37	16	20

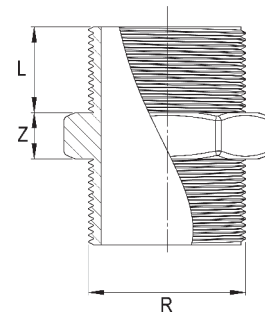

## Nippel

mm/inch	Code	R	L	Z	PN
20/½"	1111080	½"	16	8	16
25/¾"	1111081	¾"	18	10	16
32/1"	1111082	1"	22	12	16
40/1¼"	1111083	1¼"	23	14	16
50/1½"	1111084	1½"	26	14	16
63/2"	1111085	2"	21	12	16
75/2½"	1111086	2½"	24	12	16
90/3"	1111087	3"	26	14	16
110/4"	1111088	4"	32	16	16
125/4½"	1111089	4½"	44	40	16
140/5"	1111090	5"	44	50	16
160/6"	1111091	6"	50	50	10
200/7"	1111092	7"	55	50	10

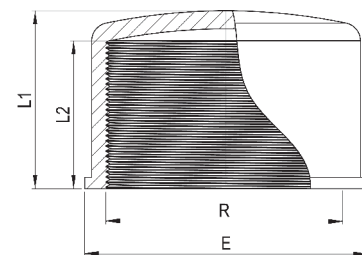

## Female Threaded Cap

mm/inch	Code	R	E	L1	L2	PN
50/1½"	133705T	1½"	64	45	30	16
63/2"	133706T	2"	80	55	43	16
75/2½"	133707T	2½"	86	60	48	16
90/3"	133708T	3"	103	67	57	16
110/4"	133709T	4"	126	82	66	16
125/4½"	133711T	4½"	145	118	69	16
140/5"	133712T	5"	163	129	79	16
160/6"	133713T	6"	188	141	89	10
200/7"	133714T	7"	223,5	147	106	10
225/8"	133715T	8"	251	162,5	119	10

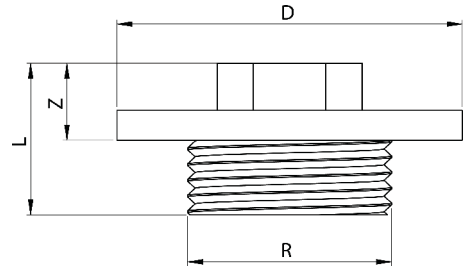

### Male Threaded Cap

mm/inch	Code	R	D	L	Z	PN
50/1½"	133727	1½"	50	15	7	16
63/2"	133726	2"	63	17	10	16
75/2½"	133722	2½"	75	29	12	16
90/3"	133723	3"	90	33	16	16
110/4"	133724	4"	110	43	17	16

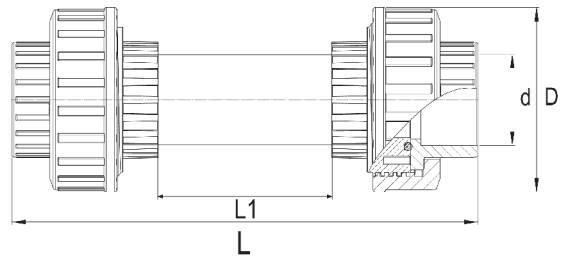

### Union Sight Glass

d	Code	D	L1	L	PN
20	134200	48	100	190	16
25	134201	56	100	205	16
32	134202	67	100	220	16
40	134203	82	100	230	16
50	134204	82	100	255	16
63	134205	106	100	290	16
75	134206	110	100	300	16
90	134207	156	100	340	16
110	134208	179	100	380	16

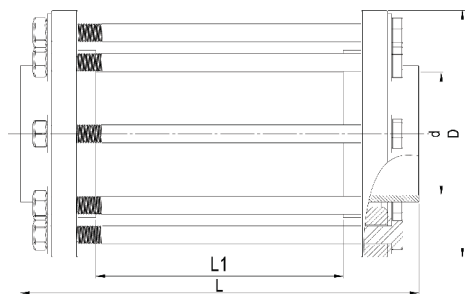

### Flanged Sight Glass

d	Code	D	L1	L	PN
90	134220	200	100	215	16
110	134221	220	100	230	16
125	134222	250	100	250	16
140	134223	250	100	262	16
160	134224	285	100	280	16
200	134225	338	100	326	16
225	134226	341	100	350	16



# **UPVC PIPES & CLAMPS**



## UPVC Pipes Solvent Socket - PN 6

mm	Code - 6 m	PN	S(mm)	kg/m
40	1390600	6	1,5	0,292
50	1390601	6	1,6	0,369
63	1390602	6	2,0	0,574
75	1390603	6	2,3	0,784
90	1390604	6	2,8	1,151
110	1390605	6	2,7	1,427
125	1390606	6	3,1	1,856
140	1390607	6	3,5	2,343
160	1390608	6	4,0	3,055
200	1390609	6	4,9	4,676
225	1390610	6	5,5	5,913
250	1390611	6	6,2	7,414
280	1390612	6	6,9	9,242
315	1390613	6	7,7	11,627
355	1390614	6	8,7	14,831
400	1390615	6	9,8	18,994

\*50 and 63 mm pipes delivered in 3 mt or 6 mt. Please specify.



## UPVC Pipes Solvent Socket - PN 10

mm	Code - 6 m	PN	S(mm)	kg/m
20	1391001	10	1,5	0,174
32	1391002	10	1,6	0,244
40	1391003	10	1,9	0,358
50	1391004	10	2,4	0,552
63	1391005	10	3,0	0,864
75	1391006	10	3,6	1,126
90	1391007	10	4,3	1,766
110	1391008	10	4,2	2,175
125	1391009	10	4,8	2,808
140	1391010	10	5,4	3,546
160	1391011	10	6,2	4,653
200	1391012	10	7,7	7,200
225	1391013	10	8,6	9,070
250	1391014	10	9,6	11,270
280	1391015	10	10,7	14,190
315	1391016	10	12,1	17,641
355	1391017	10	13,6	22,477
400	1391018	10	15,3	28,500



## UPVC Pipes Solvent Socket - PN 16

mm	Code - 6 m	PN	S(mm)	kg/m
20	1391601	16	1,5	0,137
25	1391602	16	1,9	0,215
32	1391603	16	2,4	0,345
40	1391604	16	3,0	0,535
50	1391605	16	3,7	0,821
63	1391606	16	4,7	1,303
75	1391607	16	5,6	1,834
90	1391608	16	6,7	2,639
110	1391609	16	6,6	3,291
125	1391610	16	7,4	4,208
140	1391611	16	8,3	5,287
160	1391612	16	9,5	6,909
200	1391613	16	11,9	10,809
225	1391614	16	13,4	13,747
250	1391615	16	14,8	16,899
280	1391616	16	16,6	21,256
315	1391617	16	18,7	26,997
355	1391618	16	21,1	34,456
400	1391619	16	23,7	43,867

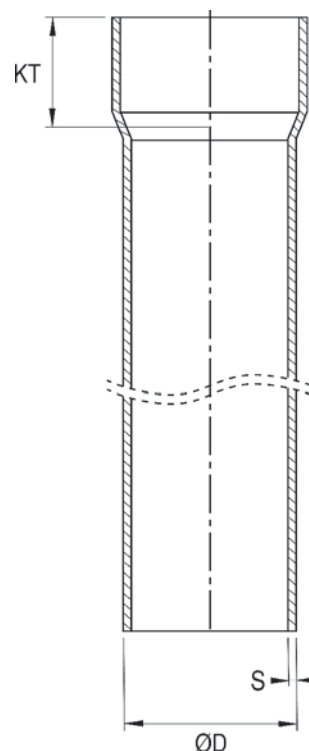



## UPVC Pipes Gasket Socket - PN 6

mm	Code - 6 m	PN	S(mm)	kg/m
50	1390701	6	1,6	0,369
63	1390702	6	2	0,574
75	1390703	6	2,3	0,784
90	1390704	6	2,8	1,151
110	1390705	6	2,7	1,427
125	1390706	6	3,1	1,856
140	1390707	6	3,5	2,343
160	1390708	6	4,0	3,055
200	1390709	6	4,9	4,676
225	1390710	6	5,5	5,913
250	1390711	6	6,2	7,414
280	1390712	6	6,9	9,242
315	1390713	6	7,7	11,627
355	1390714	6	8,7	14,831
400	1390715	6	9,8	18,994



## UPVC Pipes Gasket Socket - PN 10

mm	Code - 6 m	PN	S(mm)	kg/m
50	1391704	10	2,4	0,552
63	1391705	10	3,0	0,864
75	1391706	10	3,6	1,226
90	1391707	10	4,3	1,766
110	1391708	10	4,2	2,175
125	1391709	10	4,8	2,808
140	1391710	10	5,4	3,546
160	1391711	10	6,2	4,653
200	1391712	10	7,7	7,200
225	1391713	10	8,6	9,070
250	1391714	10	9,6	11,270
280	1391715	10	10,7	14,190
315	1391716	10	12,1	17,641
355	1391717	10	13,6	22,477
400	1391718	10	15,3	28,500

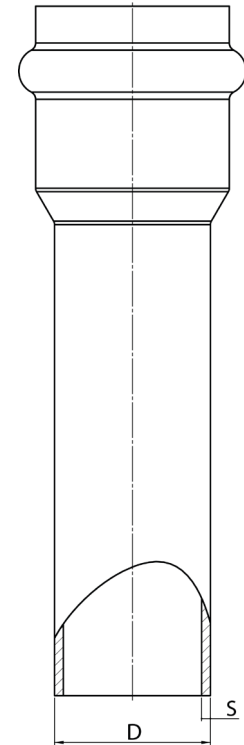

## UPVC Pipes Gasket Socket - PN 16

mm	Code - 6 m	PN	S(mm)	kg/m
50	1391805	16	3,7	0,821
63	1391806	16	4,7	1,303
75	1391807	16	5,6	1,834
90	1391808	16	6,7	2,639
110	1391809	16	6,6	3,291
125	1391810	16	7,4	4,208
140	1391811	16	8,3	5,287
160	1391812	16	9,5	6,909
200	1391813	16	11,9	10,809
225	1391814	16	13,4	13,747
250	1391815	16	14,8	16,899
280	1391816	16	16,6	21,256
315	1391817	16	18,7	26,997
355	1391818	16	21,1	34,459
400	1391819	16	23,7	43,867



## EPDM Flat Gasket

mm	Code	d	E	Z
63	13390799	51	77	3
75	13390800	65	95	3
90	13390801	80	120	3
110	13390802	102	149	5
125	13390803	112	164	4
140	13390804	130	184	3
160	13390805	150	210	4
200	13390806	190	250	5
225	13390807	200	265	4

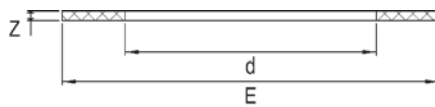

## UPVC Pipe Clamp

mm	Code	D	H	Z
20	133350	31	29	15
25	133351	35	60	16
32	133352	49	40	14
40	133353	54	46	19
50	133354	67	66	18
63	133355	91	101	25
75	133356	93	101	23
90	133357	136	138	25
110	133358	135	126	23
125	133359	159	159	25
140	133360	197	207	30
160	133361	240	235	30

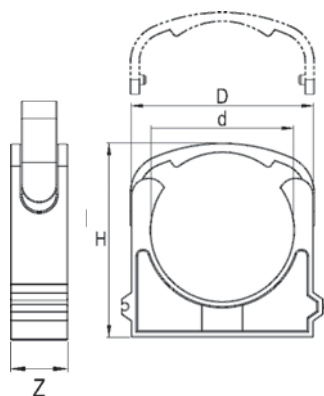

## Repair Socket

mm	Code	Z	PN	Box
50	133850	195±10	10	45
63	133851	200±10	10	28
75	133852	205±10	10	18
90	133853	237±10	10	14
110	133854	290±10	10	9
125	133855	278±10	10	-
140	133856	186±10	10	-
160	133857	308±10	10	-
200	133858	335±10	10	-
225	133859	376±10	10	-
250	133860	405±10	10	-
280	133861	460±10	10	-
315	133862	516±10	10	-
355	133863	562±10	10	-
400	133864	602±10	10	-

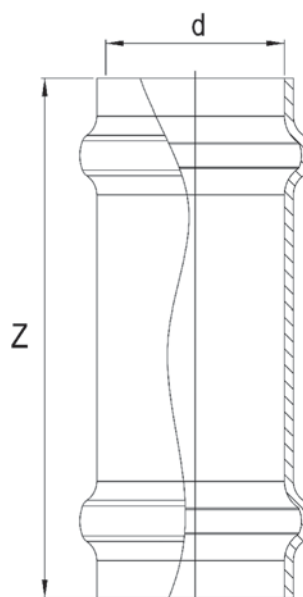



### Metal Pipe Clamp Standard Triphone Clamp

Dim	Code	range	Box
½"	FVTF015	20-25	200
¾"	FVTF020	25-30	150
1"	FVTF025	32-37	150
1 ¼"	FVTF032	40-46	100
1 ½"	FVTF040	48-53	75
53-59	FVTF047	53-59	75
2"	FVTF050	60-66	50
67-77	FVTF060	67-77	40
2½"	FVTF065	75-84	40
83-93	FVTF075	83-93	40
3"	FVTF080	87-96	40
94-1044	FVTF085	94-104	40
102-111	FVTF095	102-111	40
4"	FVTF100	109-119	30
122-135	FVTF110	122-135	30
5"	FVTF125	135-148	25
151-164	FVTF140	151-164	25
6"	FVTF150	158-170	20



### Metal Pipe Clamp Long Triphone Clamp

Dim	Code	range	Box
½"	FVTU015	20-25	200
¾"	FVTU020	25-30	150
1"	FVTU025	32-37	150
1 ¼"	FVTU032	40-46	100
1 ½"	FVTU040	48-53	75
53-59	FVTU047	53-59	75
2"	FVTU050	60-66	50
67-77	FVTU060	67-77	40
2½"	FVTU065	75-84	40
83-93	FVTU075	83-93	40
3"	FVTU080	87-96	40
94-1044	FVTU085	94-104	40
102-111	FVTU095	102-111	40
4"	FVTU100	109-119	30
122-135	FVTU110	122-135	30
5"	FVTU125	135-148	25
151-164	FVTU140	151-164	25
6"	FVTU150	158-170	20



### Metal Pipe Clamp Nut Clamp

Dim	Code	range	Box
½"	FVSK015	20-25	200
¾"	FVSK020	25-30	150
1"	FVSK025	32-37	150
1 ¼"	FVSK032	40-46	100
1 ½"	FVSK040	48-53	75
53-59	FVSK047	53-59	75
2"	FVSK050	60-66	50
67-77	FVSK060	67-77	40
2½"	FVSK065	75-84	40
83-93	FVSK075	83-93	40
3"	FVSK080	87-96	40
94-104	FVSK085	94-104	40
102-111	FVSK095	102-111	40
4"	FVSK100	109-119	30
122-135	FVSK110	122-135	30
128-139	FVSK120	128-139	30
5"	FVSK125	135-148	25
151-164	FVSK140	151-164	25
6"	FVSK150	158-170	20
194-205	FVSK180	194-205	15
8"	FVSK200	214-224	15



### Metal Pipe Clamp Nut Clamp-Heavy Duty

Dim	Code	range	Box
½"	FVAK015	21-28	50
¾"	FVAK020	25-32	50
1"	FVAK025	33-40	50
1 ¼"	FVAK032	41-48	40
1 ½"	FVAK040	48-53	40
53-59	FVAK047	53-59	30
2"	FVAK050	60-69	30
67-77	FVAK060	67-75	252
2½"	FVAK065	75-81	25
83-93	FVAK075	83-91	30
3"	FVAK080	87-95	30
94-104	FVAK085	95-104	25
102-111	FVAK095	102-112	25
4"	FVAK100	109-119	25
122-135	FVAK110	122-138	10
128-139	FVAK120	128-141	10
5"	FVAK125	136-147	10
151-164	FVAK140	153-164	10
6"	FVAK150	164-174	10
194-205	FVAK180	196-209	10
8"	FVAK200	214-226	15



**UPVC SCH80  
VALVES & FITTINGS**



**Ball Valve**  
Solvent Cement - ASTM

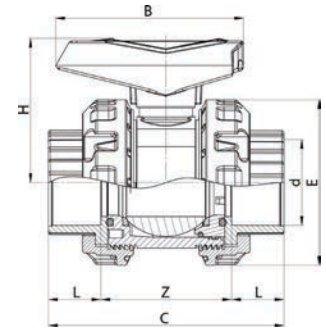

inch	Code	d	B	H	E	L	Z	C	PN	Box
1"	131113LASTM	33,4	92	66	75	23,5	60	107	16	
1½"	131115LASTM	48,3	116	95	100	33	80	146	16	6
2"	131116LASTM	60,3	137	106	122	38	93	169	16	6
3"	131118LASTM	88,9	161	113	143	52	114	221	16	2
4"	131119LASTM	114,3	248	171	226	60	166	286	16	1



**Ball Valve**  
Solvent Cement x Female Threaded - ASTM

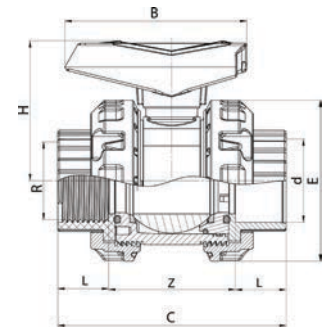

inch	Code	d	R	B	H	E	L	Z	C	PN	Box
1"	131113LT1ASTM	33,4	1"	92	66	75	23,5	60	107	16	20
1½"	131115LT1ASTM	48,3	1½"	116	95	100	33	80	146	16	12
2"	131116LT1ASTM	60,3	2"	137	106	122	38	93	169	16	6
3"	131118LT1ASTM	88,9	3"	161	113	143	52	114	221	16	2
4"	131119LT1ASTM	114,3	4"	248	171	226	60	166	286	16	1



NEW PRODUCT

One side BSP Standard female threaded brass.

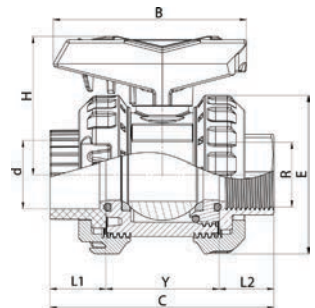

**Ball Valve**  
Female Threaded Brass x Solvent Cement - ASTM

inch	Code	d	R	B	H	E	L1	L2	Y	C	PN	Box
1"	131113LBASTM	33,4	1"	92	66	75	27	28	53	108	16	20
1½"	131115LBASTM	48,3	1½"	116	95	100	38	39	70	147	16	12
2"	131116LBASTM	60,3	2"	137	106	122	42,5	43,5	84	170	16	6
3"	131118LBASTM	88,9	3"	161	113	143	58	59	100	217	16	2
4"	131119LBASTM	114,3	4"	248	171	226	65	66	150	281	16	1



NEW PRODUCT

One side BSP Standard male threaded brass.

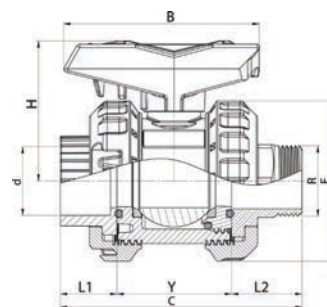

**Ball Valve**  
Male Threaded Brass x Solvent Cement - ASTM

inch	Code	d	R	B	H	E	L1	L2	Y	C	PN	Box
1"	131113LB3ASTM	33,4	1"	92	66	75	27	56	53	136	16	20
1½"	131115LB3ASTM	48,3	1½"	116	95	100	38	57	70	165	16	12
2"	131116LB3ASTM	60,3	2"	137	106	122	42,5	73,5	84	200	16	6
3"	131118LB3ASTM	88,9	3"	161	113	143	58	89	100	247	16	2
4"	131119LB3ASTM	114,3	4"	248	171	226	65	96	150	311	16	1



## Single Union Ball Valve

Solvent Cement - ASTM

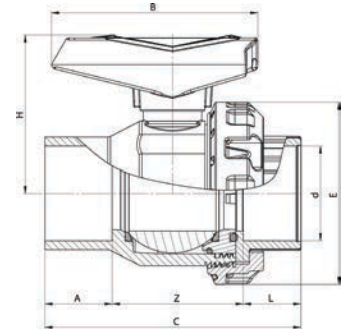

inch	Code	d	B	H	E	L	A	Z	C	PN	Box
1"	131413ASTM	33,4	92	66	75	23,5	22,5	56,5	103	16	20
1½"	131415ASTM	48.3	116	95	100	33	38	72,5	143	16	12
2"	131416ASTM	60.3	137	106	122	38	43	90	172	16	6
3"	131418ASTM	88.9	161	113	143	52	47	101	192	16	2



## Single Union Ball Valve

Solvent Cement x Female Threaded - ASTM

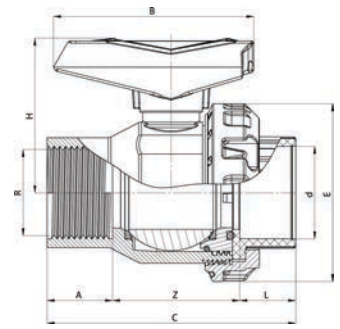

inch	R	Code	d	B	H	E	L	A	Z	C	PN	Box
1"	1"	131413T1ASTM	33,4	92	66	75	23,5	22,5	56,5	103	16	20
1½"	1½"	131415T1ASTM	48.3	116	95	100	33	38	72,5	143	16	12
2"	2"	131416T1ASTM	60.3	137	106	122	38	43	92	172	16	6
3"	3"	131418T1ASTM	88.9	161	113	143	52	47	101	192	16	2



## Single Union Ball Valve

Solvent Cement x Male Threaded - ASTM

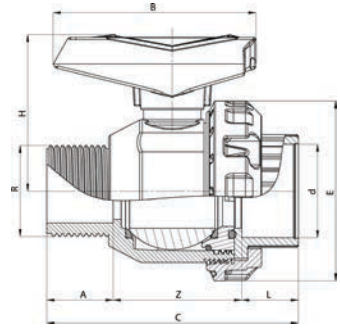

inch	R	Code	d	B	H	E	L	A	Z	C	PN	Box
1"	1"	131413T2ASTM	33,4	92	66	75	23,5	22,5	58,5	103	16	20
1½"	1½"	131415T2ASTM	48.3	116	95	100	33	38	72,5	143	16	12
2"	2"	131416T2ASTM	60.3	137	106	122	38	43	90	172	16	6
3"	3"	131418T2ASTM	88.9	161	113	143	52	47	101	192	16	2



## Actuator Mountable Ball Valve

Solvent Cement - ASTM

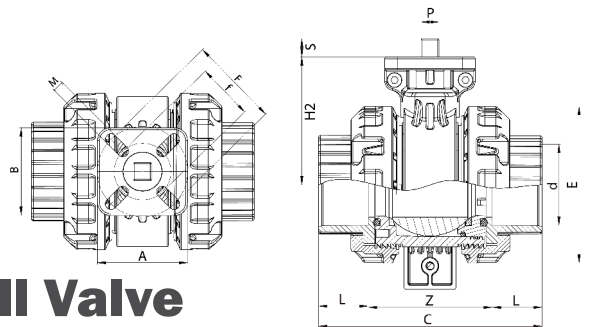

inch	Code	d	A	B	C	E	H2	L	M(metric)	ISO5211	f-F	P	S	Z	PN
1"	131113LAS	33,4	52	52	107	75	61	23,5	6	F03-F05	36-50	11	14	60	16
1½"	131115LAS	48.3	70	68	146	100	92	33	8	F05-F07	50-70	14	17	80	16
2"	131116LAS	60.3	70	68	169	122	100	38	8	F05-F07	50-70	14	17	93	16
3"	131118LAS	88.9	70	68	221	143	107	52	8	F05-F07	50-70	14	17	114	16
4"	131119LAS	114.3	105	105	286	226	154	60	10	F07-F10	70-102	17	19	166	16

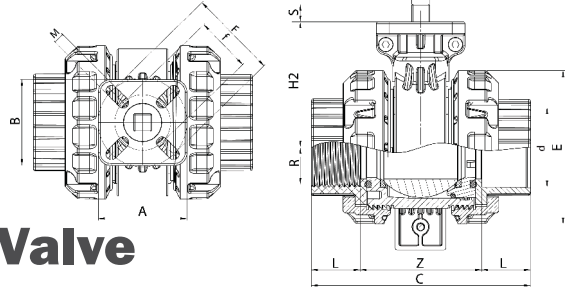

## Actuator Mountable Ball Valve

Solvent Cement x Female Threaded- ASTM

inch	R	Code	d	A	B	C	E	H2	L	M(metric)	ISO5211	f-F	P	S	Z	PN
1"	1"	131113LAT1AS	33,4	52	52	107	75	61	23,5	6	F03-F05	36-50	11	14	60	16
1½"	1½"	131115LAT1AS	48.3	70	68	146	100	92	33	8	F05-F07	50-70	14	17	80	16
2"	2"	131116LAT1AS	60.3	70	68	169	122	100	38	8	F05-F07	50-70	14	17	93	16
3"	3"	131118LAT1AS	88.9	70	68	221	143	107	52	8	F05-F07	50-70	14	17	114	16
4"	4"	131119LAT1AS	114.3	105	105	286	226	154	60	10	F07-F10	70-102	17	19	166	16

\*C1, C2, H and H1 values may vary.

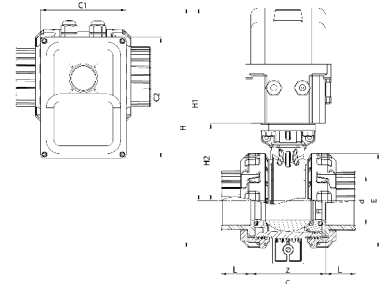

## Electric Actuated Ball Valve

Solvent Cement - 24VDC - ASTM

inch	Code	d	C	C1	C2	E	H	H1	H2	L	Z	PN	Box
1"	131113LEAS	33,4	107	96	137	75	228	190	61	23,5	60	16	1
1½"	131115LEAS	48.3	146	110	155	100	289	239	92	33	80	16	1
2"	131116LEAS	60.3	169	110	155	122	309	248	100	38	93	16	1
3"	131118LEAS	88.9	221	110	155	143	333	262	107	52	114	16	1
4"	131119LEAS	114.3	286			226			154	60	166	16	1

\*C1, C2, H and H1 values may vary.

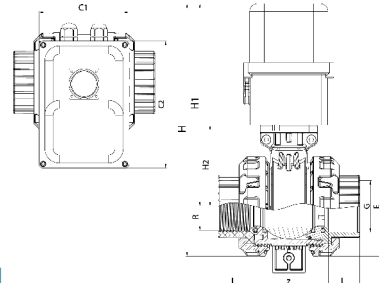

## Electric Actuated Ball Valve

Solvent Cement x Female Threaded - 24VDC - ASTM

inch	R	Code	d	C	C1	C2	E	H	H1	H2	L	Z	PN	Box
1"	1"	131113LEAT1AS	33,4	107	96	137	75	228	190	61	23,5	60	16	1
1½"	1½"	131115LEAT1AS	48.3	146	110	155	100	289	239	92	33	80	16	1
2"	2"	131116LEAT1AS	60.3	169	110	155	122	309	248	100	38	93	16	1
3"	3"	131118LEAT1AS	88.9	221	110	155	143	333	262	107	52	114	16	1
4"	4"	131119LEAT1AS	114.3	286			226			154	60	166	16	1

\*C1, C2, H and H1 values may vary.

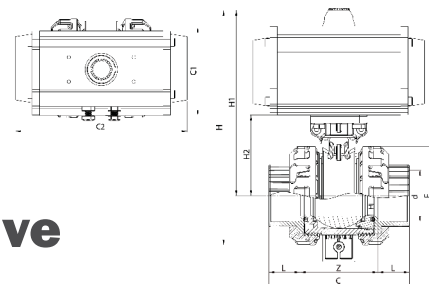

## Pneumatic Actuated Ball Valve

Solvent Cement - Single Acting - ASTM

inch	Code	d	C	C1	C2	E	H	H1	H2	L	Z	PN	Box
1"	131113LPA1AS	33,4	107	80	150	75	197	160	61	23,5	60	16	1
1½"	131115LPA1AS	48.3	146	94	188	100	261	211	92	33	80	16	1
2"	131116LPA1AS	60.3	169	94	188	122	281	220	100	38	93	16	1
3"	131118LPA1AS	88.9	221	124	268	143	315	244	107	52	114	16	1
4"	131119LPA1AS	114.3	286	149	322	226	450	337	154	60	166	16	1

\*C1, C2, H and H1 values may vary.

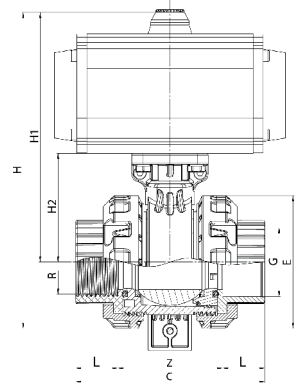
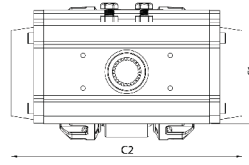

**Pneumatic Actuated Ball Valve**  
Solvent Cement x Female Threaded - ASTM - Single Acting

inch	R	Code	d	C	C1	C2	E	H	H1	H2	L	Z	PN	Box
1"	1"	131113LPA1T1AS	33.4	107	80	150	75	197	160	61	23,5	60	16	1
1½"	1½"	131115LPA1T1AS	48.3	146	94	188	100	261	211	92	33	80	16	1
2"	2"	131116LPA1T1AS	60.3	169	94	188	122	281	220	100	38	93	16	1
3"	3"	131118LPA1T1AS	88.9	221	124	268	143	315	244	107	52	114	16	1
4"	4"	131119LPA1T1AS	114.3	286	149	322	226	450	337	154	60	166	16	1

\*C1, C2, H and H1 values may vary.

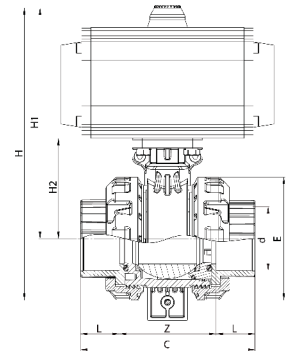
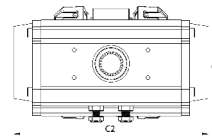

**Pneumatic Actuated Ball Valve**  
Solvent Cement - ASTM - Double Acting

inch	Code	d	C	C1	C2	E	H	H1	H2	L	Z	PN	Box
1"	131113LPA2AS	33.4	107	80	150	75	197	160	61	23,5	60	16	1
1½"	131115LPA2AS	48.3	146	94	188	100	261	211	92	33	80	16	1
2"	131116LPA2AS	60.3	169	94	188	122	281	220	100	38	93	16	1
3"	131118LPA2AS	88.9	221	124	268	143	315	244	107	52	114	16	1
4"	131119LPA2AS	114.3	286	149	322	226	450	337	154	60	166	16	1

\*C1, C2, H and H1 values may vary.

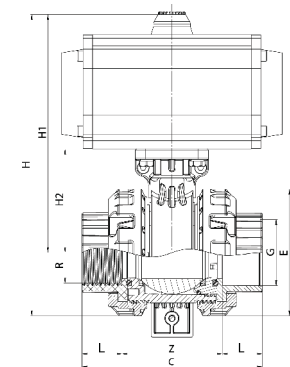
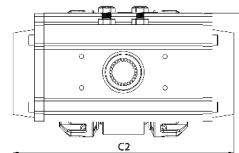

**Pneumatic Actuated Ball Valve**  
Solvent Cement x Female Threaded - ASTM - Double Acting

inch	R	Code	d	C	C1	C2	E	H	H1	H2	L	Z	PN	Box
1"	1"	131113LPA2T1AS	33.4	107	80	150	75	197	160	61	23,5	60	16	1
1½"	1½"	131115LPA2T1AS	48.3	146	94	188	100	261	211	92	33	80	16	1
2"	2"	131116LPA2T1AS	60.3	169	94	188	122	281	220	100	38	93	16	1
3"	3"	131118LPA2T1AS	88.9	221	124	268	143	315	244	107	52	114	16	1
4"	4"	131119LPA2T1AS	114.3	286	149	322	226	450	337	154	60	166	16	1

\*C1, C2, H and H1 values may vary.

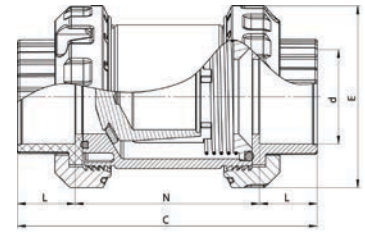

**Spring Check Valve**  
Solvent Cement - ASTM

inch	Code	d	L	N	C	E	PN	Box
1½"	131315ASTM	48.3	33	106	172	100	16	6
2"	131316ASTM	60.3	38	123	199	122	16	6
3"	131318ASTM	88.9	52	149	253	148	16	2

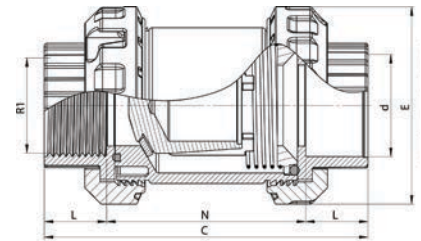

**Spring Check Valve**  
Solvent Cement x Female Threaded - ASTM

inch	R1	Code	d	L	N	C	E	PN	Box
1½"	1½"	131315T1ASTM	48.3	33	106	172	100	16	6
2"	2"	131316T1ASTM	60.3	38	123	199	122	16	6
3"	3"	131318T1ASTM	88.9	52	149	253	148	16	2

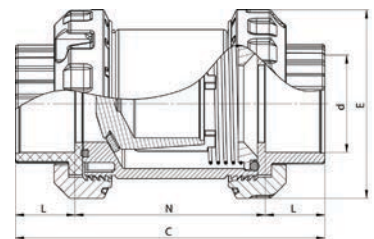

**Spring Transparent Check Valve**  
Solvent Cement - ASTM

inch	Code	d	L	N	C	E	PN	Box
1½"	131315PCASTM	48.3	33	106	172	100	16	6
2"	131316PCASTM	60.3	38	123	199	122	16	6
3"	131318PCASTM	88.9	52	149	253	148	16	2

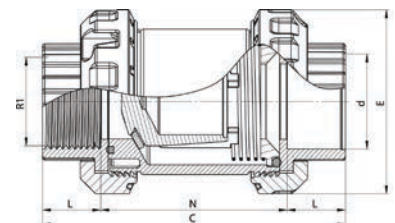

**Spring Transparent Check Valve**  
Solvent Cement x Female Threaded - ASTM

inch	R1	Code	d	L	N	C	E	PN	Box
1½"	1½"	131315PCT1ASTM	48.3	33	106	172	100	16	6
2"	2"	131316PCT1ASTM	60.3	38	123	199	122	16	6
3"	3"	131318PCT1ASTM	88.9	52	149	253	148	16	2



## Wafer Check Valve ASTM

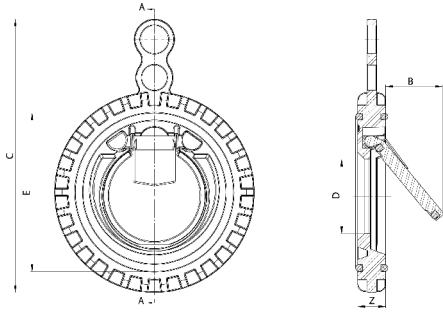

inch	Code	D	E	C	Z	B	PN
3"	131530ASTM	53	113	196	20	45	10
4"	131531ASTM	70	140	219	23	62	10
5"	131533ASTM	91	161	251	23	70	10
6"	131534ASTM	100	202	281	25	100	10
8"	131536ASTM	125	240	330	33	160	10



## Wafer Check Valve Complete with Flange Set -ASTM

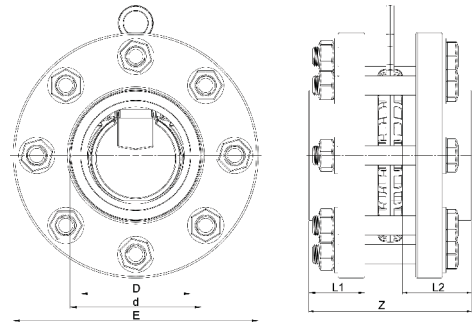

inch	Code	D	d	E	L1	L2	Z	PN	Box
3"	131502ASTM	88,9	107	202	46	57	133	10	1
4"	131503ASTM	114,3	129,5	222	54,5	65	153	10	1
5"	131505ASTM	141,3	160,5	251	66,5	81	185	10	1
6"	131506ASTM	168,3	189	285	74	90	205	10	1



## Butterfly Valve without Flange Set

- SS316 shaft optional

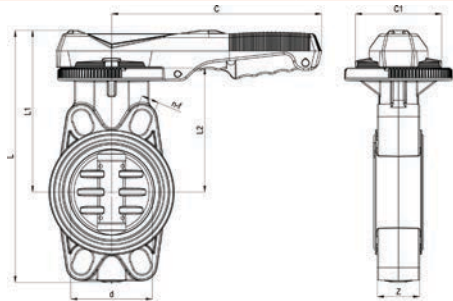

inch	mm	Code	d	C	C1	L	L1	L2	n-F	Z	PN	Box
2"	60,3	131620ASTM	51	185	72	220	147	112	19-27	38	10	10
3"	88,9	131622ASTM	78	209	86	264	172	134	19-26	44	10	8
4"	114,3	131623ASTM	101	255	105	307	195	150	21-31	51	10	5
5"	141,3	131625ASTM	126	255	105	340	215	167	24-29	59	10	4
6"	168,3	131626ASTM	146	310	105	365	228	181	25-31	65	10	3
8"		131628ASTM	200	335	119	452	290	233	22-30	63	10	1



## Butterfly Valve Complete with Flange Set

- SS316 shaft optional.  
- SS316 screw set is optional.

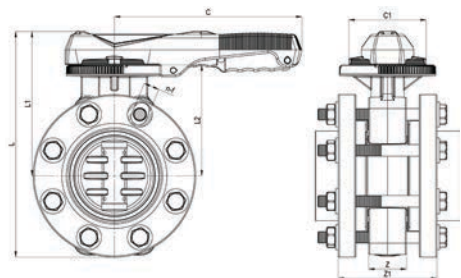

inch	mm	Code	d	C	C1	L	L1	L2	n-F	Z	Z1	PN	Box
2"	60,3	131600ASTM	51	185	72	220	147	112	19-27	38	128	10	1
3"	88,9	131602ASTM	78	209	86	264	172	134	19-26	44	167	10	1
4"	114,3	131603ASTM	101	255	105	307	195	150	21-31	51	190	10	1
5"	141,3	131605ASTM	126	255	105	340	215	167	24-29	59	230	10	1
6"	168,3	131606ASTM	146	225	105	365	228	181	25-31	65	256	10	1



**Elbow 90°**  
ASTM

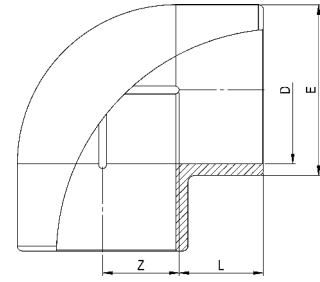

inch	Code	E	D	L	Z	PN	Box
1"	133103ASTM	39	33,4	22	17	16	250
1½"	133105ASTM	58	48,3	30	20	16	180
2"	133106ASTM	74	60,3	38	30	16	100
3"	133108ASTM	104	88,9	50	44	16	50
4"	133109ASTM	124	114,3	60	57	16	27



**Elbow 45°**  
ASTM

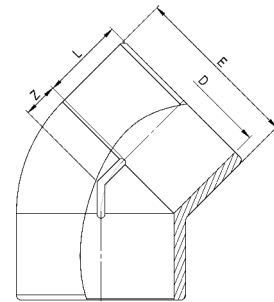

inch	Code	E	D	L	Z	PN	Box
1"	133203ASTM	39	33,4	22	17	16	320
1½"	133205ASTM	58	48,3	30	23	16	225
2"	133206ASTM	74	60,3	38	30	16	150
3"	133208ASTM	104	88,9	50	44	16	50



**Tee**  
ASTM

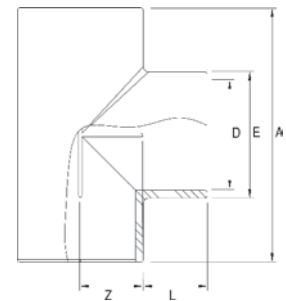

inch	Code	A	E	D	L	Z	PN	Box
1"	133303ASTM	78	39	33,4	22	17	16	200
1½"	133305ASTM	120	58	48,3	30	20	16	115
2"	133306ASTM	145	74	60,3	38	30	16	75
3"	133308ASTM	200	104	88,9	50	44	16	30
4"	133309ASTM	238	124	114,3	60	57	16	20



**Socket**  
ASTM

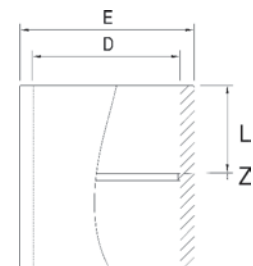

inch	Code	E	D	L	Z	PN	Box
1"	133823ASTM	39	33,4	22	2	16	300
1½"	133805ASTM	58	48,3	30	2,5	16	150
2"	133806ASTM	74	60,3	38	2	16	87
3"	133808ASTM	104	88,9	50	4	16	60
4"	133809ASTM	124	114,3	60	7	16	36



## Conversion Socket

Metric - ASTM

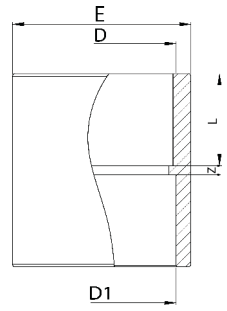

inch	Code	E	D	D1	L	Z	PN	Box
1"	133823ASTM1	39	33.4	32	22	3	16	300
1½"	133805ASTM1	58	48.3	50	30	3	16	150
2"	133806ASTM1	74	60,3	63	38	3	16	87
3"	133808ASTM1	104	88,9	90	50	2	16	60



## Reducing Socket

ASTM

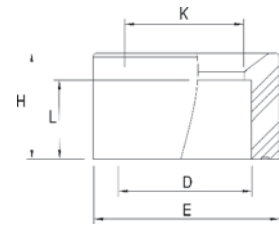

inch	Code	K	H	L	D	PN	Box
1½"-1"	133601ASTM	28	28	28	50	16	200
2"-1"	1336053ASTM	30	30	30	63	16	200
2"-1½"	133605ASTM	43	43	43	50	16	252
3"-2"	1336071ASTM	56	56	56	63	16	88
3"-2½"	133607ASTM	67	67	67	75	16	88



## Cap

ASTM

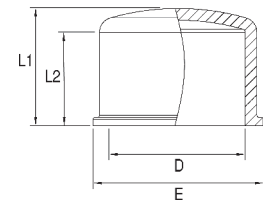

inch	Code	D	E	L1	L2	PN	Box
1"	133703ASTM	33.4	39	32	22	16	600
1½"	133705ASTM	48.3	58	45	30	16	262
2"	133706ASTM	60,3	74	55	43	16	130
3"	133708ASTM	88,9	104	67	57	16	46



## UPVC Flange Adaptor

ASTM

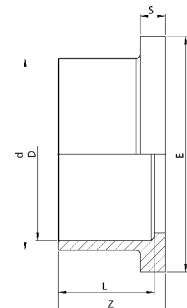

inch	Code	D	d	E	L	Z	S	PN	Box
1"	133903ASTM	33.4	41	50	22	25	7	16	200
1½"	133927ASTM	48.3	60	73	35	38	8	16	200
2"	133928ASTM	60,3	77	91	38	41	9	16	100
3"	133908ASTM	88,9	107	122	52	57	11	16	42
4"	133909ASTM	114,3	129,5	147	60,5	65	10,5	16	25
5"	133911ASTM	141,3	160,5	189	75	81	14,5	16	14
6"	133912ASTM	168,3	189	215	84	90	16	16	16
7"	133913ASTM	-	225	252,5	107,5	113	24	10	8
8"	133914ASTM	219,1	250	270	118,5	125	25	10	8



Flange connection according to:  
 SIO7005 PN10, EN1092 PN10, BS 4504,  
 DIN 2501 PN10, TS EN 1452-3

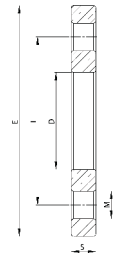

**UPVC Flange**  
 ASTM

inch	Code	DN	E	I	D	M (metric)	S	Box
1½"	1331005ASTM	40	150	110	63,5	M16	16	70
2"	1331006ASTM	50	167	127	78,5	M18	17,5	60
3"	1331008ASTM	80	202	163	110	M16	22	40
4"	1331009ASTM	100	222	182	131,5	M16	22	25
5"	1331011ASTM	125	251	211,5	167	M18	24,5	14
6"	1331012ASTM	150	285	241	191	M18	28	16
7"	1331013ASTM	175	347	296	227	M22	36	8
8"	1331014ASTM	200	341	296	251	22	36	8



**UPVC Union**  
 Solvent Cement - ASTM

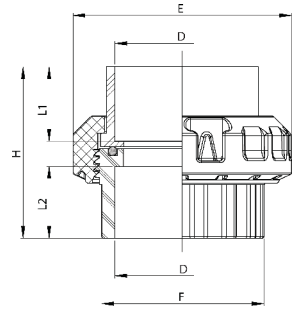

inch	Code	D	E	F	H	L1	L2	PN	Box
1"	132113ASTM	33,4	64,5	42	55	23,5	22	16	100
1½"	132115ASTM	48,3	88	61	75	32	32	16	50
2"	132116ASTM	60,33	100	88	85	37	39	16	40
3"	132118ASTM	88,9	143	109	108,5	42	48	16	30



**UPVC Union**  
 Solvent Cement x Female Threaded - ASTM

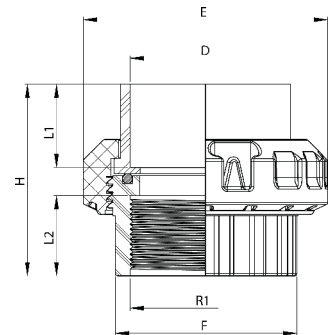

inch	Code	D	E	F	R1	H	L1	L2	PN	Box
1"	132113T1ASTM	33,4	64,5	42	1"	55	23,5	22	16	100
1½"	132115T1ASTM	48,3	88	61	1½"	75	32	32	16	50
2"	132116T1ASTM	60,33	100	88	2"	85	37	39	16	40
3"	132118T1ASTM	88,9	143	109	3"	108,5	42	48	16	30



One side BSP Standard female threaded brass.

**UPVC Union**  
 Solvent Cement x Female Brass Threaded - ASTM

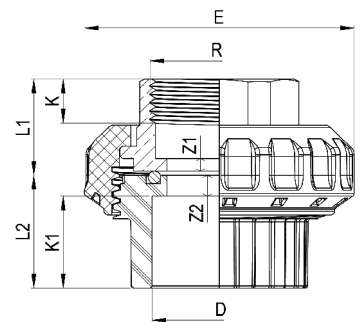

inch	Code	D	E	R1	L1	L2	Z1	Z2	K	K1	PN
1"	133462ASTM	33,4	64,5	1"	25	32	3	11	21	22	16
1½"	133464ASTM	48,3	88	1½"	34	45	3	14	31	32	16
2"	133465ASTM	60,33	100	2"	41	55	3	24	31	39	16
3"	133467ASTM	88,9	143	3"	42	48	3	24	31	48	16



One side BSP Standard male threaded brass.

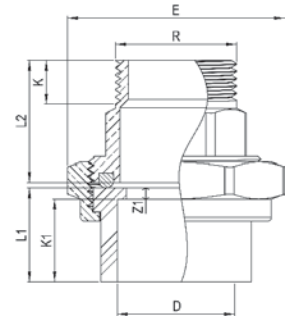

**UPVC Union**  
Male Brass Threaded x Solvent Cement - ASTM

inch	Code	D	E	R	L1	L2	Z1	K	K1	PN
1"	133472ASTM	33.4	51	1"	25	33	3	21	22	16
1½"	133474ASTM	48.3	80	1½"	34	39	3	31	31	16
2"	133475ASTM	60,3	98	2"	41	40	3	31	38	16
3"	133477ASTM	88,9	122	3"	58	70	3	35	52	16



One side BSP Standard female threaded brass.

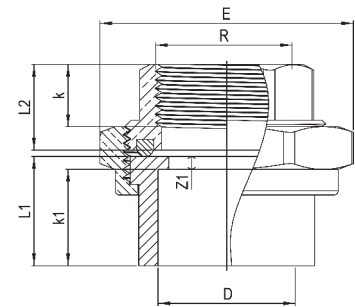

**Brass Union**  
Female Threaded x Solvent Cement - ASTM

inch	Code	D	E	R	L1	L2	Z1	K	K1	PN
1"	133452ASTM	33.4	51	1"	25	32	3	21	22	16
1½"	133454ASTM	48.3	80	1½"	34	45	3	31	31	16
2"	133455ASTM	60,3	98	2"	41	55	3	31	38	16
3"	133457ASTM	88,9	122	3"	58	64	3	35	52	16

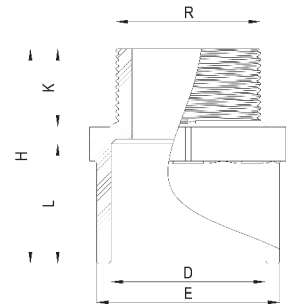

**Reducing Male Threaded Adaptor**  
ASTM

inch	Code	D	E	H	L	K	R	PN	Box
1"	133503ASTM	33.4	39	49	23	21	1"	16	300
1½"	133505ASTM	48.3	63	77	43	30	1½"	16	156
2"	133506ASTM	60,3	75	88	51	32	2"	16	96
3"	133508ASTM	88,9	110	110	73	31	3"	16	57

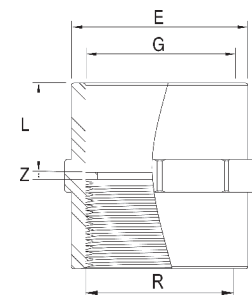

**Female Threaded Adaptor**  
ASTM

inch	Code	G	E	R	Z	L	PN	Box
1"	133404ASTM	33.4	39	1"	3	22	16	300
1½"	133405ASTM	48.3	63	1½"	3	28	16	120
2"	133406ASTM	60,3	75	2"	3	38	16	75
3"	133408ASTM	88,9	110	3"	3	51	16	57



**TECHNICAL  
MATERIALS**



This specialized solvent cements features a thixotropic formula, designed for the robust welding of rigid UPVC pipes and fittings in high-pressure systems up to PN 16. It conforms to stringent European standards including **EN 14814**, **EN 1452**, and **EN 1329**.

The gel consistency and high apparent viscosity prevent dripping and ensure easy, clean application, even on large diameters and vertical joints.

**FITVALF SOLVENT CEMENT** acts as a genuine chemical solvent, creating highly resistant, leak-free fixed joints. It is suitable for applications involving drinking water, swimming pools, and water treatment systems.

It allows for gap filling up to the adhesive cures rapidly, with a recommended 24-hour waiting time before performing pressure tests.

- 2 different color, viscosity and Solvent(THF) Content Options

## UPVC Solvent Cements

Plastic bottle with brush, medium duty formula,

Code	Description	Color	Net fillingg	Viscosity	Box
13525	Fitvalf Solvent Cement - Plastic Pot with Brush	Transparent	1000 ml	6500 cp	6
13527	Fitvalf Solvent Cement - Plastic Pot with Brush	Transparent	500 ml	6500 cp	12
13529	Fitvalf Solvent Cement - Plastic Pot with Brush	Transparent	250 ml	6500 cp	24
13537	Fitvalf Solvent Cement - Plastic Pot with Brush	Transparent	125 ml	6500 cp	48
13580	Fitvalf Solvent Cement - Aluminium Tube	Transparent	125 ml	6500 cp	30



Same as above, THF free formula, higher viscosity and gray color.

Code	Description	Color	Net fillingg	Viscosity	Box
13565	Fitvalf Solvent Cement - Plastic Pot with Brush	Gray	1000 ml	9000 cp	6
13567	Fitvalf Solvent Cement - Plastic Pot with Brush	Gray	500 ml	9000 cp	12
13568	Fitvalf Solvent Cement - Plastic Pot with Brush	Gray	250 ml	9000 cp	24



Heavy body formulation delivers superior gap filling capacity between pipe & fittings. For pipe sizes with interference fit through 12" all classes and schedules. For use on non-pressure applications through 18". All pots are with brush applicator. Please ask price for pots without brush.

UPVC pipe and fitting applications : potable water, pressure, non-pressure, conduit, drain, duct, DWV and sewer.

## UPVC Pipe Cement

Code	Description	Color	Net fillingg	Box
13570	UPVC Pipe Cement	Transparent	974 ml	12



For cleaning and degreasing piping, sleeves and fittings made of (rigid) UPVC and ABS. Also suitable for removing uncured adhesive residue and for cleaning brushes and tools.

## UPVC/ABS Cleaner

Code	Description	Color	Net Filling	Package
13541	UPVC / ABS Cleaner	Transparent	100 ml	6
13542	UPVC / ABS Cleaner	Transparent	250 ml	24
13543	UPVC / ABS Cleaner	Transparent	500 ml	12
13544	UPVC / ABS Cleaner	Transparent	1000 ml	6

# APPLICATION

**1**

Measure the length of the pipe and mark this with a permanent marker.

**2**

Saw off the pipe at a right angle to the correct length with a PVC saw or use the Cable saw for places that are difficult to reach.

**3**

Chamfer the end of the pipe ( $x=15$ ) with a chamfering tool. For diameters  $\leq 63$  mm. This is done to ensure a better distribution of the cement, to prevent scrapping away the cement and to create a locating edge for easier assembly.

**4**

Deburr the inside of the end of the pipe with the Deburring tool. This ensures that the pipe end is smooth and whole.

**5**

Mark the insertion depth (the bonding surface) on the pipe. This is important so that excess adhesive is not applied to the pipe, which can corrode the pipe and weaken the joint.

**6**

Mark the correct assembly position of the fitting. Once the joint is made, it cannot be adjusted.

**7**

Clean the inside of the fitting with fitvalf Cleaner and the Cleaner Cloth (lint-free cloth). Cleaning ensures a dirt- and grease-free surface and also provides a chemical pretreatment (pre-soak) for a better bonding. Let the parts dry properly to reduce the chance of condensation.

**8**

Clean the outside of the pipe with Fitvalf Cleaner and the Cleaner Cloth (lint-free cloth).

**9**

Apply the cement to the fitting using the special brush (integrated in the cap). The brush which is most suitable for the pipe diameter should be used. Apply a thin layer in the fitting and a somewhat thicker layer to the pipe end. Do not use too much of the cement.

**10**

Apply the cement to the pipe. This sequence (steps 9 & 10) is important because the pipe must otherwise be laid on the (dirty) ground once again.

**11**

Assemble the joint immediately in a flowing, even movement. For a good joint, an even closed ring of cement is now visible at the transition from the pipe to the fitting.

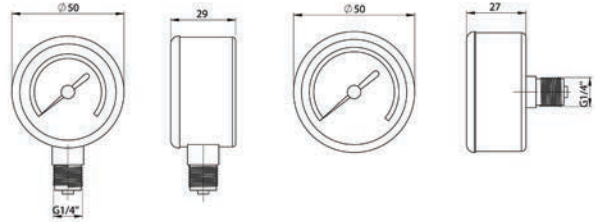

**12**

Remove superfluous cement immediately with the Griffon Cleaner Cloth. Superfluous cement can corrode the pipe and thus weaken it.

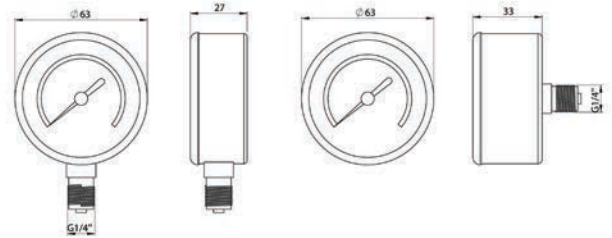

**Pressure Gauge**  
50 mm - 1/4" BSP connection

Code	Filling	Range(Bar)	Connection	Body Material
021000045	Dry	3	Bottom	Plastic
021000046	Dry	3	Rear	Plastic
021000047	Glycerine filled	3	Bottom	SS304
021000048	Dry	6	Bottom	Plastic
021000049	Glycerine filled	6	Bottom	SS304
021000050	Dry	10	Bottom	Plastic
021000051	Glycerine filled	10	Bottom	SS304



**Pressure Gauge**  
63 mm - 1/4" BSP connection

Code	Filling	Range(Bar)	Connection	Body Material
021000052	Dry	6	Bottom	Plastic
021000053	Dry	6	Rear	Plastic
021000054	Glycerine filled	6	Bottom	SS304
021000055	Glycerine filled	6	Rear	SS304
021000056	Dry	10	Bottom	Plastic
021000057	Dry	10	Rear	Plastic
021000058	Glycerine filled	10	Bottom	SS304
021000059	Glycerine filled	10	Rear	SS304
021000060	Dry	16	Bottom	Plastic
021000061	Dry	16	Rear	Plastic
021000062	Glycerine filled	16	Bottom	SS304
021000064	Glycerine filled	16	Rear	SS304
021000065	Glycerine filled	25	Bottom	SS304
021000066	Glycerine filled	25	Rear	SS304

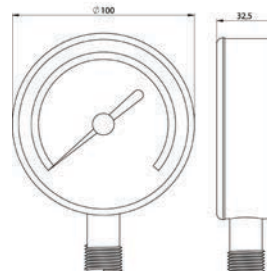

**Pressure Gauge**  
100 mm - 1/2" BSP connection

Code	Filling	Range(Bar)	Connection	Body Material
021000067	Dry	6	Bottom	SS304
021000068	Dry	10	Bottom	SS304
021000069	Dry	16	Bottom	SS304
021000070	Dry	25	bottom	SS304



Taper tube from AS.  
 Connections UPVC.  
 Leader from AISI 316 SS.  
 Float from ABS.  
 PN6. Accuracy:  $\pm 4\%$

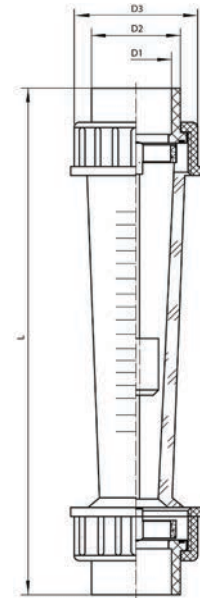

**Mechanical Flowmeter**  
 Solvent Cement

D	DN	Code	Range	L	D2	D3
32	25	13LZS25	250-2500 L/h	226	39	60
40	32	13LZS32	1-10 m <sup>3</sup> /h	288	50	79
50	40	13LZS40	1-10 m <sup>3</sup> /h	430	63	88
63	50	13LZS50	1,6-16 m <sup>3</sup> /h	341	73	98
75	65	13LZS65	8-40 m <sup>3</sup> /h	430	88	122



Taper tube from AS.  
 Flange DIN8063 connections UPVC.  
 Leader from AISI 316 SS.  
 Float from ABS.  
 PN6. Accuracy:  $\pm 4\%$

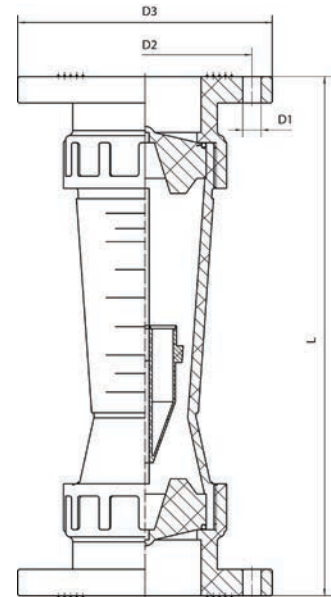

**Mechanical Flowmeter**  
 Flanged

D	DN	Code	Range	L	D2	D3
90	80	13LZS80	12-60 m <sup>3</sup> /h	540	160	200
110	100	13LZS100	18-120 m <sup>3</sup> /h	510	180	215
125	125	13LZS125	20-150 m <sup>3</sup> /h	510	210	250
160	150	13LZS150	25-250 m <sup>3</sup> /h	510	240	280



# FILTRATION PRODUCTS



AISI 304 quality stainless steel pre-filter.  
Lid with washer and nuts.  
Connections with loose flange.  
4 mm mesh size.

## Pump Pre-Filters Stainless Steel

Description	Code	Box	Weight (kg)
5"	01312	1	15,000
6"	01313	1	17,350
8"	01314	1	19,450



Fiberglass Reinforced PP Body.  
20 l and 40 l capacity.  
PP basket. Polycarbonate transparent lid.  
4 mm mesh size.

## Pump Pre-Filters Injected Thermoplastic

Description	Code	Box	Weight (kg)
4" - Unions	013311	1	9,740
5" - Flanged	013321	1	10,750
Stainless Steel Pre-filterBasket AISI 304 Quality	0111FL01	1	12,750
6"	013331	1	25,300



Fiberglass reinforced polyester body pre-filter.  
Plastic pre-filter basket, transparent acrylic lid, loose flange.

## Pump Pre-Filters Fiberglass Reinforced Polyester

Description	Code	Box	Weight (kg)
4"-4,5" Suitable for Flooder Pump	013209	1	15,000
4"	013210	1	17,350
6"	013323	1	19,450



Loose flange connection and 20 l capacity.  
Pipe connections can be produced according to demand.  
The basket and opening mechanism are made of stainless steel.  
Transparent acrylic lid.  
Can be used up to 160 mm connections.

## Pump Pre-Filters Fiberglass Reinforced Polyester

Description	Code	Box	Weight (kg)
4"	013211	1	16,700
5"	013212	1	16,700
6"	013213	1	16700



Up to size Ø1800, filter shell made of single piece Roto MOLDED PE.  
 Larger sizes shell made of FR Polyester shell reinforced by fiberglass bobbin winding outside. Complete with pressure gauge, air release valve.  
 Test pressure 4,0 kg/cm<sup>2</sup>.  
 Max. operation pressure 2,5 kg/cm<sup>2</sup>. Filtration rate: 40 m<sup>3</sup>/h/m<sup>2</sup>.  
 Filtration bed depth:1,0 m (Excluding 021717E, 021725 and 021718).  
 Please check option table to order a particular design.

 **Turbidron**  
 Bobin Wound Filter

Description	Code	Box	Weight (kg)
Ø1200 mm - 56 m <sup>3</sup> /h, 75 mm unions	021717E	1	95,000
Ø1200 mm - 56 m <sup>3</sup> /h	021725	1	110,000
Ø1400 mm - 77 m <sup>3</sup> /h	021718	1	180,000
Ø1600 mm - 100 m <sup>3</sup> /h	021719	1	240,000
Ø1800 mm - 127 m <sup>3</sup> /h	021720	1	275,000
Ø2000 mm - 157 m <sup>3</sup> /h	021721	1	300,000
Ø2200 mm - 190 m <sup>3</sup> /h	021722	1	425,000
Ø2350 mm - 217 m <sup>3</sup> /h	021727	1	500,000
Ø2400 mm - 226 m <sup>3</sup> /h	021723	1	535,000
Ø2500 mm - 245 m <sup>3</sup> /h	021724	1	-
Ø3000 mm - 245 m <sup>3</sup> /h	021726	1	-



**Technical Characteristics**

	021717E	021725	021718	021719	021720	021721	021722	021727	021723	021724	021726
D (mm)	1200	1200	1400	1600	1800	2000	2200	2350	2400	2500	3000
H1 (mm)	1410	1410	1560	1860	1890	2000	2160	2300	2300	2450	2770
H3 (mm)	1350	1350	1500	1800	1830	1940	2100	2240	2240	2390	2710
H4 (mm)	520	520	600	640	670	740	800	850	850	900	
H5 (mm)	880	880	950	1200	1170	1240	1300	1450	1450	1550	
Ø (mm)	75	90	110	125	140	160	200	200	200	200	200
Flow (m3/h)	56	56	77	100	127	157	190	217	226	245	245
Sand (Kg)	1100	1100	1750	2800	3200	4200	5600	7600	8000	8600	7000
Net Weight (Kg)	95,000	110,000	180,000	240,000	275,000	300,000	425,000	500,000	535,000	-	-



## Turbidron Commercial Sand Filters Design Options

DESCRIPTION	Bed Depth 1.0 m Lateral Distribution	Bed Depth 1.20 m	Nozzle plate distribution system	Circular Manhole 2,5 Bar Ø400 mm	Circular Manhole 2,5 Bar Ø500 mm	Circular Manhole 2,5 Bar Ø600 mm	Sight Glass 2,5 Bar Ø90 mm	Sight Glass 2,5 Bar Ø125 mm	Sight Glass 2,5 Bar Ø200 mm	Sight Glass 2,5 Bar Ø250 mm	Automatic Air Purge 1"	Automatic Air Purge 2"	Double Manometer Set	Ozon Protection
X Operation Pressure Max. 2,5 kg/cm Test Pressure 4 kg/cm Filtration Speed 40 m <sup>3</sup> /h/m <sup>2</sup>	A	B	C	D	N	E	F	G	H	I	J	K	L	M
1 Filter Ø1200 mm - 45 m <sup>3</sup> /h	P.A.P.	P.A.P.	P.A.P.	P.A.P.	P.A.P.	P.A.P.	P.A.P.	P.A.P.	P.A.P.	P.A.P.	P.A.P.	P.A.P.	P.A.P.	P.A.P.
2 Filter Ø1400 mm - 62 m <sup>3</sup> /h	P.A.P.	P.A.P.	P.A.P.	P.A.P.	P.A.P.	P.A.P.	P.A.P.	P.A.P.	P.A.P.	P.A.P.	P.A.P.	P.A.P.	P.A.P.	P.A.P.
3 Filter Ø1600 mm - 80 m <sup>3</sup> /h	P.A.P.	P.A.P.	P.A.P.	P.A.P.	P.A.P.	P.A.P.	P.A.P.	P.A.P.	P.A.P.	P.A.P.	P.A.P.	P.A.P.	P.A.P.	P.A.P.
4 Filter Ø1800 mm - 100 m <sup>3</sup> /h	P.A.P.	P.A.P.	P.A.P.	P.A.P.	P.A.P.	P.A.P.	P.A.P.	P.A.P.	P.A.P.	P.A.P.	P.A.P.	P.A.P.	P.A.P.	P.A.P.
5 Filter Ø2000 mm - 125 m <sup>3</sup> /h	P.A.P.	P.A.P.	P.A.P.	P.A.P.	P.A.P.	P.A.P.	P.A.P.	P.A.P.	P.A.P.	P.A.P.	P.A.P.	P.A.P.	P.A.P.	P.A.P.
6 Filter Ø2200 mm - 152 m <sup>3</sup> /h	P.A.P.	P.A.P.	P.A.P.	P.A.P.	P.A.P.	P.A.P.	P.A.P.	P.A.P.	P.A.P.	P.A.P.	P.A.P.	P.A.P.	P.A.P.	P.A.P.
7 Filter Ø2350 mm - 173 m <sup>3</sup> /h	P.A.P.	P.A.P.	P.A.P.	P.A.P.	P.A.P.	P.A.P.	P.A.P.	P.A.P.	P.A.P.	P.A.P.	P.A.P.	P.A.P.	P.A.P.	P.A.P.
8 Filter Ø2500 mm - 196 m <sup>3</sup> /h	P.A.P.	P.A.P.	P.A.P.	P.A.P.	P.A.P.	P.A.P.	P.A.P.	P.A.P.	P.A.P.	P.A.P.	P.A.P.	P.A.P.	P.A.P.	P.A.P.
9 Filter Ø3000 mm - 283 m <sup>3</sup> /h	P.A.P.	P.A.P.	P.A.P.	P.A.P.	P.A.P.	P.A.P.	P.A.P.	P.A.P.	P.A.P.	P.A.P.	P.A.P.	P.A.P.	P.A.P.	P.A.P.
DESCRIPTION	Bed Depth 1.0 m Lateral Distribution	Bed Depth 1.20 m	Nozzle plate distribution system	Circular Manhole 4 Bar Ø400 mm	Circular Manhole 4 Bar Ø500 mm	Circular Manhole 4 Bar Ø600 mm	Sight Glass 4 Bar Ø90 mm	Sight Glass 4 Bar Ø125 mm	Sight Glass 4 Bar Ø200 mm	Sight Glass 4 Bar Ø250 mm	Automatic Air Purge 1"	Automatic Air Purge 2"	Double Manometer Set	Ozon Protection
Y Operation Pressure Max. 4 kg/cm Test Pressure 6 kg/cm Filtration Speed 40 m <sup>3</sup> /h/m <sup>2</sup>	A	B	C	D	N	E	F	G	H	I	J	K	L	M
1 Filter Ø1200 mm - 45 m <sup>3</sup> /h	P.A.P.	P.A.P.	P.A.P.	P.A.P.	P.A.P.	P.A.P.	P.A.P.	P.A.P.	P.A.P.	P.A.P.	P.A.P.	P.A.P.	P.A.P.	P.A.P.
2 Filter Ø1400 mm - 62 m <sup>3</sup> /h	P.A.P.	P.A.P.	P.A.P.	P.A.P.	P.A.P.	P.A.P.	P.A.P.	P.A.P.	P.A.P.	P.A.P.	P.A.P.	P.A.P.	P.A.P.	P.A.P.
3 Filter Ø1600 mm - 80 m <sup>3</sup> /h	P.A.P.	P.A.P.	P.A.P.	P.A.P.	P.A.P.	P.A.P.	P.A.P.	P.A.P.	P.A.P.	P.A.P.	P.A.P.	P.A.P.	P.A.P.	P.A.P.
4 Filter Ø1800 mm - 100 m <sup>3</sup> /h	P.A.P.	P.A.P.	P.A.P.	P.A.P.	P.A.P.	P.A.P.	P.A.P.	P.A.P.	P.A.P.	P.A.P.	P.A.P.	P.A.P.	P.A.P.	P.A.P.
5 Filter Ø2000 mm - 125 m <sup>3</sup> /h	P.A.P.	P.A.P.	P.A.P.	P.A.P.	P.A.P.	P.A.P.	P.A.P.	P.A.P.	P.A.P.	P.A.P.	P.A.P.	P.A.P.	P.A.P.	P.A.P.
6 Filter Ø2200 mm - 152 m <sup>3</sup> /h	P.A.P.	P.A.P.	P.A.P.	P.A.P.	P.A.P.	P.A.P.	P.A.P.	P.A.P.	P.A.P.	P.A.P.	P.A.P.	P.A.P.	P.A.P.	P.A.P.
7 Filter Ø2350 mm - 173 m <sup>3</sup> /h	P.A.P.	P.A.P.	P.A.P.	P.A.P.	P.A.P.	P.A.P.	P.A.P.	P.A.P.	P.A.P.	P.A.P.	P.A.P.	P.A.P.	P.A.P.	P.A.P.
8 Filter Ø2500 mm - 196 m <sup>3</sup> /h	P.A.P.	P.A.P.	P.A.P.	P.A.P.	P.A.P.	P.A.P.	P.A.P.	P.A.P.	P.A.P.	P.A.P.	P.A.P.	P.A.P.	P.A.P.	P.A.P.
9 Filter Ø3000 mm - 283 m <sup>3</sup> /h	P.A.P.	P.A.P.	P.A.P.	P.A.P.	P.A.P.	P.A.P.	P.A.P.	P.A.P.	P.A.P.	P.A.P.	P.A.P.	P.A.P.	P.A.P.	P.A.P.

NOTE: Please generate the product code number as per filter option configuration. (i.e X1B for d1200 Sand filter, 2,5 bar working pressure , 1,20 Sand Depth)



### GEMAS GLASS FILTER-MEDIA

An environmentally friendly alternative to silica sand for filtration purposes. It is made from recycled glass, eliminating the need for intrusive mining and reducing the consumption of scarce resources.

#### GGFM offers several benefits over silica sand:

**Improved Efficiency:** Due to its angular to sub-angular particle shape and bound silica content, GGFM provides a 30% improvement in turbidity removal compared to silica sand. It also has the ability to remove finer particles from water.

**Reduced Backwashing:** The non-porous composition of GGFM prevents it from clumping, resulting in reduced backwashing needs. This leads to water, energy, and chemical treatment cost savings.

**Cleaner Performance:** GGFM's smooth surface area makes it less susceptible to bio-fouling compared to silica sand. Bacteria are unable to get trapped in cracks or flaws, reducing the need for remedial action and chemical treatment to combat pollutants.

**Lower Material Requirement:** GGFM is less dense than sand, requiring 15% less media to fill an equivalent filter.

**Longer Lifespan:** GGFM's durability translates to a longer lifespan, potentially eliminating the need for media replacement during filter refurbishment.

Overall, GEMAS GLASS FILTER-MEDIA offers superior performance, cost-effectiveness, and environmental advantages compared to traditional silica sand. It contributes to efficient filtration, reduced maintenance, and a longer-lasting filtration system.

## Glass Filtration Media

Description	Code
0,6 mm - 1,00 mm grain thickness - 25 kg	023411
1 mm - 3,00 mm grain thickness - 25 kg	023412
3 mm - 5,00 mm grain thickness - 25 kg	023413

### Density Comparison GGFM Against Sand

Dia of Filter (mm)	Total Grade 1&3 Sand Required (kg)	Total Grade 1&3 GGFM Required (kg)
600	150	130
750	250	215
900	450	385
1000	700	595
1200	1300	1100
1400	1950	1660
1600	2750	2340
1800	3650	3105
2000	4750	4040
2200	5700	4845
2400	6600	5610
2500	7000	5950



Polymer Filtration Media - PFM: Synthetic Filtration Media made of polymer, can be used instead of quartz sand for commercial or domestic sand filters. Its being lightweight is a great advantage during the application.

Backwash can be done as usual. But as pressure increase is low inside the polluted filter, backwash should be done with timing (The longest backwash period once in a week). It gives opportunity to get the required flow rate rate with a smaller pump, as pressure loss is low.

1 bag of PFM is 500 gr and it's equal to 25 kg sand. Can also be used inside cartridge filters. It filters 1 micron particles and yet not flocculant is required with PFM.

## Polymer Filtration Media

Description	Code
PFM Bag	02351



### Highly Effective filtering Process

SiLibeads® have outstanding filtration properties owing to their consistent geometrical shape which results in a homogenous filter bed. Suspended particles are completely removed during the backwashing process and the filter material will stay as clean and efficient as the day it was installed.

### Crystal clear, hygienic water

The special surface properties of the refined SiLibeads® prevent any accumulation of bacteria, fungi, algae and calcifications.

### Economics

Filters using SiLibeads® can absorb up to 25 % more particles resulting in longer intervals between cleanings. Additionally, SiLibeads® allow for shortened rinsing periods at lower speeds resulting in water and energy savings.

### Reduces the use of chemical agents

SiLibeads® suppress the formation of biofilm and prevent unwanted contamination of the filter. The cleaning agents therefore work with greater efficacy where they are needed – in the water and not in the filter.

The costs for chemical agents are significantly reduced.



#### SAVE ENERGY

Longer time between backwash cycles



#### REDUCTION OF CHEMICAL AGENTS

Lower chlorine oxidation demand



#### OPTIMIZED FILTER BED

Stable filtration performance



#### LOW RISK OF BIOFILM

Smooth surface prevents biofouling



#### LONG-LASTING DURABILITY

High crushing strength through high density



#### SAVE BACKWASH WATER

Up to 40% less water



## SiLibeads

Description	Code
0.5 mm - 1 mm grain thickness - 25 kg	023511
0.4mm - 1.2 mm grain thickness - 25 kg	023512
1.2mm - 5 mm grain thickness - 25 kg	023513

Sand

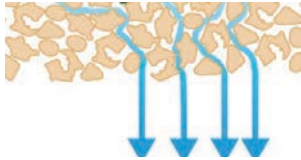

- Amorphous, uneven shape
- Porous to very porous surface
- High abrasion, excessive wear
- high dust content (undersize, zero grain)

Glass Granules

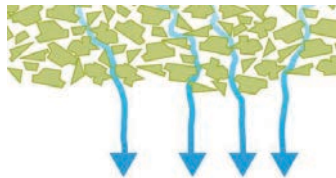

- Amorphous, uneven shape
- Smooth, sometimes sharp-edged surface
- Higher material hardness and surface quality
- Abrasion and water caused by sharp edges
- High dust content (undersize, zero grain)

SiLibeads

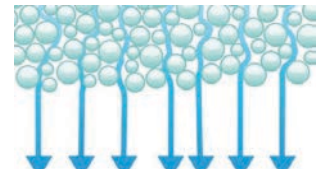

- Even, geometric shape
- Smooth, closed surface
- High material hardness and surface quality
- Minimal abrasion and lowest wear
- Absolutely no dust content



The Streamer Pumps are precision, injection - moulded units, using a temperature and corrosion resistant fibre glass low dense plastic. The difference between Streamer 2010 and other pumps lies in their incomparable performance.

**Characteristics**

Monoblock pump body, in 30% GFPP for protection against corrosive water. Housed inside is a PREFILTERING BASKET in TWO PARTS that has a large filtering surface and is easy to remove and to clean. High quality steel shaft and mechanical seal. Noryl ultrasound soldered impeller.

**Motor**

IP55 protected. 230V or 230/400V - 50Hz. 2850 rpm.

## Fitvalf Streamer 2010

Description	Code	Pieces	Weight (kg)	Volume(m <sup>3</sup> )
STRN-50M 1/2 HP, Monophase	0111STRN50M	1	11.514	0.051
STRN-80M 3/4 HP, Monophase	0111STRN75M	1	12.484	0.051
STRN-80T 3/4 HP, Triphase	0111STRN75T	1	11.754	0.051
STRN-100M 1 HP, Monophase	0111STRN100M	1	13.609	0.051
STRN-100T 1 HP, Triphase	0111STRN100T	1	12.244	0.051
STRN-150M 1,5 HP, Monophase	0111STRN150M	1	16.344	0.051
STRN-150T 1,5 HP, Triphase	0111STRN150T	1	15.669	0.051
STRN-200M 2,0 HP, Monophase	0111STRN200M	1	18.404	0.051
STRN-200T 2,0 HP, Triphase	0111STRN200T	1	17.534	0.051
STRN-300M 3,0 HP, Monophase	0111STRN300M	1	18.404	0.051
STRN-300T 3,0 HP, Triphase	0111STRN300T	1	17.534	0.051
STRN-350M 3,5 HP, Monophase	0111STRN350M	1	21.704	0.054
STRN-350T 3,5 HP, Triphase	0111STRN350T	1	20.384	0.054

PERFORMANCE CURVES

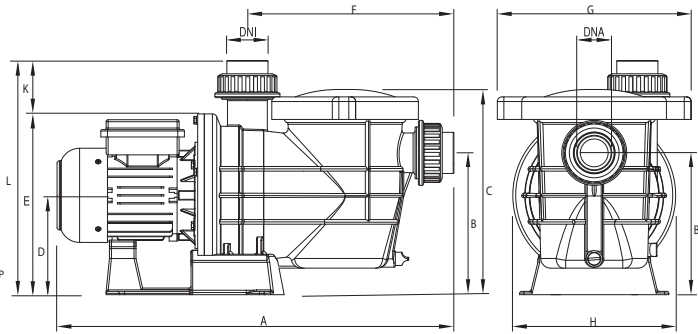
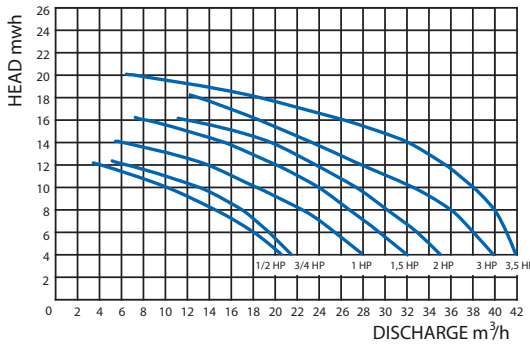

Pump Type	HP	CON-DAN-SATOR (µF)	Amperes			HEAD mwh								
			II	III	400V	4	6	8	10	12	14	16	18	20
			230V	230V	400V	DISCHARGE m <sup>3</sup> /h								
STRN-50M/T	0,50	16	2,73	-	-	20,50	18,00	14,30	10,00	4,00	-	-	-	-
STRN-75M/T	0,75	20	3,88	2,33	1,35	21,70	19,50	17,00	13,00	6,00	-	-	-	-
STRN-100M/T	1,00	25	5,15	3,03	1,75	28,00	25,70	22,50	18,00	13,90	6,00	-	-	-
STRN-150M/T	1,50	30	7,02	4,42	2,55	32,00	29,70	26,50	24,00	20,00	15,50	8,00	-	-
STRN-200M/T	2,00	40	8,60	5,50	3,50	35,00	33,00	30,00	27,50	23,80	19,50	12,00	-	-
STRN-300M/T	3,00	40	9,80	6,01	3,90	40,00	38,00	36,00	32,40	27,60	23,20	18,50	13,00	-
STRN-350M/T	3,50	60	13,67	8,61	4,98	42,00	41,00	40,00	38,00	35,50	32,00	26,40	18,50	7,10

Pump Type	DIMENSION (mm)												Net Weight(kg)		Packing W. (kg)	
	DNA	DNI	A	K	B	C	D	E	F	G	H	L	Mo.	Tri.	Mo.	Tri.
STRN-50M/T	1½"	1½"	610	80	205	310	145	275	320	292	245	355	10,290	-	11,514	-
STRN-75M/T	2"	1½"	610	80	205	310	145	275	320	292	245	355	11,234	-	12,484	-
STRN-100M/T	2"	1½"	610	80	205	310	145	275	320	292	245	355	12,360	11,000	13,609	12,244
STRN-150M/T	2"	2"	630	80	205	310	145	275	320	292	245	355	15,095	14,420	16,344	15,669
STRN-200M/T	2"	2"	630	80	205	310	145	275	320	292	245	355	17,150	16,280	17,534	18,404
STRN-300M/T	2"	2"	630	80	205	310	145	275	320	292	245	355	17,150	16,280	17,534	18,404
STRN-350M/T	2"	2"	670	80	205	310	145	275	320	292	245	355	20,450	19,130	20,384	21,704

Pump Type	STRN-50T/M	STRN-75T/M	STRN-100T/M	STRN-150T/M	STRN-200T/M	STRN-300T/M	STRN-350T/M
Ø SUCTION PIPE	1½" (Ø50mm)	2" (Ø63mm)	2" (Ø63mm)	2½" (Ø75mm)	3" (Ø90mm)	3" (Ø90mm)	4" (Ø110mm)



Self-priming, thermoplastic body Monoblock Pool Pump; Complete with pre-filter. Up to 1 1/2 HP, Suction 1 1/2". Discharge 2"; bigger sizes both 2". Connections are with unions. Easy opening lid with 40° turning. "Xylex" lid option against aggressive chemicals. Larger basket. 2850 rpm - IP 55

**Motor.**

Pump shaft in AISI 316 quality stainless steel.

## Fitvalf Pumpex 2010

Description	Code	Pieces	Weight (kg)	Volume(m <sup>3</sup> )
PUMPEX-50M 0,50 HP, Monophase	0111PX50M	1	19.12	0.096
PUMPEX-75M 0,75 HP, Monophase	0111PX75M	1	20.32	0.096
PUMPEX-75T 0,75 HP, Triphase	0111PX75T	1	19.12	0.096
PUMPEX-100M 1 HP, Monophase	0111PX100M	1	20.32	0.096
PUMPEX-100T 1 HP, Triphase	0111PX100T	1	19.12	0.096
PUMPEX-150M 1,5 HP, Monophase	0111PX150M	1	20.12	0.096
PUMPEX-150T 1,5 HP, Triphase	0111PX150T	1	21.12	0.096
PUMPEX-200M 2 HP, Monophase	0111PX200M	1	25.12	0.096
PUMPEX-200T 2 HP, Triphase	0111PX200T	1	23.12	0.096
PUMPEX-300M 3 HP, Monophase	0111PX300M	1	26.12	0.096
PUMPEX-300T 3 HP, Triphase	0111PX300T	1	26.12	0.096

PERFORMANCE CURVES

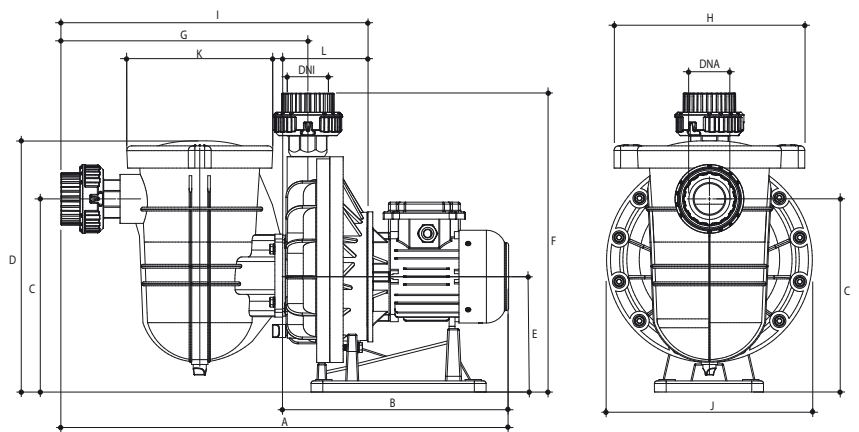
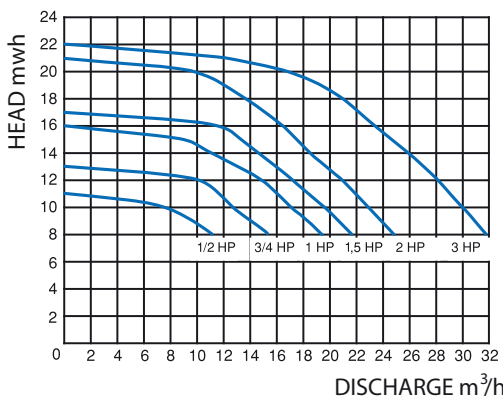

Pump Type	HP	CON-DAN-SATOR (µF)	Amperes			HEAD mwh								
			II	III		8	10	12	14	15	16	18	20	
			230V	230V	380V	DISCHARGE m <sup>3</sup> /h								
PX-50M	0,50	13	2,60			11,14	7,25	-	-	-	-	-	-	-
PX-75T/M	0,75	20	3,80	3,70	-	15,33	12,64	10,00	-	-	-	-	-	-
PX-100T/M	1,00	25	4,95	3,11	1,80	19,43	17,00	14,84	11,00	8,89	-	-	-	-
PX-150T/M	1,50	30	7,80	4,41	2,55	21,65	19,47	17,12	14,57	13,30	11,36	-	-	-
PX-200T/M	2,00	40	9,90	5,88	3,40	24,80	22,90	20,90	18,40	17,50	16,40	13,60	9,60	-
PX-300T/M	3,00	40	-	8,00	4,90	32,00	30,00	28,00	26,00	25,00	23,50	21,00	17,00	-

Pump Type	DIMENSION (mm)														Net Weight(kg)	
	DNA	DNI	A	B	C	D	E	F	G	I	H	J	K	L	Mo.	Tri.
PX-50M	2"	1½"	715	375	295	384	176	460	382	480	292	315	223	135	16,500	-
PX-75T/M	2"	1½"	715	375	295	384	176	460	382	480	292	315	223	135	17,420	-
PX-100T/M	2"	1½"	715	375	295	384	176	460	382	480	292	315	223	135	18,620	17,420
PX-150T/M	2"	1½"	735	395	295	384	176	460	382	480	292	315	223	135	18,520	19,420
PX-200T/M	2"	1½"	735	395	295	384	176	460	382	480	292	315	223	135	23,420	21,420
PX-300T/M	2"	1½"	735	395	295	384	176	460	382	480	292	315	223	135	24,120	24,420

Pump Type	Packing Dimensions
PX- 50 / 75 / 100 / 150 / 200 / 300	1½" (Ø50m 660 x 340 x 390 m)



Self-priming, thermoplastic body Monoblock Pool Pump  
 Suction 1 1/2". Discharge 2"  
 Without pre-filter. Complete with connection unions.  
 IP 55 Motor.  
 Pump shaft in AISI 316 quality stainless steel.

## Fitvalf Pumpex Jet

Description	Code	Pieces	Weight (kg)	Volume(m <sup>3</sup> )
PUMPEXJ-50M 0,50 HP, Monophase	0111PXJ50M	1	19.12	0.096
PUMPEXJ-75M 0,75 HP, Monophase	0111PXJ75M	1	20.32	0.096
PUMPEXJ-75T 0,75 HP, Triphase	0111PXJ75T	1	19.12	0.096
PUMPEXJ-100M 1 HP, Monophase	0111PXJ100M	1	20.32	0.096
PUMPEXJ-100T 1 HP, Triphase	0111PXJ100T	1	19.12	0.096
PUMPEXJ-150M 1,5 HP, Monophase	0111PXJ150M	1	20.12	0.096
PUMPEXJ-150T 1,5 HP, Triphase	0111PXJ150T	1	21.12	0.096
PUMPEXJ-200M 2 HP, Monophase	0111PXJ200M	1	25.12	0.096
PUMPEXJ-200T 2 HP, Triphase	0111PXJ200T	1	23.12	0.096
PUMPEXJ-300M 3 HP, Monophase	0111PXJ300M	1	26.12	0.096
PUMPEXJ-300T 3 HP, Triphase	0111PXJ300T	1	26.12	0.096

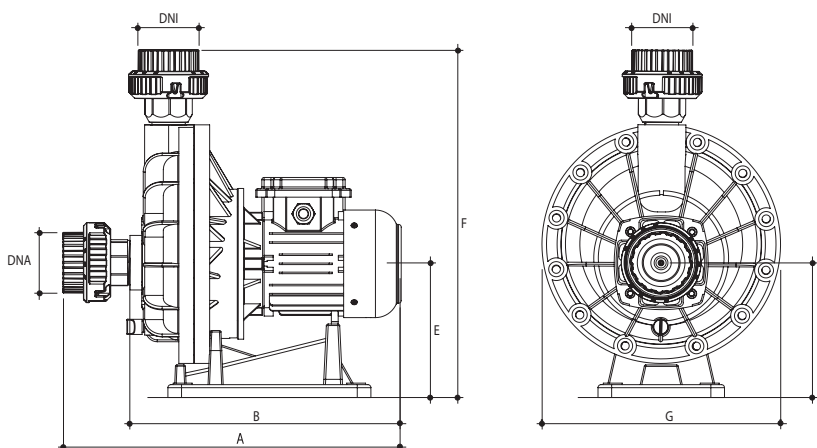
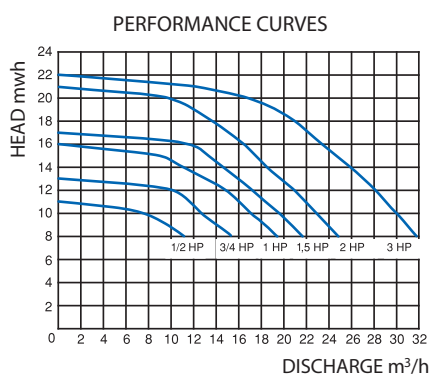

Pump Type	HP	CON-DAN-SATOR (µF)	Amperes			HEAD mwh									
			II	III		8	10	12	14	15	16	18	20		
				230V	230V	380V	DISCHARGE m <sup>3</sup> /h								
PXJ-50M	0,50	13	2,60			11,14	7,25	-	-	-	-	-	-	-	-
PXJ-75T/M	0,75	20	3,80	3,70	-	15,33	12,64	10,00	-	-	-	-	-	-	-
PXJ-100T/M	1,00	25	4,95	3,11	1,80	19,43	17,00	14,84	11,00	8,89	-	-	-	-	-
PXJ-150T/M	1,50	30	7,80	4,41	2,55	21,65	19,47	17,12	14,57	13,30	11,36	-	-	-	-
PXJ-200T/M	2,00	40	9,90	5,88	3,40	24,80	22,90	20,90	18,40	17,50	16,40	13,60	9,60	-	-
PXJ-300T/M	3,00	40	-	8,00	4,90	32,00	30,00	28,00	26,00	25,00	23,50	21,00	17,00	-	-

Pump Type	DIMENSION (mm)														Net Weight(kg)	
	DNA	DNI	A	B	C	D	E	F	G	I	H	J	K	L	Mo.	Tri.
PXJ-50M	2"	1½"	470	375	295	384	176	460	287	384	292	315	135	223	16,500	-
PXJ-75T/M	2"	1½"	470	375	295	384	176	460	287	384	292	315	135	223	17,420	-
PXJ-100T/M	2"	1½"	470	375	295	384	176	460	287	384	292	315	135	223	18,620	17,420
PXJ-150T/M	2"	1½"	490	395	295	384	176	460	287	384	292	315	135	223	18,520	19,420
PXJ-200T/M	2"	1½"	490	395	295	384	176	460	287	384	292	315	135	223	23,420	21,420
PXJ-300T/M	2"	1½"	490	395	295	384	176	460	287	384	292	315	135	223	24,120	24,420



**CERTIFICATES**

SGS



## TEST REPORT

Job No./Report No. TR 244557 DATE : January 18 2010 Page 1 of 5

**GEMAS GEENL MÜHENDİSLİK MEKANİK SAN.VE TİC.A.Ş.**  
 AYAZMA YOLU NO:11 KAGITHANE  
 ISTANBUL  
 TEL:0212 3219230  
 Fax:0212 2947735  
 Mail: deniz@gemas.com.tr  
 For the attention of Deniz hanım

The following sample(s) was/were submitted and identified by/on behalf of the clients as:

Sample Submitted By : GEMAS GEENL MÜHENDİSLİK MEKANİK SAN.VE TİC.A.Ş.  
 Sample Description : PVC Fittings  
 Model No : TEE/ Sockets /Elbow 90°  
 PO No/Ref.No : Not Given  
 Client : Not Given  
 End Use : Pool Fitting  
 Sample Receiving Date : January 10, 2011  
 Testing Period : January 10, 2011~ January 12, 2011  
 Service Type : NORMAL  
 Test Requested : Selected test (s) as requested by client.  
 Test Method : Please refer to next page(s)  
 Test Result(s) : Please refer to next page(s)  
 Conclusion : Based on the performed tests on submitted samples, the result **complies with the RoHS Directive 2002/95/EC and its subsequent amendments.**

The test results relate only to the items tested only. The report shall not be reproduced except in full, without the written approval of the laboratory. Test reports without SGS seal and authorized person signature are invalid. The reported uncertainty is based on a standard uncertainty multiplied by a coverage factor k=2, providing a level of confidence of approximately 95%, the uncertainty evaluation has been carried out in accordance with UKAS/ISO 17025 requirements. This results do not include uncertainties. Opinions and interpretations expressed herein are outside of the scope of UKAS Accreditation. Tests marked (\*) in this Test Report are not included in the UKAS Accreditation Schedule for this Laboratory.

Issued in Istanbul  
 For and on behalf of  
 SGS Supervise Gözetme Etüd Kontrol Servisleri A.Ş.

Serap Morcalı Neslihan Erol  
 Lab. Customer Services Customer Relations Supervisor  
 Coordinator



"This document is issued by the Company subject to its General Conditions of Service printed overleaf, available on request or accessible at [www.sgs.com/terms\\_and\\_conditions.htm](http://www.sgs.com/terms_and_conditions.htm) and, for electronic format documents, subject to Terms and Conditions for Electronic Documents at [www.sgs.com/terms\\_e-document.htm](http://www.sgs.com/terms_e-document.htm).

Attention is drawn to the limitation of liability, indemnification and jurisdiction issues defined therein. Any holder of this document is advised that information contained hereon reflects the Company's findings at the time of its intervention only and within the limits of Client's instructions, if any. The Company's sole responsibility is to its Client and this document does not exonerate parties to a transaction from exercising all their rights and obligations under the transaction documents. This document cannot be reproduced except in full, without prior written approval of the Company. Any unauthorized alteration, forgery or falsification of the content or appearance of this document is unlawful and offenders may be prosecuted to the fullest extent of the law.

Unless otherwise stated the results shown in this test report refer only to the sample(s) tested and such sample(s) are retained for 30 days only."

SGS Supervise Gözetme Etüd Kontrol  
 Servisleri A. Ş.

Abide-i Hüriyet Cad. Geçit Sk. No : 10 K: 1-2-3-4, Şişli 34381  
 T (90-212) 368 40 00 F (90-212) 296 47 82/83

Istanbul - Turkey  
[www.tr.sgs.com](http://www.tr.sgs.com)

Member of SGS Group (Société Générale de Surveillance)



**TÜRK STANDARDLARI ENSTİTÜSÜ**  
**TÜRK STANDARDLARINA UYGUNLUK BELGESİ**  
**TURKISH STANDARDS INSTITUTION**  
**CERTIFICATE OF CONFORMITY TO TURKISH STANDARDS**

Markanın Tanımı Description of the Mark  
**TSE** veya/ort  veya/ort **TSE**

<b>BELGE NUMARASI</b> REFERENCE NUMBER OF LICENCE	071244-TSE-01/03
<b>BELGENİN İLK VERİLİŞ TARİHİ</b> DATE OF FIRST ISSUE OF LICENCE	28.08.2014
<b>BELGENİN SON GEÇERLİLİK TARİHİ</b> LICENCE VALID UNTIL	28.08.2026
<b>BELGE SAHİBİ KURULUŞUN ADI</b> NAME OF THE LICENCE HOLDER	STAR DERİ TEKSTİL HAVUZ VE BİLİŞİM ÜRÜNLERİ SANAYİ TİCARET
<b>BELGE SAHİBİ KURULUŞUN ADRESİ</b> ADDRESS OF THE LICENCE HOLDER	10001 SOK NO 28 İDARİ BİNA ZEMİN KAT İTOB TEKELİ KÖYÜ MENDERES İZMİR/TÜRKİYE
<b>ÜRETİM YERİ ADI</b> NAME OF THE MANUFACTURING PLACE	STAR DERİ,TEKSTİL,HAVUZ ve BİLİŞİM ÜRÜNLERİ SAN TIC AŞ
<b>ÜRETİM YERİ ADRESİ</b> ADDRESS OF THE MANUFACTURING PLACE	10001 SOK NO 28 İDARİ BİNA ZEMİN KAT İTOB TEKELİ KÖYÜ MENDERES İZMİR / TÜRKİYE
<b>İPTAL EDİLEN BELGE NUMARASI (Varsa)</b> INDICATION OF SUPERSEDED LICENCE (if any)	071244-TSE-01/02
<b>TESCİLLİ TİCARİ MARKASI</b> REGISTERED TRADE MARK	fitvalf
<b>İLGİLİ TÜRK STANDARDI</b> RELATED TURKISH STANDARD	TS EN ISO 1452-3 / 13.12.2011
<b>BELGE KAPSAMI</b> SCOPE OF LICENCE	

PLASTİK BORU SİSTEMLERİ - İÇME VE KULLANMA SUYU İLE YER ALTI VE YER ÜSTÜ BASINÇLI DRENAJ VE  
KANALİZASYON SİSTEMLERİNDE KULLANILAN - PLASTİKLEŞTİRİCİ KATILMAMIŞ POLİVİNİL KLORÜRDEN  
(PVC-U), ELASTOMERİK HALKA CONTALI EKLEME PARÇALARI

Açık Dirsek;

Boyut grubu: 1, 2; Anma basıncı: PN 10, Boru serisi: S10, Anma dış çapı: Ø50, Ø63, Ø75, Ø90

Boyut grubu 2; Anma basıncı: PN 10, Boru serisi: S12,5, Anma dış çapı: Ø110, Ø125, Ø140, Ø160, Ø200, Ø225

Kapalı dirsek;

Boyut grubu: 1, 2; Anma basıncı: PN 10, Boru serisi: S10, Anma dış çapı: Ø50, Ø63, Ø75, Ø90

Boyut grubu 2; Anma basıncı: PN 10, Boru serisi: S12,5, Anma dış çapı: Ø110, Ø125, Ø140, Ø160, Ø200, Ø225

Te;

e-İmzalı/e-signed

27.08.2025

Belgelendirme Merkezi Başkanı Adına  
KENAN AKTÜRK

İZMİR BELGELENDİRME MÜDÜRÜ V.

\*Bu belge, belgelendirilen ürünün, üretim yerinin Enstitümüzün belirlediği şartları karşıladığını da gösterir.

\*Bu belge, hiç bir suretle tahrif edilemez, kısmen veya okunmasını zorlaştıracak şekilde çoğaltılamaz, kazıntı ve silinti yapılamaz.

\*TSE İZMİR BELGELENDİRME MÜDÜRLÜĞÜ \* Adres: 8780/1 sokak No:5 Çiğli / İZMİR \* Telefon: 0232 376 24 25(3H) \* Faks: 0 232 445 42 32

\*TSE BELGELENDİRME MERKEZ BAŞKANLIĞI: Adres: Necatibey Cad. No:112 06100 Bakanlıklar/ANKARA – Telefon: 0 312 416 64 81 / 416 64 27, Faks:0 312 416 66 17 E-posta:

bmb@tse.org.tr , web : www.tse.org.tr



<https://evrakkontrol.tse.org.tr/BelgeDogrulama.aspx?p=bdopah3g> adresinden belgenin doğruluğunu ve geçerliliğini sorgulayınız.

1 / 4



Markanın Tanımı Description of the Mark  
**TSE** veya/ort  veya/ort **Т С Е**

(071244-TSE-01/03nolu belge devamı) : STAR DERİ TEKSTİL HAVUZ VE BİLİŞİM ÜRÜNLERİ SANAYİ TİCARET İLGİLİ TÜRK STANDARDI(RELATED TURKISH STANDARD) TS EN ISO 1452-3 / 13.12.2011

Boyut grubu: 1, 2; Anma basıncı: PN 10, Boru serisi: S10, Anma dış çapı: Ø50, Ø63, Ø75, Ø90  
 Boyut grubu 2; Anma basıncı: PN 10, Boru serisi: S12,5, Anma dış çapı: Ø110, Ø125, Ø140, Ø160, Ø200, Ø225

Köle;

Boyut grubu: 2, Anma basıncı: PN 10, Boru serisi: S10, Anma dış çapı: Ø90  
 Boyut grubu 2; Anma basıncı: PN 10, Boru serisi: S12,5, Anma dış çapı: Ø110, Ø125, Ø140, Ø160, Ø200, Ø225

Flanş;

Boyut grubu: 2, Anma basıncı: PN 10, Boru serisi: S10, Anma dış çapı: Ø90  
 Boyut grubu 2; Anma basıncı: PN 10, Boru serisi: S12,5, Anma dış çapı: Ø110, Ø125, Ø140, Ø160, Ø200, Ø225

Rekor (İki tarafı içten yapıştırmalı);

Boyut grubu: 1, Anma basıncı: PN 10, Boru serisi: S10, Anma dış çapı: Ø32, Ø40, Ø50, Ø63

Rekor (Bir tarafı içten yapıştırmalı, diğer tarafı dıştan dışlı);

Boyut grubu: 1, Anma basıncı: PN 10, Boru serisi: S10, Anma dış çapı: Ø50, Ø63

İçten dişli adaptör (Anahtar ağızlı);

Boyut grubu: 1, 2; Anma basıncı: PN 10, Boru serisi: S10, Anma dış çapı: Ø50, Ø63, Ø75, Ø90  
 Boyut grubu 2; Anma basıncı: PN 10, Boru serisi: S12,5, Anma dış çapı: Ø110

Dıştan dişli adaptör (Anahtar ağızlı);

Boyut grubu: 1, 2; Anma basıncı: PN 10, Boru serisi: S10, Anma dış çapı: Ø50, Ø63, Ø75, Ø90  
 Boyut grubu 2; Anma basıncı: PN 10, Boru serisi: S12,5, Anma dış çapı: Ø110

Manşon;

Boyut grubu: 1, 2; Anma basıncı: PN 10, Boru serisi: S10, Anma dış çapı: Ø50, Ø63, Ø75, Ø90  
 Boyut grubu 2; Anma basıncı: PN 10, Boru serisi: S12,5, Anma dış çapı: Ø110, Ø125, Ø140, Ø160

Kör tapa;

Boyut grubu: 1, 2; Anma basıncı: PN 10, Boru serisi: S10, Anma dış çapı: Ø50, Ø63, Ø75, Ø90  
 Boyut grubu 2; Anma basıncı: PN 10, Boru serisi: S12,5, Anma dış çapı: Ø110, Ø125, Ø140, Ø160

Redüksiyon;

Boyut grubu: 1, 2; Anma basıncı: PN 10, Boru serisi: S10, Anma dış çapı: Ø63-50, Ø75-50, Ø75-63, Ø90-63, Ø90-75  
 Boyut grubu 2; Anma basıncı: PN 10, Boru serisi: S12,5, Anma dış çapı: Ø110-63, Ø110-75, Ø110-90, Ø125-90, Ø125-110, Ø140-90, Ø140-110, Ø140-125, Ø160-90, Ø160-110, Ø160-140, Ø200-160, Ø225-160, Ø225-200

YENİ KAPSAM:14.08.2018

PLASTİK BORU SİSTEMLERİ - İÇME VE KULLANMA SUYU İLE YER ALTI VE YER ÜSTÜ BASINÇLI DRENAJ VE KANALİZASYON SİSTEMLERİNDE KULLANILAN - PLASTİKLEŞTİRİCİ KATILMAMIŞ POLİVİNİL Klorürden (PVC-U), ELASTOMERİK HALKA CONTALI EKLEME PARÇALARI

*e-imzalı/e-signed*

27.08.2025

Belgelendirme Merkezi Başkanı Adına  
 KENAN AKTÜRK

İZMİR BELGELENDİRME MÜDÜRÜ V.

\*Bu belge, belgelendirilen ürünün, üretim yerinin Enstitümüzün belirlediği şartları karşıladığını da gösterir.

\*Bu belge, hiç bir suretle tahrif edilemez, kısmen veya okunmasını zorlaştıracak şekilde çoğaltılamaz, kopyasını ve silinti yapılamaz.

\*TSE İZMİR BELGELENDİRME MÜDÜRLÜĞÜ \* Adres: 8780/1 sokak No:5 Çiğli / İZMİR \* Telefon: 0232 376 24 25(3H) \* Faks: 0 232 445 42 32

\*TSE BELGELENDİRME MERKEZ BAŞKANLIĞI; Adres: Necatibey Cad. No:112 06100 Bakanlıkları/ANKARA – Telefon: 0 312 416 64 81 / 416 64 27, Faks:0 312 416 66 17 E-posta :bmb@tse.org.tr , web : www.tse.org.tr



<https://evrakkontrol.tse.org.tr/BelgeDogrulama.aspx?p=bdopah3g> adresinden belgenin doğruluğunu ve geçerliliğini sorgulayınız.

2 / 4



**TÜRK STANDARDLARI ENSTİTÜSÜ**  
**TÜRK STANDARDLARINA UYGUNLUK BELGESİ**  
**TURKISH STANDARDS INSTITUTION**  
**CERTIFICATE OF CONFORMITY TO TURKISH STANDARDS**

Markanın Tanımı Description of the Mark  
**TSE** veya/ve  veya/ve **T S E**

(071244-TSE-01/03nolu belge devamı) : STAR DERİ TEKSTİL HAVUZ VE BİLİŞİM ÜRÜNLERİ SANAYİ TİCARET İLGİLİ TÜRK STANDARDI(RELATED TURKISH STANDARD) TS EN ISO 1452-3 / 13.12.2011

Açık Dirsek;

Boyut grubu: 1, 2; Anma basıncı: PN 10, Boru serisi: S10, Anma dış çapı: Ø50, Ø63, Ø75, Ø90,

W/P

Boyut grubu 2; Anma basıncı: PN 10, Boru serisi: S12,5, Anma dış çapı: Ø110, Ø125, Ø140, Ø160, Ø200, Ø225,

W/P

Kapalı dirsek;

Boyut grubu: 1, 2; Anma basıncı: PN 10, Boru serisi: S10, Anma dış çapı: Ø50, Ø63, Ø75, Ø90

W/P

Boyut grubu 2; Anma basıncı: PN 10, Boru serisi: S12,5, Anma dış çapı: Ø110, Ø125, Ø140, Ø160, Ø200, Ø225 ,

W/P

Te;

Boyut grubu: 1, 2; Anma basıncı: PN 10, Boru serisi: S10, Anma dış çapı: Ø50, Ø63, Ø75, Ø90

W/P

Boyut grubu 2; Anma basıncı: PN 10, Boru serisi: S12,5, Anma dış çapı: Ø110, Ø125, Ø140, Ø160, Ø200, Ø225 ,

W/P

Köle;

Boyut grubu: 2, Anma basıncı: PN 10, Boru serisi: S10, Anma dış çapı: Ø90 ,W/P,

Boyut grubu 2; Anma basıncı: PN 10, Boru serisi: S12,5, Anma dış çapı: Ø110, Ø125, Ø140, Ø160, Ø200, Ø225 ,

W/P

Flanş;

Boyut grubu: 2, Anma basıncı: PN 10, Boru serisi: S10, Anma dış çapı: Ø90

Boyut grubu 2; Anma basıncı: PN 10, Boru serisi: S12,5, Anma dış çapı: Ø110, Ø125, Ø140, Ø160, Ø200, Ø225 ,

W/P

Rekor (İki tarafı içten yapıştırmalı);

Boyut grubu: 1, Anma basıncı: PN 10, Boru serisi: S10, Anma dış çapı: Ø32, Ø40, Ø50, Ø63, W/P

Rekor (Bir tarafı içten yapıştırmalı, diğer tarafı dıştan dişli);

Boyut grubu: 1, Anma basıncı: PN 10, Boru serisi: S10, Anma dış çapı: Ø50, Ø63, W/P

İçten dişli adaptör (Anahtar ağızlı);

Boyut grubu: 1, 2; Anma basıncı: PN 10, Boru serisi: S10, Anma dış çapı: Ø50, Ø63, Ø75, Ø90

W/P

Boyut grubu 2; Anma basıncı: PN 10, Boru serisi: S12,5, Anma dış çapı: Ø110, W/P

Dıştan dişli adaptör (Anahtar ağızlı);

e-İmzalı/e-signed

27.08.2025

Belgelendirme Merkezi Başkanı Adına  
**KENAN AKTÜRK**

İZMİR BELGELENDİRME MÜDÜRÜ V.

\*Bu belge, belgelendirilen ürünün, üretim yerinin Enstitümüzün belirlediği şartları karşıladığını da gösterir.

\*Bu belge, hiç bir suretle tahrif edilemez, kısmen veya okunmasını zorlaştıracak şekilde çoğaltılamaz, kopyasını ve silinti yapılamaz.

\*TSE İZMİR BELGELENDİRME MÜDÜRLÜĞÜ \* Adres: 8780/1 sokak No:5 Çiğli / İZMİR \* Telefon: 0232 376 24 25(3H) \* Faks: 0 232 445 42 32

\*TSE BELGELENDİRME MERKEZ BAŞKANLIĞI; Adres: Necatibey Cad. No:112 06100 Bakanlıklar/ANKARA – Telefon: 0 312 416 64 81 / 416 64 27, Faks:0 312 416 66 17 E-posta: bmb@tse.org.tr , web : www.tse.org.tr

<https://evrakkontrol.tse.org.tr/BelgeDogrulama.aspx?p=bdopah3g> adresinden belgenin doğruluğunu ve geçerliliğini sorgulayınız.



3 / 4



Markanın Tanımı Description of the Mark  
**TSE** veya/or  veya/or **T S E**

(071244-TSE-01/03nolu belge devamı) : **STAR DERİ TEKSTİL HAVUZ VE BİLİŞİM ÜRÜNLERİ SANAYİ TİCARET İLGİLİ TÜRK STANDARDI(RELATED TURKISH STANDARD) TS EN ISO 1452-3 / 13.12.2011**

Boyut grubu 1, 2; Anma basıncı: PN 10, Boru serisi: S10, Anma dış çapı: Ø50, Ø63, Ø75, Ø90, W/P

Boyut grubu 2; Anma basıncı: PN 10, Boru serisi: S12,5, Anma dış çapı: Ø110, W/P

Manşon;

Boyut grubu 1, 2; Anma basıncı: PN 10, Boru serisi: S10, Anma dış çapı: Ø50, Ø63, Ø75, Ø90 W/P

Boyut grubu 2; Anma basıncı: PN 10, Boru serisi: S12,5, Anma dış çapı: Ø110, Ø125, Ø140, Ø160, W/P

Kör tapa;

Boyut grubu 1, 2; Anma basıncı: PN 10, Boru serisi: S10, Anma dış çapı: Ø50, Ø63, Ø75, Ø90

W/P

Boyut grubu 2; Anma basıncı: PN 10, Boru serisi: S12,5, Anma dış çapı: Ø110, Ø125, Ø140, Ø160, W/P

Redüksiyon;

Boyut grubu 1, 2; Anma basıncı: PN 10, Boru serisi: S10, Anma dış çapı: Ø63-50, Ø75-50, Ø75-63, Ø90-63, Ø90-75, W/P

Boyut grubu 2; Anma basıncı: PN 10, Boru serisi: S12,5, Anma dış çapı: Ø110-63, Ø 110-75, Ø110-90, Ø 125-90, Ø 125-110, Ø140-90, Ø140-110, Ø 140-125, Ø160-90, Ø160-110, Ø160-140, Ø200-160, Ø225-160, Ø225-200, W/P

*e-İmzalı/e-signed*

27.08.2025

Belgelendirme Merkezi Başkanı Adına  
**KENAN AKTÜRK**

**İZMİR BELGELENDİRME MÜDÜRÜ V.**

\*Bu belge, belgelendirilen ürünün, üretim yerinin Enstitümüzün belirlediği şartları karşıladığını da gösterir.

\*Bu belge, hiç bir suretle lahrif edilemez, kısmen veya okunmasını zorlaştıracak şekilde çoğaltılamaz, kızıntı ve silinti yapılamaz.

\*TSE İZMİR BELGELENDİRME MÜDÜRLÜĞÜ \* Adres: 8780/1 sokak No:5 Çiğli / İZMİR \* Telefon: 0232 376 24 25(3H) \* Faks: 0 232 445 42 32

\*TSE BELGELENDİRME MERKEZ BAŞKANLIĞI; Adres: Necatibey Cad. No:112 06100 Bakanlıklar/ANKARA – Telefon: 0 312 416 64 81 / 416 64 27, Faks:0 312 416 66 17 E-posta: bmb@tse.org.tr , web : www.tse.org.tr

<https://evrakkontrol.tse.org.tr/BelgeDogrulama.aspx?p=bdopah3g> adresinden belgenin doğruluğunu ve geçerliliğini sorgulayınız.



4 / 4

# Sertifika Certificate



## STAR DERİ TEKSTİL HAVUZ VE BİLİŞİM ÜRÜNLERİ SANAYİ TİCARET VE ANONİM ŞİRKETİ

10001 SK NO:28 İDARİ BİNA ZEMİN KAT İTOB TEKELİ KÖYÜ MENDERES / İZMİR  
SUBE ADRESİ: İTOB ORGANİZE SANAYİ BÖLGESİ 10030 SK. NO 10 TEKELİ MENDERES / İZMİR

DSR BELGELENDİRME tarafından denetlenmiş ve uygulamakta olduğu  
Çevre Yönetim Sisteminin

*is audited by DSR Certification and applied  
Environmental Management System meet the requirements of*

# ISO 14001:2015

standardına aşağıdaki kapsamda uymakta olduğu gözlenmiştir.  
*standard for the following activities.*

**PVC, PLASTİK HAVUZ EKİPMANLARI VE BAĞLANTI ELEMANLARI İMALATI VE SATIŞI**

*MANUFACTURE AND SALES OF PVC, PLASTIC POOL EQUIPMENTS AND FASTENERS*

**Sertifika No / Certificate No: EMS-24.11.341**

14.11.2024  
Sertifika Tarihi  
Certificate Date

14.11.2024  
Sertifika Son Basım Tarihi  
Certificate Last Issue Date

13.11.2026  
Sertifika Geçerlilik Tarihi  
Certificate Expiry Date

3 Yıl/Years  
Belgelendirme Periyodu  
Certification Period

EA Kodu/EA Code: 14



DSR CERTIFICATION AND INSPECTION, LLC

950 RIDGE ROAD SUITE D11 1596 CLAYMONT, DELAWARE 19703 UNITED STATES  
E-mail: info@dsrbelgelendirme.com.tr - Web: www.dsrbelgelendirme.com.tr

# Sertifika Certificate



## STAR DERİ TEKSTİL HAVUZ VE BİLİŞİM ÜRÜNLERİ SANAYİ TİCARET VE ANONİM ŞİRKETİ

10001 SK NO:28 İDARİ BİNA ZEMİN KAT İTOB TEKELİ KÖYÜ MENDERES / İZMİR  
SUBE ADRESİ: İTOB ORGANİZE SANAYİ BÖLGESİ 10030 SK. NO 10 TEKELİ MENDERES / İZMİR

DSR BELGELENDİRME tarafından denetlenmiş ve uygulamakta olduğu  
Kalite Yönetim Sisteminin

*is audited by DSR Certification and applied  
Quality Management System meet the requirements of*

# ISO 9001:2015

standardına aşağıdaki kapsamda uymakta olduğu gözlenmiştir.  
*standard for the following activities.*

PVC, PLASTİK HAVUZ EKİPMANLARI VE BAĞLANTI ELEMANLARI İMALATI VE SATIŞI

MANUFACTURE AND SALES OF PVC, PLASTIC POOL EQUIPMENTS AND FASTENERS

**Sertifika No / Certificate No: QMS- 24.11.341**

14.11.2024  
Sertifika Tarihi  
Certificate Date

14.11.2024  
Sertifika Son Basım Tarihi  
Certificate Last Issue Date

13.11.2026  
Sertifika Geçerlilik Tarihi  
Certificate Expiry Date

3 Yıl/Years  
Belgelendirme Periyodu  
Certification Period

EA Kodu/EA Code: 14

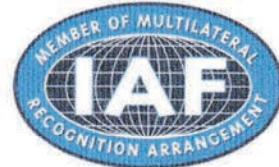

DSR CERTIFICATION AND INSPECTION, LLC

950 RIDGE ROAD SUITE D11 1596 CLAYMONT, DELAWARE 19703 UNITED STATES  
E-mail: info@dsrbelgelendirme.com.tr - Web: www.dsrbelgelendirme.com.tr

# Sertifika Certificate



## STAR DERİ TEKSTİL HAVUZ VE BİLİŞİM ÜRÜNLERİ SANAYİ TİCARET VE ANONİM ŞİRKETİ

10001 SK NO:28 İDARİ BİNA ZEMİN KAT İTOB TEKELİ KÖYÜ MENDERES / İZMİR  
ŞUBE ADRESİ: İTOB ORGANİZE SANAYİ BÖLGESİ 10030 SK. NO 10 TEKELİ MENDERES / İZMİR

DSR BELGELENDİRME tarafından denetlenmiş ve uygulamakta olduğu  
İş Sağlığı ve Güvenliği Yönetim Sisteminin  
*is audited by DSR Certification and applied*  
*Occupational Health and Safety Management System meet the requirements of*

# ISO 45001:2018

standardına aşağıdaki kapsamda uymakta olduğu gözlenmiştir.  
*standard for the following activities.*

PVC, PLASTİK HAVUZ EKİPMANLARI VE BAĞLANTI ELEMANLARI İMALATI VE SATIŞI

MANUFACTURE AND SALES OF PVC, PLASTIC POOL EQUIPMENTS AND FASTENERS

**Sertifika No / Certificate No: ISG-24.11.341**

14.11.2024  
Sertifika Tarihi  
Certificate Date

14.11.2024  
Sertifika Son Basım Tarihi  
Certificate Last Issue Date

13.11.2026  
Sertifika Geçerlilik Tarihi  
Certificate Expiry Date

3 Yıl/Years  
Belgelendirme Periyodu  
Certification Period



DSR CERTIFICATION AND INSPECTION, LLC

950 RIDGE ROAD SUITE D11 1596 CLAYMONT, DELAWARE 19703 UNITED STATES  
E-mail: info@dsrbelgelendirme.com.tr - Web: www.dsrbelgelendirme.com.tr



**TÜRK  
PATENT**  
TÜRK PATENT VE MARKA KURUMU

# MARKA YENİLEME BELGESİ

No: 2013 10614 - Ticaret - Hizmet



Marka Sahibi

**STAR DERİ TEKSTİL HAVUZ VE BİLİŞİM ÜRÜNLERİ SANAYİ TİCARET ANONİM ŞİRKETİ**

Mal / Hizmet Sınıfları

**17, 19, 35**

Bu marka, 05.02.2013 tarihli başvuru üzerine 27.12.2013 tarihinde tescil edilmiş olup, 6769 sayılı Sınai Mülkiyet Kanunu kapsamında 05.02.2023 tarihinden itibaren 10 yıl süreyle yenilenmiştir.

**Cemil BAŞPINAR**  
Kurum Başkanı

 Bundesrepublik Deutschland 

# Urkunde

über die Eintragung des  
Gebrauchsmusters Nr. 20 2015 105 920

**Bezeichnung:**

Der als Montagewerkzeug dienender Kurbel für PVC Kugelhähne

**IPC:**

F16K 5/10

**Inhaber/Inhaberin:**

STAR DERI TEKSTIL HAVUS VE BIL.ÜRÜN.SAN.TIC.A.Ş., Izmir, TR

**Tag der Anmeldung:**

05.11.2015

**Tag der Eintragung:**

07.01.2016

Die Präsidentin des Deutschen Patent- und Markenamts

*Cornelia Rudloff-Schäffer*

Cornelia Rudloff-Schäffer

München, 07.01.2016



Die Voraussetzungen der Schutzfähigkeit werden bei der Eintragung eines Gebrauchsmusters nicht geprüft. Den aktuellen Rechtsstand und Schutzzumfang entnehmen Sie bitte dem DPMAregister unter [www.dpma.de](http://www.dpma.de).



## CERTIFICATE OF REGISTRATION

The International Bureau of the World Intellectual Property Organization (WIPO) certifies that the indications appearing in the present certificate conform to the recording made in the International Register of Marks maintained under the Madrid Agreement and Protocol.

Reproduction of the mark in color under Rule 9.4(a)(vii)



Registration number	<b>1 233 454</b>
Registration date	<b>March 21, 2014</b>
Date next payment due	<b>March 21, 2024</b>
Name and address of holder	STAR DERİ TEKSTİL HAVUZ VE BİLİŞİM ÜRÜNLERİ SANAYİ VE TİCARET ANONİM ŞİRKETİ İtob Organize Sanayi Bölgesi 10001, Sokak No:28 Tekeli Menderes, İzmir (Turkey)
Legal nature of the holder (legal entity) and place of organization	Joint-Stock Company, Turkey
Name and address of the representative	Hedef Kurumsal Hizmet Kalite Belgelendirme Marka Patent Danışmanlık Hizmetleri Limited Şirketi, Barış Mh., İkbal Sk., Atalay 10 Sitesi No:13 Kat:6 D:12, Nilüfer/BURSA (Turkey)
Classification of figurative elements	1.15; 25.1; 29.1
List of goods and services NCL(10-2014)	17 Rubber, gutta-percha, gum, asbestos, mica and semi-finished synthetic goods made from these materials in the form of powder, bars, panels and foils included in this class; insulation, stopping and sealing materials; joint sealant compounds for joints, gaskets, O-rings for sealing purposes; flexible pipes made from rubber and plastic; hoses made of plastic and rubber, including those used for vehicles; junctions for pipes of plastic and rubber; pipe jackets of plastic and rubber; hoses of textile material; junctions for pipes, not of metal; pipe jackets, not of metal; connecting hose for vehicle radiators. 19 Sand, gravel, crushed stone, asphalt, bitumen, cement, gypsum for use in construction, road construction, repair and

**CERTIFICATE OF REGISTRATION**

(continued) 1 233 454

covering work; building materials (as finished products) made of concrete, gypsum, clay, potters' clay, natural or artificial stone, wood, plastics and synthetic materials for building, construction, road construction purposes, included in this class; non-metallic building materials, non-metallic transportable buildings, poles not of metal, barriers not of metal, doors and windows of wood and synthetic materials; traffic signs not of metal, non-luminous and non-mechanical, for roads; monuments and statuettes of stone, concrete and marble; natural and synthetic surface coatings in the form of panels and sheets, being building materials; heat adhesive synthetic surface coating, being building materials; bitumen cardboard coatings for roofing; bitumen coating for roofing; building glass; prefabricated swimming pools not of metal (structures); aquarium sand.

- 35 The bringing together, for the benefit of others, of a variety of goods, enabling customers to conveniently view and purchase those goods, namely, rubber, gutta-percha, gum, asbestos, mica and goods made from these materials, plastics in extruded form for use in manufacture, packing, stopping and insulating materials, flexible pipes, not of metal, building materials (non-metallic), non-metallic rigid pipes for building, asphalt, pitch and bitumen, non-metallic transportable buildings, monuments, not of metal, such services may be provided by retail stores, wholesale outlets, by means of electronic media or through mail order catalogues.

*Basic registration* Turkey, 05.02.2013, 2013 10614

*Designations under the Madrid Protocol* France, Morocco, Poland, Russian Federation

*Date of notification* 05.02.2015

*Language of the international application* English



Ásta Valdimarsdóttir  
 Director, Operations Service  
 Madrid Registry  
 Brands and Designs Sector

Geneva, February 5, 2015



## INTERNATIONAL REGISTRATION CERTIFICATE

The International Bureau of the World Intellectual Property Organization (WIPO) hereby certifies that the particulars given below correspond to the recording made in the International Register of Industrial Designs, at the date of the international registration, under the Hague Agreement Concerning the International Registration of Industrial Designs.

<i>Registration number</i>	<b>DM/088 552</b>
<i>Date of the international registration</i>	<b>11.11.2015</b>
<i>Filing date</i>	11.11.2015
<i>Name and address of holder</i>	STAR DERİ TEKSTİL HAVUZ VE BİLİŞİM ÜRÜNLERİ SANAYİ TİCARET ANONİM ŞİRKETİ 10001 Sokak No:28, İdari Bina Zeminkat İtob Tekeli Köyü, MENDERES/İZMİR (Turkey)
<i>Contracting Party of which the holder is a national</i>	Turkey
<i>Contracting Party of which the holder has a domicile</i>	Turkey
<i>Contracting Party of which the holder has an industrial or commercial establishment</i>	Turkey
<i>Contracting Party in which the holder has a habitual residence</i>	Turkey
<i>Applicant's Contracting Party</i>	Turkey
<i>Name and address of the representative</i>	Hedef Kurumsal Hizmet Kalite Belgelendirme Marka Patent Danışmanlık Hizmetleri Limited Şirketi Barış Mh., İkbal Sk. Atalay 11, Sitesi No:15 Kat:3 D:7, Nilüfer, Bursa (Turkey)
<i>Number of designs included in the international registration</i>	1
<i>Locarno Classification</i>	Cl. 23-01
<i>Indication of products</i>	1. PVC spherical valve.
<i>Contracting Parties designated under the 1999 Act</i>	European Union

**INTERNATIONAL REGISTRATION CERTIFICATE** (continued) **DM/088 552**

1.1



1.2



**INTERNATIONAL REGISTRATION CERTIFICATE** (continued) **DM/088 552**

1.3



A handwritten signature in black ink, appearing to read 'Patrick Cartant'.

Patrick CARTANT  
Head, Operations Service  
The Hague Registry  
Brands and Designs Sector

Geneva, December 14, 2015



UPVC FITTINGS & VALVES

