

VERTICAL MULTISTAGE ELECTRIC PUMPS

in cast iron, AISI 304, AISI 316



Vertical multistage centrifugal electric pumps available in various versions: cast iron (EVMG), AISI 304 stainless steel (EVM), AISI 316 stainless steel (EVML).

APPLICATIONS

- Suitable for civil, industrial, agricultural and fire-fighting pressure boosting systems
- Primary water treatment plants
- Reverse osmosis, seepage, etc.
- Moving moderately aggressive fluids
- Boiler loading
- Washing
- Heating systems and air-conditioning

TECHNICAL DETAILS

- Reliable, strong, silent and easy to service
- The EVM pumps can be coupled with standard IEC motors
- They offer state-of-the-art technical solutions
- The EVM vertical multistage pumps (hydraulic parts) are in compliance with the 94/9/CE Directive on ATEX products (they belong to Group II, Category 2), zones 1 and 2, temperature class T2 and T4
- Oval counter-flanges, "N" version, already included
- Round counter-flanges, "F" version, as accessories
- WRAS approval for standard version of EVM 3-5-10-18

PERFORMANCE RANGE a 2900 min⁻¹ (according to ISO 9906 Attachment A)

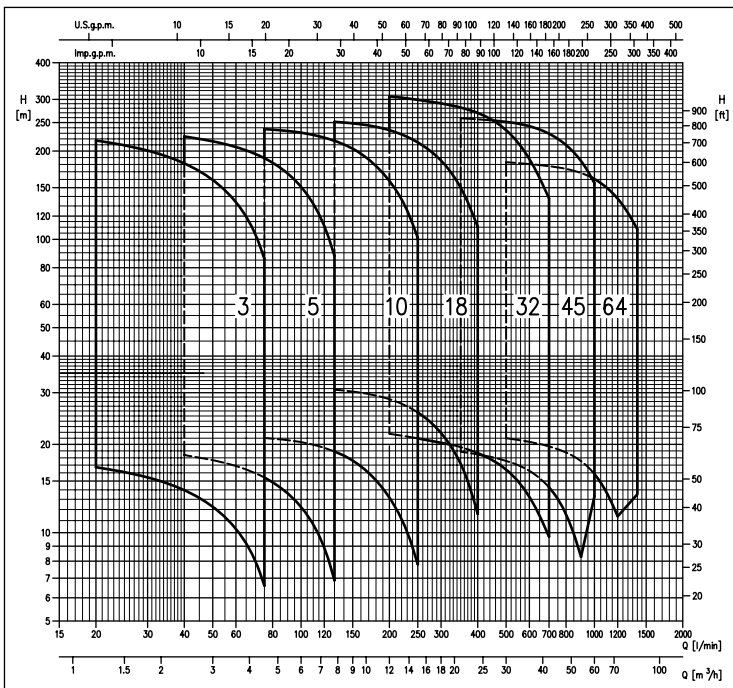

PUMP TECHNICAL DATA

- Maximum working pressure: 16 bar, 25 bar, 30 bar for EVM32 - EVM45 only
 - Temperature of the liquid: from -15°C to +120°C
 - Maximum solid content: 50 ppm (particle size 0,1-0,25 mm or less)
 - Maximum chlorine ion density: 500 ppm
 - MEI > 0,4
- For further information please see our Data Book on the web site www.ebaraeurope.com

MOTOR TECHNICAL DATA

- IE3 high energy-efficiency motors starting from 2.2 kW to 37 kW
- High efficiency IE2 motors starting from 2.2 kW to 5.5 kW
- Self-ventilated 2 poles asynchronous motor
- Class of insulation F
- IP55 Protection degree
- Single phase voltage 230V ±10% 50Hz, three phase voltage 230/400V ±10%, 50Hz (up to 4 kW included), three phase voltage 400/690V ±10% (5.5 kW and above)
- Circuit breaker protection under user's responsibility

MATERIALS

- Lower pump body, external casing, seal housing disc, impellers, diffusers, shaft casing, joint cover and small elements in contact with the liquid in AISI 304 (EVM), AISI 316 (EVML) ["EVMG" version: pump casing in cast iron and hydraulic part in AISI 304]
- Tie-rods and small elements not in contact with the liquid in galvanised steel
- Shaft in AISI 316
- Bearings in contact with the liquid in tungsten carbide
- Motor bracket in cast iron (EVMG), in cast iron/AISI 304 (EVM), in cast iron/AISI 316
- Mechanical seal in SiC/Carbon/EPDM (EVM-EVMG 3-5-10-18)
- Mechanical seal in SiC/Carbon/FPM (EVML 3-5-10-18)
- Mechanical seal with cartridge as per standard in SiC/Carbon/FPM (models 32-45-64) (F= round counterflanges; N= oval counterflanges)
- Liner rings in PTFE

SPECIAL VERSION

- Motor in insulation class B available for high temperature
- ATEX version for the electropump

ACCESSORIES (On request)

- Round counter-flanges for "F" version available in:
 - galvanised/EPDM
 - AISI 304/EPDM
 - AISI 316/FPM



VERTICAL MULTISTAGE ELECTRIC PUMPS

in cast iron, AISI 304, AISI 316

IDENTIFICATION CODE EVM 3-18

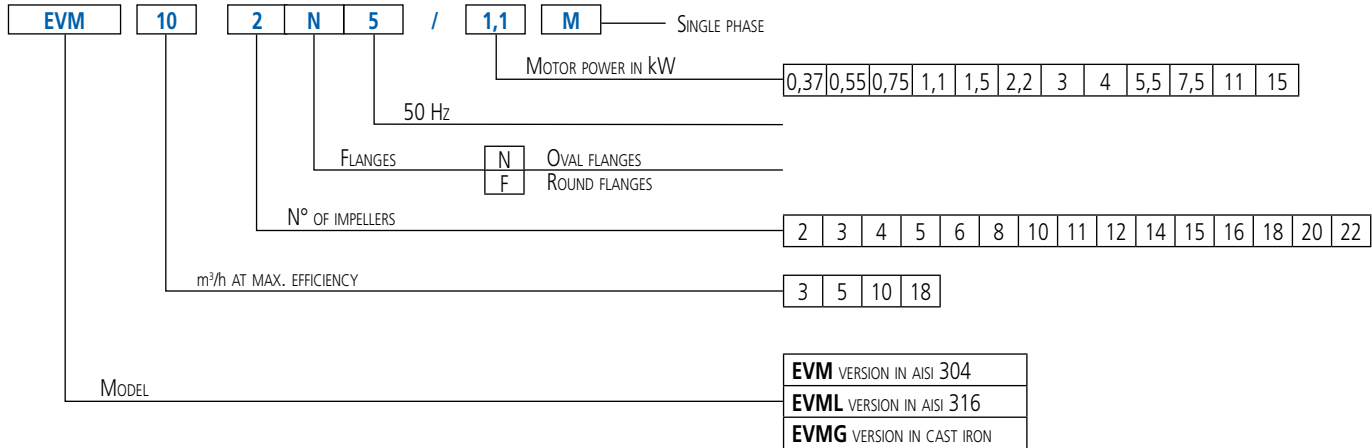

IDENTIFICATION CODE EVM 32-64

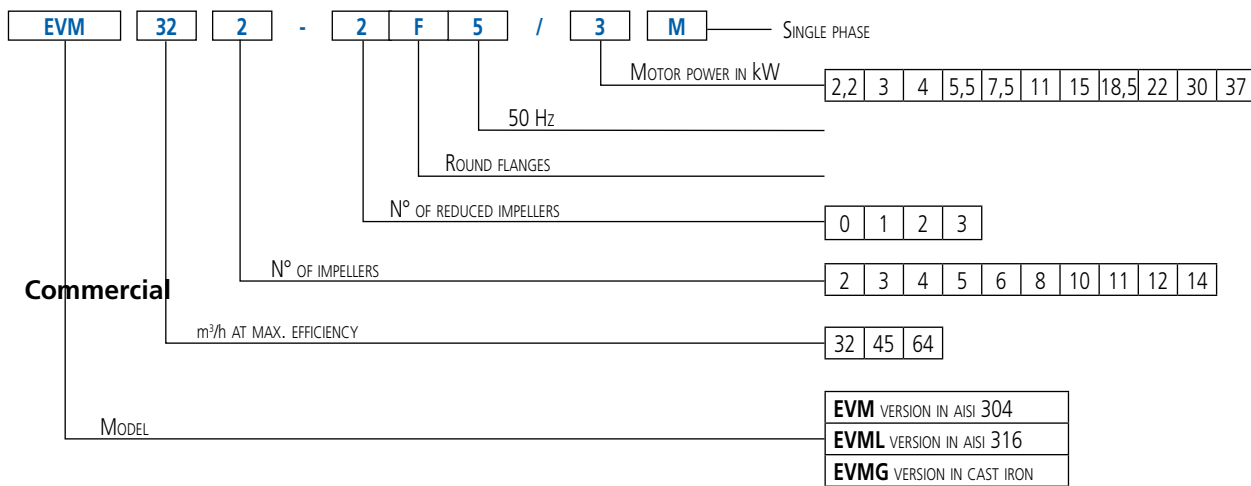

MECHANICAL SEAL WITH CARTRIDGE

The EVM 32-45-64 pumps house the mechanical seal with cartridge as per standard.

All of the components of the mechanical seal constitute just one part on one shaft sleeve. The mechanical seal is ready to be installed between the pump shaft and the motor shaft.

The benefits of this type of seal are:

- Easy to install
- Safety and easy to use

We are at your disposal to evaluate all demands and requirements in order to find the best solution for your plants and applications.

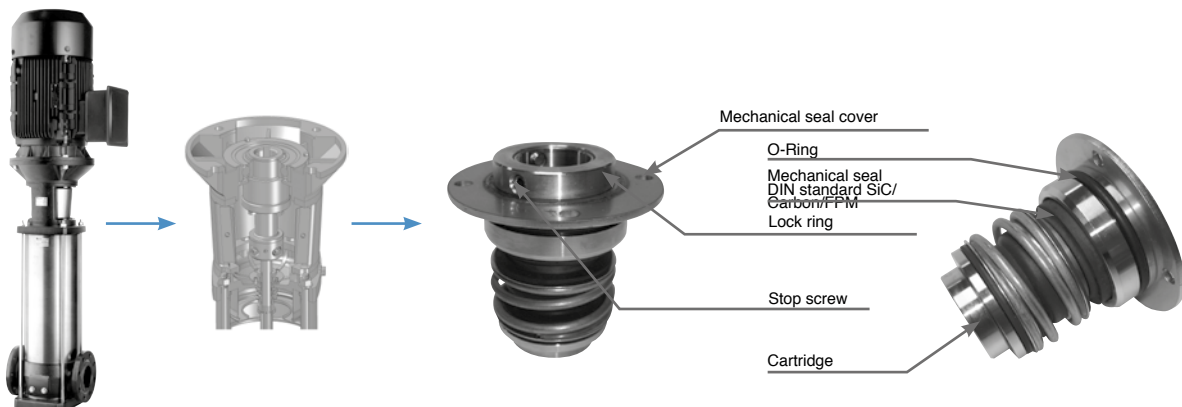

I contenuti della presente pubblicazione non devono essere considerati impegnativi. EBARA Pumps Europa S.p.A. si riserva il diritto di apportare senza preavviso le modifiche che ritenga più opportune.



EVM

VERTICAL MULTISTAGE ELECTRIC PUMPS

in cast iron, AISI 304, AISI 316

PERFORMANCE RANGE a 2900 min⁻¹ (according to ISO 9906 Attachment A)

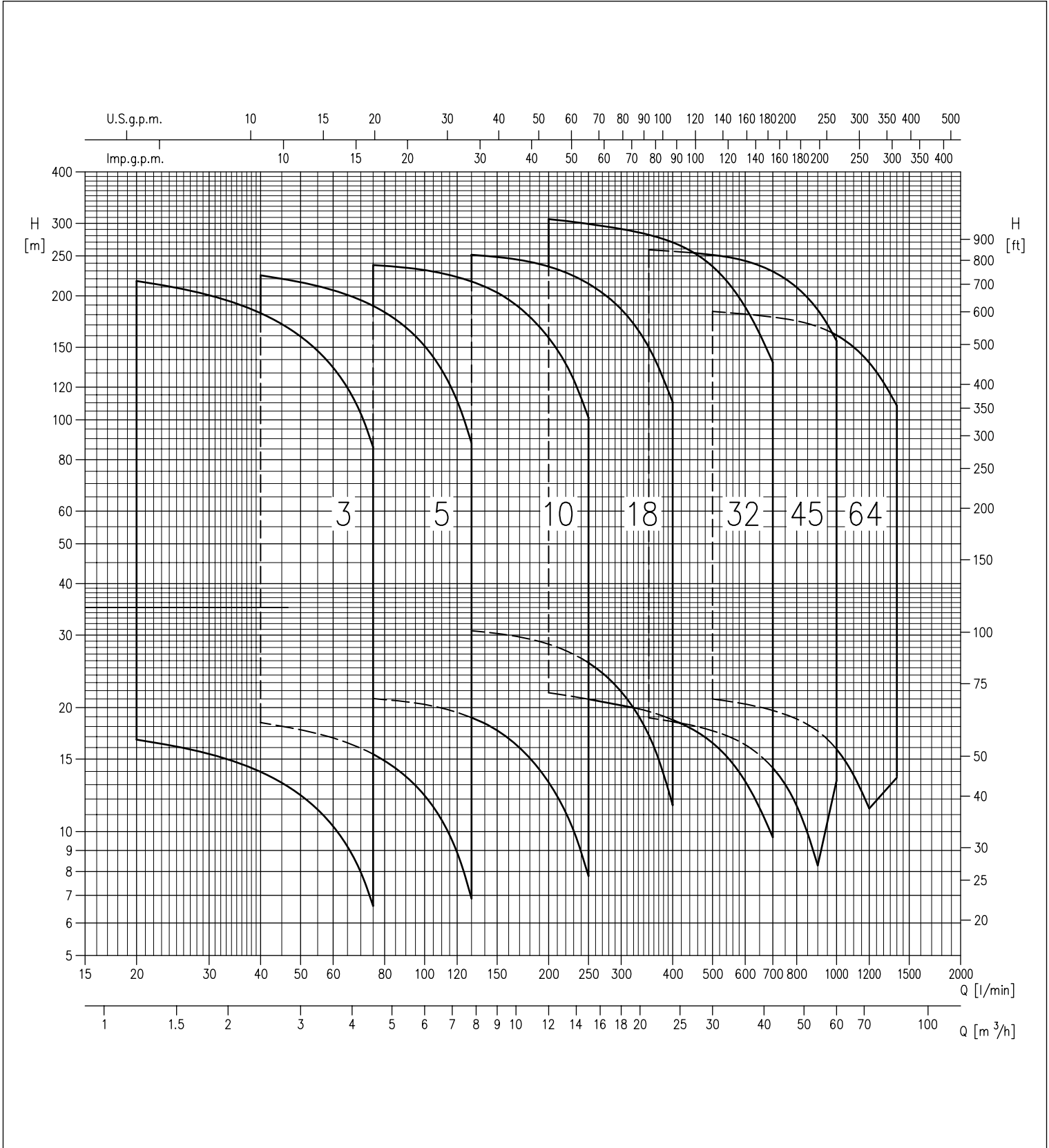

I contenuti della presente pubblicazione non devono essere considerati ingratificati. EBARA Pumps Europe Sp. A. si riserva il diritto di apportare senza preavviso le modifiche che riterrà più opportune.

VERTICAL MULTISTAGE ELECTRIC PUMPS

in cast iron, AISI 304, AISI 316

PERFORMANCE TABLE EVM 3-5-10-18

Model	P ₁		Motor Mec	Max. working pressure [MPa]	Q=Flow rate															Pump	Weight [kg]		
	[HP]	[kW]			H=Head [m]																Pump + Motor		
				l/min m ³ /h	20 1,2	40 2,4	60 3,6	75 4,5	100 6	130 7,8	150 9	200 12	250 15	300 18	350 21	400 24		[2]	[1]	[3]			
EVM 3 2N5/0.37 (M)	0,5	0,37	71	1,6	16,7	14,0	10,3	6,6	-	-	-	-	-	-	-	-	11,3	17,0	17,1	-			
EVM 3 3N5/0.37 (M)	0,5	0,37	71	1,6	25,1	20,9	15,5	9,9	-	-	-	-	-	-	-	-	11,8	17,5	17,6	-			
EVM 3 4N5/0.55 (M)	0,75	0,55	71	1,6	33,4	27,9	20,6	13,2	-	-	-	-	-	-	-	-	12,3	19,3	18,5	-			
EVM 3 5N5/0.55 (M)	0,75	0,55	71	1,6	42,0	34,9	25,8	16,5	-	-	-	-	-	-	-	-	12,8	19,8	19,0	-			
EVM 3 6N5/0.75 (M)	1	0,75	80	1,6	50,0	42,0	30,9	19,8	-	-	-	-	-	-	-	-	13,7	25,1	22,1	-			
EVM 3 7N5/0.75 (M)	1	0,75	80	1,6	58,5	49,0	36,1	23,1	-	-	-	-	-	-	-	-	13,9	25,3	22,3	-			
EVM 3 9N5/1.1 (M)	1,5	1,1	80	1,6	75,0	63,0	46,5	29,7	-	-	-	-	-	-	-	-	14,8	26,6	25,9	-			
EVM 3 11N5/1.1 (M)	1,5	1,1	80	1,6	92,0	77,0	56,5	36,3	-	-	-	-	-	-	-	-	16,2	28,0	27,3	-			
EVM 3 13N5/1.5 (M)	2	1,5	90S	1,6	109,0	90,5	67,0	43,0	-	-	-	-	-	-	-	-	17,7	35,5	31,7	-			
EVM 3 15N5/1.5 (M)	2	1,5	90S	1,6	125,0	105,0	77,5	49,5	-	-	-	-	-	-	-	-	19,2	37,0	33,2	-			
EVM 3 18F5/2.2 (M)	3	2,2	90L	2,5	151,0	126,0	92,5	59,5	-	-	-	-	-	-	-	-	24,8	44,3	40,8	-			
EVM 3 22F5/2.2 (M)	3	2,2	90L	2,5	184,0	154,0	113,0	72,5	-	-	-	-	-	-	-	-	27,2	46,7	43,2	-			
EVM 3 26F5/3.0	4	3	100	2,5	217,0	182,0	134,0	86,0	-	-	-	-	-	-	-	-	30,8	-	53,6	-			
EVM 5 2N5/0.37 (M)	0,5	0,37	71	1,6	-	18,4	16,9	15,4	12,2	6,9	-	-	-	-	-	-	11,5	17,2	17,3	-			
EVM 5 3N5/0.55 (M)	0,75	0,55	71	1,6	-	27,6	25,3	23,1	18,4	10,3	-	-	-	-	-	-	12,0	19,0	18,2	-			
EVM 5 4N5/0.75 (M)	1	0,75	80	1,6	-	36,8	33,8	30,8	24,5	13,8	-	-	-	-	-	-	12,9	24,3	21,3	-			
EVM 5 5N5/1.1 (M)	1,5	1,1	80	1,6	-	46,0	42,0	38,6	30,6	17,2	-	-	-	-	-	-	13,5	25,3	24,6	-			
EVM 5 6N5/1.1 (M)	1,5	1,1	80	1,6	-	55,0	50,5	46,5	36,7	20,6	-	-	-	-	-	-	14,1	25,9	25,2	-			
EVM 5 7N5/1.5 (M)	2	1,5	90S	1,6	-	64,5	59,0	54,0	43,0	24,1	-	-	-	-	-	-	14,9	32,7	28,9	-			
EVM 5 8N5/1.5 (M)	2	1,5	90S	1,6	-	73,5	67,5	61,5	49,0	27,5	-	-	-	-	-	-	15,5	33,3	29,5	-			
EVM 5 10N5/2.2 (M)	3	2,2	90L	1,6	-	93,5	86,0	79,0	63,0	36,6	-	-	-	-	-	-	17,9	37,4	33,9	-			
EVM 5 11N5/2.2 (M)	3	2,2	90L	1,6	-	103,0	94,5	86,5	69,5	40,5	-	-	-	-	-	-	19,0	38,5	35,0	-			
EVM 5 12N5/2.2 (M)	3	2,2	90L	1,6	-	112,0	103,0	94,5	75,5	44,0	-	-	-	-	-	-	19,7	39,2	35,7	-			
EVM 5 14N5/3.0	4	3	100	1,6	-	131,0	120,0	110,0	88,0	51,0	-	-	-	-	-	-	22,0	-	44,8	-			
EVM 5 16N5/3.0	4	3	100	1,6	-	150,0	138,0	126,0	101,0	58,5	-	-	-	-	-	-	23,3	-	46,1	-			
EVM 5 18F5/4.0	5,5	4	112	2,5	-	168,0	155,0	142,0	113,0	66,0	-	-	-	-	-	-	28,7	-	51,5	-			
EVM 5 19F5/4.0	5,5	4	112	2,5	-	178,0	163,0	150,0	120,0	69,5	-	-	-	-	-	-	29,4	-	52,2	-			
Commercial EVM 5 20F5/4.0	5,5	4	112	2,5	-	206,0	189,0	173,0	139,0	80,5	-	-	-	-	-	-	31,2	-	54,0	-			
EVM 5 24F5/5.5	7,5	5,5	132S	2,5	-	224,0	206,0	189,0	151,0	88,0	-	-	-	-	-	-	35,4	-	74,0	-			
EVM 10 2N5/0.75 (M)	1	0,75	80	1,6	-	-	-	21,0	20,4	18,9	17,6	13,2	7,8	-	-	-	18,0	29,4	26,4	-			
EVM 10 3N5/1.1 (M)	1,5	1,1	80	1,6	-	-	-	31,6	30,5	28,4	26,4	19,8	11,7	-	-	-	19,5	31,3	30,6	-			
EVM 10 4N5/1.5 (M)	2	1,5	90S	1,6	-	-	-	42,0	40,5	37,8	35,2	26,4	15,6	-	-	-	21,9	39,7	35,9	-			
EVM 10 5N5/2.2 (M)	3	2,2	90L	1,6	-	-	-	52,5	51,0	47,5	44,0	33,0	19,5	-	-	-	22,5	42,0	38,5	-			
EVM 10 6N5/2.2 (M)	3	2,2	90L	1,6	-	-	-	63,0	61,0	57,0	53,0	39,5	23,4	-	-	-	24,0	43,5	40,0	-			
EVM 10 8N5/3.0	4	3	100	1,6	-	-	-	84,0	81,5	75,5	70,5	52,5	31,2	-	-	-	30,6	-	53,4	-			
EVM 10 10N5/4.0	5,5	4	112	1,6	-	-	-	105,0	102,0	94,5	88,0	66,0	39,0	-	-	-	31,5	-	54,3	-			
EVM 10 11N5/4.0	5,5	4	112	1,6	-	-	-	116,0	112,0	104,0	97,0	72,5	43,0	-	-	-	34,0	-	56,8	-			
EVM 10 12N5/5.5	7,5	5,5	132S	1,6	-	-	-	130,0	126,0	118,0	111,0	86,5	55,0	-	-	-	39,3	-	77,9	-			
EVM 10 14N5/5.5	7,5	5,5	132S	1,6	-	-	-	151,0	147,0	138,0	130,0	101,0	64,5	-	-	-	41,8	-	80,4	-			
EVM 10 15F5/5.5	7,5	5,5	132S	2,5	-	-	-	162,0	158,0	148,0	139,0	108,0	69,0	-	-	-	45,8	-	84,4	-			
EVM 10 16F5/7.5	10	7,5	132S	2,5	-	-	-	173,0	168,0	158,0	148,0	115,0	73,5	-	-	-	47,8	-	88,2	90,2			
EVM 10 18F5/7.5	10	7,5	132S	2,5	-	-	-	194,0	189,0	177,0	167,0	129,0	83,0	-	-	-	49,8	-	90,2	92,2			
EVM 10 20F5/7.5	10	7,5	132S	2,5	-	-	-	216,0	210,0	197,0	185,0	144,0	92,0	-	-	-	49,8	-	90,2	92,2			
EVM 10 22F5/11	15	11	160M	2,5	-	-	-	238,0	231,0	217,0	204,0	158,0	101,0	-	-	-	55,5	-	118,0	128,8			
EVM 18 2F5/2.2 (M)	3	2,2	90L	1,6	-	-	-	-	-	31,0	30,3	28,5	25,7	21,9	17,2	11,6	27,4	46,9	43,4	-			
EVM 18 3F5/3.0	4	3	100	1,6	-	-	-	-	-	46,0	45,5	43,0	38,6	32,8	25,7	17,4	28,9	-	51,7	-			
EVM 18 4F5/4.0	5,5	4	112	1,6	-	-	-	-	-	61,5	60,5	57,0	51,5	44,0	34,3	23,2	31,4	-	54,2	-			
EVM 18 5F5/5.5	7,5	5,5	132S	1,6	-	-	-	-	-	77,0	75,5	71,5	64,5	54,5	43,0	29,0	38,4	-	77,0	-			
EVM 18 6F5/5.5	7,5	5,5	132S	1,6	-	-	-	-	-	92,0	91,0	85,5	77,0	65,5	51,5	34,8	41,4	-	80,0	-			
EVM 18 7F5/7.5	10	7,5	132S	2,5	-	-	-	-	-	108,0	106,0	100,0	90,0	76,5	60,0	40,5	43,9	-	84,3	86,3			
EVM 18 8F5/7.5	10	7,5	132S	2,5	-	-	-	-	-	123,0	121,0	114,0	103,0	87,5	68,5	46,5	43,8	-	84,2	86,2			
EVM 18 10F5/11	15	11	160M	2,5	-	-	-	-	-	157,0	155,0	147,0	134,0	116,0	93,5	69,0	54,3	-	116,8	127,6			
EVM 18 12F5/11	15	11	160M	2,5	-	-	-	-	-	189,0	186,0	177,0	160,0	139,0	112,0	83,0	57,3	-	119,8	130,6			
EVM 18 14F5/15	20	15	160M	2,5	-	-	-	-	-	220,0	217,0	206,0	187,0	162,0	131,0	96,5	57,8	-	144,9	161,8			
EVM 18 15F5/15	20	15	160M	2,5	-	-	-	-	-	236,0	233,0	221,0	201,0	174,0	141,0	104,0	58,3	-	145,4	162,3			
EVM 18 16F5/15	20	15	160M	2,5	-	-	-	-	-	252,0	249,0	236,0	214,0	186,0	150,0	110,0	61,3	-	148,4	165,3			

1,6 MPa= 16 bar
2,5 MPa= 25 bar

[1]= Only three-phase
[2]= Only single-phase
[3]= Only for IE3 motors

VERTICAL MULTISTAGE ELECTRIC PUMPS

in cast iron, AISI 304, AISI 316

PERFORMANCE TABLE EVM 32-45

Model	P ₂		Motor Mec	Max. working pressure [MPa]	Q=Flow rate						Weight [kg]				
	[HP]	[kW]			l/min	200	350	500	600	700	900	1000	Pump	Pump + Motor	
					m ³ /h	12	21	30	36	42	54	60		[1]	
						H=Head [m]									
EVM 32 1-0F5/2.2	3	2,2	90L	1,6		21,7	19,6	16,4	13,2	9,7	-	-	56,0	72,0	-
EVM 32 2-2F5/3.0	4	3	100	1,6		36,9	31,6	23,5	17,4	-	-	-	58,0	80,8	-
EVM 32 2-0F5/4.0	5,5	4	112	1,6		43,5	39,2	32,8	26,5	19,4	-	-	58,0	80,8	-
EVM 32 3-3F5/5.5	7,5	5,5	132S	1,6		55,5	47,5	35,2	26,1	-	-	-	74,0	112,6	-
EVM 32 3-1F5/5.5	7,5	5,5	132S	1,6		62,0	55,0	44,5	35,2	24,5	-	-	74,0	112,6	-
EVM 32 4-3F5/7.5	10	7,5	132S	1,6		77,0	67,0	51,5	39,4	-	-	-	77,0	117,4	119,4
EVM 32 4-1F5/7.5	10	7,5	132S	1,6		83,5	74,5	61,0	48,5	34,2	-	-	77,0	117,4	119,4
EVM 32 5-3F5/11	15	11	160M	1,6		100,0	89,0	70,0	54,0	37,3	-	-	96,0	158,5	169,3
EVM 32 5-0F5/11	15	11	160M	1,6		110,0	100,0	84,0	67,0	49,0	-	-	96,0	158,5	169,3
EVM 32 6-3F5/11	15	11	160M	1,6		122,0	109,0	87,0	67,5	47,0	-	-	99,0	161,5	172,3
EVM 32 6-2F5/11	15	11	160M	1,6		125,0	113,0	91,5	71,5	51,0	-	-	99,0	161,5	172,3
EVM 32 7-3F5/15	20	15	160M	1,6		144,0	129,0	104,0	81,0	57,0	-	-	102,0	189,1	206
EVM 32 7-0F5/15	20	15	160M	1,6		154,0	141,0	118,0	94,0	69,0	-	-	102,0	189,1	206
EVM 32 8-3F5/15	20	15	160M	2,5		166,0	150,0	121,0	94,0	67,0	-	-	105,0	192,1	209
EVM 32 8-2F5/15	20	15	160M	2,5		172,0	157,0	130,0	103,0	75,0	-	-	105,0	192,1	209
EVM 32 9-3F5/18.5	25	18,5	160L	2,5		188,0	170,0	137,0	108,0	76,5	-	-	108,0	205,5	212
EVM 32 9-0F5/18.5	25	18,5	160L	2,5		197,0	181,0	152,0	121,0	88,5	-	-	108,0	205,5	212
EVM 32 10-3F5/18.5	25	18,5	160L	2,5		210,0	190,0	154,0	121,0	86,5	-	-	112,0	209,5	216
EVM 32 10-2F5/18.5	25	18,5	160L	2,5		213,0	193,0	159,0	125,0	90,5	-	-	112,0	209,5	216
EVM 32 11-3F5/22	30	22	180	2,5		232,0	210,0	171,0	134,0	96,5	-	-	116,0	279,0	286
EVM 32 11-0F5/22	30	22	180	2,5		241,0	221,0	185,0	147,0	108,0	-	-	116,0	279,0	286
EVM 32 12-3F5/22	30	22	180	2,5		254,0	230,0	188,0	148,0	106,0	-	-	119,0	282,0	289
EVM 32 13-3F5/30	40	30	200	3,0		276,0	250,0	205,0	161,0	116,0	-	-	129,0	357,0	-
EVM 32 13-0F5/30	40	30	200	3,0		285,0	261,0	219,0	174,0	128,0	-	-	129,0	357,0	-
EVM 32 14-3F5/30	40	30	200	3,0		298,0	270,0	222,0	175,0	126,0	-	-	133,0	361,0	-
EVM 32 14-0F5/30	40	30	200	3,0		307,0	281,0	236,0	188,0	138,0	-	-	133,0	361,0	-
EVM 45 1-1F5/3.0	4	3	100	1,6		-	18,9	17,6	16,3	14,3	8,3	-	71,0	93,8	-
EVM 45 1-0F5/4.0	5,5	4	112	1,6		-	25,6	24,6	23,5	21,8	16,7	13,3	73,0	95,8	-
EVM 45 2-2F5/5.5	7,5	5,5	132S	1,6		-	38,1	35,8	33,4	29,8	18,6	-	81,0	119,6	-
EVM 45 2-0F5/7.5	10	7,5	132S	1,6		-	51,5	50,0	48,0	45,0	35,4	29,1	81,0	121,4	123,4
EVM 45 3-2F5/11	15	11	160M	1,6		-	64,0	61,0	58,0	53,0	37,3	-	99,0	161,5	172,3
EVM 45 3-0F5/11	15	11	160M	1,6		-	77,5	75,0	72,5	68,0	54,0	45,0	99,0	161,5	172,3
EVM 45 4-2F5/15	20	15	160M	1,6		-	90,0	86,0	82,0	76,0	56,0	43,0	108,0	195,1	212
EVM 45 4-0F5/15	20	15	160M	1,6		-	103,0	100,0	96,5	91,0	73,0	60,5	108,0	195,1	212
EVM 45 5-2F5/18.5	25	18,5	160L	1,6		-	116,0	111,0	107,0	99,0	74,5	58,5	128,0	225,5	232
EVM 45 5-0F5/18.5	25	18,5	160L	1,6		-	129,0	125,0	121,0	114,0	91,5	76,5	128,0	225,5	232
EVM 45 6-2F5/22	30	22	180	1,6		-	142,0	137,0	131,0	122,0	93,5	74,5	133,0	296,0	303
EVM 45 6-0F5/22	30	22	180	1,6		-	155,0	151,0	146,0	137,0	110,0	92,5	133,0	296,0	303
EVM 45 7-2F5/30	40	30	200	2,5		-	168,0	162,0	155,0	145,0	112,0	90,5	139,0	367,0	-
EVM 45 7-0F5/30	40	30	200	2,5		-	181,0	176,0	170,0	160,0	129,0	108,0	139,0	367,0	-
EVM 45 8-2F5/30	40	30	200	2,5		-	194,0	187,0	180,0	168,0	131,0	106,0	146,0	374,0	-
EVM 45 8-0F5/30	40	30	200	2,5		-	207,0	201,0	194,0	183,0	148,0	124,0	146,0	374,0	-
EVM 45 9-2F5/30	40	30	200	2,5		-	219,0	212,0	204,0	191,0	150,0	122,0	151,0	379,0	-
EVM 45 9-0F5/37	50	37	200	2,5		-	233,0	226,0	219,0	206,0	166,0	140,0	151,0	393,0	-
EVM 45 10-2F5/37	50	37	200	3,0		-	245,0	237,0	229,0	214,0	168,0	138,0	156,0	398,0	-
EVM 45 10-0F5/37	50	37	200	3,0		-	259,0	251,0	243,0	229,0	185,0	156,0	156,0	398,0	-

1,6 MPa= 16 bar
2,5 MPa= 25 bar
3,0 MPa= 30 bar

[1]= Only for IE3 motors

VERTICAL MULTISTAGE ELECTRIC PUMPS

in cast iron, AISI 304, AISI 316

PERFORMANCE TABLE EVM 64

Model	P ₂		Motor Mec	Max. working pressure [MPa]	Q=Flow rate								Weight [kg]		
	[HP]	[kW]			l/min	500	600	700	900	1000	1200	1400	Pump	Pump + Motor	
					m ³ /h	30	36	42	54	60	72	84		[1]	
						H=Head [m]									
EVM 64 1-1F5/4.0	5,5	4	100	1,6		21,0	20,4	19,7	17,5	15,9	11,4	-	70,4	93,2	-
EVM 64 1-0F5/5.5	7,5	5,5	132S	1,6		26,6	26,1	25,4	23,7	22,3	18,5	13,5	77,0	115,6	-
EVM 64 2-2F5/7.5	10	7,5	132S	1,6		42,5	41,5	40,5	36,5	33,5	25,3	-	81,4	121,8	123,8
EVM 64 2-1F5/11	15	11	160M	1,6		48,0	47,0	46,0	42,5	40,0	32,4	23,0	93,5	156,0	166,8
EVM 64 2-0F5/11	15	11	160M	1,6		53,5	53,0	52,0	49,0	46,5	39,5	30,6	93,5	156,0	166,8
EVM 64 3-3F5/15	20	15	160M	1,6		64,0	62,5	61,0	55,5	51,0	39,3	-	99,0	186,1	203
EVM 64 3-2F5/15	20	15	160M	1,6		69,5	68,0	66,5	61,5	57,5	46,5	32,5	99,0	186,1	203
EVM 64 3-1F5/15	20	15	160M	1,6		75,0	74,0	72,5	68,0	64,0	53,5	40,0	99,0	186,1	203
EVM 64 3-0F5/18.5	25	18,5	160L	1,6		80,5	79,5	78,0	74,0	70,5	60,5	47,5	99,0	196,5	203
EVM 64 4-3F5/18.5	25	18,5	160L	1,6		91,0	89,0	87,0	80,5	75,5	60,5	42,0	108,0	205,5	212
EVM 64 4-2F5/18.5	25	18,5	160L	1,6		96,5	95,0	93,0	87,0	81,5	67,5	49,5	108,0	205,5	212
EVM 64 4-1F5/22	30	22	180	1,6		102,0	101,0	98,5	93,0	88,0	74,5	57,0	116,0	279,0	286
EVM 64 4-0F5/22	30	22	180	1,6		108,0	106,0	104,0	99,0	94,5	81,5	64,5	116,0	279,0	286
EVM 64 5-3F5/30	40	30	200	1,6		118,0	116,0	114,0	106,0	99,5	81,5	59,0	128,0	356,0	-
EVM 64 5-2F5/30	40	30	200	1,6		124,0	122,0	119,0	112,0	106,0	88,5	66,5	128,0	356,0	-
EVM 64 5-1F5/30	40	30	200	1,6		129,0	127,0	125,0	118,0	112,0	95,5	74,0	128,0	356,0	-
EVM 64 5-0F5/30	40	30	200	1,6		135,0	133,0	131,0	124,0	119,0	103,0	81,5	128,0	356,0	-
EVM 64 6-3F5/30	40	30	200	1,6		145,0	143,0	140,0	131,0	124,0	103,0	76,0	136,0	364,0	-
EVM 64 6-2F5/30	40	30	200	2,5		151,0	148,0	146,0	137,0	130,0	110,0	83,5	136,0	364,0	-
EVM 64 6-1F5/37	50	37	200	2,5		156,0	154,0	151,0	143,0	136,0	117,0	91,0	136,0	378,0	-
EVM 64 6-0F5/37	50	37	200	2,5		162,0	160,0	157,0	149,0	143,0	124,0	99,0	136,0	378,0	-
EVM 64 7-3F5/37	50	37	200	2,5		172,0	169,0	166,0	156,0	148,0	124,0	93,0	139,0	381,0	-
EVM 64 7-2F5/37	50	37	200	2,5		178,0	175,0	172,0	162,0	154,0	131,0	101,0	139,0	381,0	-
EVM 64 7-1F5/37	50	37	200	2,5		183,0	181,0	178,0	168,0	161,0	138,0	108,0	139,0	381,0	-

1,6 MPa= 16 bar
2,5 MPa= 25 bar

[1] Commercial

I contenuti della presente pubblicazione non devono essere considerati impegnativi. EBARA Pumps Europe S.p.A. si riserva il diritto di apportare senza preavviso le modifiche che ritenga più opportune.



EVM

VERTICAL MULTISTAGE ELECTRIC PUMPS

in cast iron, AISI 304, AISI 316

PERFORMANCE CURVES EVM 3 (according to ISO 9906 Attachment A)

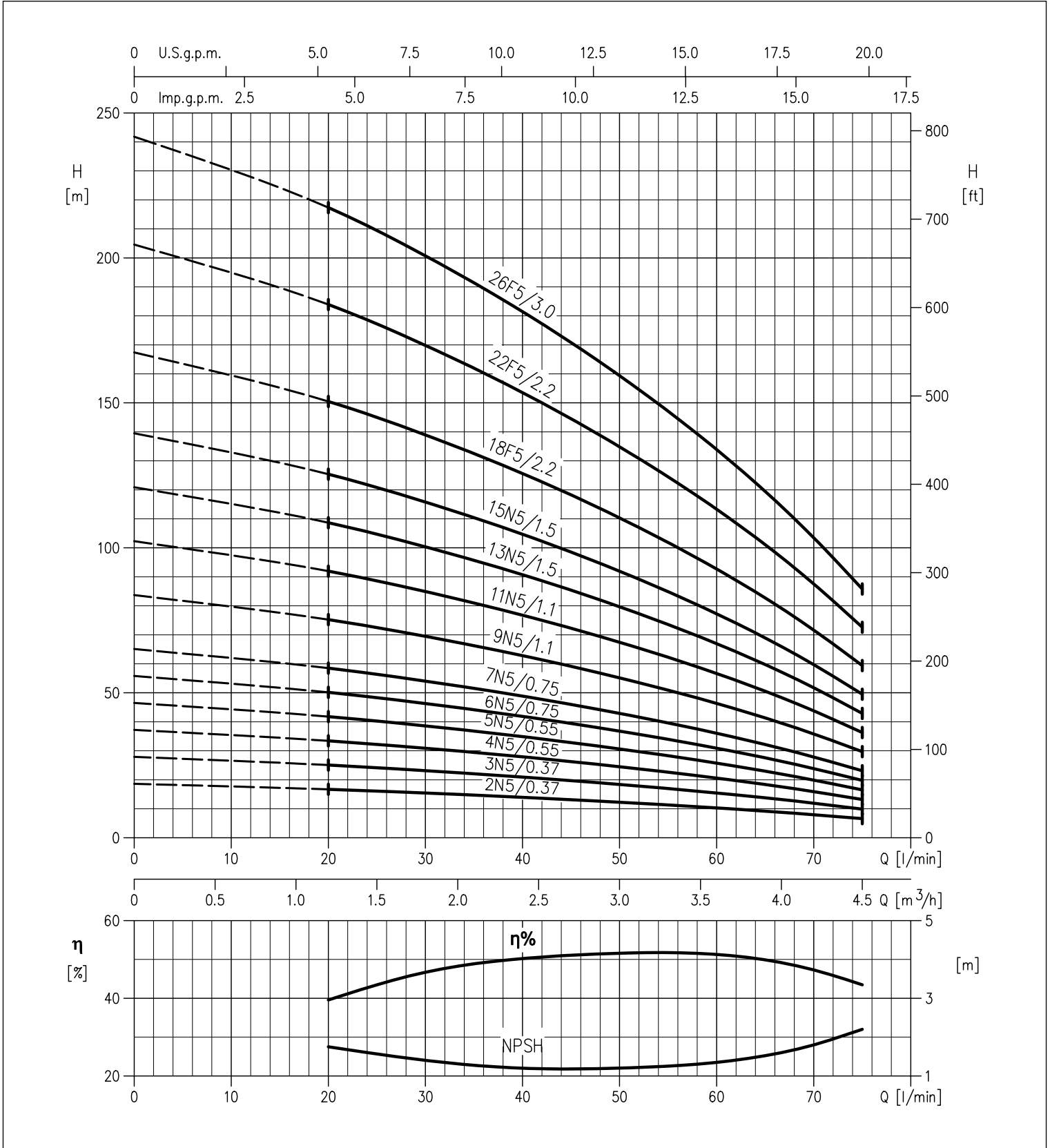

I contenuti della presente pubblicazione non devono essere considerati ingrativati. EBARA Pumps Europe Sp. A. si riserva il diritto di apportare senza preavviso le modifiche che riterrà più opportune.



EVM

VERTICAL MULTISTAGE ELECTRIC PUMPS

in cast iron, AISI 304, AISI 316

PERFORMANCE CURVES EVM 5 (according to ISO 9906 Attachment A)

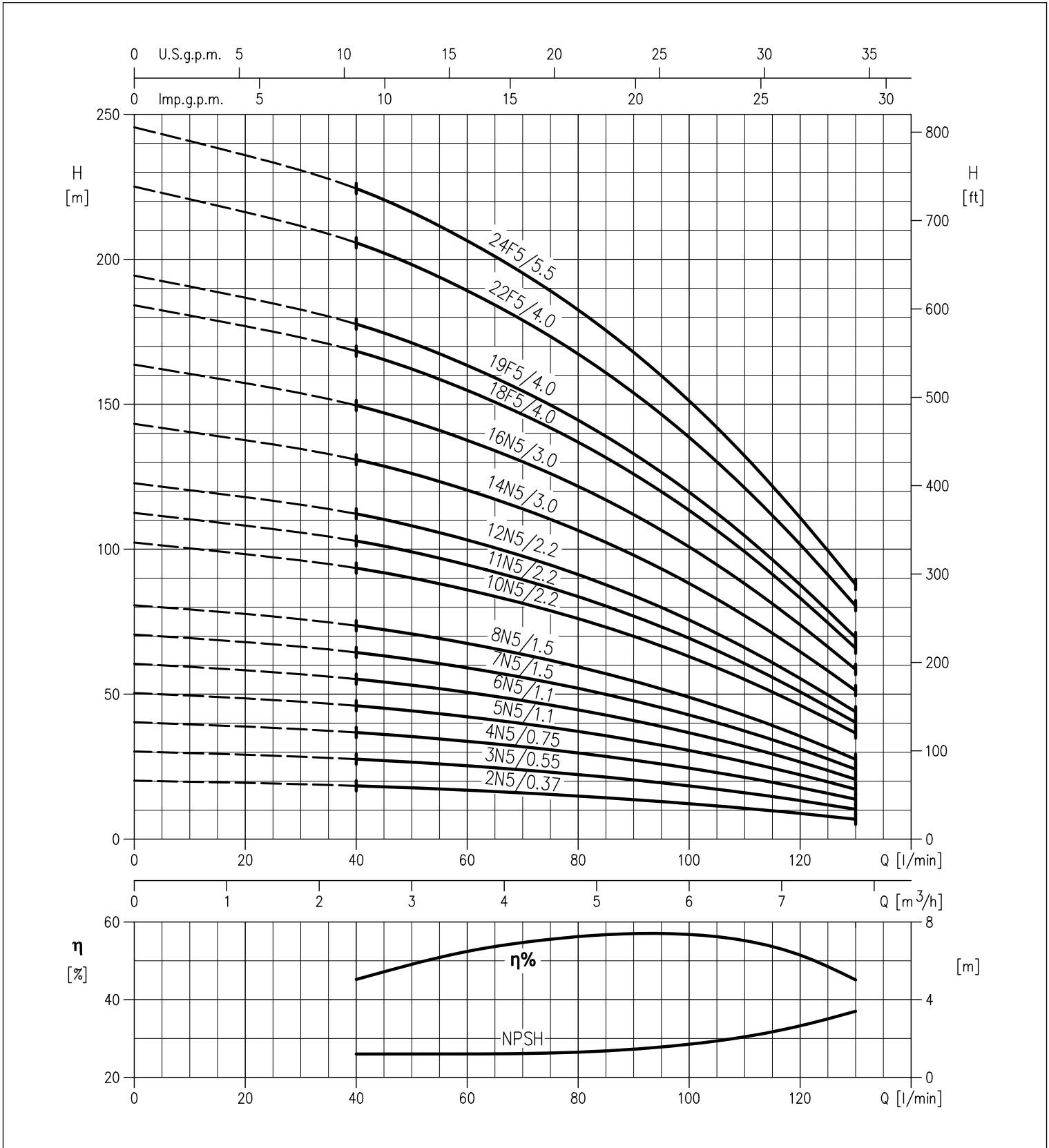

VERTICAL MULTISTAGE ELECTRIC PUMPS

in cast iron, AISI 304, AISI 316

PERFORMANCE CURVES EVM 10 (according to ISO 9906 Attachment A)

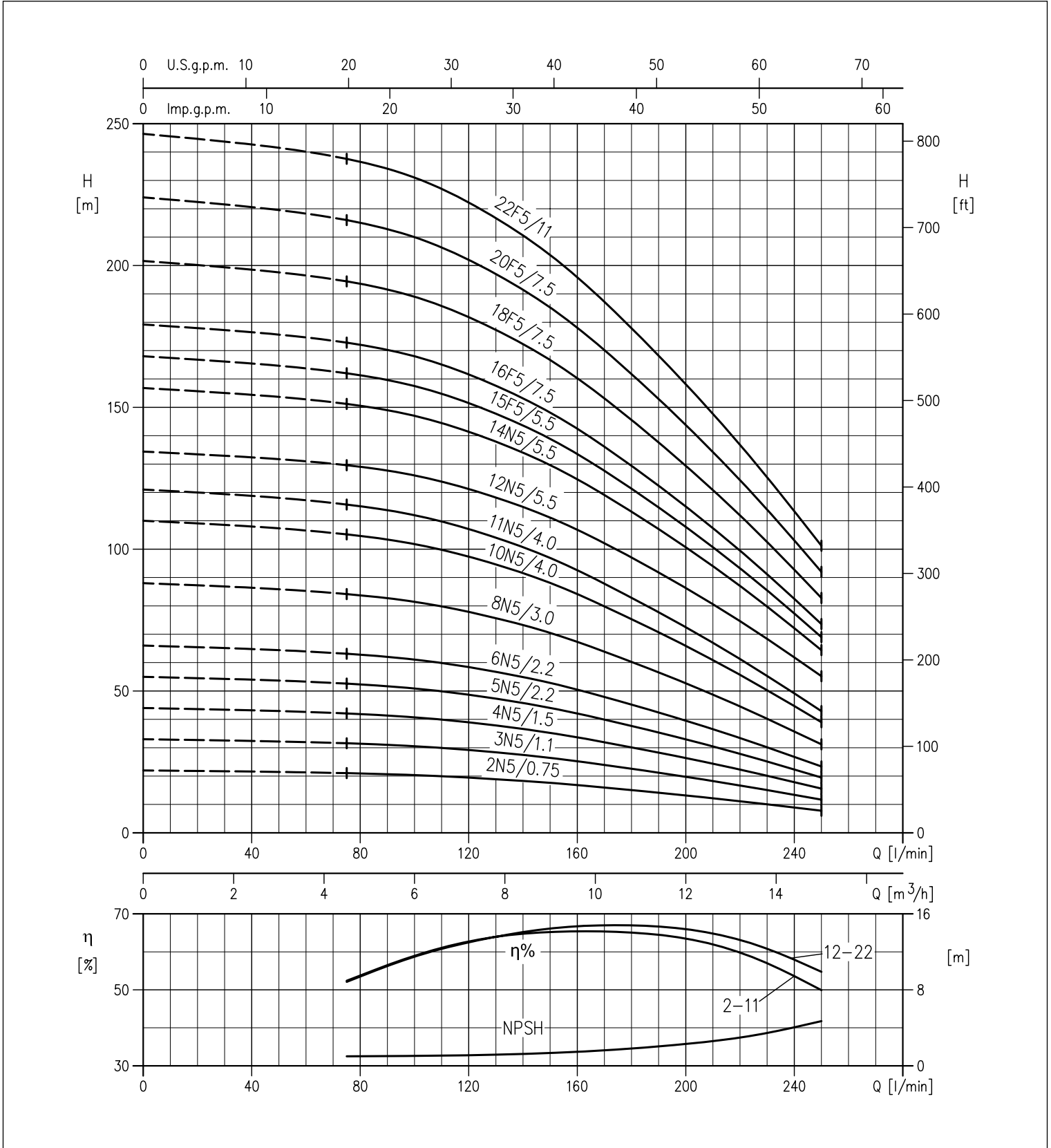

VERTICAL MULTISTAGE ELECTRIC PUMPS

in cast iron, AISI 304, AISI 316

PERFORMANCE CURVES EVM 18 (according to ISO 9906 Attachment A)

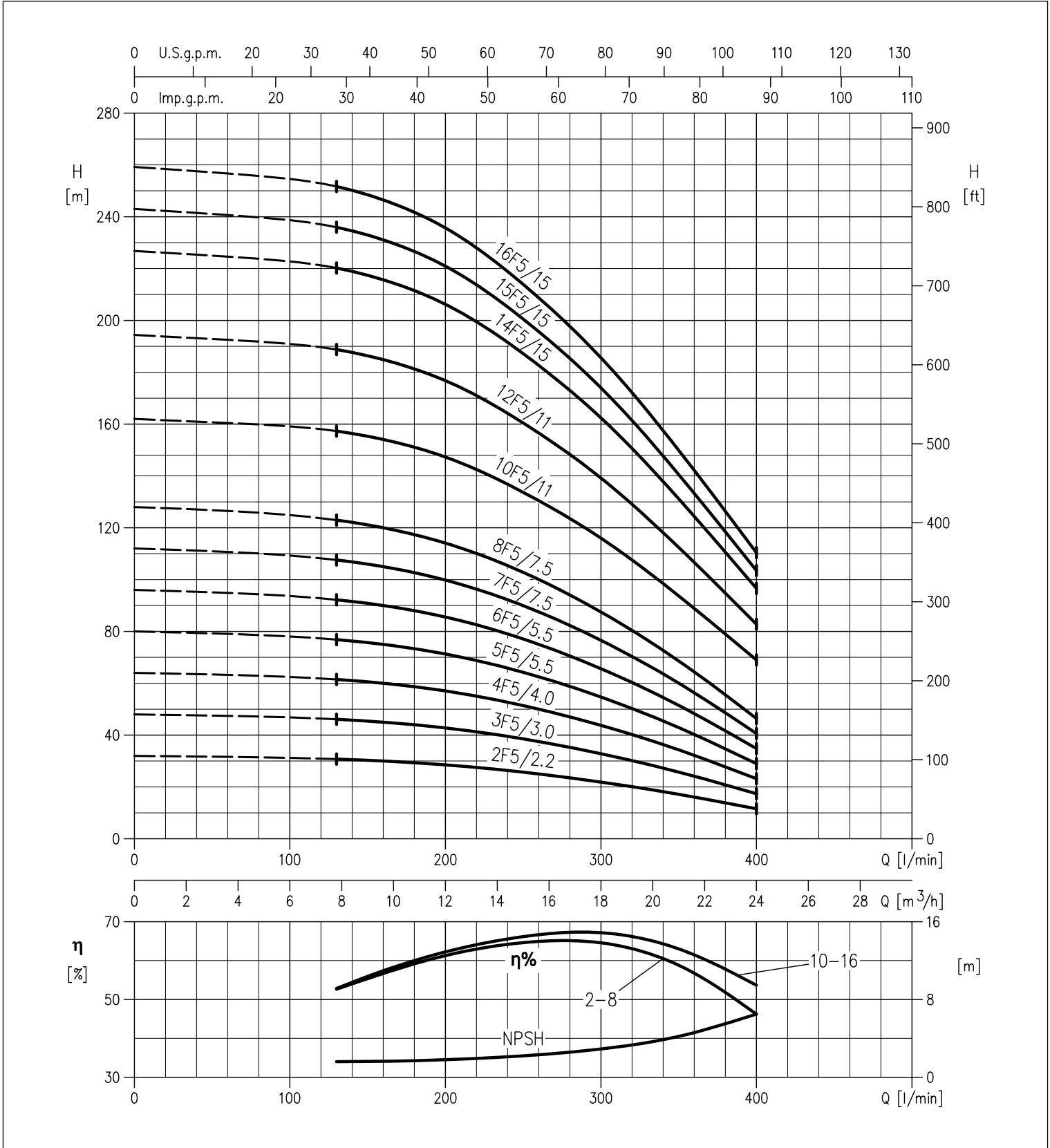



EVM

VERTICAL MULTISTAGE ELECTRIC PUMPS

in cast iron, AISI 304, AISI 316

PERFORMANCE CURVES EVM 32 (according to ISO 9906 Attachment A)

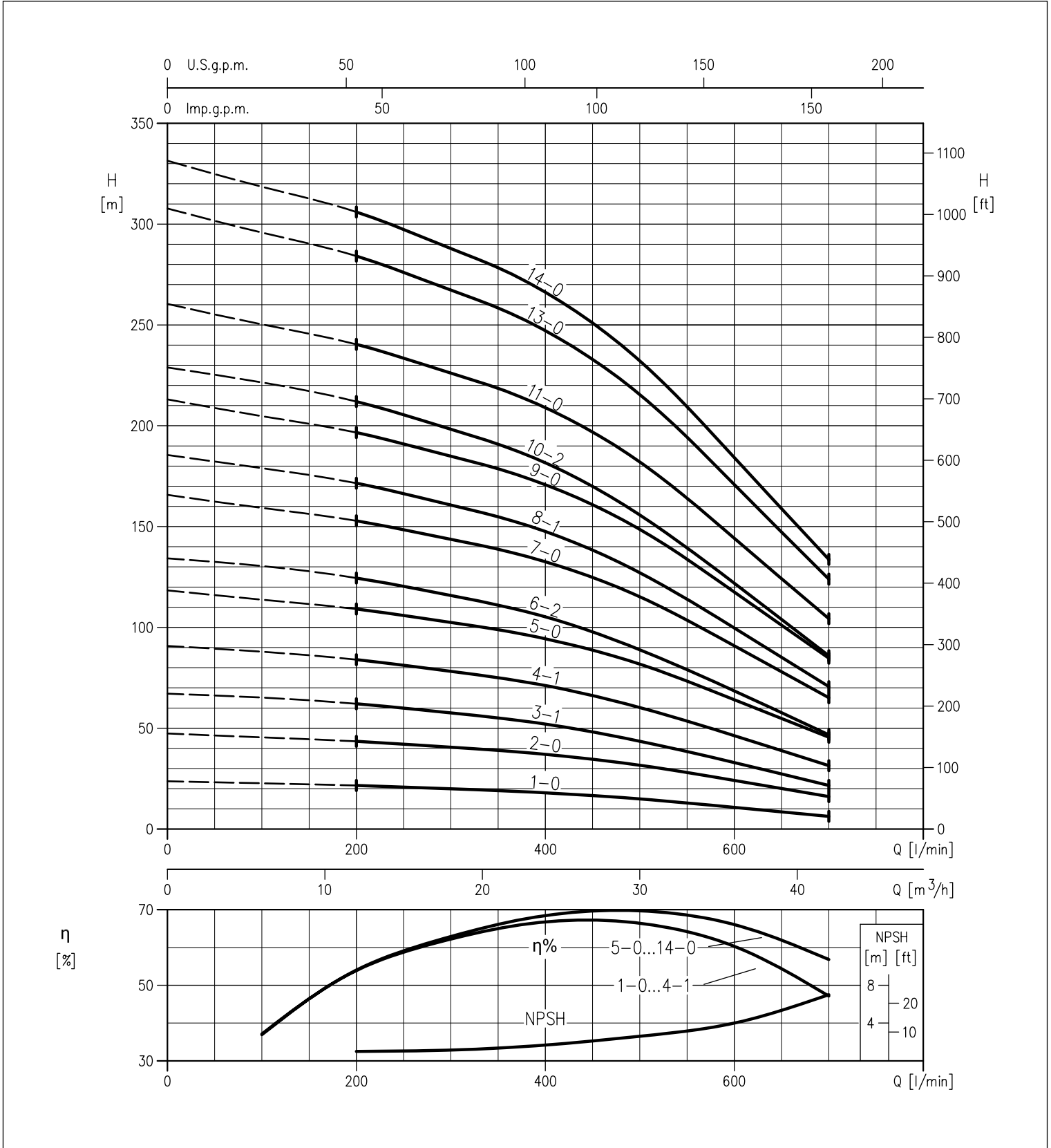

I contenuti della presente pubblicazione non devono essere considerati ingratificati. EBARA Pumps Europe Sp. A. si riserva il diritto di apportare senza preavviso le modifiche che riterrà più opportune.

VERTICAL MULTISTAGE ELECTRIC PUMPS

in cast iron, AISI 304, AISI 316

PERFORMANCE CURVES EVM 32 (according to ISO 9906 Attachment A)

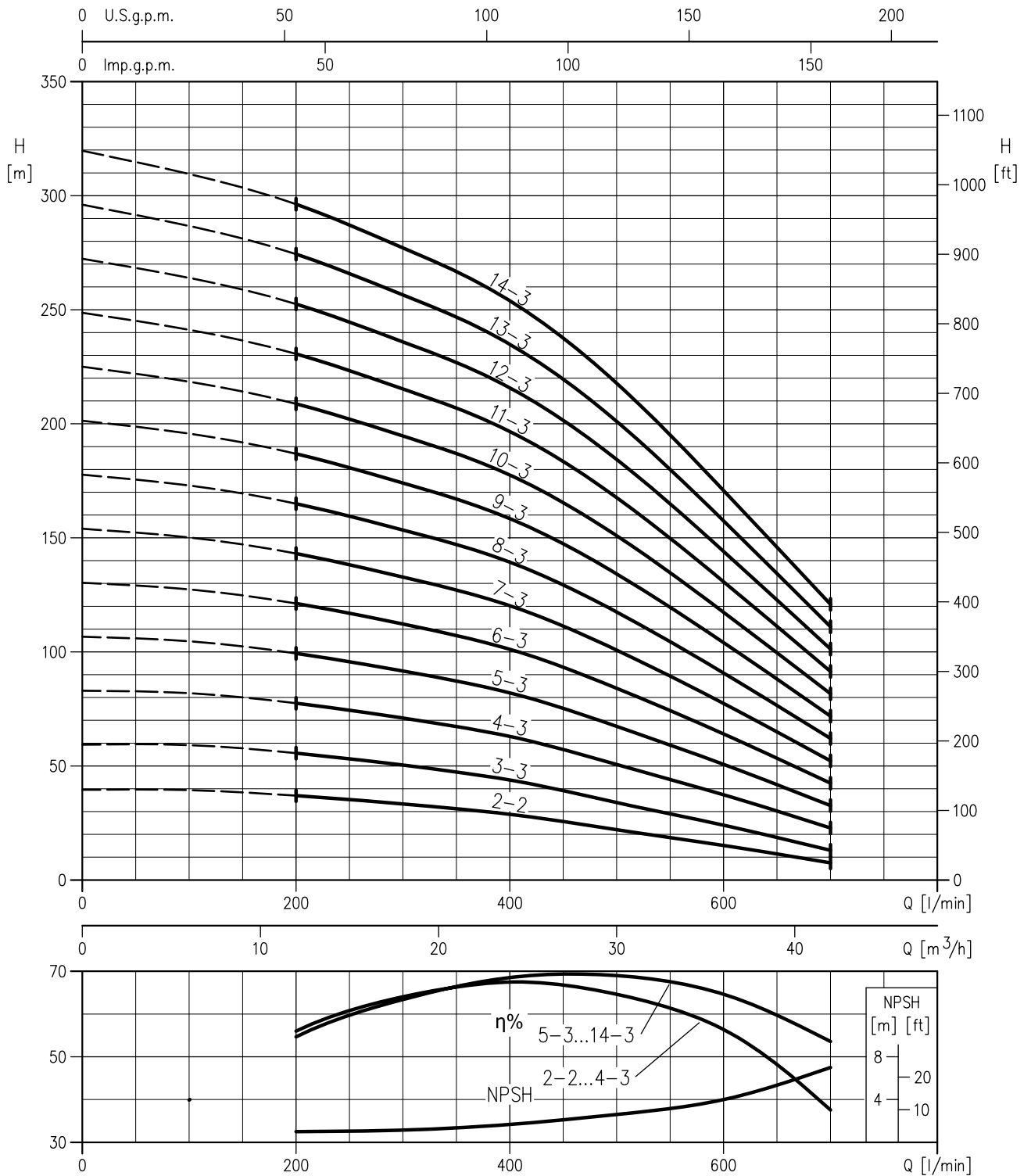

I contenuti della presente pubblicazione non devono essere considerati ingratificati. EBARA Pumps Europa S.p.A. si riserva il diritto di apportare senza preavviso le modifiche che ritenga più opportune.

VERTICAL MULTISTAGE ELECTRIC PUMPS

in cast iron, AISI 304, AISI 316

PERFORMANCE CURVES EVM 45 (according to ISO 9906 Attachment A)

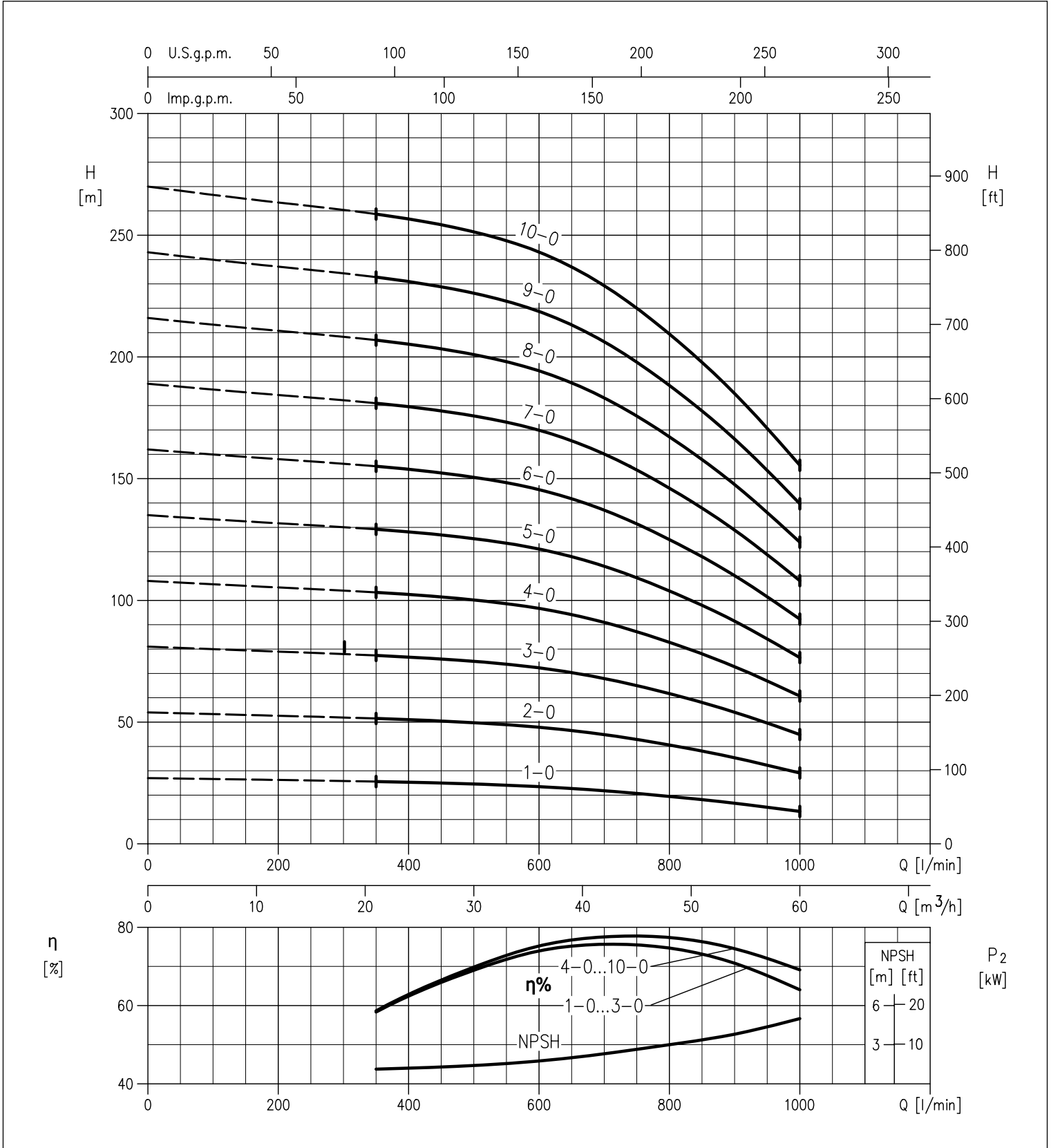



EVM

VERTICAL MULTISTAGE ELECTRIC PUMPS

in cast iron, AISI 304, AISI 316

PERFORMANCE CURVES EVM 45 (according to ISO 9906 Attachment A)

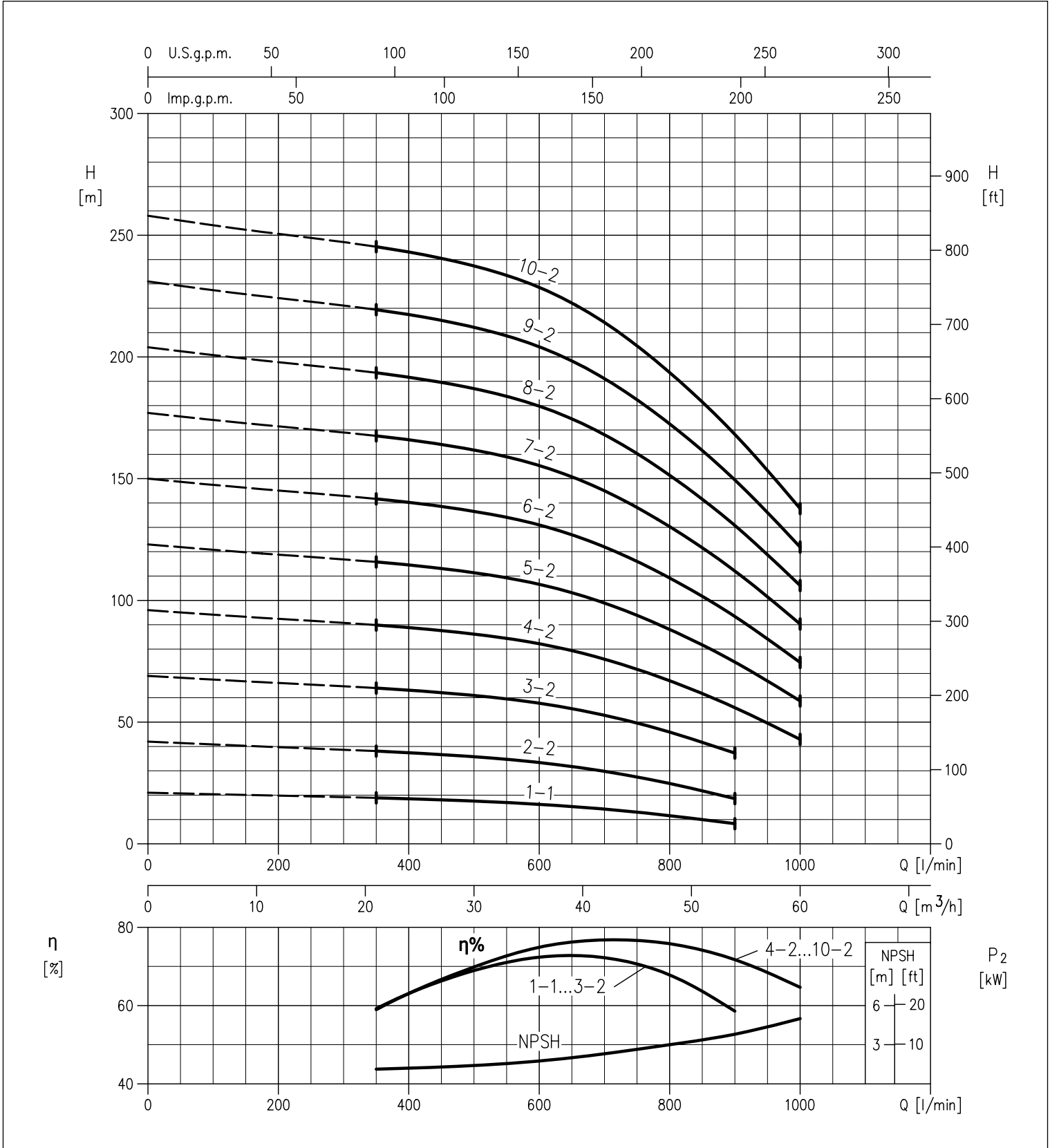



EVM

VERTICAL MULTISTAGE ELECTRIC PUMPS

in cast iron, AISI 304, AISI 316

PERFORMANCE CURVES EVM 64 (according to ISO 9906 Attachment A)

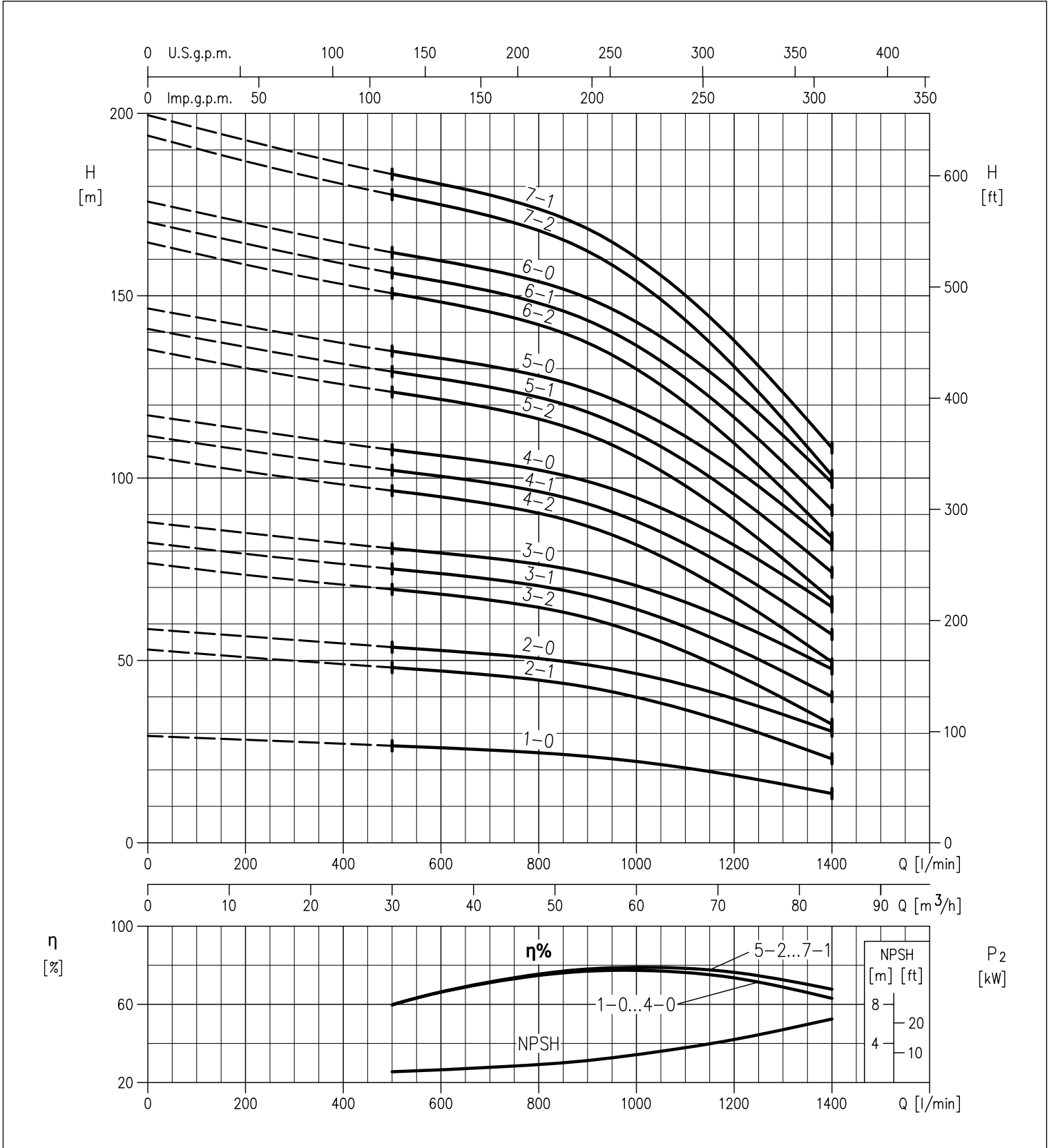

I contenuti della presente pubblicazione non devono essere considerati ingratificati. EBARA Pumps Europe Sp. A. si riserva il diritto di apportare senza preavviso le modifiche che riterrà più opportune.

VERTICAL MULTISTAGE ELECTRIC PUMPS

in cast iron, AISI 304, AISI 316

PERFORMANCE CURVES EVM 64 (according to ISO 9906 Attachment A)

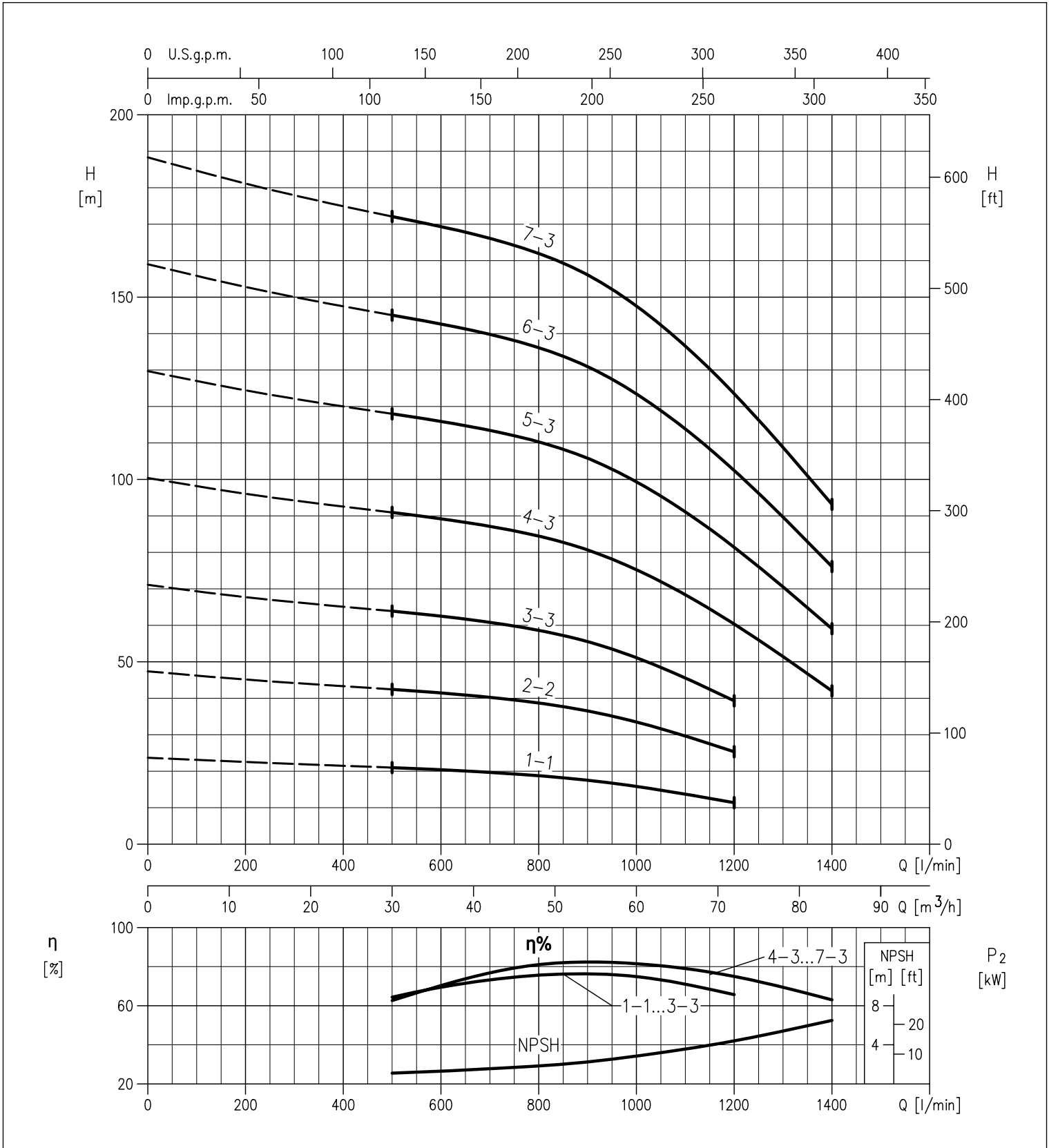

VERTICAL MULTISTAGE ELECTRIC PUMPS

in cast iron, AISI 304, AISI 316

DIMENSIONS EVM 3-5-10-18

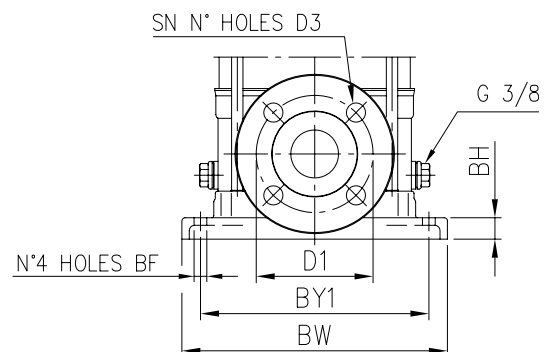
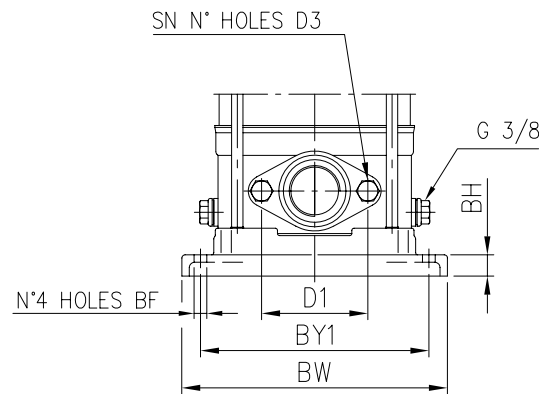
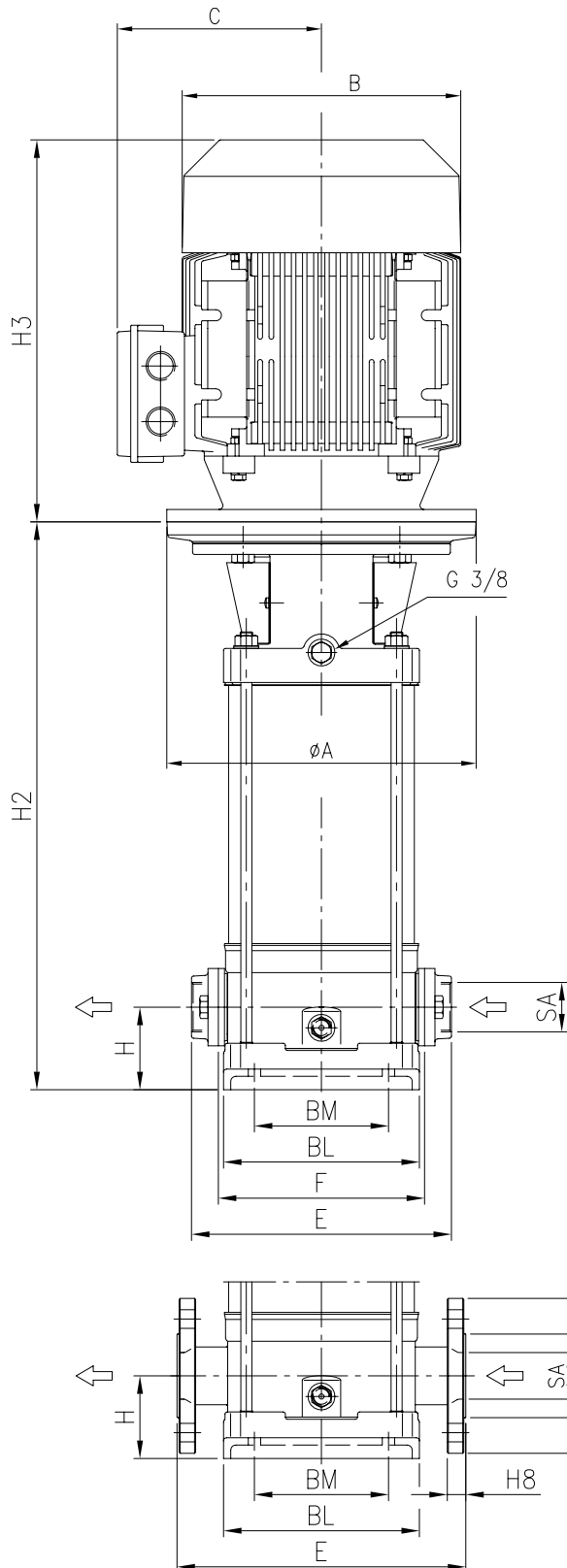

VERTICAL MULTISTAGE ELECTRIC PUMPS

in cast iron, AISI 304, AISI 316

DIMENSIONS EVM 32-45-64

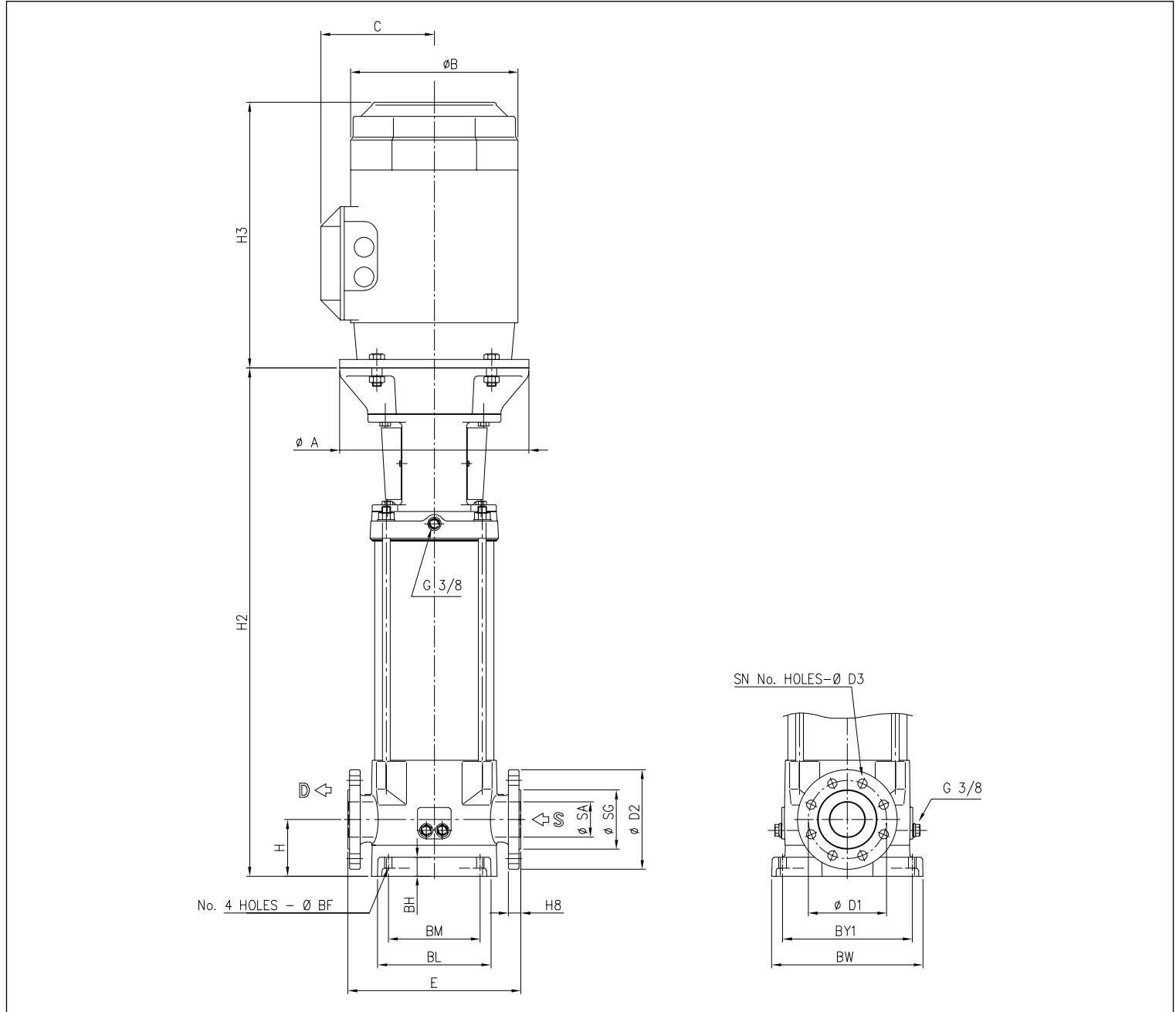

Model	Mot. Mec	P. max. [MPa]	Dimensions [mm]																	Weight [kg]					
			H	H2	H3 [1]	E	B [1]	C [1]	BM	BL	BY1	BW	SA	SG	D1	D2	H8	SN	D3	BF	BH	A	Pump	Pump+Motor [*]	
32 1-0F5/2.2	90L	1,6	105	493	267	320	180	148	170	210	240	280	Ø65	Ø110	Ø145	Ø185	23	4	Ø18	Ø14	35	140	56	72	80,8
32 2-2F5/3.0	100L	1,6	105	503	306	320	196	155	170	210	240	280	Ø65	Ø110	Ø145	Ø185	23	4	Ø18	Ø14	35	160	58	80,8	84,5
32 2-0F5/4.0	112M	1,6	105	503	306	320	196	155	170	210	240	280	Ø65	Ø110	Ø145	Ø185	23	4	Ø18	Ø14	35	160	58	80,8	112,6
32 3-3F5/5.5	132S	1,6	105	572	328	320	220	161	170	210	240	280	Ø65	Ø110	Ø145	Ø185	23	4	Ø18	Ø14	35	300	74	112,6	112,6
32 3-1F5/5.5	132S	1,6	105	572	328	320	220	161	170	210	240	280	Ø65	Ø110	Ø145	Ø185	23	4	Ø18	Ø14	35	300	74	112,6	119,4
32 4-3F5/7.5	132S	1,6	105	620	328	320	220	161	170	210	240	280	Ø65	Ø110	Ø145	Ø185	23	4	Ø18	Ø14	35	300	77	-	119,4
32 4-1F5/7.5	132S	1,6	105	620	328	320	220	161	170	210	240	280	Ø65	Ø110	Ø145	Ø185	23	4	Ø18	Ø14	35	300	77	-	169,3
32 5-3F5/11	160M	1,6	105	799	403	320	248	195	170	210	240	280	Ø65	Ø110	Ø145	Ø185	23	4	Ø18	Ø14	35	350	96	-	169,3
32 5-0F5/11	160M	1,6	105	799	403	320	248	195	170	210	240	280	Ø65	Ø110	Ø145	Ø185	23	4	Ø18	Ø14	35	350	96	-	169,3

[1]= Only for IE3 motors

VERTICAL MULTISTAGE ELECTRIC PUMPS

in cast iron, AISI 304, AISI 316

VISTA IN SEZIONE EVM(L) 3-18 Pump without bearings

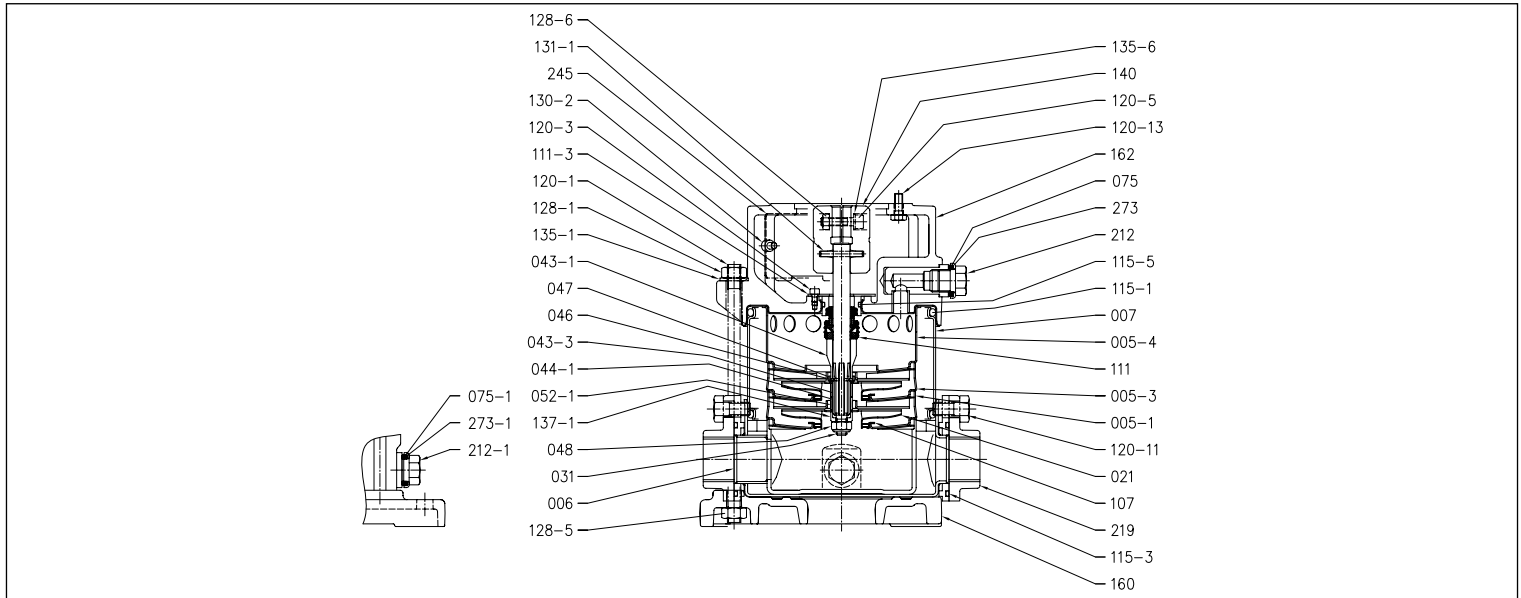

VISTA IN SEZIONE EVM(L) 3-18 Pump with single ball bearings

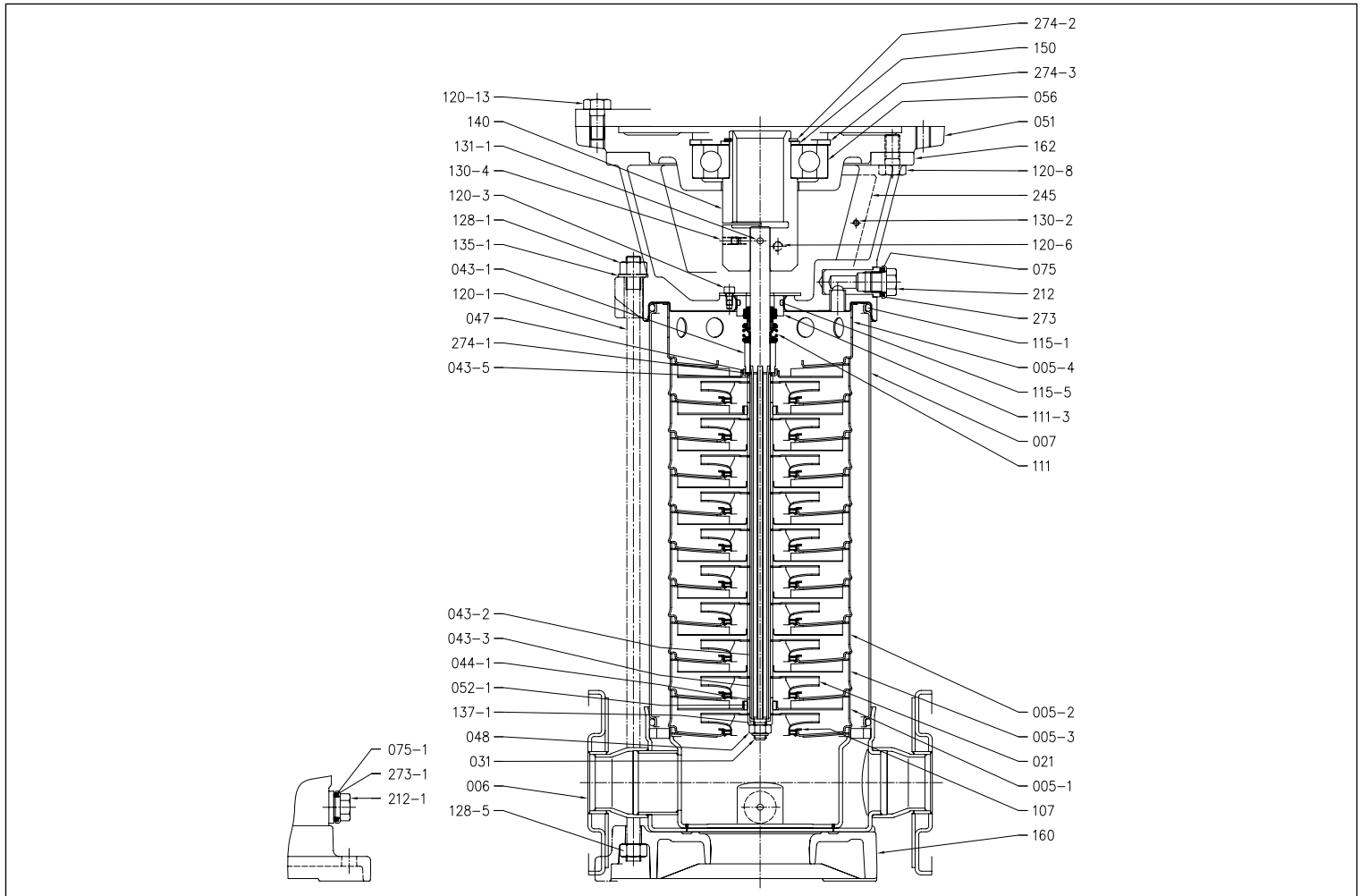

VERTICAL MULTISTAGE ELECTRIC PUMPS

in cast iron, AISI 304, AISI 316

TABELLA MATERIALI EVM(L) 3-18

Rif.	Nome	Materiale	
		EVM	EVML
005-1	Suction stage	EN 1.4301(AISI 304)	EN 1.4401 (AISI 316)
005-2	Intermediate stage	EN 1.4301(AISI 304)	EN 1.4401 (AISI 316)
005-3	Support stage kit	EN 1.4301(AISI 304)	EN 1.4401 (AISI 316)
005-4	Final stage	EN 1.4301(AISI 304)	EN 1.4401 (AISI 316)
006	Pump casing	EN 1.4301(AISI 304)	EN 1.4401 (AISI 316)
007	External casing	EN 1.4301(AISI 304)	EN 1.4401 (AISI 316)
021	Impeller	EN 1.4301(AISI 304)	EN 1.4401 (AISI 316)
031	Shaft	EN 1.4401 (AISI 316)	
044-1	Bearing	Tungsten Carbide	
048	Impeller nut	A2-70 UNI 7323 (with stainless steel insert)	A4-70 UNI 7323 (with stainless steel insert)
051	Motor adapter	Cast iron EN-GJL-200-EN 1561	
052-1	Bearing	Tungsten Carbide	
056	Bearing	-	
075	O-Ring	EPDM	FPM
107	Casing ring	PTFE/EN 1.4301(AISI 304)	PTFE/EN 1.4401 (AISI 316)
111	Mechanical seal	SiC/Carbon/EPDM	SiC/Carbon/FPM
115	O-Ring (external casing)	EPDM	FPM
	O-Ring (stage)	EPDM	FPM
	O-Ring (seal-holder flange)	EPDM	FPM
120-1	Joint screw	Galvanised steel 6.8 class ISO 898/1	
140	Joint	Die cast Aluminium EN AB-AISI11Cu2 (Fe) (up to 1.5kW)	
		Brass QT 58 UNI 5705 (from 2.2kW and above)	
160	Pump body base	Die cast Aluminium EN AB-AISI11Cu2 (Fe)	
162	Motor bracket	Cast iron + EN 1.4301(AISI 304)	Cast iron + EN 1.4401 (AISI 316)
212	Plug	EN 1.4301(AISI 304)	EN 1.4401 (AISI 316)
273	Washer	EN 1.4301(AISI 304)	EN 1.4401 (AISI 316)

Commercial

VERTICAL MULTISTAGE ELECTRIC PUMPS

in cast iron, AISI 304, AISI 316

VISTA IN SEZIONE EVM(L) 32 Pump without bearings

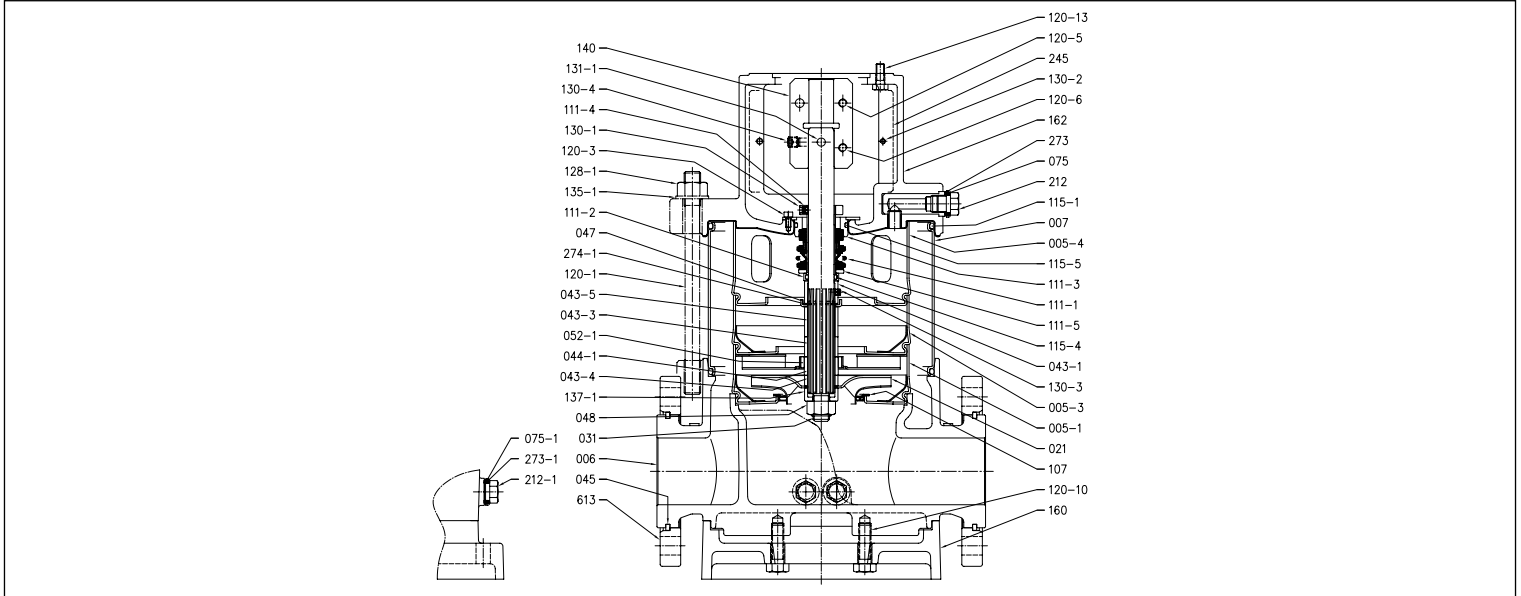

VISTA IN SEZIONE EVM(L) 32 Pump with single ball bearings

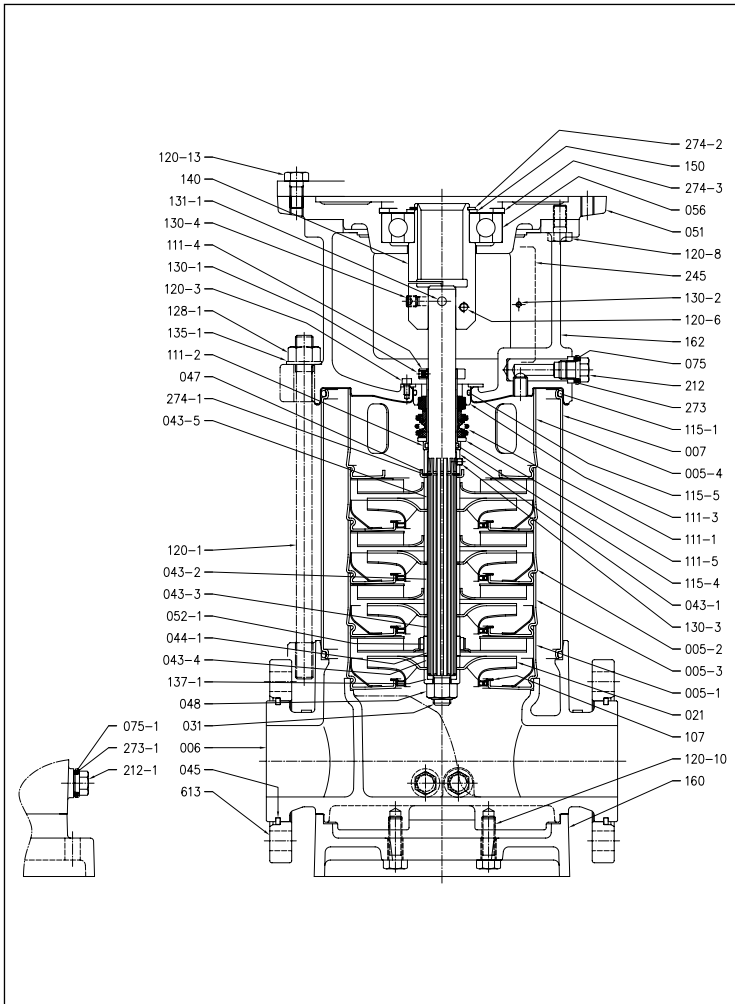

VISTA IN SEZIONE EVM(L) 32 Pump with double ball bearing

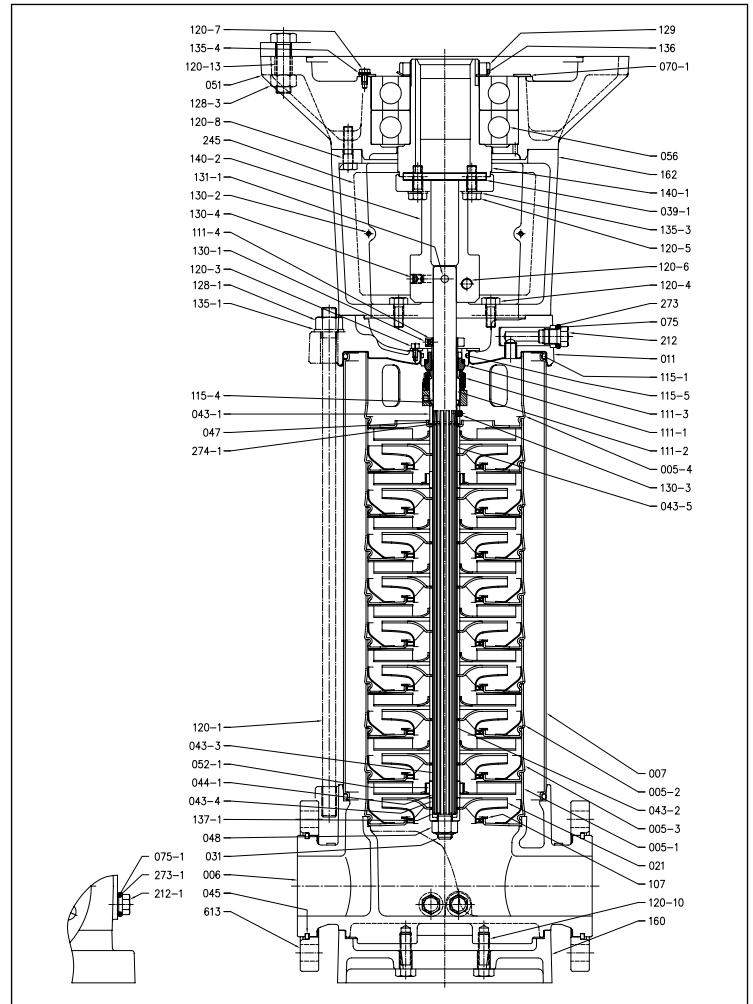

VERTICAL MULTISTAGE ELECTRIC PUMPS

in cast iron, AISI 304, AISI 316

TABELLA MATERIALI EVM(L) 32

Rif.	Nome	Materiale	
		EVM	EVML
005-1	Suction stage	EN 1.4301(AISI 304)	EN 1.4401 (AISI 316)
005-3	Support stage kit	EN 1.4301(AISI 304)	EN 1.4401 (AISI 316)
005-4	Final stage	EN 1.4301(AISI 304)	EN 1.4401 (AISI 316)
006	Pump casing	EN 1.4308 (ASTM CF8)	EN 1.4408 (ASTM CF8M)
007	External casing	EN 1.4301(AISI 304)	EN 1.4401 (AISI 316)
021	Impeller	EN 1.4301(AISI 304)	EN 1.4401 (AISI 316)
031	Shaft	EN 1.4301(AISI 304)	EN 1.4401 (AISI 316)
044-1	Bearing	Tungsten Carbide	
045	Flange half-ring	EN 1.402 (AISI 420)	
048	Impeller nut	A2-70 UNI 7323 (with stainless steel insert)	A4-70 UNI 7323 (with stainless steel insert)
052-1	Bearing	Tungsten Carbide	
056	Bearing	-	
075	O-Ring	EPDM	FPM
107	Casing ring	PTFE/EN 1.4301(AISI 304)	PTFE/EN 1.4401 (AISI 316)
111-1	Mechanical seal	SiC/Carbon/FPM	
111-2	Mechanical seal (cartridge)	EN 1.4301(AISI 304)	EN 1.4401 (AISI 316)
111-3	Mechanical seal seat	EN 1.4301(AISI 304)	EN 1.4401 (AISI 316)
111-4	Seal ring	Brass OT 58 UNI 5705	EN 1.4401 (AISI 316)
115	O-Ring (external casing)	EPDM	FPM
	O-Ring (stage)	EPDM	FPM
	O-Ring (seal-holder flange)	EPDM	FPM
	O-Ring (seal cover)	EPDM	FPM
120-1	Joint screw	Galvanised steel 6.8 class ISO 898/1	
130-1	Screw	A2-70 UNI 7323	
140	Joint	Brass OT 58 UNI 5705	
140-1	Joint motor	Carbon	
140-2	Joint	Carbon	
160	Pump body base	Cast iron EN-GJL-200-EN 1561	
162	Motor bracket	Cast iron EN-GJL-200-EN 1561	
212	Plug	EN 1.4301(AISI 304)	EN 1.4401 (AISI 316)
273	Washer	EN 1.4301(AISI 304)	EN 1.4401 (AISI 316)
613	Flange	Carbon	

VERTICAL MULTISTAGE ELECTRIC PUMPS

in cast iron, AISI 304, AISI 316

VISTA IN SEZIONE EVM(L) 45-64 Pump without bearings

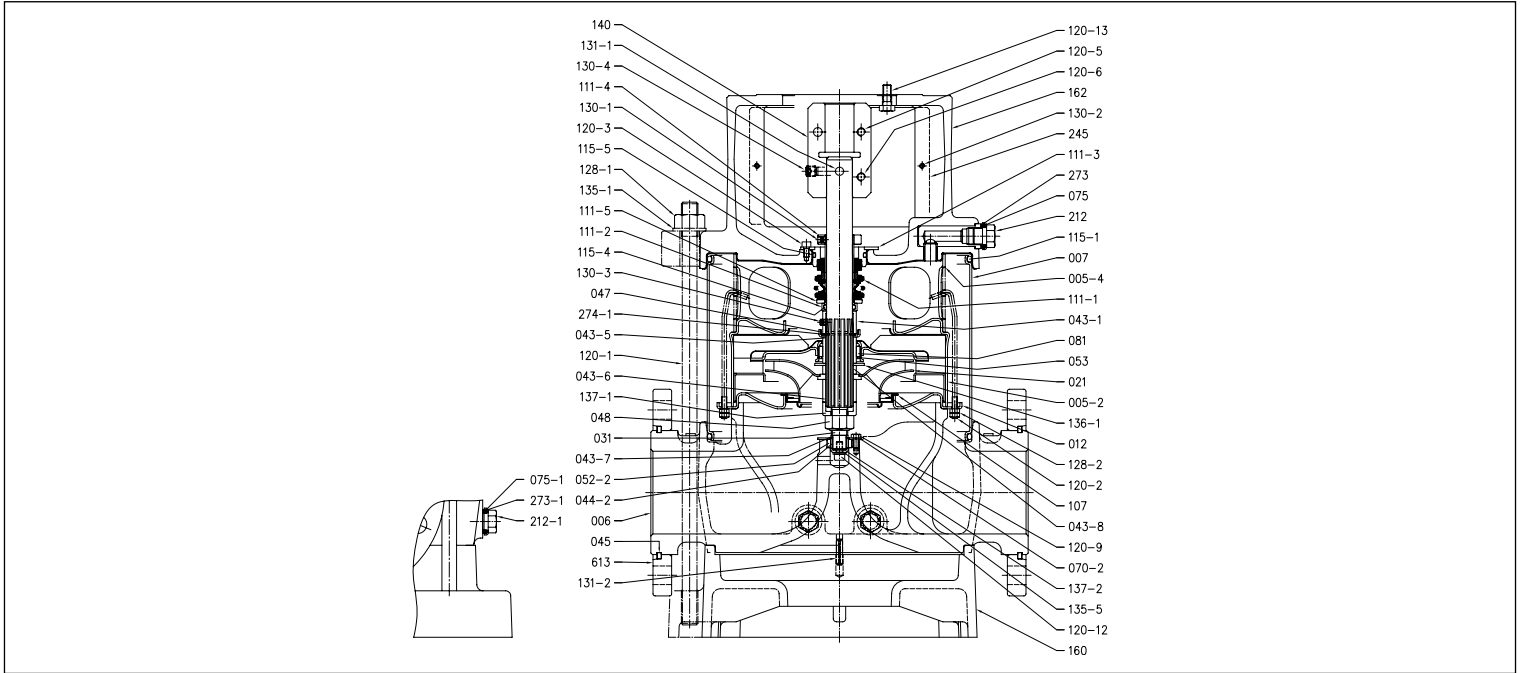

VISTA IN SEZIONE EVM(L) 45-64 Pump with single ball bearings

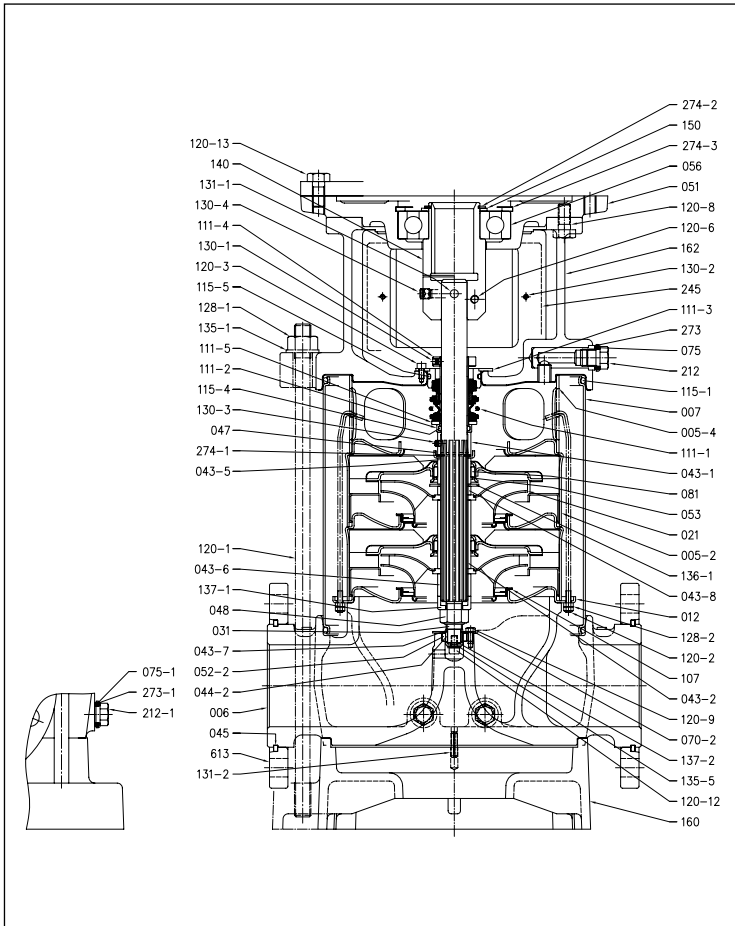

VISTA IN SEZIONE EVM(L) 45-64 Pump with double ball bearing

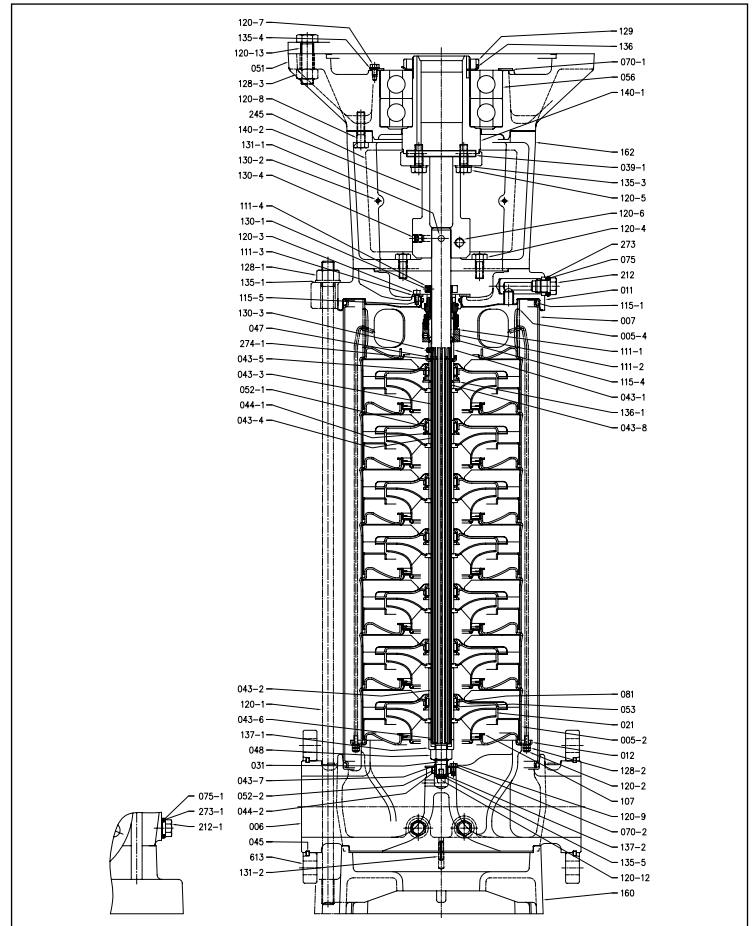

I contenuti della presente pubblicazione non devono essere considerati ingrativati. EBARA Pumps Europe Sp. A. si riserva il diritto di apportare senza preavviso le modifiche che ritenga più opportune.

VERTICAL MULTISTAGE ELECTRIC PUMPS

in cast iron, AISI 304, AISI 316

TABELLA MATERIALI EVM(L) 45-64

Rif.	Nome	Materiale	
		EVM	EVML
005-4	Final stage	EN 1.4301(AISI 304)	EN 1.4401 (AISI 316)
006	Pump casing	EN. 1.4308 (ASTM CF8)	EN. 1.4408 (ASTM CF8M)
007	External casing	EN 1.4301(AISI 304)	EN 1.4401 (AISI 316)
012	Suction cover	EN 1.4301(AISI 304)	EN 1.4401 (AISI 316)
021	Impeller	EN 1.4301(AISI 304)	EN 1.4401 (AISI 316)
031	Shaft		EN 1.4401 (AISI 316)
044-1	Bearing		Tungsten Carbide
044-2	Bearing		Tungsten Carbide
045	Flange half-ring		EN 1.402 (AISI 420)
048	Impeller nut	A2-70 UNI 7323 (with stainless steel insert)	A4-70 UNI 7323 (with stainless steel insert)
051	Motor adapter		Cast iron EN-GJL-200-EN 1561
052-2	Bearing		Tungsten Carbide
056	Bearing		-
075	O-Ring	EPDM	FPM
081	Bush		PTFE
107	Casing ring		PTFE/EN 1.4401 (AISI 316)
111-1	Mechanical seal		SiC/Carbon/FPM
111-2	Mechanical seal (cartridge)	EN 1.4301(AISI 304)	EN 1.4401 (AISI 316)
111-3	Mechanical seal seat	EN 1.4301(AISI 304)	EN 1.4401 (AISI 316)
111-4	Seal ring	Brass OT 58 UNI 5705	EN 1.4401 (AISI 316)
115-1	O-Ring (external casing)	EPDM	FPM
115-2	O-Ring (stage)	EPDM	FPM
115-4	O-Ring (seal-holder flange)	EPDM	FPM
115-5	O-Ring (seal cover)	EPDM	FPM
120-1	Joint screw		Galvanised steel 6.8 class ISO 898/1
120-2	Tie-rod	EN 1.4301(AISI 304)	EN 1.4401 (AISI 316)
128-2	Screw	Carbon	EN 1.4401 (AISI 316)
130-1	Screw		A2-70 UNI 7323
Commercial			Brass OT 58 UNI 5705
140-1	Joint motor		Carbon
140-2	Joint		Carbon
160	Pump body base		Cast iron EN-GJL-200 EN1561
162	Motor bracket		Cast iron EN-GJL-200-EN1561
212	Plug	EN 1.4301(AISI 304)	EN 1.4401 (AISI 316)
273	Washer	EN 1.4301(AISI 304)	EN 1.4401 (AISI 316)
613	Flange		Carbon

VERTICAL MULTISTAGE ELECTRIC PUMPS

in cast iron, AISI 304, AISI 316

VISTA IN SEZIONE EVMG 3-18 Pump without bearings

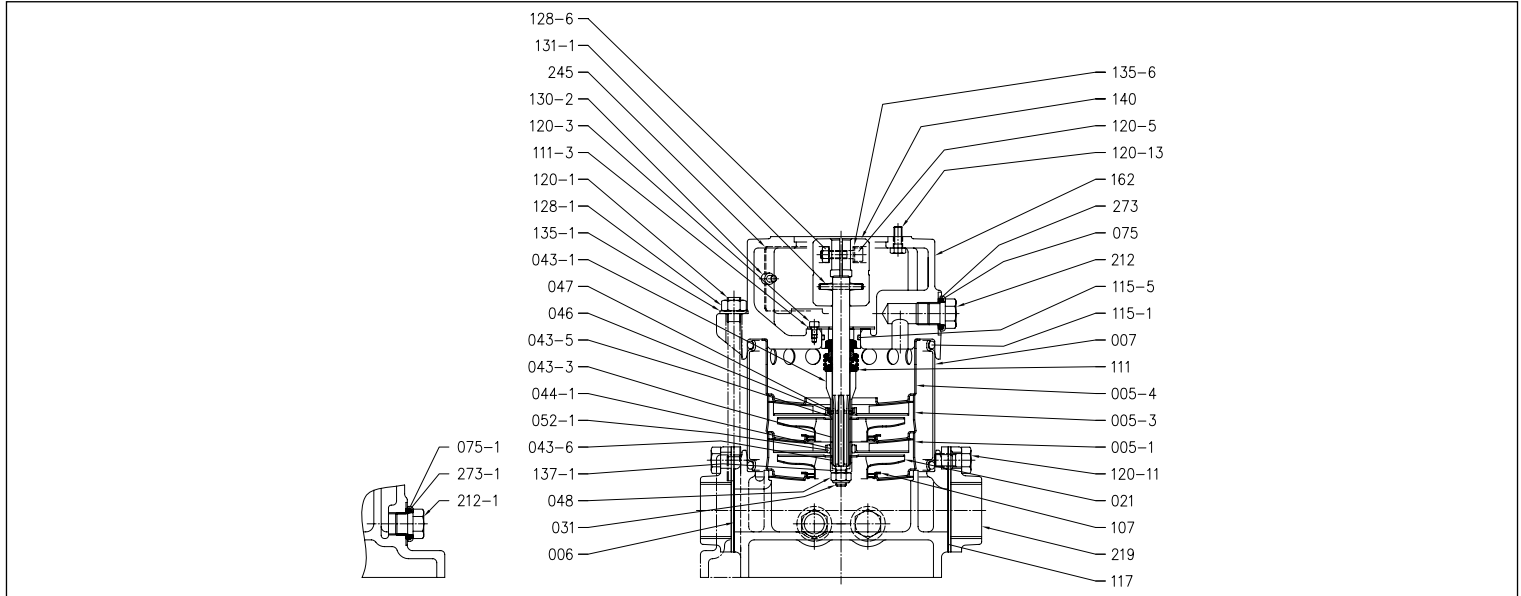

VISTA IN SEZIONE EVMG 3-18 Pump with single ball bearings

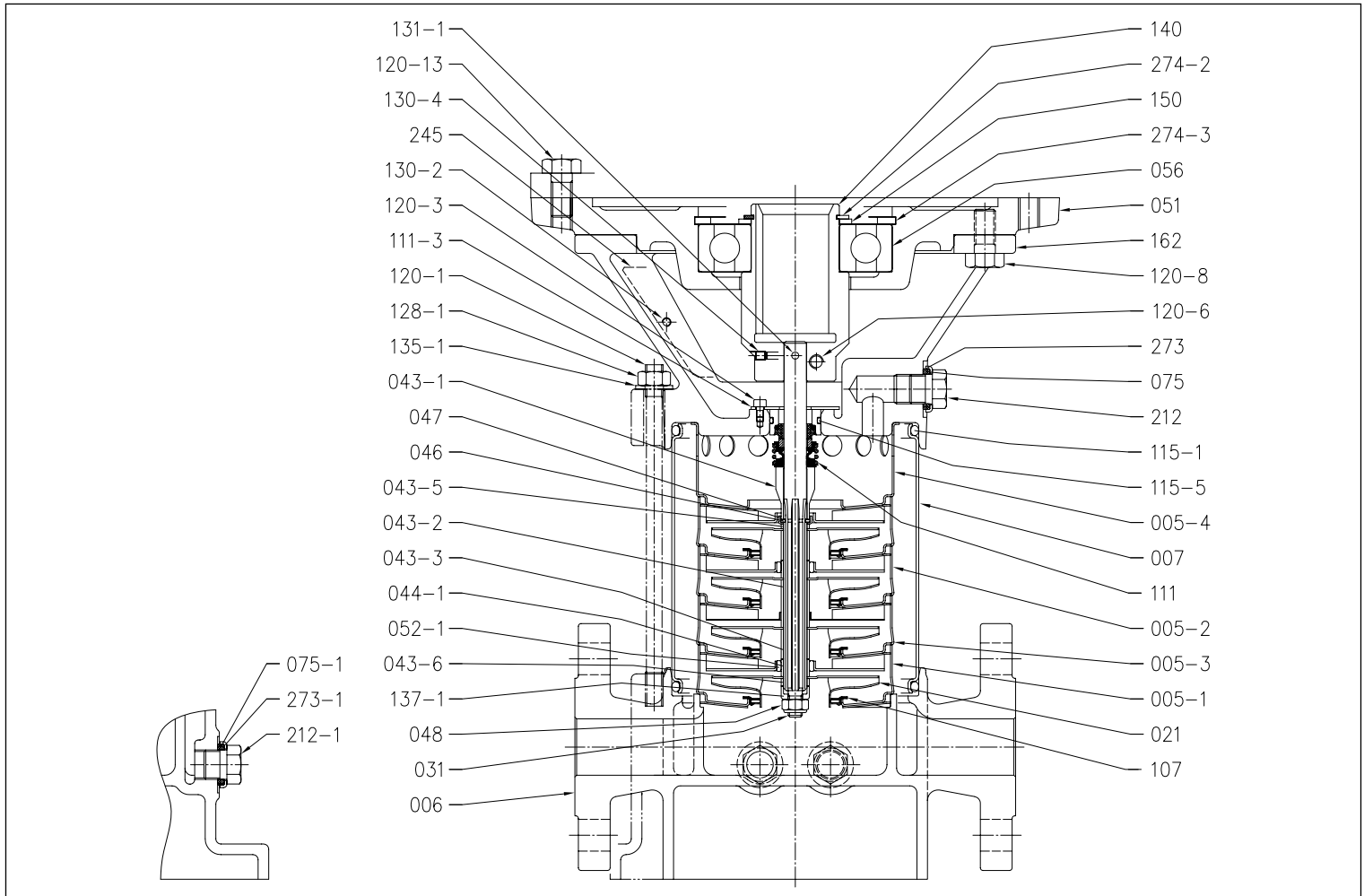

VERTICAL MULTISTAGE ELECTRIC PUMPS

in cast iron, AISI 304, AISI 316

TABELLA MATERIALI EVMG 3-18

Rif.	Nome	Materiale	Rif.	Nome	Materiale EVM
005-1	Suction stage	EN 1.4301(AISI 304)	075	O-Ring	EPDM
005-2	Intermediate stage	EN 1.4301(AISI 304)	107	Casing ring	PTFE/EN 1.4301(AISI 304)
005-3	Support stage kit	EN 1.4301(AISI 304)	111	Mechanical seal	SiC/Carbon/EPDM
005-4	Final stage	EN 1.4301(AISI 304)	115	O-Ring (external casing)	EPDM
006	Pump casing	Cast iron EN-GJL-200-EN 1561		O-Ring (stage)	-
007	External casing	EN 1.4301(AISI 304)		O-Ring (seal-holder flange)	EPDM
021	Impeller	EN 1.4301(AISI 304)	120-1	Joint screw	Galvanised steel 6.8 class ISO 898/1
031	Shaft	EN 1.4401 (AISI 316)	140	Joint	Die cast Aluminium EN AB-AISI11Cu2 (Fe) (up to 1.5kW) Brass OT 58 UNI 5705 (from 2.2kW and above)
044-1	Bearing	Tungsten Carbide	160	Pump body base	-
048	Impeller nut	A2-70 UNI 7323 (with stainless steel insert)	162	Motor bracket	Cast iron EN-GJL-200-EN 1561
051	Motor adapter	Cast iron EN-GJL-200-EN 1561	212	Plug	EN 1.4301(AISI 304)
052-1	Bearing	Tungsten Carbide	273	Washer	EN 1.4301(AISI 304)
056	Bearing	-			-

Commercial

VERTICAL MULTISTAGE ELECTRIC PUMPS

in cast iron, AISI 304, AISI 316

VISTA IN SEZIONE EVMG 32 Pump without bearings

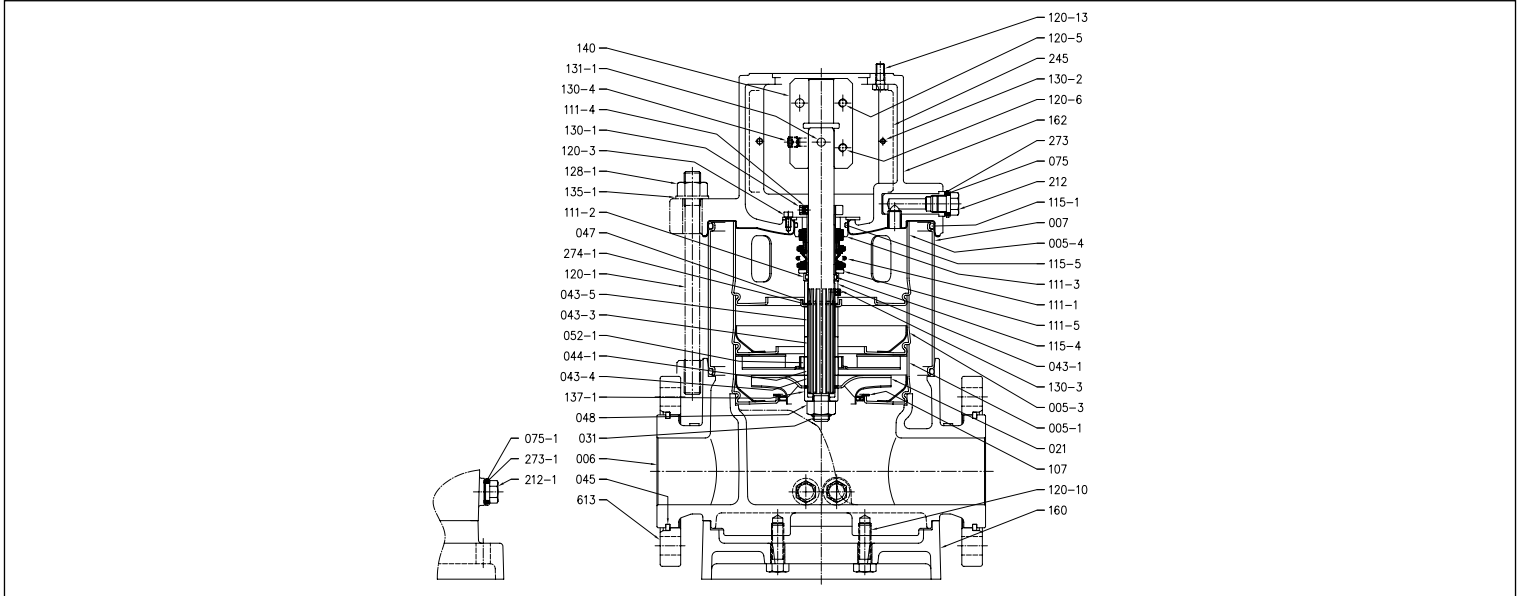

VISTA IN SEZIONE EVMG 32 Pump with single ball bearings

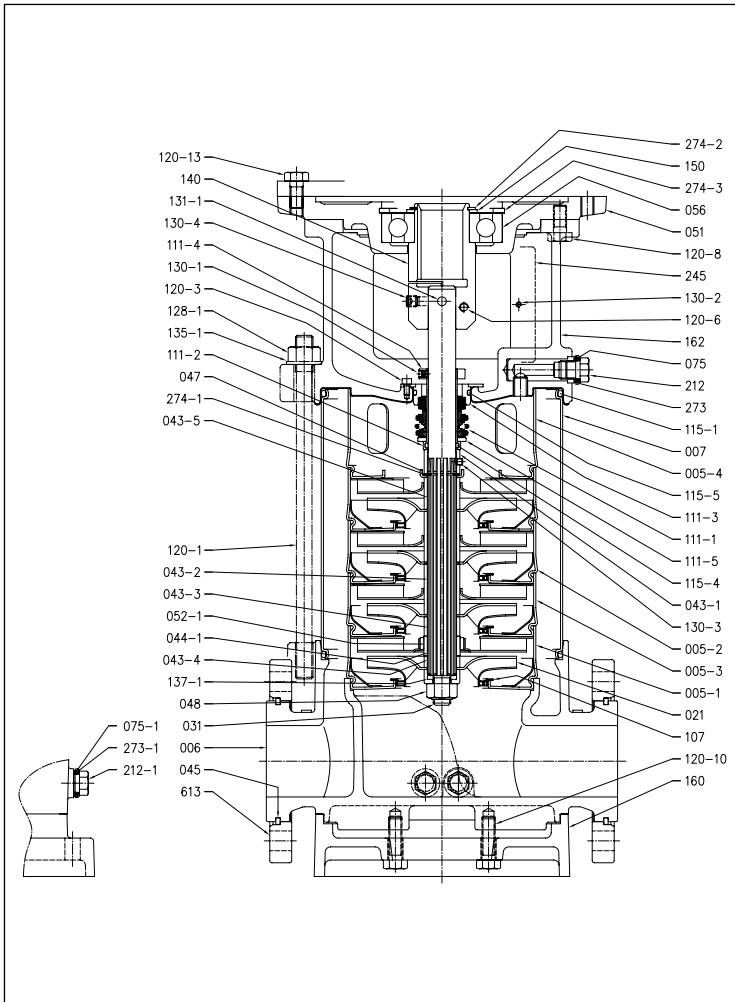

VISTA IN SEZIONE EVMG 32 Pump with double ball bearing

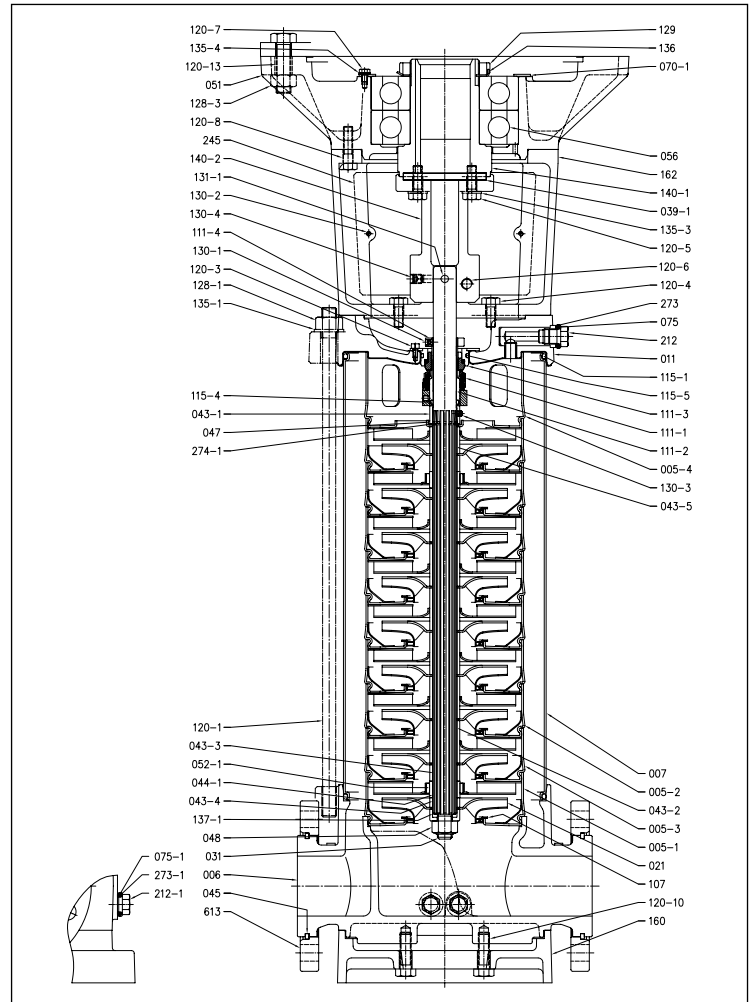

I contenuti della presente pubblicazione non devono essere considerati ingratificati. EBARA Pumps Europe Sp. A. si riserva il diritto di apportare senza preavviso le modifiche che riterrà più opportune.

VERTICAL MULTISTAGE ELECTRIC PUMPS

in cast iron, AISI 304, AISI 316

TABELLA MATERIALI EVMG 32

Rif.	Nome	Materiale	Rif.	Nome	Materiale EVM
005-1	Suction stage	EN 1.4301(AISI 304)	111-3	O-Ring	EN 1.4301(AISI 304)
005-3	Support stage kit	EN 1.4301(AISI 304)	111-4	Casing ring	Brass OT 58 UNI 5705
005-4	Final stage	EN 1.4301(AISI 304)	115	O-Ring (external casing)	EPDM
006	Pump casing	Cast iron EN-GJL-200-EN 1561		O-Ring (stage)	EPDM
007	External casing	EN 1.4301(AISI 304)		O-Ring (seal-holder flange)	EPDM
021	Impeller	EN 1.4301(AISI 304)	120-1	Joint screw	Galvanised steel 6.8 class ISO 898/1
031	Shaft	EN 1.4401 (AISI 316)	130-1	Screw	A2-70 UNI 7323
044-1	Bearing	Tungsten Carbide	140	Joint	Brass OT 58 UNI 5705
045	Flange half-ring	EN 1.402 (AISI 420)	140-1	Joint motor	Carbon
048	Impeller nut	A2-70 UNI 7323 (with stainless steel insert)	140-2	Joint	Carbon
052-1	Bearing	Tungsten Carbide	160	Pump body base	Cast iron EN-GJL-200-EN 1561
056	Bearing	-	162	Motor bracket	Cast iron EN-GJL-200-EN 1561
075	O-Ring	EPDM	212	Plug	EN 1.4301(AISI 304)
107	Casing ring	PTFE/EN 1.4301(AISI 304)	273	Washer	EN 1.4301(AISI 304)
111-1	Mechanical seal	SiC/Carbon/FPM	613	Flange	Carbon
111-2	Mechanical seal (cartridge)	EN 1.4301(AISI 304)			

Commercial

VERTICAL MULTISTAGE ELECTRIC PUMPS

in cast iron, AISI 304, AISI 316

VISTA IN SEZIONE EVMG 45-64 Pump without bearings

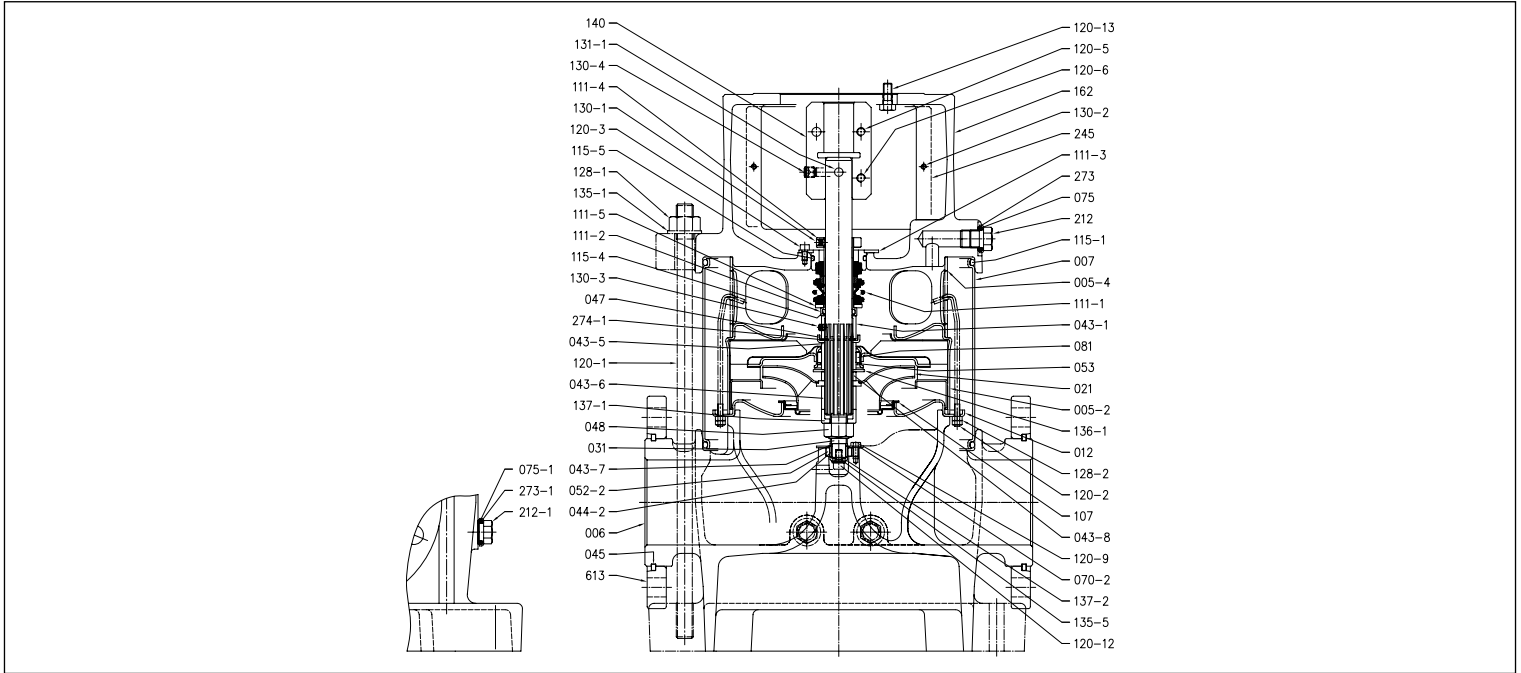

VISTA IN SEZIONE EVMG 45-64 Pump with single ball bearings

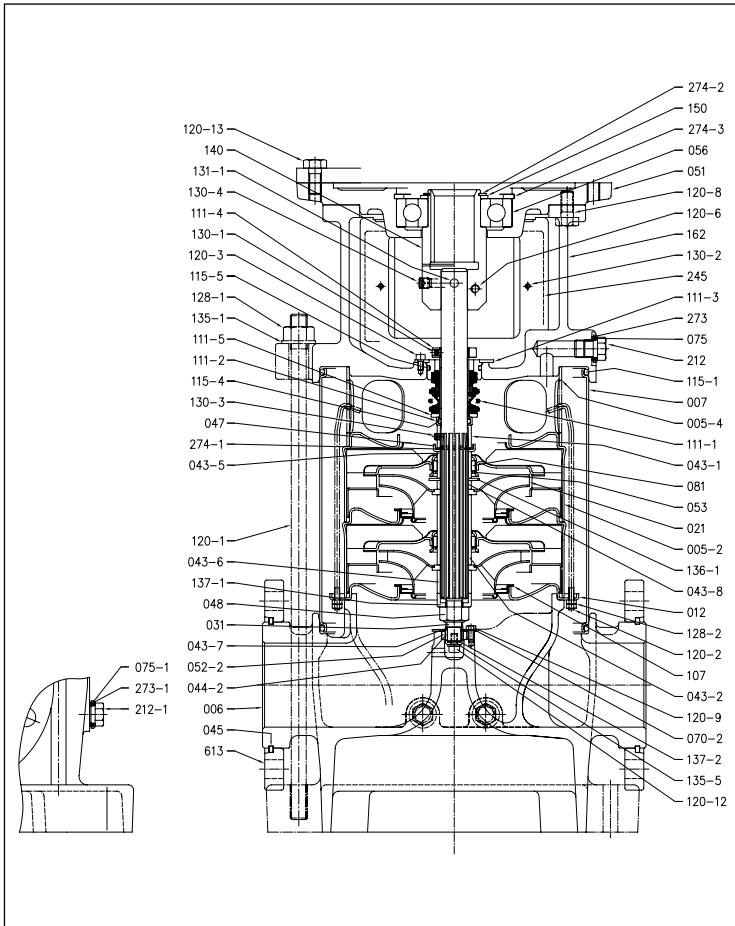

VISTA IN SEZIONE EVMG 45-64 Pump with double ball bearing

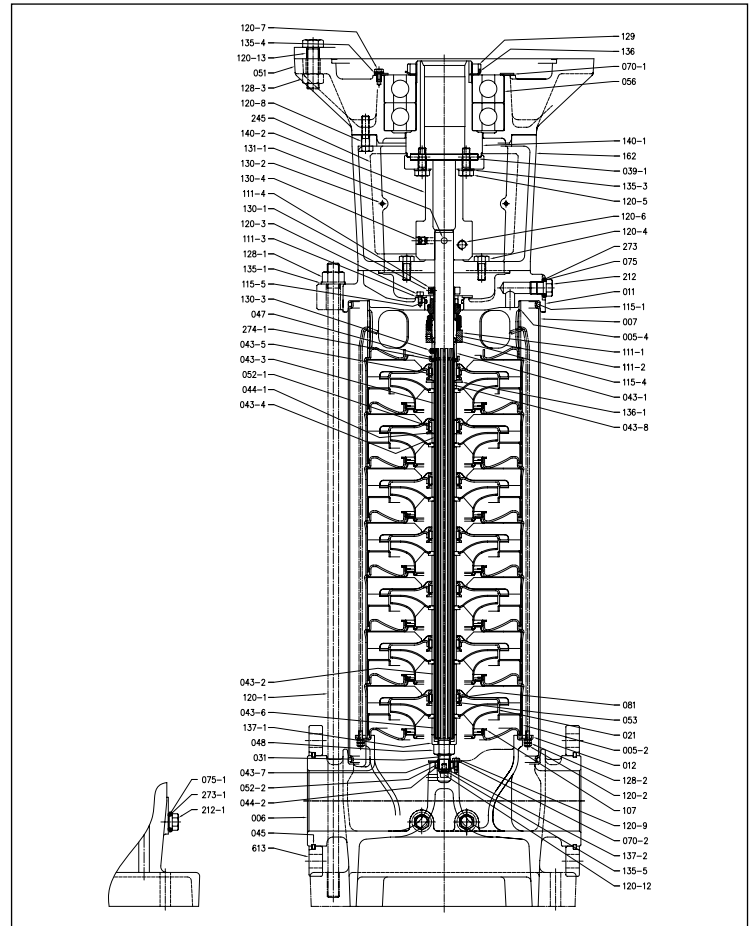

VERTICAL MULTISTAGE ELECTRIC PUMPS

in cast iron, AISI 304, AISI 316

TABELLA MATERIALI EVMG 45-64

Rif.	Nome	Materiale	Rif.	Nome	Materiale EVM
005-4	Final stage	EN 1.4301(AISI 304)	111-3	Mechanical seal seat	EN 1.4301(AISI 304)
006	Pump casing	Cast iron EN-GJL-200-EN 1561	111-4	Seal ring	Brass OT 58 UNI 5705
007	External casing	EN 1.4301(AISI 304)	115	O-Ring (external casing)	EPDM
012	Suction cover	EN 1.4301(AISI 304)		O-Ring (seal-holder flange)	EPDM
021	Impeller	EN 1.4301(AISI 304)		O-Ring (seal cover)	EPDM
031	Shaft	EN 1.4401 (AISI 316)	120-1	Joint screw	Galvanised steel 6.8 class ISO 898/1
044-1	Bearing	Tungsten Carbide	120-2	Tie-rod	EN 1.4301(AISI 304)
044-2	Bearing	Tungsten Carbide	128-2	Screw	Carbon
045	Flange half-ring	EN 1.402 (AISI 420)	130-1	Screw	A2-70 UNI 7323
048	Impeller nut	A2-70 UNI 7323 (with stainless steel insert)	140	Joint	Brass OT 58 UNI 5705
051	Motor adapter	Cast iron EN-GJL-200-EN 1561	140-1	Joint motor	Carbon
052-2	Bearing	Tungsten Carbide	140-2	Joint	Carbon
056	Bearing	-	160	Pump body base	-
075	O-Ring	EPDM	162	Motor bracket	Cast iron EN-GJL-200-EN 1561
081	Bush	PTFE	212	Plug	EN 1.4301(AISI 304)
107	Casing ring	PTFE/EN 1.4401 (AISI 316)	273	Washer	EN 1.4301(AISI 304)
111-1	Mechanical seal	SiC/Carbon/FPM	613	Flange	Carbon
111-2	Mechanical seal (cartridge)	EN 1.4301(AISI 304)			

MECHANICAL SEAL EVM 3-18



TABELLA MATERIALI

Rif.	Nome	Materiale
1	Fixed part	Carbon
2	Rotating part	SiC
3	Gasket	EPDM for EVM-EVMG FPM for EVML

MECHANICAL SEAL EVM 32-64

WITH CARTRIDGE up to 2.5 MPA

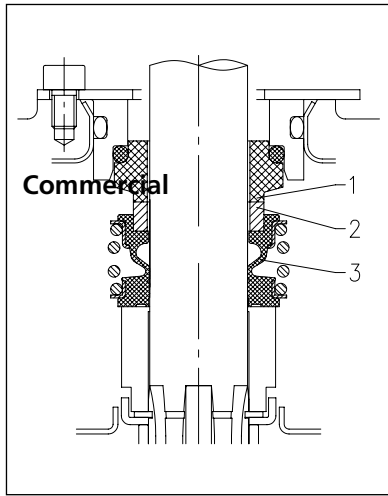

TABELLA MATERIALI

Rif.	Nome	Materiale
1	Fixed part	Carbon
2	Rotating part	SiC
3	Gasket	FPM

MECHANICAL SEAL EVM 32-64

SEALWITH CARTRIDGE from 2.5 to 3.0 MPA

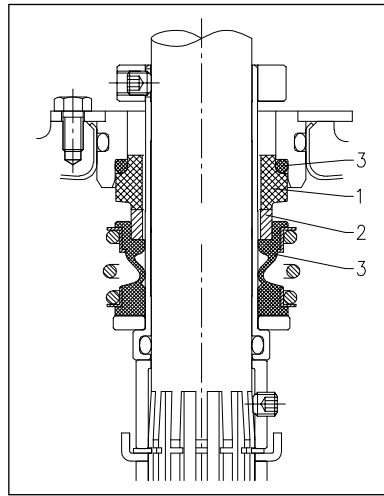

TABELLA MATERIALI

Rif.	Nome	Materiale
1	Parte fissa	Carbone
2	Parte rotante	SiC
3	Guarnizione	FPM

VERTICAL MULTISTAGE ELECTRIC PUMPS

in cast iron, AISI 304, AISI 316

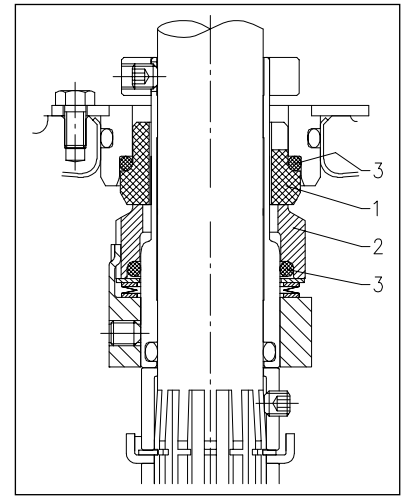
ELECTRIC DATA TABLE EVM 3-5

Model	Efficiency		Motor	Motor Power		Capacitor		Efficiency (%) and power factor						Absorbed Current [A]			
	Single phase	Three phase		[kW]	[HP]	Single-phase [μF]	Single-phase [V]	Single-phase η % 100%	Single-phase cos φ 100%	Three-phase			Single-phase 230V	Three-phase			
								50%	η % 75%	100%	cos φ 100%		230V	400V	690V		
EVM 3 2N5/0.37	-	-	71	0,37	0,5	16	400	57.6	0.89	58.0	64.0	70.0	0.78	3.1	1.7	1.0	-
EVM 3 3N5/0.37	-	-	71	0,37	0,5	16	400	57.6	0.89	58.0	64.0	70.0	0.78	3.1	1.7	1.0	-
EVM 3 4NEVM 5 0.55	-	-	71	0,55	0,75	16	400	69.0	0.89	57.0	64.0	71.0	0.77	3.9	2.6	1.5	-
EVM 3 5N5/0.55	-	-	71	0,55	0,75	16	400	69.0	0.89	57.0	64.0	71.0	0.77	3.9	2.6	1.5	-
EVM 3 6N5/0.75	-	IE2	80	0,75	1	25	400	65.0	0.95	77.3	78.5	80.5	0.78	5.3	2.9	1.7	-
	-	IE3				-	-	-	-	77.8	81.2	82.0	0.78	-	2.9	1.7	-
EVM 3 7N5/0.75	-	IE2	80	0,75	1	25	400	65.0	0.95	77.3	78.5	80.5	0.78	5.3	2.9	1.7	-
	-	IE3				-	-	-	-	77.8	81.2	82.0	0.78	-	2.9	1.7	-
EVM 3 9N5/1.1	-	IE2	80	1,1	1,5	36	400	74.0	0.97	79.5	81.2	81.5	0.78	6.5	4.3	2.5	-
	-	IE3				-	-	-	-	78.7	81.7	82.7	0.76	-	4.2	2.4	-
EVM 3 11N5/1.1	-	IE2	80	1,1	1,5	36	400	74.0	0.97	79.5	81.2	81.5	0.78	6.5	4.3	2.5	-
	-	IE3				-	-	-	-	78.7	81.7	82.7	0.76	-	4.2	2.4	-
EVM 3 13N5/1.5*	-	IE2	90S	1,5	2	35	400	79.0	0.97	81.0	82.8	82.8	0.80	8,8	5,5	3,2	-
	-	IE3				-	-	-	-	83.2	84.8	84.2	0.85	-	5,2	3,0	-
EVM 3 15N5/1.5*	-	IE2	90S	1,5	2	35	400	79.0	0.97	81.0	82.8	82.8	0.80	8,8	5,5	3,2	-
	-	IE3				-	-	-	-	83.2	84.8	84.2	0.85	-	5,2	3,0	-
EVM 3 18F5/2.2*	-	IE2	90L	2,2	3	40	400	78.0	0.97	82.5	84.0	84.0	0.85	12,9	7,6	4,4	-
	-	IE3				-	-	-	-	85.0	86.2	86.5	0.82	-	8,0	4,6	-
EVM 3 22F5/2.2*	-	IE2	90L	2,2	3	40	400	78.0	0.97	82.5	84.0	84.0	0.85	12,9	7,6	4,4	-
	-	IE3				-	-	-	-	85.0	86.2	86.5	0.82	-	8,0	4,6	-
EVM 3 26F5/3.0	-	IE2	100L	3	4	-	-	-	-	84.1	85.8	85.5	0.84	-	10,2	5,9	-
	-	IE3				-	-	-	-	82.3	85.8	87.1	0.89	-	9,7	5,6	-
EVM 5 2N5/0.37	-	-	71	0,37	0,5	16	400	57.6	0.89	58.0	64.0	70.0	0.78	3.1	1.7	1.0	-
EVM 5 3N5/0.55	-	-	71	0,55	0,75	16	400	69.0	0.89	57.0	64.0	71.0	0.77	3.9	2.6	1.5	-
EVM 5 4N5/0.75	-	IE2	80	0,75	1	25	400	65.0	0.95	77.3	78.5	80.5	0.78	5.3	2.9	1.7	-
	-	IE3				-	-	-	-	77.8	81.2	82.0	0.78	-	2.9	1.7	-
EVM 5 5N5/1.1	-	IE2	80	1,1	1,5	36	400	74.0	0.97	79.5	81.2	81.5	0.78	6.5	4.3	2.5	-
	-	IE3				-	-	-	-	78.7	81.7	82.7	0.76	-	4.2	2.4	-
EVM 5 6N5/1.1	-	IE2	80	1,1	1,5	36	400	74.0	0.97	79.5	81.2	81.5	0.78	6.5	4.3	2.5	-
	-	IE3				-	-	-	-	78.7	81.7	82.7	0.76	-	4.2	2.4	-
EVM 5 7N5/1.5*	-	IE2	90S	1,5	2	35	400	79.0	0.97	81.0	82.8	82.8	0.80	8,8	5,5	3,2	-
	-	IE3				-	-	-	-	83.2	84.8	84.2	0.85	-	5,2	3,0	-
EVM 5 8N5/1.5*	-	IE2	90S	1,5	2	35	400	79.0	0.97	81.0	82.8	82.8	0.80	8,8	5,5	3,2	-
	-	IE3				-	-	-	-	83.2	84.8	84.2	0.85	-	5,2	3,0	-
EVM 5 10N5/2.2*	-	IE2	90L	2,2	3	40	400	78.0	0.97	82.5	84.0	84.0	0.85	12,9	7,6	4,4	-
	-	IE3				-	-	-	-	85.0	86.2	86.5	0.82	-	8,0	4,6	-
EVM 5 11N5/2.2*	-	IE2	90L	2,2	3	40	400	78.0	0.97	82.5	84.0	84.0	0.85	12,9	7,6	4,4	-
	-	IE3				-	-	-	-	85.0	86.2	86.5	0.82	-	8,0	4,6	-
EVM 5 12N5/2.2*	-	IE2	90L	2,2	3	40	400	78.0	0.97	82.5	84.0	84.0	0.85	12,9	7,6	4,4	-
	-	IE3				-	-	-	-	85.0	86.2	86.5	0.82	-	8,0	4,6	-
EVM 5 14N5/3.0	-	IE2	100L	3	4	-	-	-	-	84.1	85.8	85.5	0.84	-	10,2	5,9	-
	-	IE3				-	-	-	-	82.3	85.8	87.1	0.89	-	9,7	5,6	-
EVM 5 16N5/3.0	-	IE2	100L	3	4	-	-	-	-	84.1	85.8	85.5	0.84	-	10,2	5,9	-
	-	IE3				-	-	-	-	82.3	85.8	87.1	0.89	-	9,7	5,6	-
EVM 5 18F5/4.0	-	IE2	112M	4	5,5	-	-	-	-	85.2	86.4	86.1	0.86	-	13,5	7,8	-
	-	IE3				-	-	-	-	86.8	87.8	88.1	0.93	-	12,1	7,0	-
EVM 5 19F5/4.0	-	IE2	112M	4	5,5	-	-	-	-	85.2	86.4	86.1	0.86	-	13,5	7,8	-
	-	IE3				-	-	-	-	86.8	87.8	88.1	0.93	-	12,1	7,0	-
EVM 5 22F5/4.0	-	IE2	112M	4	5,5	-	-	-	-	85.2	86.4	86.1	0.86	-	13,5	7,8	-
	-	IE3				-	-	-	-	86.8	87.8	88.1	0.93	-	12,1	7,0	-
EVM 5 24F5/5.5	-	IE2	132S	5,5	7,5	-	-	-	-	85.8	87.4	87.3	0.88	-	-	10,4	6,0
	-	IE3				-	-	-	-	88.0	88.5	89.2	0.90	-	-	10,0	5,8

*= Single phase motors manufactured by Ebara

VERTICAL MULTISTAGE ELECTRIC PUMPS

in cast iron, AISI 304, AISI 316

ELECTRIC DATA TABLE EVM 10-18

Model	Efficiency		Motor	Motor Power		Capacitor		Efficiency (%) and power factor						Absorbed Current [A]			
	Single-phase	Three-phase		[kW]	[HP]	Single-phase [μF]	Single-phase [V]	Single-phase η % 100%	Single-phase cos φ 100%	Three-phase			Single-phase 230V	Three-phase			
								50%	η % 75%	100%	cos φ 100%		230V	400V	690V		
EVM 10 2N5/0.75	-	IE2	80	0,75	1	25	400	65.0	0.95	77.3	78.5	80.5	0.78	5.3	2.9	1.7	-
	-	IE3				-	-	-	-	-	-	77.8	81.2	82.0	0.78	-	2.9
EVM 10 3N5/1.1	-	IE2	80	1,1	1,5	36	400	74.0	0.97	79.5	81.2	81.5	0.78	6.5	4.3	2.5	-
	-	IE3				-	-	-	-	-	-	78.7	81.7	82.7	0.76	-	4.2
EVM 10 4N5/1.5*	-	IE2	90S	1,5	2	35	400	79.0	0.97	81.0	82.8	82.8	0.80	8,8	5.5	3.2	-
	-	IE3				-	-	-	-	-	-	83.2	84.8	84.2	0.85	-	5.2
EVM 10 5N5/2.2*	-	IE2	90L	2,2	3	40	400	78.0	0.97	82.5	84.0	84.0	0.85	12,9	7.6	4.4	-
	-	IE3				-	-	-	-	-	-	85.0	86.2	86.5	0.82	-	8.0
EVM 10 6N5/2.2*	-	IE2	90L	2,2	3	40	400	78.0	0.97	82.5	84.0	84.0	0.85	12,9	7.6	4.4	-
	-	IE3				-	-	-	-	-	-	85.0	86.2	86.5	0.82	-	8.0
EVM 10 8N5/3.0	-	IE2	100L	3	4	-	-	-	-	84.1	85.8	85.5	0.84	-	10.2	5.9	-
	-	IE3				-	-	-	-	-	-	82.3	85.8	87.1	0.89	-	9.7
EVM 10 10N5/4.0	-	IE2	112M	4	5,5	-	-	-	-	85.2	86.4	86.1	0.86	-	13.5	7.8	-
	-	IE3				-	-	-	-	-	-	86.8	87.8	88.1	0.93	-	12.1
EVM 10 11N5/4.0	-	IE2	112M	4	5,5	-	-	-	-	85.2	86.4	86.1	0.86	-	13.5	7.8	-
	-	IE3				-	-	-	-	-	-	86.8	87.8	88.1	0.93	-	12.1
EVM 10 12N5/5.5	-	IE2	132S	5,5	7,5	-	-	-	-	85.8	87.4	87.3	0.88	-	-	10.4	6.0
	-	IE3				-	-	-	-	-	-	88.0	88.5	89.2	0.90	-	-
EVM 10 14N5/5.5	-	IE2	132S	5,5	7,5	-	-	-	-	85.8	87.4	87.3	0.88	-	-	10.4	6.0
	-	IE3				-	-	-	-	-	-	88.0	88.5	89.2	0.90	-	-
EVM 10 15F5/5.5	-	IE2	132S	5,5	7,5	-	-	-	-	85.8	87.4	87.3	0.88	-	-	10.4	6.0
	-	IE3				-	-	-	-	-	-	88.0	88.5	89.2	0.90	-	-
EVM 10 16F5/7.5	-	IE3	132S	7,5	1,0	-	-	-	-	88.6	89.2	90.1	0.92	-	-	13.1	7.6
EVM 10 18F5/7.5	-	IE3	132S	7,5	1,0	-	-	-	-	88.6	89.2	90.1	0.92	-	-	13.1	7.6
EVM 10 20F5/7.5	-	IE3	132S	7,5	1,0	-	-	-	-	88.6	89.2	90.1	0.92	-	-	13.1	7.6
EVM 10 22F5/11	-	IE3	160M	1,1	1,5	-	-	-	-	87.4	89.8	91.2	0.89	-	-	19.7	11.4
EVM 18 2F5/2.2* Commercial	-	IE2	90L	2,2	3	40	400	78.0	0.97	82.5	84.0	84.0	0.85	12,9	7.6	4.4	-
	-	IE3				-	-	-	-	-	-	85.0	86.2	86.5	0.82	-	8.0
EVM 18 3F5/3.0	-	IE2	100L	3	4	-	-	-	-	84.1	85.8	85.5	0.84	-	10.2	5.9	-
	-	IE3				-	-	-	-	-	-	82.3	85.8	87.1	0.89	-	9.7
EVM 18 4F5/4.0	-	IE2	112M	4	5,5	-	-	-	-	85.2	86.4	86.1	0.86	-	13.5	7.8	-
	-	IE3				-	-	-	-	-	-	86.8	87.8	88.1	0.93	-	12.1
EVM 18 5F5/5.5	-	IE2	132S	5,5	7,5	-	-	-	-	85.8	87.4	87.3	0.88	-	-	10.4	6.0
	-	IE3				-	-	-	-	-	-	88.0	88.5	89.2	0.90	-	-
EVM 18 6F5/5.5	-	IE2	132S	5,5	7,5	-	-	-	-	85.8	87.4	87.3	0.88	-	-	10.4	6.0
	-	IE3				-	-	-	-	-	-	88.0	88.5	89.2	0.90	-	-
EVM 18 7F5/7.5	-	IE3	132S	7,5	1,0	-	-	-	-	88.6	89.2	90.1	0.92	-	-	13.1	7.6
EVM 18 8F5/7.5	-	IE3	132S	7,5	1,0	-	-	-	-	88.6	89.2	90.1	0.92	-	-	13.1	7.6
EVM 18 10F5/11	-	IE3	160M	1,1	1,5	-	-	-	-	87.4	89.8	91.2	0.89	-	-	19.7	11.4
EVM 18 12F5/11	-	IE3	160M	1,1	1,5	-	-	-	-	87.4	89.8	91.2	0.89	-	-	19.7	11.4
EVM 18 14F5/15	-	IE3	160M	1,5	2,0	-	-	-	-	91.0	91.3	91.9	0.89	-	-	26.7	15.4
EVM 18 15F5/15	-	IE3	160M	1,5	2,0	-	-	-	-	91.0	91.3	91.9	0.89	-	-	26.7	15.4
EVM 18 16F5/15	-	IE3	160M	1,5	2,0	-	-	-	-	91.0	91.3	91.9	0.89	-	-	26.7	15.4

VERTICAL MULTISTAGE ELECTRIC PUMPS

in cast iron, AISI 304, AISI 316

ELECTRIC DATA TABLE EVM 32-45

Model	Efficiency	Motor	Motor Power		Efficiency (%) and power factor				Absorbed Current [A]		
			[kW]	[HP]	50%	75%	100%	cos ϕ 100%	230V	400V	690V
EVM 32 1-0F5/2.2	IE2	90L	22	3	82.5	84.0	84.0	0.85	7.6	4.4	-
	IE3				85.0	86.2	86.5	0.82	8.0	4.6	-
EVM 32 2-2F5/3.0	IE2	100L	3	4	84.1	85.8	85.5	0.84	10.2	5.9	-
	IE3				82.3	85.8	87.1	0.89	9.7	5.6	-
EVM 32 2-0F5/4.0	IE2	112M	4	55	85.2	86.4	86.1	0.86	13.5	7.8	-
	IE3				86.8	87.8	88.1	0.93	12.1	7.0	-
EVM 32 3-3F5/5.5	IE2	132S	55	75	85.8	87.4	87.3	0.88	-	10.4	6.0
	IE3				88.0	88.5	89.2	0.90	-	10.0	5.8
EVM 32 3-1F5/5.5	IE2	132S	55	75	85.8	87.4	87.3	0.88	-	10.4	6.0
	IE3				88.0	88.5	89.2	0.90	-	10.0	5.8
EVM 32 4-3F5/7.5	IE3	132S	75	10	88.6	89.2	90.1	0.92	-	13.1	7.6
EVM 32 4-1F5/7.5	IE3	132S	75	10	88.6	89.2	90.1	0.92	-	13.1	7.6
EVM 32 5-3F5/11	IE3	160M	11	15	87.4	89.8	91.2	0.89	-	19.7	11.4
EVM 32 5-0F5/11	IE3	160M	11	15	87.4	89.8	91.2	0.89	-	19.7	11.4
EVM 32 6-3F5/11	IE3	160M	11	15	87.4	89.8	91.2	0.89	-	19.7	11.4
EVM 32 6-2F5/11	IE3	160M	11	15	87.4	89.8	91.2	0.89	-	19.7	11.4
EVM 32 7-3F5/15	IE3	160M	15	20	91.0	91.3	91.9	0.89	-	26.7	15.4
EVM 32 7-0F5/15	IE3	160M	15	20	91.0	91.3	91.9	0.89	-	26.7	15.4
EVM 32 8-3F5/15	IE3	160M	15	20	91.0	91.3	91.9	0.89	-	26.7	15.4
EVM 32 8-2F5/15	IE3	160M	15	20	91.0	91.3	91.9	0.89	-	26.7	15.4
EVM 32 9-3F5/18.5	IE3	160L	185	25	91.6	92.8	92.4	0.88	-	33.0	19.1
EVM 32 9-0F5/18.5	IE3	160L	185	25	91.6	92.8	92.4	0.88	-	33.0	19.1
EVM 32 10-3F5/18.5	IE3	160L	185	25	91.6	92.8	92.4	0.88	-	33.0	19.1
EVM 32 10-2F5/18.5	IE3	160L	185	25	91.6	92.8	92.4	0.88	-	33.0	19.1
EVM 32 11-3F5/22	IE3	180M	22	30	92.3	92.9	92.9	0.90	-	38.0	22.0
EVM 32 11-0F5/22	IE3	180M	22	30	92.3	92.9	92.9	0.90	-	38.0	22.0
EVM 32 12-3F5/22	IE3	180M	22	30	92.3	92.9	92.9	0.90	-	38.0	22.0
EVM 32 13-3F5/30	IE3	200L	30	40	92.8	93.9	94.0	0.89	-	51.8	30.0
EVM 32 13-0F5/30	IE3	200L	30	40	92.8	93.9	94.0	0.89	-	51.8	30.0
EVM 32 14-3F5/30	IE3	200L	30	40	92.8	93.9	94.0	0.89	-	51.8	30.0
EVM 32 14-0F5/30	IE3	200L	30	40	92.8	93.9	94.0	0.89	-	51.8	30.0
EVM 45 1-1F5/3.0	IE2	100L	3	4	84.1	85.8	85.5	0.84	10.2	5.9	-
	IE3				82.3	85.8	87.1	0.89	9.7	5.6	-
EVM 45 1-0F5/4.0	IE2	112M	4	55	85.2	86.4	86.1	0.86	13.5	7.8	-
	IE3				86.8	87.8	88.1	0.93	12.1	7.0	-
EVM 45 2-2F5/5.5	IE2	132S	55	75	85.8	87.4	87.3	0.88	-	10.4	6.0
	IE3				88.0	88.5	89.2	0.90	-	10.0	5.8
EVM 45 2-0F5/7.5	IE3	132S	75	10	88.6	89.2	90.1	0.92	-	13.1	7.6
EVM 45 3-2F5/11	IE3	160M	11	15	87.4	89.8	91.2	0.89	-	19.7	11.4
EVM 45 3-0F5/11	IE3	160M	11	15	87.4	89.8	91.2	0.89	-	19.7	11.4
EVM 45 4-2F5/15	IE3	160M	15	20	91.0	91.3	91.9	0.89	-	26.7	15.4
EVM 45 4-0F5/15	IE3	160M	15	20	91.0	91.3	91.9	0.89	-	26.7	15.4
EVM 45 5-2F5/18.5	IE3	160L	185	25	91.6	92.8	92.4	0.88	-	33.0	19.1
EVM 45 5-0F5/18.5	IE3	160L	185	25	91.6	92.8	92.4	0.88	-	33.0	19.1
EVM 45 6-2F5/22	IE3	180M	22	30	92.3	92.9	92.9	0.90	-	38.0	22.0
EVM 45 6-0F5/22	IE3	180M	22	30	92.3	92.9	92.9	0.90	-	38.0	22.0
EVM 45 7-2F5/30	IE3	200L	30	40	92.8	93.9	94.0	0.89	-	51.8	30.0
EVM 45 7-0F5/30	IE3	200L	30	40	92.8	93.9	94.0	0.89	-	51.8	30.0
EVM 45 8-2F5/30	IE3	200L	30	40	92.8	93.9	94.0	0.89	-	51.8	30.0
EVM 45 8-0F5/30	IE3	200L	30	40	92.8	93.9	94.0	0.89	-	51.8	30.0
EVM 45 9-2F5/30	IE3	200L	30	40	92.8	93.9	94.0	0.89	-	51.8	30.0
EVM 45 9-0F5/37	IE3	200L	37	50	93.0	93.9	93.8	0.90	-	62.5	36.0
EVM 45 10-2F5/37	IE3	200L	37	50	93.0	93.9	93.8	0.90	-	62.5	36.0
EVM 45 10-0F5/37	IE3	200L	37	50	93.0	93.9	93.8	0.90	-	62.5	36.0

I contenuti della presente pubblicazione non devono essere considerati ingratificativi. EBARA Pumps Europe Sp. A. si riserva il diritto di apportare senza preavviso le modifiche che riterrà più opportune.

VERTICAL MULTISTAGE ELECTRIC PUMPS

in cast iron, AISI 304, AISI 316

ELECTRIC DATA TABLE EVM 64

Model	Efficiency	Motor	Motor Power		Efficiency (%) and power factor				Absorbed Current [A]		
			[kW]	[HP]	50%	η % 75%	100%	cos ϕ 100%	230V	400V	690V
64 1-1F5/4.0	IE2	112M	4	55	85.2	86.4	86.1	0.86	13.5	7.8	-
	IE3				86.8	87.8	88.1	0.93	12.1	7.0	-
64 1-0F5/5.5	IE2	132S	55	75	85.8	87.4	87.3	0.88	-	10.4	6.0
	IE3				88.0	88.5	89.2	0.90	-	10.0	5.8
64 2-2F5/7.5	IE3	132S	75	10	88.6	89.2	90.1	0.92	-	13.1	7.6
64 2-1F5/11	IE3	160M	11	15	87.4	89.8	91.2	0.89	-	19.7	11.4
64 2-0F5/11	IE3	160M	11	15	87.4	89.8	91.2	0.89	-	19.7	11.4
64 3-3F5/15	IE3	160M	15	20	91.0	91.3	91.9	0.89	-	26.7	15.4
64 3-2F5/15	IE3	160M	15	20	91.0	91.3	91.9	0.89	-	26.7	15.4
64 3-1F5/15	IE3	160M	15	20	91.0	91.3	91.9	0.89	-	26.7	15.4
64 3-0F5/18.5	IE3	160L	185	25	91.6	92.8	92.4	0.88	-	33.0	19.1
64 4-3F5/18.5	IE3	160L	185	25	91.6	92.8	92.4	0.88	-	33.0	19.1
64 4-2F5/18.5	IE3	160L	185	25	91.6	92.8	92.4	0.88	-	33.0	19.1
64 4-1F5/22	IE3	180M	22	30	92.3	92.9	92.9	0.90	-	38.0	22.0
64 4-0F5/22	IE3	180M	22	30	92.3	92.9	92.9	0.90	-	38.0	22.0
64 5-3F5/30	IE3	200L	30	40	92.8	93.9	94.0	0.89	-	51.8	30.0
64 5-2F5/30	IE3	200L	30	40	92.8	93.9	94.0	0.89	-	51.8	30.0
64 5-1F5/30	IE3	200L	30	40	92.8	93.9	94.0	0.89	-	51.8	30.0
64 5-0F5/30	IE3	200L	30	40	92.8	93.9	94.0	0.89	-	51.8	30.0
64 6-3F5/30	IE3	200L	30	40	92.8	93.9	94.0	0.89	-	51.8	30.0
64 6-2F5/30	IE3	200L	30	40	92.8	93.9	94.0	0.89	-	51.8	30.0
64 6-1F5/37	IE3	200L	37	50	93.0	93.9	93.8	0.90	-	62.5	36.0
64 6-0F5/37	IE3	200L	37	50	93.0	93.9	93.8	0.90	-	62.5	36.0
64 7-3F5/37	IE3	200L	37	50	93.0	93.9	93.8	0.90	-	62.5	36.0
64 7-2F5/37	IE3	200L	37	50	93.0	93.9	93.8	0.90	-	62.5	36.0
64 7-1F5/37	IE3	200L	37	50	93.0	93.9	93.8	0.90	-	62.5	36.0

Commercial

