



Japanese Technology since 1912

EVM series - Vertical Multistage Pumps

Data Book 50Hz



EVMS 1-3-5-10-15-20
EVM 32-45-64



EVMS

EVM

	Page
1. SPECIFICATIONS ^①	
1.1 TYPICAL APPLICATIONS	101
1.2 PERFORMANCE RANGE	102
2. EVMS 1-3-5-10-15-20	200
2.1 PRODUCT FEATURES	201
2.2 PRODUCT SPECIFICATIONS	202
2.3 SHAFT SEAL	203
2.4 TYPE KEY and NAMEPLATE	204
2.5 PERFORMANCE RANGE	205
2.6 CURVE SPECIFICATIONS	206
2.7 SELECTION CHART	207
2.8 EVMS(L)1	209
EVMSG1	215
2.9 EVMS(L)3	221
EVMSG3	227
2.10 EVMS(L)5	233
EVMSG5	239
2.11 EVMS(L)10	245
EVMSG10	251
2.12 EVMS(L)15	257
EVMSG15	263
2.13 EVMS(L)20	269
EVMSG20	275
2.14 PACKING	281
3. EVM 32-45-64	300
3.1 PRODUCT FEATURES	301
3.2 PRODUCT SPECIFICATIONS	302
3.3 SHAFT SEAL	303
3.4 TYPE KEY and NAMEPLATE	304
3.5 PERFORMANCE RANGE	305
3.6 CURVE SPECIFICATIONS	306
3.7 SELECTION CHART	307
3.8 EVM(L)32	308
EVMG32	323
3.9 EVM(L)45	338
EVMG45	351
3.10 EVM(L)64	364
EVMG64	379
3.11 PACKING	394
4. MOTOR DATA	400
4.1 NOISE DATA	401
4.2 TECHNICAL MOTOR DATA	402
EVMS 1-3-5-10-15-20	402
EVM 32-45-64	403

Rev.B

① click INDEX to jump CORRESPONDING SECTION



② click  to go back to INDEX

VERTICAL MULTISTAGE PUMPS

TYPICAL APPLICATIONS

1.1

TYPICAL APPLICATIONS

INDUSTRY	BUILDING SERVICE	WATER SUPPLY
		
<ul style="list-style-type: none"> • Water treatment reverse osmosis ultra-filtration water purification micro-filtration softening, ionizing and demineralising systems swimming pools separators • Boiler feeding steam systems condensate systems • Wash and clean vehicle washing systems industrial part washing laundry systems supply of liquids with acids and bases supply of chemical liquids • Chilling handling of refrigerants for cooling thermal control systems industrial cooling laser cooling • Machine tooling cooling lubricant supply for tooling machines • Pressure boosting pressure boosting for industrial use • Food & beverage food washing systems bottle wash systems • Pharmaceutical industries • Marine applications freshwater, deckwash, high fog and fire fighting on ships 	<ul style="list-style-type: none"> • Pressure boosting pressure boosting for buildings pressure boosting for high rise buildings/hotels • Sprinkler systems • Fire fighting systems jockey pump • District heating • Heat exchangers / fan heaters • Air conditioning systems • Heating systems 	<ul style="list-style-type: none"> • Water treatment water treatment plants filtration water treatment plants transfer • Pressure boosting transfer from water treatment plants (mains) • Irrigation golf course / sport fields irrigation • Agriculture sprinkler irrigation drip irrigation

VERTICAL MULTISTAGE PUMPS

PERFORMANCE RANGE

PERFORMANCE RANGE
EVMS(.)1-3-5-10-15-20
EVM(.)32-45-64

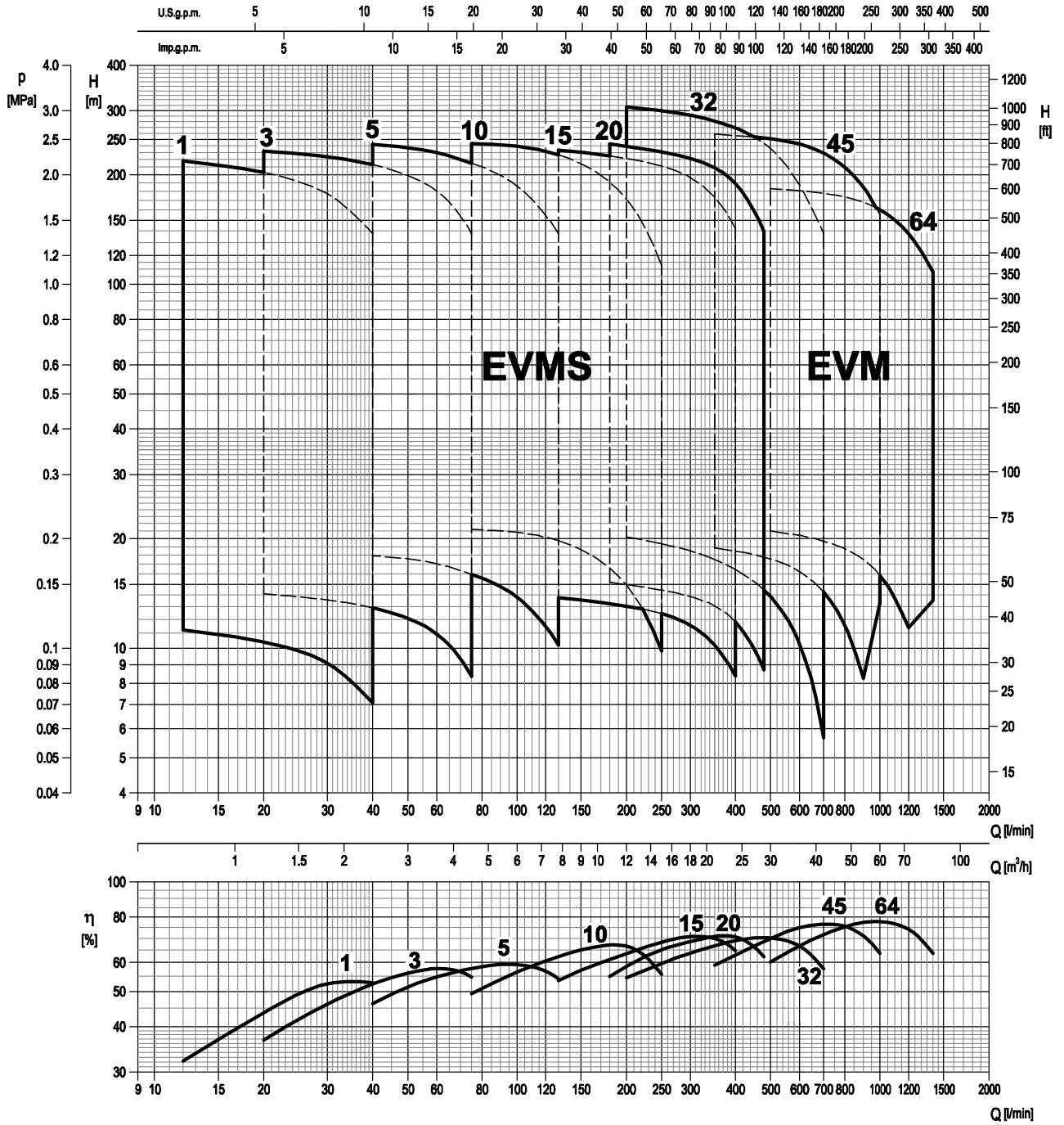

EVMS

PRODUCT FEATURES

[General]

1. Pump Type

The EVMS is Non-self-priming, vertical multistage in line, centrifugal pumps.

2. Model range

The EVMS comes in **1,3,5,10,15 and 20 m³/h flow sizes** for the majority market needs.

3. Maximum operating pressure

The EVMS can be operated at **16 bar or 25 bar as maximum**.

4. Operating temperature range

The EVMS can be operated **from - 30 to + 140 °C** as the maximum.

5. Material options

AISI 304, AISI 316 and Cast iron versions are available.



6. Motor

The EVMS can be coupled with **the commercial motors** that are acquired in the markets.

The EVMS can be provided as the electric pump with IE3 motor for the over 0.75 kW.

PTC sensor is available from 1.5 kW motor.

7. Certifications

	DM174/2004  TIFQ prodotto conforme D.M.174/2004	ACS  ATTENZIONE DE CONFORMITE SANITARE ACS	KTW [*]  CERTIFIED COMPONENTS
Drinking water approval			
<u>Mechanical seal</u>	SiC/Carbon_EPDM	SiC/Carbon_EPDM	SiC with graphite/SiC_EPDM
EVMSG	•	-	-
EVMS	•	•	○
EVMSL	•	•	○

Note: * KTW is certified for components.

• Standard
○ On request

8. Conform to the provisions of the European directives



[Main Product Features]

1. Innovative hydraulic solutions

- **Commercial motors** can be fitted to all of the pump models without any modifications thanks to low pump axial thrust load.
- Low axial thrust load impeller can ensure **long life of the motor bearing**.
- **High pump efficiency** classified in MEI > 0.7 for all models.

2. Energy saving

- **High efficiency IE3 motor** starting from 0.75 kW complied with the EuP 2005/32/EC and ErP 2009/125/EC directives.
- The **VFD (Variable frequency drive)** and the **commercial sensor** can be directly mounted on EVMS to **maintain physical constant operations** such as pumping pressure depending on the conditions of use.

3. Piping connection options

- The various pipe connections are available depending on the application requirements **Oval flange / Round flange / Loose flange / Victaulic® / Clamp**
- The external dimensions can be adjusted to the replacement of the existing pump in the wide majority

4. Shaft seal solutions

- Silicon carbide inclusions with graphite can be used as **dry lubricant to reduce friction**.
- It's conforming to EN12756 (ex DIN 24960)

5. Easy maintenance

- The **cartridge mechanical seal** enables the **plug in replacement** of the shaft seal without disassembling the motor bracket
- The **spacer coupling** allows easy maintenance without having to remove heavy motors over 5.5 kW.

6. Smart plug solutions

Air ventilation plug / Water filling & sensor plug / Commercial sensor fitting / Measurements for suction and discharge pressure / drain

201

PRODUCT SPECIFICATIONS EVMS(.)1-3-5-10-15-20

		PUMP																		
Version		EVMSG						EVMS						EVMSL						
Operating range	Nominal flow rate (m ³ /h)	1	3	5	10	15	20	1	3	5	10	15	20	1	3	5	10	15	20	
	Maximum working pressure	1.6 / 2.5 MPa (16 bar/ 25 bar)																		
	Liquid temperature range	-30°C to 140°C																		
Key Components Material	Impeller	EN 1.4301 (AISI 304)						EN 1.4401 (AISI 316)												
	Intermediate casing	EN 1.4301 (AISI 304)						EN 1.4401 (AISI 316)												
	Liner ring	EN 1.4301 (AISI 304) + PPS						EN 1.4401 (AISI 316) + PPS												
	Bottom casing	Cast Iron			EN 1.4301 (AISI 304)			EN 1.4401 (AISI 316)												
	Casing cover	EN 1.4301 (AISI 304)						EN 1.4401 (AISI 316)												
	Shaft	EN 1.4301 (AISI 304)	EVMSG / EVMS 1-3-10 , EVMSG / EVMS 5-15-20 (depend on models)																	
		EN 1.4404 (AISI 316L)	EVMSL 1-3-10 , EVMSL 5-15-20 (depend on models)																	
		EN 1.4462 (AISI 329A)	EVMSG / EVMS / EVMSL 5-15-20 (depend on models)																	
	Shaft sleeve bearing	Tungsten carbide																		
	Shaft Seal	See the shaft seal options																		
	O-ring	EPDM	●	●	●	●	●	●	●	●	●	●	●	●	●	●	●	●	●	●
		FPM	○	○	○	○	○	○	○	○	○	○	○	○	○	○	○	○	○	○
	Outer casing	EN 1.4301 (AISI 304)						EN 1.4404 (AISI 316L)												
	Motor Bracket	Cast Iron																		
	Tie rod	Galvanized steel 6.8 strength class ISO 898/1																		
Coupling	up to 4 kW	Die cast aluminium																		
	from 5.5 kW	Cast Iron																		
Base	Cast Iron						Die cast aluminium													
	Oval flange	up to 16 bar	●	●	●	●	●	●	●	●	●	●	●	●	●	●	●	●	●	●
Round flange (DIN)	up to 16 bar	○	○	○	○	○	○	○	○	○	○	○	○	○	○	○	○	○	○	
	from 16 bar to 25 bar	●	●	●	●	●	●	●	●	●	●	●	●	●	●	●	●	●	●	
Loose round flange (DIN)	up to 16 bar							○	○	○	○	○	○	○	○	○	○	○	○	
	from 16 bar to 25 bar							○	○	○	○	○	○	○	○	○	○	○	○	
Victaulic®	up to 16/25 bar							○	○	○	○	○	○	○	○	○	○	○	○	
Clamp	up to 16/25 bar							○	○	○	○	○	○	○	○	○	○	○	○	

Legend: ● Standard ○ Options

		MOTOR		
Power Source	Frequency	50 Hz		
	Phase	Single Phase	Three Phase	
	Rotation speed	≈ 2900 min ⁻¹		
	Power rating	0.37 ÷ 2.2 kW	0.37 ÷ 18.5 kW	
		0.5 ÷ 3.0 HP	0.5 ÷ 25 HP	
Voltage	230 ± 10% V	230/400 ± 10% V (up to 4kW) 400/690 ± 10% V (above 5.5 kW)		
Type	Type	Electric - TEFC		
	Efficiency Level	from 0.37 up to 2.2 kW	- from 0.37 up to 0.55 kW IE3 above 0.75 kW	
	No' of poles	2		
	Protection degree	IP 55		
	Insulation Class	F (temperature rise class B)		
Others	Thermal Protection	PTC is available for the above 1.5 kW		
	Casing Material	Aluminium		
	Flange mount (IEC motor)	IM B14 (up to 4 kW) IM B5 (above 5.5 kW)		

SHAFT SEAL
EVMS(.)1-3-5-10-15-20

1. Shaft Seal

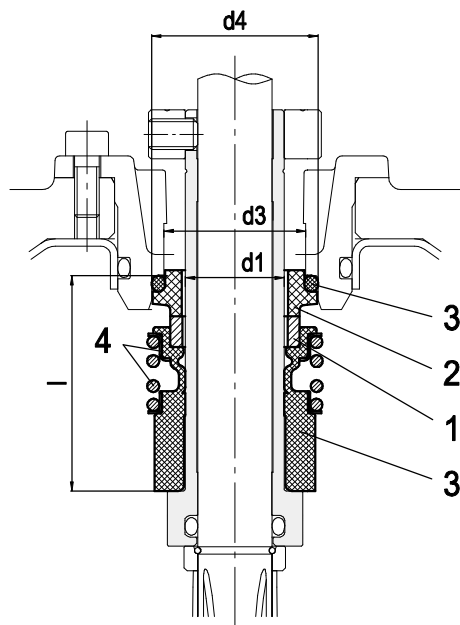

up to 16 bar
Cartridge Unbalanced type

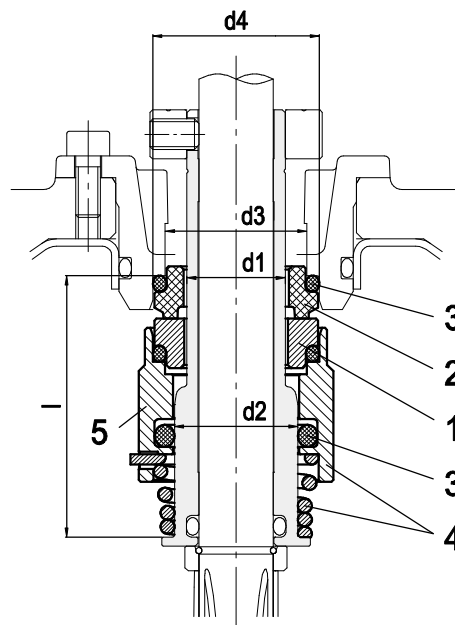

from 16 to 25 bar
Cartridge Balanced type

2. Type of Shaft Seal and Dimensions [mm]

Pump model	Max operating temperature	Shaft seal type		Shaft seal material									Type key
		Cartridge		1 Rotating Part	Code	2 Stationary Part	Code	3 Elastomers	Code	4 Compression spring	5 Collar	Code	
		Unbalanced	Balanced										
up to 16 bar	- 30°C to + 120°C	●		SiC	(Q1)	Carbon	(B)	EPDM	(E)	AISI 316	(G)	Q1BEG	
	- 30°C to + 80°C	○		SiC	(Q1)	Carbon	(B)	FPM	(V)	AISI 316	(G)	Q1BVG	
	- 30°C to + 140°C		○	SiC with graphite	(Q9)	SiC	(Q1)	EPDM	(E)	AISI 316	(G)	HQ9Q1EG	
	- 30°C to + 80°C		○	SiC with graphite	(Q9)	SiC	(Q1)	FPM	(V)	AISI 316	(G)	HQ9Q1VG	
	- 30°C to + 140°C		○	SiC	(Q1)	Carbon	(B)	EPDM	(E)	AISI 316	(G)	HQ1BEG	
from 16 bar to 25 bar	- 30°C to + 140°C		●	SiC	(Q1)	Carbon	(B)	EPDM	(E)	AISI 316	(G)	HQ1BEG	
	- 30°C to + 80°C		○	SiC	(Q1)	Carbon	(B)	FPM	(V)	AISI 316	(G)	HQ1BVG	
	- 30°C to + 140°C		○	SiC with graphite	(Q9)	SiC	(Q1)	EPDM	(E)	AISI 316	(G)	HQ9Q1EG	
	- 30°C to + 80°C		○	SiC with graphite	(Q9)	SiC	(Q1)	FPM	(V)	AISI 316	(G)	HQ9Q1VG	

● standard ○ options

Pump model	Shaft seal type		Max operating pressure	d1 [mm]	d2 [mm]	d3 [mm]	d4 [mm]	l [mm]
EVMS 1/3/5	Cartridge	Unbalanced	16 bar	16	-	23	27	35
		Balanced	25 bar		20			42.5
EVMS 10/15/20	Cartridge	Unbalanced	16 bar	20	-	29	35	37.5
		Balanced	25 bar		24			45

TYPE KEY EVMS(.)1-3-5-10-15-20

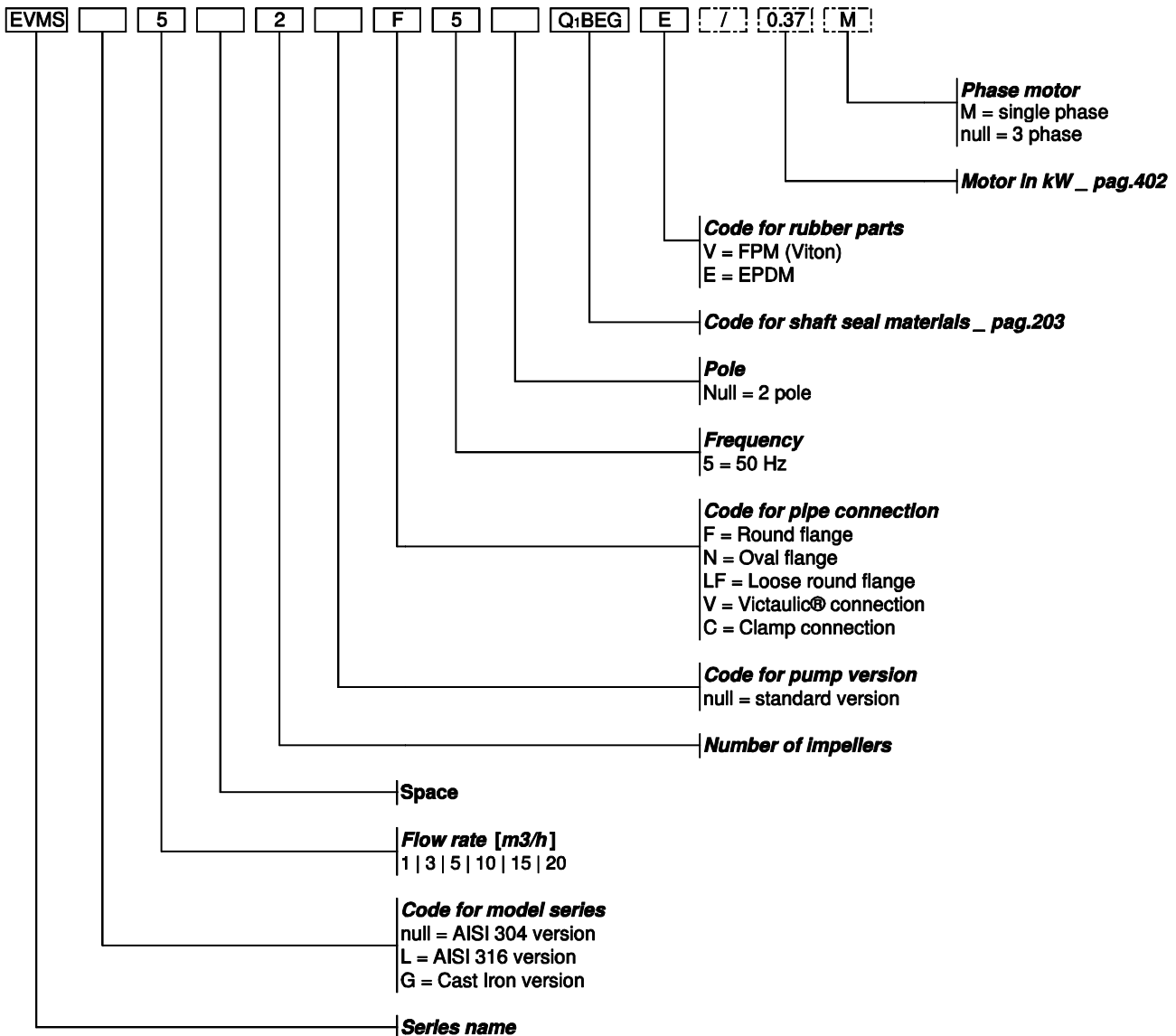

Example for **pump without motor**
EVMS5 2F5Q1BEGE

Example for **pump with motor**
EVMS5 2F5Q1BEGE/0.37M

NAMEPLATE

P.IVA 0123456789012		EBARA		Via Campo Sportivo, 30 38023 Cles (TN) - ITALY		CE		MADE IN ITALY	
TYPE	①								
○	Hmax	④	m	Hmin	⑤	m	○		
Q	②	l/min		H	③	m			
P2	⑥	KW	Hz	⑧	min ⁻¹	⑨			
HP	⑦	P/N		⑩					
MEI >	⑪	Hyd. eff.		⑫	%				

- 1) "TYPE" Pump model
- 2) "Q" Indicates upper and lower flow rate limits
- 3) "H" Indicates head limits corresponding to minimum and maximum flow rate
- 4) "Hmax" Maximum head
- 5) "Hmin" Minimum head
- 6) "P2" Rated power of the motor (output at shaft)
- 7) "HP" Rated power of the motor expressed in HP (Horse Power)
- 8) "Hz" Frequency
- 9) "min-1" Speed of rotation
- 10) "P/N" Pump item number
- 11) "MEI" Index of the pump's quality in relation to its efficiency
- 12) "Hyd. Eff. " Hydraulic efficiency of the pump

PERFORMANCE RANGE
EVMS(.)1-3-5-10-15-20

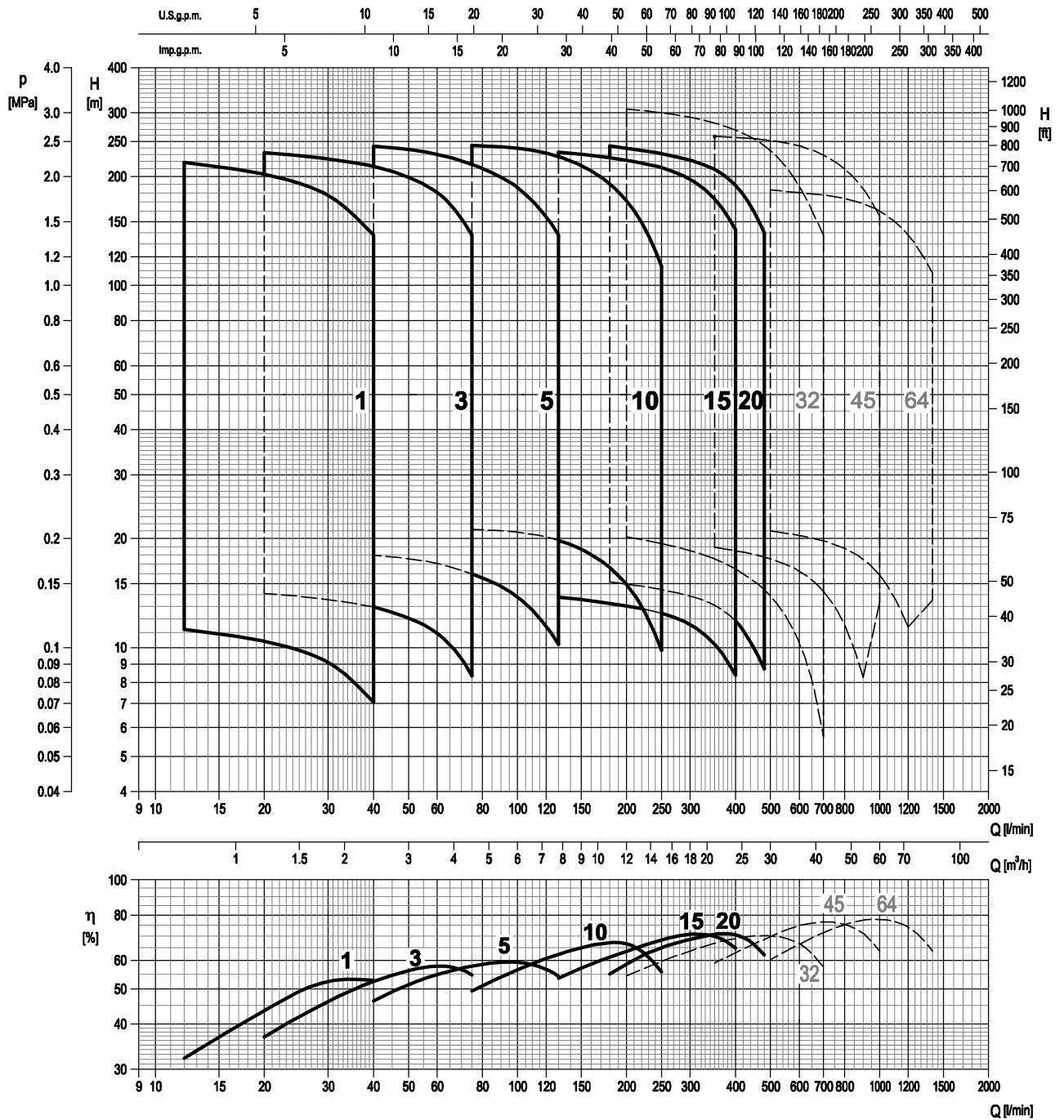

CURVE SPECIFICATIONS

The specifications below qualify the curves shown on the following pages.

Tolerances according to ISO 9906:2012 - Grade 3B.

The curves refer to effective speed of asynchronous motors at 50 Hz, 2 poles.

Measurements were carried out with clean water at 20°C of temperature and with a kinematic viscosity of $\nu = 1 \text{ mm}^2/\text{s}$ (1 cSt).

The NPSH curve is an average curve obtained in the same conditions of performance curves.

During the pump selection, consider to get a safety margin of at least 0.5 m.

The continuous curves indicate the recommended working range. The dotted curve is only a guide.

In order to avoid the risk of over-heating, the pumps should not be used at a flow rate below 10% of best efficiency point.

Symbols explanation:

Q	=	volume flow rate
H	=	total head
P_2	=	pump power input (shaft power)
η	=	pump efficiency
NPSH	=	net positive suction head required by the pump
MEI	=	minimum efficiency index

The minimum efficiency index (MEI) is a measure of the quality of a pump size in respect to its mean efficiency. The minimum efficiency index is based on the hydraulic efficiency and on the head at the best efficiency point.

The efficiency of a pump with trimmed impeller is usually lower than that of a pump with the full impeller diameter. The trimming of the impeller will adapt the pump to a fixed duty point, leading to a reduced energy consumption. The minimum efficiency index (MEI) is based on the full impeller diameter.

The operation of these water pumps with variable duty points may be more efficient and economical when controlled, for example, by the use of a variable speed drive that matches the pump duty to the system.

Minimum efficiency index (MEI)

Pump type	MEI
EVMS(.)1	> 0.70
EVMS(.)3	> 0.70
EVMS(.)5	> 0.70
EVMS(.)10	> 0.70
EVMS(.)15	> 0.70
EVMS(.)20	> 0.70

SELECTION CHART
EVMS(.)1-3-5

EVMS _ SELECTION CHART

	Pump Type		Motor			Maximum working pressure (MPa)	Q=Capacity										
	Single phase	Three phase	kW	HP	Size		H=Total manometric head in meters										
							l/min	0	12	20	30	40	60	75	100	130	
						m ³ /h	0	0.72	1.2	1.8	2.4	3.6	4.5	6	7.8		
1	EVMS(.)1 2/0.37M	EVMS(.)1 2/0.37	0.37	0.5	71	1.6	11.9	11.2	10.4	9.1	7.1	-	-	-	-	-	
	EVMS(.)1 3/0.37M	EVMS(.)1 3/0.37	0.37	0.5	71		17.9	16.8	15.6	13.6	10.6	-	-	-	-	-	-
	EVMS(.)1 4/0.37M	EVMS(.)1 4/0.37	0.37	0.5	71		23.8	22.4	20.8	18.2	14.2	-	-	-	-	-	-
	EVMS(.)1 5/0.37M	EVMS(.)1 5/0.37	0.37	0.5	71		30	28	26	22.7	17.7	-	-	-	-	-	-
	EVMS(.)1 6/0.37M	EVMS(.)1 6/0.37	0.37	0.5	71		35.8	33.6	31.2	27.3	21.2	-	-	-	-	-	-
	EVMS(.)1 7/0.37M	EVMS(.)1 7/0.37	0.37	0.5	71		41.5	39.2	36.4	31.8	24.8	-	-	-	-	-	-
	EVMS(.)1 8/0.37M	EVMS(.)1 8/0.37	0.37	0.5	71		47.5	44.5	41.5	36.4	28.3	-	-	-	-	-	-
	EVMS(.)1 9/0.55M	EVMS(.)1 9/0.55	0.55	0.75	71		53.5	50.5	47	41	31.8	-	-	-	-	-	-
	EVMS(.)1 10/0.55M	EVMS(.)1 10/0.55	0.55	0.75	71		59.6	56	52	45.5	35.4	-	-	-	-	-	-
	EVMS(.)1 11/0.55M	EVMS(.)1 11/0.55	0.55	0.75	71		65.5	61.5	57	50	38.9	-	-	-	-	-	-
	EVMS(.)1 12/0.55M	EVMS(.)1 12/0.55	0.55	0.75	71		71.5	67	62.5	54.5	42.5	-	-	-	-	-	-
	EVMS(.)1 13/0.55M	EVMS(.)1 13/0.55	0.55	0.75	71		77.5	73	67.5	59	46	-	-	-	-	-	-
	EVMS(.)1 14/0.75M	EVMS(.)1 14/0.75	0.75	1	80		83.5	78.5	73	63.5	49.5	-	-	-	-	-	-
	EVMS(.)1 16/0.75M	EVMS(.)1 16/0.75	0.75	1	80		95.5	89.5	83	72.5	56.5	-	-	-	-	-	-
	EVMS(.)1 18/1.1M	EVMS(.)1 18/1.1	1.1	1.5	80		107	101	93.5	82	63.5	-	-	-	-	-	-
	EVMS(.)1 20/1.1M	EVMS(.)1 20/1.1	1.1	1.5	80		119	112	104	91	71	-	-	-	-	-	-
	EVMS(.)1 22/1.1M	EVMS(.)1 22/1.1	1.1	1.5	80		131	123	114	100	78	-	-	-	-	-	-
	EVMS(.)1 24/1.1M	EVMS(.)1 24/1.1	1.1	1.5	80		143	135	125	109	85	-	-	-	-	-	-
	EVMS(.)1 26/1.1M	EVMS(.)1 26/1.1	1.1	1.5	80		155	146	135	118	92	-	-	-	-	-	-
	EVMS(.)1 27/1.5M	EVMS(.)1 27/1.5	1.5	2	90 S		161	151	140	123	95.5	-	-	-	-	-	-
EVMS(.)1 29/1.5M	EVMS(.)1 29/1.5	1.5	2	90 S	173	163	151	132	103	-	-	-	-	-	-		
EVMS(.)1 32/1.5M	EVMS(.)1 32/1.5	1.5	2	90 S	191	179	166	145	113	-	-	-	-	-	-		
EVMS(.)1 34/1.5M	EVMS(.)1 34/1.5	1.5	2	90 S	203	191	177	155	120	-	-	-	-	-	-		
EVMS(.)1 37/2.2M	EVMS(.)1 37/2.2	2.2	3	90 L	221	207	192	168	131	-	-	-	-	-	-		
EVMS(.)1 39/2.2M	EVMS(.)1 39/2.2	2.2	3	90 L	232	219	203	177	138	-	-	-	-	-	-		
3	EVMS(.)3 2/0.37M	EVMS(.)3 2/0.37	0.37	0.5	71	1.6	14.7	-	14.1	13.6	12.9	10.9	8.3	-	-		
	EVMS(.)3 3/0.37M	EVMS(.)3 3/0.37	0.37	0.5	71		22.1	-	21.1	20.4	19.4	16.4	12.5	-	-		
	EVMS(.)3 4/0.37M	EVMS(.)3 4/0.37	0.37	0.5	71		29.5	-	28.2	27.1	25.8	21.9	16.7	-	-		
	EVMS(.)3 5/0.55M	EVMS(.)3 5/0.55	0.55	0.75	71		36.9	-	35.2	33.9	32.3	27.4	20.9	-	-		
	EVMS(.)3 6/0.55M	EVMS(.)3 6/0.55	0.55	0.75	71		44.2	-	42.5	40.5	38.8	32.8	25	-	-		
	EVMS(.)3 7/0.75M	EVMS(.)3 7/0.75	0.75	1	80		51.5	-	49.5	47.5	45	38.3	29.2	-	-		
	EVMS(.)3 8/0.75M	EVMS(.)3 8/0.75	0.75	1	80		59	-	56.5	54.5	51.5	44	33.4	-	-		
	EVMS(.)3 9/1.1M	EVMS(.)3 9/1.1	1.1	1.5	80		66.5	-	63.5	61	58	49	37.6	-	-		
	EVMS(.)3 10/1.1M	EVMS(.)3 10/1.1	1.1	1.5	80		73.5	-	70.5	68	64.5	54.5	41.5	-	-		
	EVMS(.)3 11/1.1M	EVMS(.)3 11/1.1	1.1	1.5	80		81	-	77.5	74.5	71	60	46	-	-		
	EVMS(.)3 12/1.1M	EVMS(.)3 12/1.1	1.1	1.5	80		88.5	-	84.5	81.5	77.5	65.5	50	-	-		
	EVMS(.)3 13/1.5M	EVMS(.)3 13/1.5	1.5	2	90 S		96	-	91.5	88	84	71	54.5	-	-		
	EVMS(.)3 14/1.5M	EVMS(.)3 14/1.5	1.5	2	90 S		103	-	98.5	95	90.5	76.5	58.5	-	-		
	EVMS(.)3 15/1.5M	EVMS(.)3 15/1.5	1.5	2	90 S		111	-	106	102	97	82	62.5	-	-		
	EVMS(.)3 16/1.5M	EVMS(.)3 16/1.5	1.5	2	90 S		118	-	113	109	103	87.5	67	-	-		
	EVMS(.)3 17/2.2M	EVMS(.)3 17/2.2	2.2	3	90 L		125	-	120	115	110	93	71	-	-		
	EVMS(.)3 19/2.2M	EVMS(.)3 19/2.2	2.2	3	90 L		140	-	134	129	123	104	79.5	-	-		
	EVMS(.)3 21/2.2M	EVMS(.)3 21/2.2	2.2	3	90 L		155	-	148	142	136	115	87.5	-	-		
	EVMS(.)3 23/2.2M	EVMS(.)3 23/2.2	2.2	3	90 L		170	-	162	156	149	126	96	-	-		
	EVMS(.)3 24/2.2M	EVMS(.)3 24/2.2	2.2	3	90 L		177	-	169	163	155	131	100	-	-		
-	EVMS(.)3 25/3.0	3.0	4	100 L	184	-	176	170	161	137	104	-	-				
-	EVMS(.)3 27/3.0	3.0	4	100 L	199	-	190	183	174	148	113	-	-				
-	EVMS(.)3 29/3.0	3.0	4	100 L	214	-	204	197	187	159	121	-	-				
-	EVMS(.)3 31/3.0	3.0	4	100 L	229	-	218	210	200	170	129	-	-				
-	EVMS(.)3 33/3.0	3.0	4	100 L	243	-	232	224	213	181	138	-	-				
5	EVMS(.)5 2/0.37M	EVMS(.)5 2/0.37	0.37	0.5	71	1.6	19	-	-	-	18	17.1	16	13.8	10.2		
	EVMS(.)5 3/0.55M	EVMS(.)5 3/0.55	0.55	0.75	71		28.4	-	-	-	26.9	25.6	23.9	20.7	15.3		
	EVMS(.)5 4/0.75M	EVMS(.)5 4/0.75	0.75	1	80		37.9	-	-	-	35.9	34.1	31.9	27.6	20.4		
	EVMS(.)5 5/1.1M	EVMS(.)5 5/1.1	1.1	1.5	80		47.5	-	-	-	45	42.5	39.9	34.5	25.5		
	EVMS(.)5 6/1.5M	EVMS(.)5 6/1.5	1.5	2	90 S		57	-	-	-	54	51	48	41.5	30.6		
	EVMS(.)5 7/1.5M	EVMS(.)5 7/1.5	1.5	2	90 S		66.5	-	-	-	63	59.5	56	48.5	35.7		
	EVMS(.)5 8/2.2M	EVMS(.)5 8/2.2	2.2	3	90 L		76	-	-	-	72	68	64	55	41		
	EVMS(.)5 9/2.2M	EVMS(.)5 9/2.2	2.2	3	90 L		85.5	-	-	-	81	77	72	62	46		
	EVMS(.)5 10/2.2M	EVMS(.)5 10/2.2	2.2	3	90 L		95	-	-	-	90	85.5	80	69	51		
	EVMS(.)5 11/2.2M	EVMS(.)5 11/2.2	2.2	3	90 L		104	-	-	-	98.5	94	87.5	76	56		
	-	EVMS(.)5 12/3.0	3.0	4	100 L		114	-	-	-	108	102	95.5	83	61		
	-	EVMS(.)5 13/3.0	3.0	4	100 L		123	-	-	-	117	111	104	89.5	66.5		
	-	EVMS(.)5 14/3.0	3.0	4	100 L		133	-	-	-	126	119	112	96.5	71.5		
	-	EVMS(.)5 15/3.0	3.0	4	100 L		142	-	-	-	135	128	120	104	76.5		
	-	EVMS(.)5 17/4.0	4.0	5.5	112 M		161	-	-	-	153	145	136	117	86.5		
	-	EVMS(.)5 19/4.0	4.0	5.5	112 M		180	-	-	-	171	162	152	131	97		
	-	EVMS(.)5 20/4.0	4.0	5.5	112 M		190	-	-	-	179	171	160	138	102		
	-	EVMS(.)5 23/5.5	5.5	7.5	132 S		218	-	-	-	206	196	183	159	117		
	-	EVMS(.)5 25/5.5	5.5	7.5	132 S		237	-	-	-	224	213	199	173	127		
	-	EVMS(.)5 27/5.5	5.5	7.5	132 S		256	-	-	-	242	230	215	186	138		

1.6 MPa=16 bar ; 2.5 MPa=25 bar

SELECTION CHART EVMS(.)10-15-20

	Pump Type		Motor			Maximum working pressure (MPa)	Q-Capacity																		
							kW	HP	Size	H=Total manometric head in meters															
	Single phase	Three phase								l/min	0	75	100	130	150	180	200	250	300	350	400	450	480		
10	EVMS(.)10 2/0.75M	EVMS(.)10 2/0.75	0.75	1	80	1.6	21.8	21.2	20.8	19.7	18.7	16.6	14.9	9.8	-	-	-	-	-	-	-	-	-		
	EVMS(.)10 3/1.5M	EVMS(.)10 3/1.5	1.5	2	90 S		32.7	31.8	31.2	29.6	28.0	24.9	22.4	14.7	-	-	-	-	-	-	-	-	-	-	
	EVMS(.)10 4/2.2M	EVMS(.)10 4/2.2	2.2	3	90 L		43.6	42.4	41.7	39.5	37.3	33.2	29.8	19.6	-	-	-	-	-	-	-	-	-	-	
	EVMS(.)10 5/2.2M	EVMS(.)10 5/2.2	2.2	3	90 L		54.5	53	52	49.3	46.7	41.5	37.3	24.6	-	-	-	-	-	-	-	-	-	-	-
	EVMS(.)10 6/2.2M	EVMS(.)10 6/2.2	2.2	3	90 L		65.5	63.5	62.5	59	56	50	45	29.5	-	-	-	-	-	-	-	-	-	-	-
	-	EVMS(.)10 7/3.0	3.0	4	100 L		76.5	74	73	69	65.5	58	52	34.4	-	-	-	-	-	-	-	-	-	-	-
	-	EVMS(.)10 8/3.0	3.0	4	100 L		87.0	84.5	83.5	79	74.5	66.5	59.5	39.3	-	-	-	-	-	-	-	-	-	-	-
	-	EVMS(.)10 9/4.0	4.0	5.5	112 M		98	95.5	93.5	89	84	74.5	67	44	-	-	-	-	-	-	-	-	-	-	-
	-	EVMS(.)10 10/4.0	4.0	5.5	112 M		109	106	104	98.5	93.5	83	74.5	49	-	-	-	-	-	-	-	-	-	-	-
	-	EVMS(.)10 11/4.0	4.0	5.5	112 M		120	116	115	109	103	91.5	82	54	-	-	-	-	-	-	-	-	-	-	-
	-	EVMS(.)10 12/5.5	5.5	7.5	132 S		131	127	125	118	112	99.5	89.5	59	-	-	-	-	-	-	-	-	-	-	-
	-	EVMS(.)10 14/5.5	5.5	7.5	132 S		153	148	146	138	131	116	104	68.5	-	-	-	-	-	-	-	-	-	-	-
	-	EVMS(.)10 15/5.5	5.5	7.5	132 S		163	159	156	148	140	124	112	73.5	-	-	-	-	-	-	-	-	-	-	-
	-	EVMS(.)10 16/7.5	7.5	10	132 S		174	169	167	158	149	133	119	78.5	-	-	-	-	-	-	-	-	-	-	-
	-	EVMS(.)10 18/7.5	7.5	10	132 S		196	191	187	178	168	149	134	88.5	-	-	-	-	-	-	-	-	-	-	-
	-	EVMS(.)10 19/7.5	7.5	10	132 S		207	201	198	188	177	158	142	93.5	-	-	-	-	-	-	-	-	-	-	-
	-	EVMS(.)10 21/7.5	7.5	10	132 S		229	222	219	207	196	174	157	103	-	-	-	-	-	-	-	-	-	-	-
	-	EVMS(.)10 22/11	11	15	160 M		240	233	229	217	205	183	164	108	-	-	-	-	-	-	-	-	-	-	-
-	EVMS(.)10 23/11	11	15	160 M	251	244	240	227	215	191	172	113	-	-	-	-	-	-	-	-	-	-	-		
15	EVMS(.)15 1/1.1M	EVMS(.)15 1/1.1	1.1	1.5	80	1.6	14.9	-	-	13.3	13	12.4	12.1	10.8	9.5	7.5	4.8	-	-	-	-	-	-		
	EVMS(.)15 2/2.2M	EVMS(.)15 2/2.2	2.2	3	90 L		29.5	-	-	27.5	27.1	26	26.1	24.9	23.1	20.4	16.8	-	-	-	-	-	-	-	
	-	EVMS(.)15 3/3.0	3.0	4	100 L		44.5	-	-	41.5	40.5	39.7	39.1	37.3	34.7	30.6	25.2	-	-	-	-	-	-	-	
	-	EVMS(.)15 4/4.0	4.0	5.5	112 M		59	-	-	55	54.5	53	52	50	46.5	41	33.6	-	-	-	-	-	-	-	-
	-	EVMS(.)15 5/5.5	5.5	7.5	132 S		73.5	-	-	69	68	66	65	62	58	51	42	-	-	-	-	-	-	-	-
	-	EVMS(.)15 6/5.5	5.5	7.5	132 S		88.5	-	-	82.5	81.5	79.5	78	74.5	69.5	61	50.5	-	-	-	-	-	-	-	-
	-	EVMS(.)15 7/7.5	7.5	10	132 S		103	-	-	96.5	95.0	92.5	91	87	81	71.5	58.5	-	-	-	-	-	-	-	-
	-	EVMS(.)15 8/7.5	7.5	10	132 S		118	-	-	110	109	106	104	99.5	92.5	81.5	67	-	-	-	-	-	-	-	-
	-	EVMS(.)15 9/11	11	15	160 M		133	-	-	124	122	119	117	112	104	92	75.5	-	-	-	-	-	-	-	-
	-	EVMS(.)15 10/11	11	15	160 M		147	-	-	138	136	132	130	124	116	102	84	-	-	-	-	-	-	-	-
	-	EVMS(.)15 11/11	11	15	160 M		162	-	-	151	149	146	143	137	127	112	92.5	-	-	-	-	-	-	-	-
	-	EVMS(.)15 12/11	11	15	160 M		177	-	-	165	163	159	156	149	139	122	101	-	-	-	-	-	-	-	-
	-	EVMS(.)15 13/11	11	15	160 M		191	-	-	179	176	172	169	162	150	133	109	-	-	-	-	-	-	-	-
	-	EVMS(.)15 15/15	15	20	160 M		221	-	-	206	203	199	195	187	174	153	126	-	-	-	-	-	-	-	-
	-	EVMS(.)15 17/15	15	20	160 M		250	-	-	234	231	225	221	211	197	173	143	-	-	-	-	-	-	-	-
	20	EVMS(.)20 1/1.5M	EVMS(.)20 1/1.5	1.5	2		90 S	1.6	17.2	-	-	-	-	14.3	13.9	12.8	11.3	9.6	7.3	4.3	2.4	-	-	-	-
		-	EVMS(.)20 2/3.0	3.0	4		100 L		33.7	-	-	-	-	30.4	29.9	28.9	27.7	26.2	23.6	19.9	17.4	-	-	-	-
		-	EVMS(.)20 3/4.0	4.0	5.5		112 M		50.5	-	-	-	-	46	45	43.4	41.6	39.2	35.5	29.9	26.2	-	-	-	-
-		EVMS(.)20 4/5.5	5.5	7.5	132 S	67.4	-		-	-	-	61	60	58	55.4	52.3	47.3	39.8	34.9	-	-	-	-	-	
-		EVMS(.)20 5/7.5	7.5	10	132 S	84.2	-		-	-	-	76.0	75	72.3	69.3	65.4	59	49.8	43.6	-	-	-	-	-	
-		EVMS(.)20 6/7.5	7.5	10	132 S	101	-		-	-	-	91.2	90	87	83.1	78.5	71	59.7	52.3	-	-	-	-	-	
-		EVMS(.)20 7/11	11	15	160 M	118	-		-	-	-	106	105	101	97	91.5	82.7	70	61.1	-	-	-	-	-	
-		EVMS(.)20 8/11	11	15	160 M	135	-		-	-	-	122	120	116	111	105	95	80	70	-	-	-	-	-	
-		EVMS(.)20 9/11	11	15	160 M	152	-		-	-	-	137	135	130	125	118	106	89.6	79	-	-	-	-	-	
-		EVMS(.)20 10/11	11	15	160 M	168	-		-	-	-	152	150	145	139	131	118	100	87	-	-	-	-	-	
-		EVMS(.)20 11/15	15	20	160 M	185	-		-	-	-	167	165	159	152	144	130	110	96	-	-	-	-	-	
-		EVMS(.)20 12/15	15	20	160 M	202	-		-	-	-	182	179	173	166	157	142	119	105	-	-	-	-	-	
-		EVMS(.)20 13/15	15	20	160 M	219	-		-	-	-	198	194	188	180	170	154	129	113	-	-	-	-	-	
-		EVMS(.)20 14/18.5	18.5	25	160 L	236	-		-	-	-	213	209	202	194	183	166	139	122	-	-	-	-	-	
-		EVMS(.)20 15/18.5	18.5	25	160 L	253	-		-	-	-	228	224	217	208	196	177	149	131	-	-	-	-	-	
-		EVMS(.)20 16/18.5	18.5	25	160 L	270	-		-	-	-	243	239	231	222	209	189	159	140	-	-	-	-	-	

1.6 MPa=16 bar ; 2.5 MPa=25 bar

PERFORMANCE CURVE
EVMS(L)1

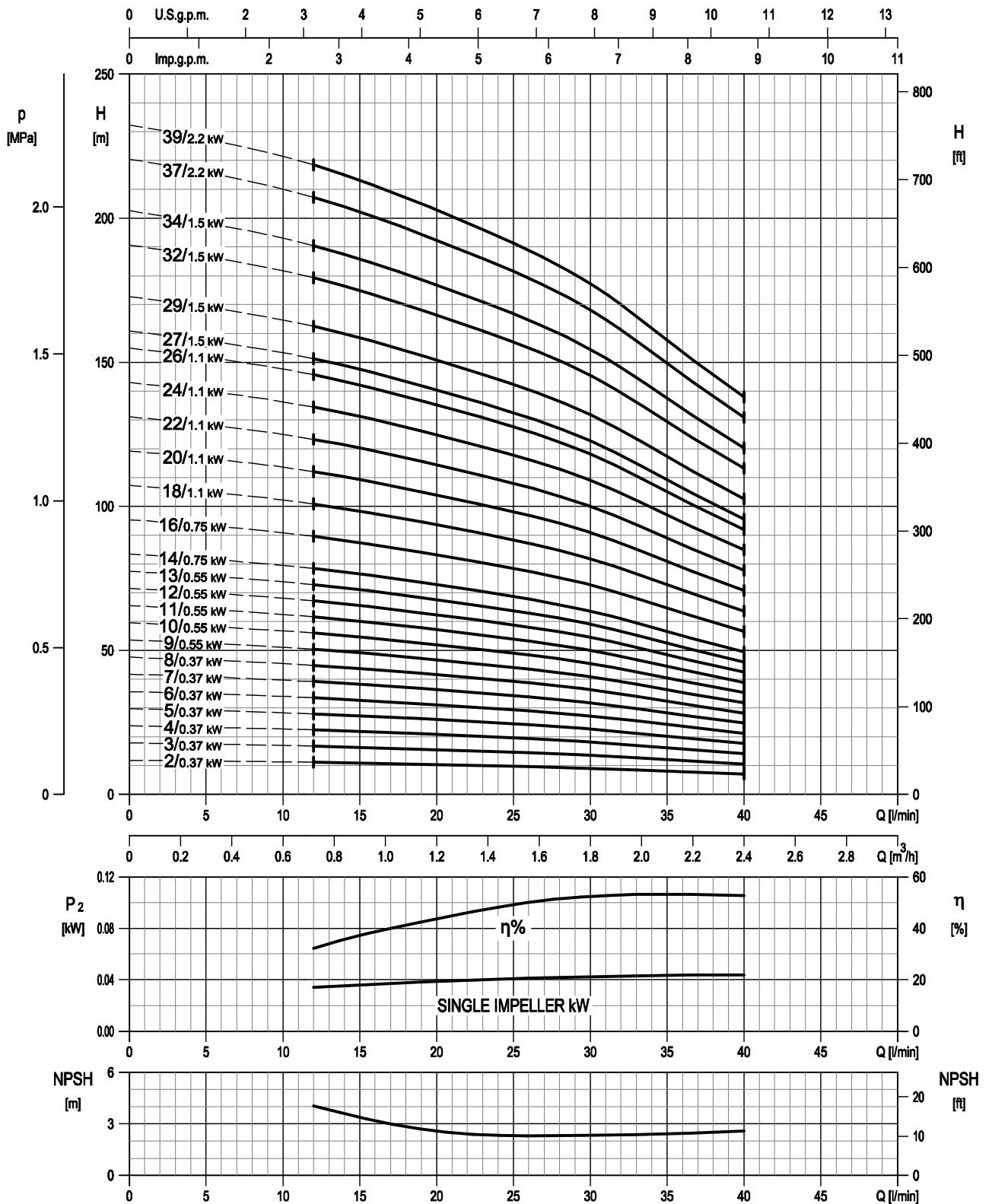

Rotation speed ≈ 2900 min⁻¹
Test standard: ISO 9906:2012 - Grade 3B

TECHNICAL DATA EVMS(L)1

Dimensional sketch

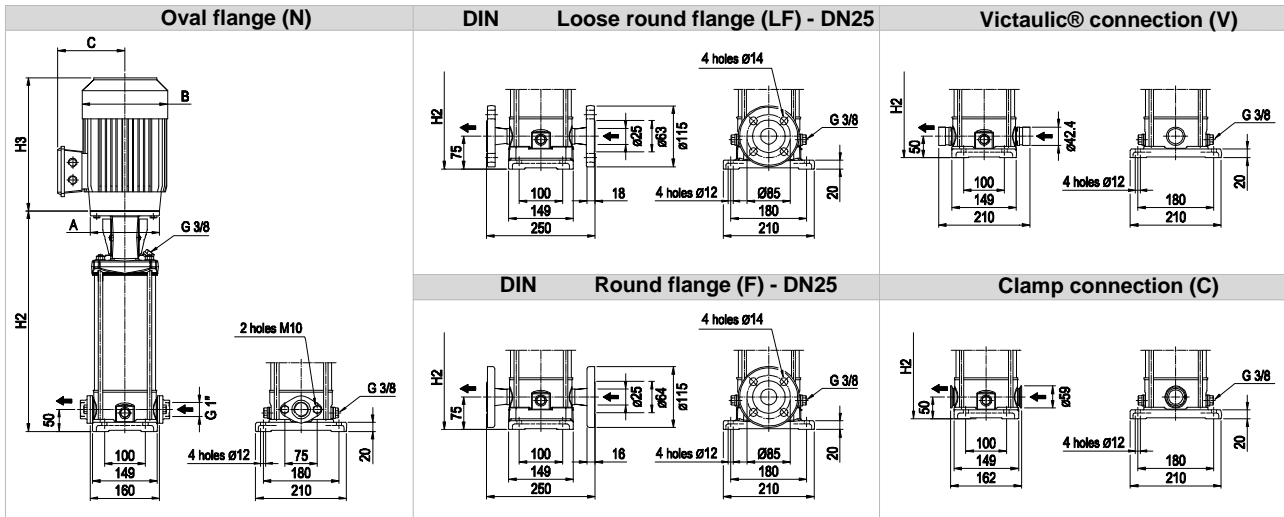

Dimensions [mm] and Weights [Kg]

Pump Type	Pmax [MPa]	KW	Motor			Oval flange (N)			Loose round flange (LF) Round flange (F)			Victaulic® connection (V) Clamp connection (C)		
			Size	A	1 ~	3 ~	H2	Weight Pump	Weight Pump + Motor	H2	Weight Pump	Weight Pump + Motor	H2	Weight Pump
EVMS(L)1 2/0.37	1.6	0.37	71	Ø105	139 133 216	139 114 216	250	9.7	16.8 15.5	275	10.4 17.5 16.2	250	9.7	16.8 15.5
EVMS(L)1 3/0.37	1.6	0.37	71	Ø105	139 133 216	139 114 216	271	10.2	17.3 16	296	10.9 18 16.7	271	10.2	17.3 16
EVMS(L)1 4/0.37	1.6	0.37	71	Ø105	139 133 216	139 114 216	292	10.6	17.7 16.4	317	11.3 18.4 17.1	292	10.6	17.7 16.4
EVMS(L)1 5/0.37	1.6	0.37	71	Ø105	139 133 216	139 114 216	313	11.1	18.2 16.9	338	11.8 18.9 17.6	313	11.1	18.2 16.9
EVMS(L)1 6/0.37	1.6	0.37	71	Ø105	139 133 216	139 114 216	334	11.5	18.6 17.3	359	12.2 19.3 18	334	11.5	18.6 17.3
EVMS(L)1 7/0.37	1.6	0.37	71	Ø105	139 133 216	139 114 216	355	11.9	19 17.7	380	12.6 19.7 18.4	355	11.9	19.0 17.7
EVMS(L)1 8/0.37	1.6	0.37	71	Ø105	139 133 216	139 114 216	376	12.4	19.5 18.2	401	13.1 20.2 18.9	376	12.4	19.5 18.2
EVMS(L)1 9/0.55	1.6	0.55	71	Ø105	139 133 216	139 114 216	397	12.8	21.3 19	422	13.5 22 19.7	397	12.8	21.3 19
EVMS(L)1 10/0.55	1.6	0.55	71	Ø105	139 133 216	139 114 216	418	13.2	21.7 19.4	443	13.9 22.4 20.1	418	13.2	21.7 19.4
EVMS(L)1 11/0.55	1.6	0.55	71	Ø105	139 133 216	139 114 216	439	13.7	22.2 19.9	464	14.4 22.9 20.6	439	13.7	22.2 19.9
EVMS(L)1 12/0.55	1.6	0.55	71	Ø105	139 133 216	139 114 216	460	14.4	22.9 20.6	485	15.1 23.6 21.3	460	14.4	22.9 20.6
EVMS(L)1 13/0.55	1.6	0.55	71	Ø105	139 133 216	139 114 216	481	15	23.5 21.2	506	15.7 24.2 21.9	481	15	23.5 21.2
EVMS(L)1 14/0.75	1.6	0.75	80	Ø120	160 151 232	160 139 232	512	15.7	27.1 25.2	537	16.4 27.8 25.9	512	15.7	27.1 25.2
EVMS(L)1 16/0.75	1.6	0.75	80	Ø120	160 151 232	160 139 232	554	16.7	28.1 26.2	579	17.4 28.8 26.9	554	16.7	28.1 26.2
EVMS(L)1 18/1.1	1.6	1.1	80	Ø120	160 151 232	160 139 232	596	17.8	29.6 28.9	621	18.5 30.3 29.6	596	17.8	29.6 28.9
EVMS(L)1 20/1.1	1.6	1.1	80	Ø120	160 151 232	160 139 232	638	18.8	30.6 29.9	663	19.5 31.3 30.6	638	18.8	30.6 29.9
EVMS(L)1 22/1.1	1.6	1.1	80	Ø120	160 151 232	160 139 232	680	20	31.8 31.1	705	20.7 32.5 31.8	680	20	31.8 31.1
EVMS(L)1 24/1.1	1.6	1.1	80	Ø120	160 151 232	160 139 232	722	21	32.8 32.1	747	21.7 33.5 32.8	722	21	32.8 32.1
EVMS(L)1 26/1.1	1.6	1.1	80	Ø120	160 151 232	160 139 232	764	22	33.8 33.1	789	22.7 34.5 33.8	764	22	33.8 33.1
EVMS(L)1 27/1.5	2.5	1.5	90 S	Ø140	172 140 278	180 148 267	-	-	-	820	23.1 40.9 35.8	795	22.4	40.2 35.1
EVMS(L)1 29/1.5	2.5	1.5	90 S	Ø140	172 140 278	180 148 267	-	-	-	862	24.1 41.9 36.8	837	23.4	41.2 36.1
EVMS(L)1 32/1.5	2.5	1.5	90 S	Ø140	172 140 278	180 148 267	-	-	-	925	25.4 43.2 38.1	900	24.7	42.5 37.4
EVMS(L)1 34/1.5	2.5	1.5	90 S	Ø140	172 140 278	180 148 267	-	-	-	967	26.3 44.1 39	942	25.6	43.4 38.3
EVMS(L)1 37/2.2	2.5	2.2	90 L	Ø140	172 140 278	180 148 267	-	-	-	1030	27.7 47.2 43.7	1005	27	46.5 43
EVMS(L)1 39/2.2	2.5	2.2	90 L	Ø140	172 140 278	180 148 267	-	-	-	1072	28.7 48.2 44.7	1047	28	47.5 44

1.6 MPa=16 bar ; 2.5 MPa=25 bar
- not available model

SECTIONAL VIEW
EVMS(L)1

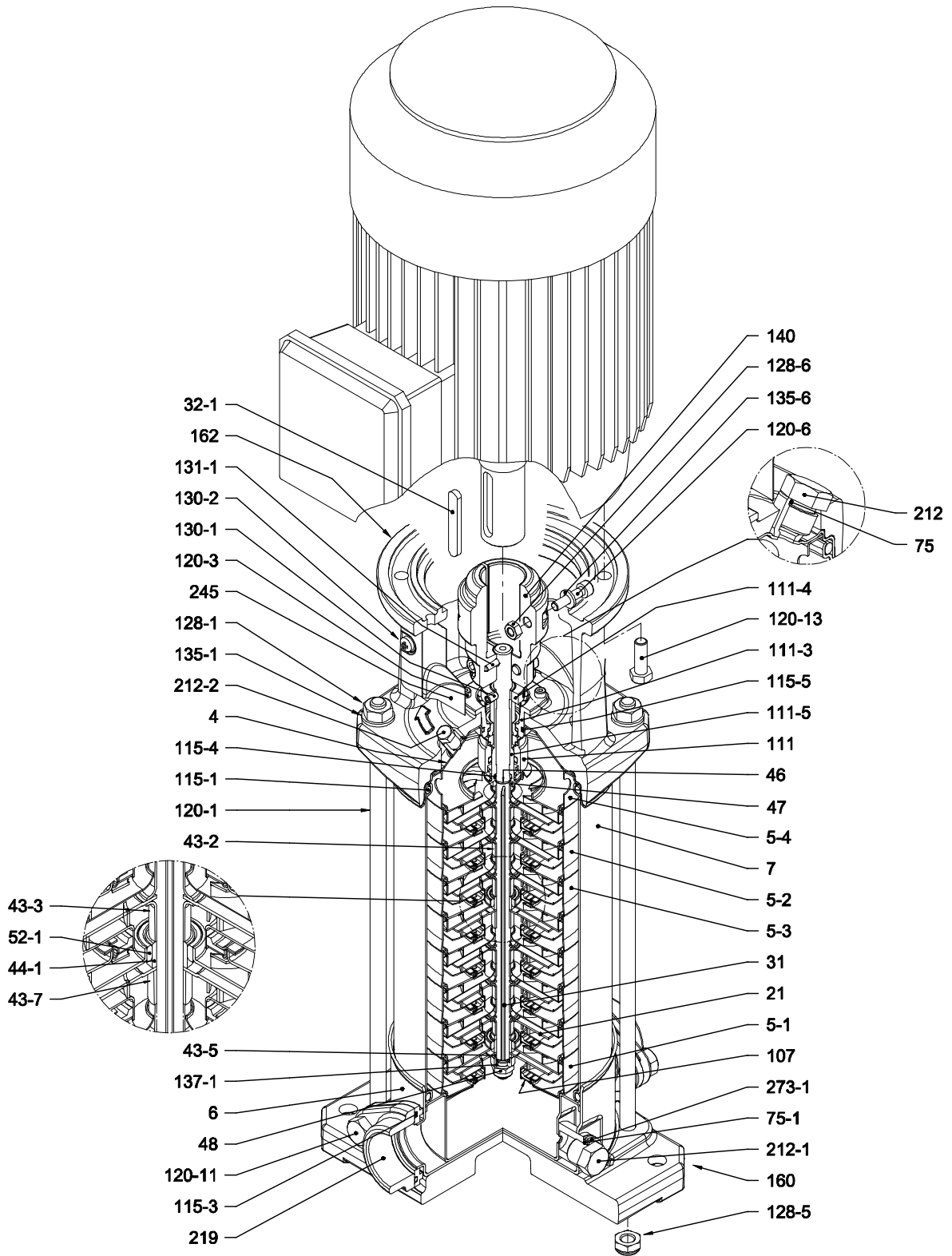

with Oval flange (N)

211

PIPE CONNECTION EVMS(L)1

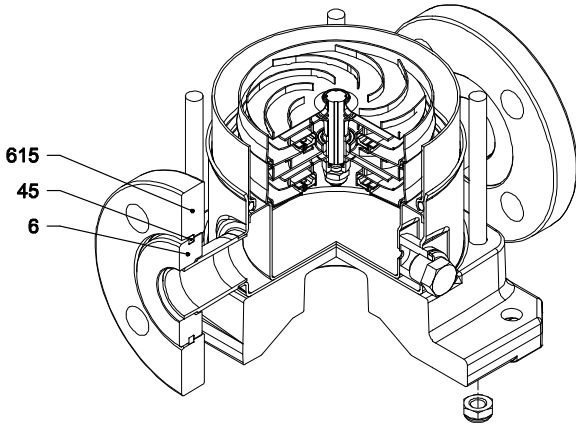

with Loose round flange (LF)

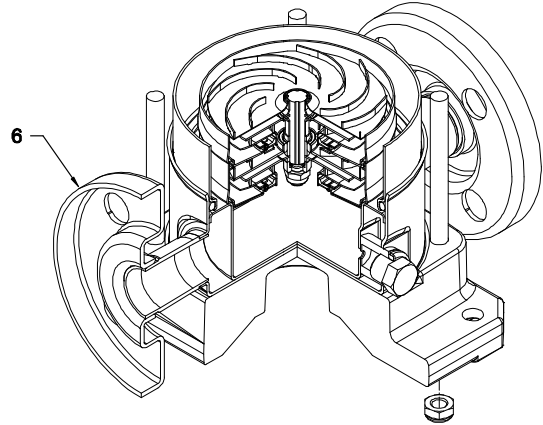

with Round flange (F)

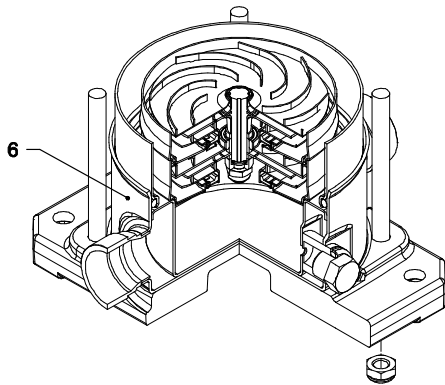

with Victaulic® connection (V)

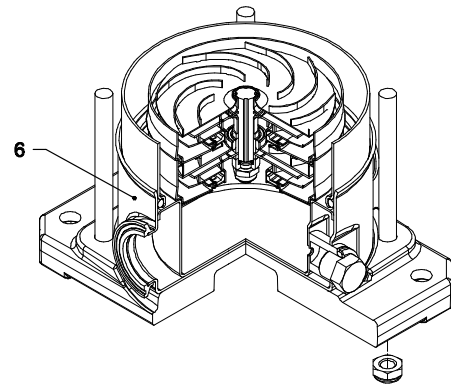

with Clamp connection (C)

SECTIONAL TABLE
EVMS(L)1

N°	PART NAME	MATERIAL		DIMENSIONS	STANDARD
		EVMS	EVMSL		
4	Casing cover	EN 1.4301 (AISI 304)	EN 1.4401 (AISI 316)		
5-1	Suction casing	EN 1.4301 (AISI 304)	EN 1.4401 (AISI 316)		
5-2	Intermediate Casing	EN 1.4301 (AISI 304)	EN 1.4401 (AISI 316)		
5-3	Intermediate casing bearing	EN 1.4301 (AISI 304)	EN 1.4401 (AISI 316)		
5-4	Discharge casing	EN 1.4301 (AISI 304)	EN 1.4401 (AISI 316)		
6	Bottom casing	EN 1.4301 (AISI 304)	EN 1.4401 (AISI 316)		
7	Outer casing	EN 1.4301 (AISI 304)	EN 1.4404 (AISI 316L)		
21	Impeller	EN 1.4301 (AISI 304)	EN 1.4401 (AISI 316)		
31	Shaft	EN 1.4301 (AISI 304)	EN 1.4404 (AISI 316L)		
32-1	Adjuster Key	EN 1.4301 (AISI 304)			
43-2	Shaft sleeve (intermediate)	EN 1.4301 (AISI 304)	EN 1.4404 (AISI 316L)		
43-3	Shaft sleeve (bearing)	EN 1.4301 (AISI 304)	EN 1.4401 (AISI 316)		
43-5	Shaft sleeve (last stage)	EN 1.4301 (AISI 304)	EN 1.4401 (AISI 316)		
43-7	Spacer	EN 1.4301 (AISI 304)	EN 1.4404 (AISI 316L)		
44-1	Shaft sleeve bearing	Tungsten carbide			
45	Flange holder	EN 1.4301 (AISI 304)			
46	Ring (mechanical seal)	EN 1.4404 (AISI 316L)			
47	Ring Holder	EN 1.4301 (AISI 304)	EN 1.4401 (AISI 316)		
48	Impeller nut	A2-70 UNI 7323 with inox insert	A4-70 UNI 7323 with inox insert	M8	
52-1	Bearing	Tungsten carbide			
75	O-Ring (plug)	EPDM		D. 12.37x2.62	OR 3050
75-1	O-Ring (plug)	EPDM			
107	Liner ring	EN 1.4301 (AISI 304) + PPS	EN 1.4401 (AISI 316) + PPS		
111	Mechanical Seal	SiC/Carbon/EPDM			
111-3	Mechanical seal seat	EN 1.4301 (AISI 304)	EN 1.4401 (AISI 316)		
111-4	Seal holder	EN 1.4301 (AISI 304)			
111-5	Mechanical seal cartridge	EN 1.4301 (AISI 304)	EN 1.4401 (AISI 316)		
115-1	O-Ring (outer casing)	EPDM		D. 129.54x5.34	OR 6510
115-3	O-Ring	EPDM			
115-4	O-Ring (cartridge sleeve)	EPDM		D. 11.91x2.62	OR 115
115-5	O-Ring (seal cover)	EPDM		D. 32.99x2.62	OR 3131
120-1	Tie-rod	Galvanized steel 6.8 strength class ISO 898/1		M10	
120-3	Screw	A2-70 UNI 7323		M4x10	ISO 4762
120-6	Screw for coupling	Galvanized steel		M6x25	ISO 4762
120-11	Screw for counterflange	A2-70 UNI 7323			
120-13	Screw for motor	MEC 71-80 MEC 90	Galvanized steel 8.8 strength class ISO 898/1	M6x20 M8x20	ISO 4017 ISO 4017
128-1	Nut for tie rod	Galvanized steel		M10	UNI 5588
128-5	Nut for tie rod	A2-70 UNI 7323		M10	UNI 7474
128-6	Nut for coupling	Galvanized steel		M6	ISO 4032
130-1	Set screw	A2-70 UNI 7323		M5x8	UNI 5923
130-2	Screw for coupling guard	A2-70 UNI 7323		M5x6	UNI 7687
131-1	Pin for shaft	Carbon Steel		D. 4x32	UNI 4838
135-1	Washer	Galvanized steel		D. 10.5x21x2	UNI 6592
135-6	Washer	Carbon Steel		Ø6	
137-1	Impeller spacer	EN 1.4301 (AISI 304)	EN 1.4401 (AISI 316)		
140	Coupling	up to 4.0 kW Die cast aluminium EN AB-AISI11Cu2 (Fe)			
160	Base	Die cast aluminium EN AB-AISI11Cu2 (Fe)			
162	Motor bracket	Cast iron EN-GJL-200-EN 1561			
212	Plug	EN 1.4301 (AISI 304)	EN 1.4401 (AISI 316)	G 3/8	
212-1	Plug	EN 1.4301 (AISI 304)	EN 1.4401 (AISI 316)	G 3/8	
212-2	Venting plug	EN 1.4404 (AISI 316L)			
219	Counter flange	EN 1.4301 (AISI 304)	EN 1.4401 (AISI 316)		
245	Coupling guard	EN 1.4301 (AISI 304)			
273-1	Plug Washer	EN 1.4301 (AISI 304)	EN 1.4401 (AISI 316)		
615	Flange	Nodular Cast Iron			

QUANTITY FOR MODEL EVMS(L)1

Pump Type	N°																															
	4	5-1	5-2	5-3	5-4	6	7	21	31	32-1	43-2	43-3	43-5	43-7	44-1	45**	46	47	48	52-1	75	75-1	107	111	111-3	111-4	111-5	115-1	115-3*	115-4	115-5	
EVMS(L)1 2/0.37	1	1	/	1	1	1	1	2	1	1	/	1	/	/	1	4	2	1	1	1	1	2	2	1	1	1	1	2	2	1	1	
EVMS(L)1 3/0.37	1	1	1	1	1	1	1	3	1	1	3	1	/	/	1	4	2	1	1	1	1	2	3	1	1	1	1	2	2	2	1	1
EVMS(L)1 4/0.37	1	1	2	1	1	1	1	4	1	1	5	1	/	/	1	4	2	1	1	1	1	2	4	1	1	1	1	2	2	2	1	1
EVMS(L)1 5/0.37	1	1	3	1	1	1	1	5	1	1	7	1	1	/	1	4	2	1	1	1	1	2	5	1	1	1	1	2	2	2	1	1
EVMS(L)1 6/0.37	1	1	4	1	1	1	1	6	1	1	9	1	1	/	1	4	2	1	1	1	1	2	6	1	1	1	1	2	2	2	1	1
EVMS(L)1 7/0.37	1	1	5	1	1	1	1	7	1	1	11	1	/	/	1	4	2	1	1	1	1	2	7	1	1	1	1	2	2	2	1	1
EVMS(L)1 8/0.37	1	1	6	1	1	1	1	8	1	1	13	1	/	/	1	4	2	1	1	1	1	2	8	1	1	1	1	2	2	2	1	1
EVMS(L)1 9/0.55	1	1	7	1	1	1	1	9	1	1	15	1	1	/	1	4	2	1	1	1	1	2	9	1	1	1	1	2	2	2	1	1
EVMS(L)1 10/0.55	1	1	8	1	1	1	1	10	1	1	17	1	/	/	1	4	2	1	1	1	1	2	10	1	1	1	1	2	2	2	1	1
EVMS(L)1 11/0.55	1	1	9	1	1	1	1	11	1	1	19	1	/	/	1	4	2	1	1	1	1	2	11	1	1	1	1	2	2	2	1	1
EVMS(L)1 12/0.55	1	1	10	1	1	1	1	12	1	1	21	1	/	/	1	4	2	1	1	1	1	2	12	1	1	1	1	2	2	2	1	1
EVMS(L)1 13/0.55	1	1	10	2	1	1	1	13	1	1	20	2	1	1	2	4	2	1	1	2	1	2	13	1	1	1	1	2	2	2	1	1
EVMS(L)1 14/0.75	1	1	11	2	1	1	1	14	1	1	22	2	/	1	2	4	2	1	1	2	1	2	14	1	1	1	1	2	2	2	1	1
EVMS(L)1 16/0.75	1	1	13	2	1	1	1	16	1	1	26	2	/	1	2	4	2	1	1	2	1	2	16	1	1	1	1	2	2	2	1	1
EVMS(L)1 18/1.1	1	1	15	2	1	1	1	18	1	1	30	2	/	1	2	4	2	1	1	2	1	2	18	1	1	1	1	2	2	2	1	1
EVMS(L)1 20/1.1	1	1	17	2	1	1	1	20	1	1	34	2	/	1	2	4	2	1	1	2	1	2	20	1	1	1	1	2	2	2	1	1
EVMS(L)1 22/1.1	1	1	19	2	1	1	1	22	1	1	38	2	/	1	2	4	2	1	1	2	1	2	22	1	1	1	1	2	2	2	1	1
EVMS(L)1 24/1.1	1	1	21	2	1	1	1	24	1	1	42	2	/	1	2	4	2	1	1	2	1	2	24	1	1	1	1	2	2	2	1	1
EVMS(L)1 26/1.1	1	1	23	2	1	1	1	26	1	1	46	2	/	1	2	4	2	1	1	2	1	2	26	1	1	1	1	2	2	2	1	1
EVMS(L)1 27/1.5	1	1	24	2	1	1	1	27	1	1	48	2	/	1	2	4	2	1	1	2	1	2	27	1	1	1	1	2	/	1	1	1
EVMS(L)1 29/1.5	1	1	26	2	1	1	1	29	1	1	52	2	/	1	2	4	2	1	1	2	1	2	29	1	1	1	1	2	/	1	1	1
EVMS(L)1 32/1.5	1	1	29	2	1	1	1	32	1	1	58	2	/	1	2	4	2	1	1	2	1	2	32	1	1	1	1	2	/	1	1	1
EVMS(L)1 34/1.5	1	1	31	2	1	1	1	34	1	1	62	2	/	1	2	4	2	1	1	2	1	2	34	1	1	1	1	2	/	1	1	1
EVMS(L)1 37/2.2	1	1	34	2	1	1	1	37	1	1	68	2	/	1	2	4	2	1	1	2	1	2	37	1	1	1	1	2	/	1	1	1
EVMS(L)1 39/2.2	1	1	36	2	1	1	1	39	1	1	72	2	/	1	2	4	2	1	1	2	1	2	39	1	1	1	1	2	/	1	1	1

Pump Type	N°																							
	120-1	120-3	120-6	120-11*	120-13	128-1	128-5	128-6	130-1	130-2	131-1	135-1	135-6	137-1	140	160	162	212	212-1	212-2	219*	245	273-1	615**
EVMS(L)1 2/0.37	4	4	4	4	4	4	4	4	3	4	1	4	4	1	2	1	1	1	2	1	2	2	2	2
EVMS(L)1 3/0.37	4	4	4	4	4	4	4	4	3	4	1	4	4	1	2	1	1	1	2	1	2	2	2	2
EVMS(L)1 4/0.37	4	4	4	4	4	4	4	4	3	4	1	4	4	1	2	1	1	1	2	1	2	2	2	2
EVMS(L)1 5/0.37	4	4	4	4	4	4	4	4	3	4	1	4	4	1	2	1	1	1	2	1	2	2	2	2
EVMS(L)1 6/0.37	4	4	4	4	4	4	4	4	3	4	1	4	4	1	2	1	1	1	2	1	2	2	2	2
EVMS(L)1 7/0.37	4	4	4	4	4	4	4	4	3	4	1	4	4	1	2	1	1	1	2	1	2	2	2	2
EVMS(L)1 8/0.37	4	4	4	4	4	4	4	4	3	4	1	4	4	1	2	1	1	1	2	1	2	2	2	2
EVMS(L)1 9/0.55	4	4	4	4	4	4	4	4	3	4	1	4	4	1	2	1	1	1	2	1	2	2	2	2
EVMS(L)1 10/0.55	4	4	4	4	4	4	4	4	3	4	1	4	4	1	2	1	1	1	2	1	2	2	2	2
EVMS(L)1 11/0.55	4	4	4	4	4	4	4	4	3	4	1	4	4	1	2	1	1	1	2	1	2	2	2	2
EVMS(L)1 12/0.55	4	4	4	4	4	4	4	4	3	4	1	4	4	1	2	1	1	1	2	1	2	2	2	2
EVMS(L)1 13/0.55	4	4	4	4	4	4	4	4	3	4	1	4	4	1	2	1	1	1	2	1	2	2	2	2
EVMS(L)1 14/0.75	4	4	4	4	4	4	4	4	3	4	1	4	4	1	2	1	1	1	2	1	2	2	2	2
EVMS(L)1 16/0.75	4	4	4	4	4	4	4	4	3	4	1	4	4	1	2	1	1	1	2	1	2	2	2	2
EVMS(L)1 18/1.1	4	4	4	4	4	4	4	4	3	4	1	4	4	1	2	1	1	1	2	1	2	2	2	2
EVMS(L)1 20/1.1	4	4	4	4	4	4	4	4	3	4	1	4	4	1	2	1	1	1	2	1	2	2	2	2
EVMS(L)1 22/1.1	4	4	4	4	4	4	4	4	3	4	1	4	4	1	2	1	1	1	2	1	2	2	2	2
EVMS(L)1 24/1.1	4	4	4	4	4	4	4	4	3	4	1	4	4	1	2	1	1	1	2	1	2	2	2	2
EVMS(L)1 26/1.1	4	4	4	4	4	4	4	4	3	4	1	4	4	1	2	1	1	1	2	1	2	2	2	2
EVMS(L)1 27/1.5	4	4	4	/	4	4	4	4	3	4	1	4	4	1	2	1	1	1	2	1	/	2	2	2
EVMS(L)1 29/1.5	4	4	4	/	4	4	4	4	3	4	1	4	4	1	2	1	1	1	2	1	/	2	2	2
EVMS(L)1 32/1.5	4	4	4	/	4	4	4	4	3	4	1	4	4	1	2	1	1	1	2	1	/	2	2	2
EVMS(L)1 34/1.5	4	4	4	/	4	4	4	4	3	4	1	4	4	1	2	1	1	1	2	1	/	2	2	2
EVMS(L)1 37/2.2	4	4	4	/	4	4	4	4	3	4	1	4	4	1	2	1	1	1	2	1	/	2	2	2
EVMS(L)1 39/2.2	4	4	4	/	4	4	4	4	3	4	1	4	4	1	2	1	1	1	2	1	/	2	2	2

* only for Oval flange (N)

** only for Loose round flange (LF)

PERFORMANCE CURVE
EVMSG1

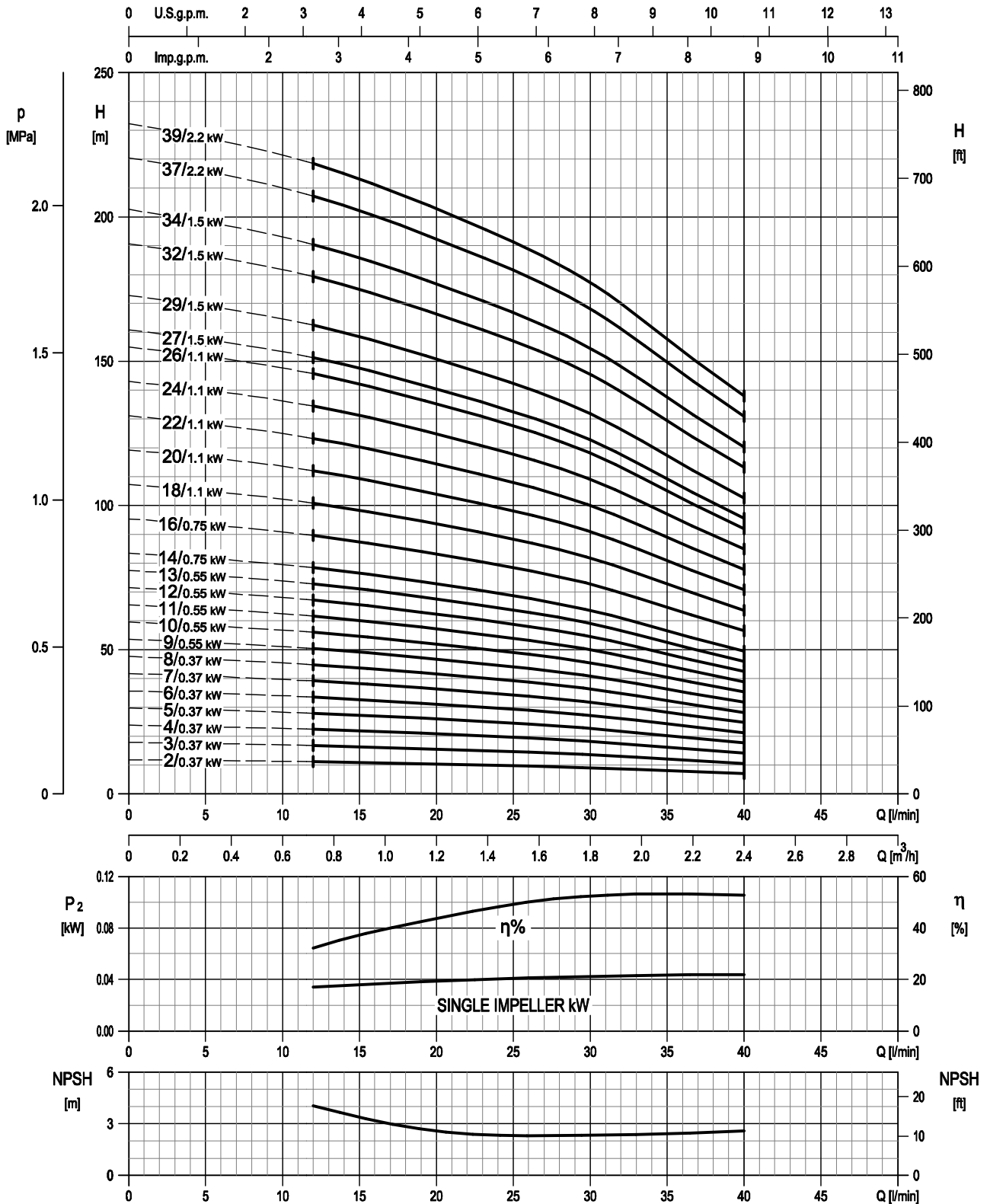

Rotation speed $\approx 2900 \text{ min}^{-1}$
Test standard: ISO 9906:2012 - Grade 3B

TECHNICAL DATA EVMSG1

Dimensional sketch

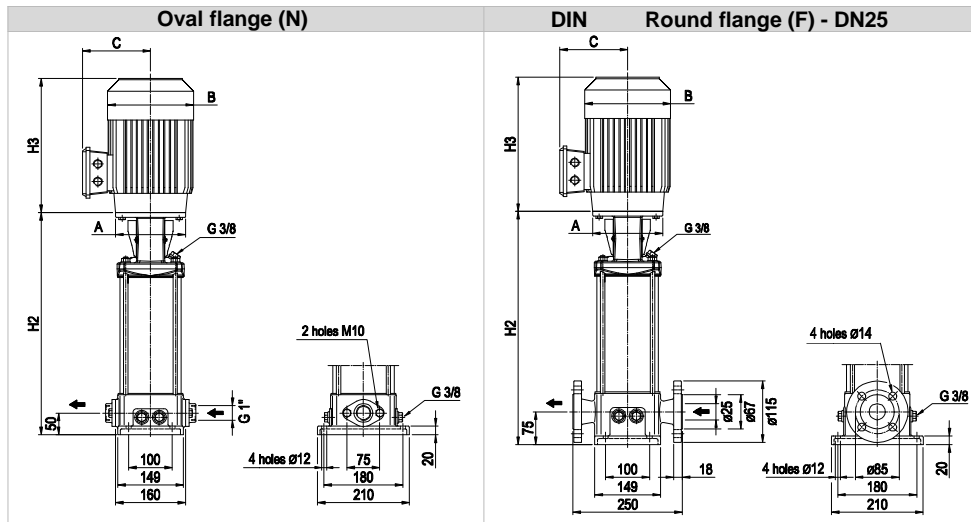

Dimensions [mm] and Weights [Kg]

Pump Type	Pmax [MPa]	kW	Motor									Oval flange (N)			Round flange (F)			
			Size	1 ~			3 ~			H2	Weight Pump	Weight Pump + Motor		H2	Weight Pump	Weight Pump + Motor		
				A	B	C	H3	B	C			H3	1 ~			3 ~	1 ~	3 ~
EVMSG1 2/0.37	1.6	0.37	71	ø105	139	133	216	139	114	216	250	14	21.1	19.8	275	17.4	24.5	23.2
EVMSG1 3/0.37	1.6	0.37	71	ø105	139	133	216	139	114	216	271	14.5	21.6	20.3	296	17.9	25	23.7
EVMSG1 4/0.37	1.6	0.37	71	ø105	139	133	216	139	114	216	292	14.9	22	20.7	317	18.3	25.4	24.1
EVMSG1 5/0.37	1.6	0.37	71	ø105	139	133	216	139	114	216	313	15.4	22.5	21.2	338	18.8	25.9	24.6
EVMSG1 6/0.37	1.6	0.37	71	ø105	139	133	216	139	114	216	334	15.8	22.9	21.6	359	19.2	26.3	25
EVMSG1 7/0.37	1.6	0.37	71	ø105	139	133	216	139	114	216	355	16.2	23.3	22	380	19.6	26.7	25.4
EVMSG1 8/0.37	1.6	0.37	71	ø105	139	133	216	139	114	216	376	16.7	23.8	22.5	401	20.1	27.2	25.9
EVMSG1 9/0.55	1.6	0.55	71	ø105	139	133	216	139	114	216	397	17.1	25.6	23.3	422	20.5	29	26.7
EVMSG1 10/0.55	1.6	0.55	71	ø105	139	133	216	139	114	216	418	17.5	26	23.7	443	20.9	29.4	27.1
EVMSG1 11/0.55	1.6	0.55	71	ø105	139	133	216	139	114	216	439	18	26.5	24.2	464	21.4	29.9	27.6
EVMSG1 12/0.55	1.6	0.55	71	ø105	139	133	216	139	114	216	460	18.7	27.2	24.9	485	22.1	30.6	28.3
EVMSG1 13/0.55	1.6	0.55	71	ø105	139	133	216	139	114	216	481	19.3	27.8	25.5	506	22.7	31.2	28.9
EVMSG1 14/0.75	1.6	0.75	80	ø120	160	151	232	160	139	232	512	20	31.4	29.5	537	23.4	34.8	32.9
EVMSG1 16/0.75	1.6	0.75	80	ø120	160	151	232	160	139	232	554	21	32.4	30.5	579	24.4	35.8	33.9
EVMSG1 18/1.1	1.6	1.1	80	ø120	160	151	232	160	139	232	596	22.1	33.9	33.2	621	25.5	37.3	36.6
EVMSG1 20/1.1	1.6	1.1	80	ø120	160	151	232	160	139	232	638	23.1	34.9	34.2	663	26.5	38.3	37.6
EVMSG1 22/1.1	1.6	1.1	80	ø120	160	151	232	160	139	232	680	24.3	36.1	35.4	705	27.7	39.5	38.8
EVMSG1 24/1.1	1.6	1.1	80	ø120	160	151	232	160	139	232	722	25.3	37.1	36.4	747	28.7	40.5	39.8
EVMSG1 26/1.1	1.6	1.1	80	ø120	160	151	232	160	139	232	764	26.3	38.1	37.4	789	29.7	41.5	40.8
EVMSG1 27/1.5	2.5	1.5	90 S	ø140	172	140	278	180	148	267	-	-	-	-	820	30.1	47.9	42.8
EVMSG1 29/1.5	2.5	1.5	90 S	ø140	172	140	278	180	148	267	-	-	-	-	862	31.1	48.9	43.8
EVMSG1 32/1.5	2.5	1.5	90 S	ø140	172	140	278	180	148	267	-	-	-	-	925	32.4	50.2	45.1
EVMSG1 34/1.5	2.5	1.5	90 S	ø140	172	140	278	180	148	267	-	-	-	-	967	33.3	51.1	46
EVMSG1 37/2.2	2.5	2.2	90 L	ø140	172	140	278	180	148	267	-	-	-	-	1030	34.7	54.2	50.7
EVMSG1 39/2.2	2.5	2.2	90 L	ø140	172	140	278	180	148	267	-	-	-	-	1072	35.7	55.2	51.7

1.6 MPa=16 bar ; 2.5 MPa=25 bar
- not available model

SECTIONAL VIEW
EVMSG1

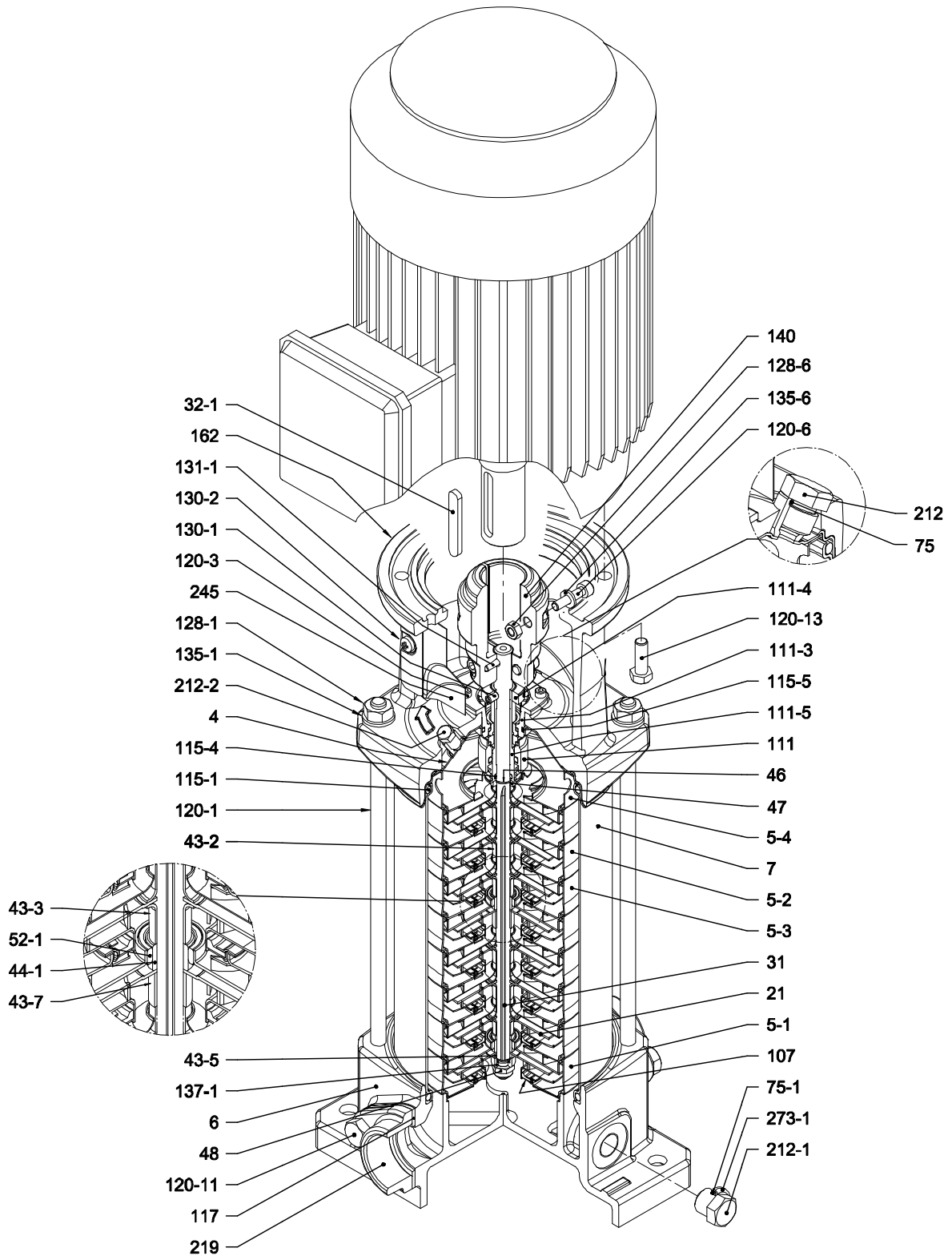

with Oval flange (N)

PIPE CONNECTION EVMSG1

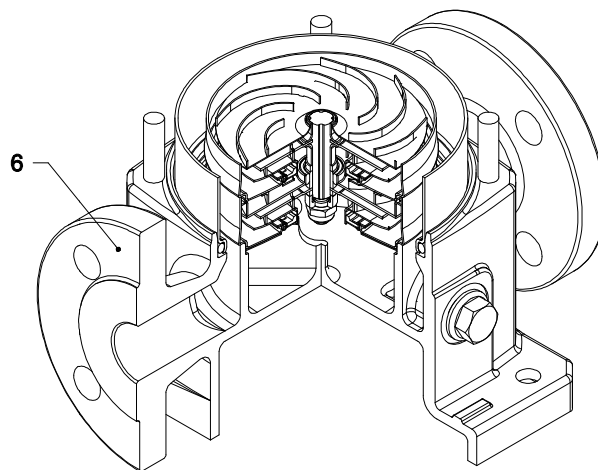

with Round flange (F)

EVMSG1

SECTIONAL TABLE
EVMSG1

N°	PART NAME	MATERIAL EVMSG	DIMENSIONS	STANDARD	
4	Casing cover	EN 1.4301 (AISI 304)			
5-1	Suction casing	EN 1.4301 (AISI 304)			
5-2	Intermediate Casing	EN 1.4301 (AISI 304)			
5-3	Intermediate casing bearing	EN 1.4301 (AISI 304)			
5-4	Discharge casing	EN 1.4301 (AISI 304)			
6	Bottom casing	Cast Iron EN G.JL-250-EN1561			
7	Outer casing	EN 1.4301 (AISI 304)			
21	Impeller	EN 1.4301 (AISI 304)			
31	Shaft	EN 1.4301 (AISI 304)			
32-1	Adjuster Key	EN 1.4301 (AISI 304)			
43-2	Shaft sleeve (intermediate)	EN 1.4301 (AISI 304)			
43-3	Shaft sleeve (bearing)	EN 1.4301 (AISI 304)			
43-5	Shaft sleeve (last stage)	EN 1.4301 (AISI 304)			
43-7	Spacer	EN 1.4301 (AISI 304)			
44-1	Shaft sleeve bearing	Tungsten carbide			
46	Ring (mechanical seal)	EN 1.4404 (AISI 316L)			
47	Ring Holder	EN 1.4301 (AISI 304)			
48	Impeller nut	A2-70 UNI 7323 with inox insert	M8		
52-1	Bearing	Tungsten carbide			
75	O-Ring (plug)	EPDM	D. 12.37x2.62	OR 3050	
75-1	O-Ring (plug)	EPDM			
107	Liner ring	EN 1.4301 (AISI 304) + PPS			
111	Mechanical Seal	SiC/Carbon/EPDM			
111-3	Mechanical seal seat	EN 1.4301 (AISI 304)			
111-4	Seal holder	EN 1.4301 (AISI 304)			
111-5	Mechanical seal cartridge	EN 1.4301 (AISI 304)			
115-1	O-Ring (outer casing)	EPDM	D. 129.54x5.34	OR 6510	
115-4	O-Ring (cartridge sleeve)	EPDM	D. 11.91x2.62	OR 115	
115-5	O-Ring (seal cover)	EPDM	D. 32.99x2.62	OR 3131	
117	Flange gasket	EPDM			
120-1	Tie-rod	Galvanized steel 6.8 strength class ISO 898/1	M10		
120-3	Screw	A2-70 UNI 7323	M4x10	ISO 4762	
120-6	Screw for coupling	Galvanized steel	M6x25	ISO 4762	
120-11	Screw for counterflange	A2-70 UNI 7323			
120-13	Screw for motor	Galvanized steel 8.8 strength class ISO 898/1	MEC 71-80	M6x20	ISO 4017
			MEC 90	M8x20	ISO 4017
128-1	Nut for tie rod	Galvanized steel	M10	UNI 5588	
128-6	Nut for coupling	Galvanized steel	M6	ISO 4032	
130-1	Set screw	A2-70 UNI 7323	M5x8	UNI 5923	
130-2	Screw for coupling guard	A2-70 UNI 7323	M5x6	UNI 7687	
131-1	Pin for shaft	Carbon Steel	D. 4x32	UNI 4838	
135-1	Washer	Galvanized steel	D. 10.5x21x2	UNI 6592	
135-6	Washer	Carbon Steel	Ø6		
137-1	Impeller spacer	EN 1.4301 (AISI 304)			
140	Coupling	up to 4.0 kW	Die cast Aluminium EN AB-AISI11Cu2 (Fe)		
162	Motor bracket	Cast iron EN-G.JL-200-EN 1561			
212	Plug	EN 1.4301 (AISI 304)	G 3/8		
212-1	Plug	EN 1.4301 (AISI 304)	G 3/8		
212-2	Venting plug	EN 1.4404 (AISI 316L)			
219	Counter flange	Galvanized steel			
245	Coupling guard	EN 1.4301 (AISI 304)			
273-1	Plug Washer	EN 1.4301 (AISI 304)			

QUANTITY FOR MODEL EVMSG1

Pump Type	N°																												
	4	5-1	5-2	5-3	5-4	6	7	21	31	32-1	43-2	43-3	43-5	43-7	44-1	46	47	48	52-1	75	75-1	107	111	111-3	111-4	111-5	115-1	115-4	115-5
EVMSG1 2/0.37	1	1	/	1	1	1	1	2	1	1	/	1	/	/	1	2	1	1	1	1	4	2	1	1	1	1	2	1	1
EVMSG1 3/0.37	1	1	1	1	1	1	1	3	1	1	3	1	/	/	1	2	1	1	1	1	4	3	1	1	1	1	2	1	1
EVMSG1 4/0.37	1	1	2	1	1	1	1	4	1	1	5	1	/	/	1	2	1	1	1	1	4	4	1	1	1	1	2	1	1
EVMSG1 5/0.37	1	1	3	1	1	1	1	5	1	1	7	1	1	/	1	2	1	1	1	1	4	5	1	1	1	1	2	1	1
EVMSG1 6/0.37	1	1	4	1	1	1	1	6	1	1	9	1	/	/	1	2	1	1	1	1	4	6	1	1	1	1	2	1	1
EVMSG1 7/0.37	1	1	5	1	1	1	1	7	1	1	11	1	/	/	1	2	1	1	1	1	4	7	1	1	1	1	2	1	1
EVMSG1 8/0.37	1	1	6	1	1	1	1	8	1	1	13	1	/	/	1	2	1	1	1	1	4	8	1	1	1	1	2	1	1
EVMSG1 9/0.55	1	1	7	1	1	1	1	9	1	1	15	1	1	/	1	2	1	1	1	1	4	9	1	1	1	1	2	1	1
EVMSG1 10/0.55	1	1	8	1	1	1	1	10	1	1	17	1	/	/	1	2	1	1	1	1	4	10	1	1	1	1	2	1	1
EVMSG1 11/0.55	1	1	9	1	1	1	1	11	1	1	19	1	/	/	1	2	1	1	1	1	4	11	1	1	1	1	2	1	1
EVMSG1 12/0.55	1	1	10	1	1	1	1	12	1	1	21	1	/	/	1	2	1	1	1	1	4	12	1	1	1	1	2	1	1
EVMSG1 13/0.55	1	1	10	2	1	1	1	13	1	1	20	2	1	1	2	2	1	1	2	1	4	13	1	1	1	1	2	1	1
EVMSG1 14/0.75	1	1	11	2	1	1	1	14	1	1	22	2	/	1	2	2	1	1	2	1	4	14	1	1	1	1	2	1	1
EVMSG1 16/0.75	1	1	13	2	1	1	1	16	1	1	26	2	/	1	2	2	1	1	2	1	4	16	1	1	1	1	2	1	1
EVMSG1 18/1.1	1	1	15	2	1	1	1	18	1	1	30	2	/	1	2	2	1	1	2	1	4	18	1	1	1	1	2	1	1
EVMSG1 20/1.1	1	1	17	2	1	1	1	20	1	1	34	2	/	1	2	2	1	1	2	1	4	20	1	1	1	1	2	1	1
EVMSG1 22/1.1	1	1	19	2	1	1	1	22	1	1	38	2	/	1	2	2	1	1	2	1	4	22	1	1	1	1	2	1	1
EVMSG1 24/1.1	1	1	21	2	1	1	1	24	1	1	42	2	/	1	2	2	1	1	2	1	4	24	1	1	1	1	2	1	1
EVMSG1 26/1.1	1	1	23	2	1	1	1	26	1	1	46	2	/	1	2	2	1	1	2	1	4	26	1	1	1	1	2	1	1
EVMSG1 27/1.5	1	1	24	2	1	1	1	27	1	1	48	2	/	1	2	2	1	1	2	1	4	27	1	1	1	1	2	1	1
EVMSG1 29/1.5	1	1	26	2	1	1	1	29	1	1	52	2	/	1	2	2	1	1	2	1	4	29	1	1	1	1	2	1	1
EVMSG1 32/1.5	1	1	29	2	1	1	1	32	1	1	58	2	/	1	2	2	1	1	2	1	4	32	1	1	1	1	2	1	1
EVMSG1 34/1.5	1	1	31	2	1	1	1	34	1	1	62	2	/	1	2	2	1	1	2	1	4	34	1	1	1	1	2	1	1
EVMSG1 37/2.2	1	1	34	2	1	1	1	37	1	1	68	2	/	1	2	2	1	1	2	1	4	37	1	1	1	1	2	1	1
EVMSG1 39/2.2	1	1	36	2	1	1	1	39	1	1	72	2	/	1	2	2	1	1	2	1	4	39	1	1	1	1	2	1	1

Pump Type	N°																					
	117*	120-1	120-3	120-6	120-11*	120-13	128-1	128-6	130-1	130-2	131-1	135-1	135-6	137-1	140	162	212	212-1	212-2	219*	245	273-1
EVMSG1 2/0.37	2	4	4	4	4	4	4	4	3	4	1	4	4	1	2	1	1	4	1	2	2	4
EVMSG1 3/0.37	2	4	4	4	4	4	4	4	3	4	1	4	4	1	2	1	1	4	1	2	2	4
EVMSG1 4/0.37	2	4	4	4	4	4	4	4	3	4	1	4	4	1	2	1	1	4	1	2	2	4
EVMSG1 5/0.37	2	4	4	4	4	4	4	4	3	4	1	4	4	1	2	1	1	4	1	2	2	4
EVMSG1 6/0.37	2	4	4	4	4	4	4	4	3	4	1	4	4	1	2	1	1	4	1	2	2	4
EVMSG1 7/0.37	2	4	4	4	4	4	4	4	3	4	1	4	4	1	2	1	1	4	1	2	2	4
EVMSG1 8/0.37	2	4	4	4	4	4	4	4	3	4	1	4	4	1	2	1	1	4	1	2	2	4
EVMSG1 9/0.55	2	4	4	4	4	4	4	4	3	4	1	4	4	1	2	1	1	4	1	2	2	4
EVMSG1 10/0.55	2	4	4	4	4	4	4	4	3	4	1	4	4	1	2	1	1	4	1	2	2	4
EVMSG1 11/0.55	2	4	4	4	4	4	4	4	3	4	1	4	4	1	2	1	1	4	1	2	2	4
EVMSG1 12/0.55	2	4	4	4	4	4	4	4	3	4	1	4	4	1	2	1	1	4	1	2	2	4
EVMSG1 13/0.55	2	4	4	4	4	4	4	4	3	4	1	4	4	1	2	1	1	4	1	2	2	4
EVMSG1 14/0.75	2	4	4	4	4	4	4	4	3	4	1	4	4	1	2	1	1	4	1	2	2	4
EVMSG1 16/0.75	2	4	4	4	4	4	4	4	3	4	1	4	4	1	2	1	1	4	1	2	2	4
EVMSG1 18/1.1	2	4	4	4	4	4	4	4	3	4	1	4	4	1	2	1	1	4	1	2	2	4
EVMSG1 20/1.1	2	4	4	4	4	4	4	4	3	4	1	4	4	1	2	1	1	4	1	2	2	4
EVMSG1 22/1.1	2	4	4	4	4	4	4	4	3	4	1	4	4	1	2	1	1	4	1	2	2	4
EVMSG1 24/1.1	2	4	4	4	4	4	4	4	3	4	1	4	4	1	2	1	1	4	1	2	2	4
EVMSG1 26/1.1	2	4	4	4	4	4	4	4	3	4	1	4	4	1	2	1	1	4	1	2	2	4
EVMSG1 27/1.5	/	4	4	4	/	4	4	4	3	4	1	4	4	1	2	1	1	4	1	/	2	4
EVMSG1 29/1.5	/	4	4	4	/	4	4	4	3	4	1	4	4	1	2	1	1	4	1	/	2	4
EVMSG1 32/1.5	/	4	4	4	/	4	4	4	3	4	1	4	4	1	2	1	1	4	1	/	2	4
EVMSG1 34/1.5	/	4	4	4	/	4	4	4	3	4	1	4	4	1	2	1	1	4	1	/	2	4
EVMSG1 37/2.2	/	4	4	4	/	4	4	4	3	4	1	4	4	1	2	1	1	4	1	/	2	4
EVMSG1 39/2.2	/	4	4	4	/	4	4	4	3	4	1	4	4	1	2	1	1	4	1	/	2	4

* only for Oval flange (N)

PERFORMANCE CURVE
EVMS(L)3

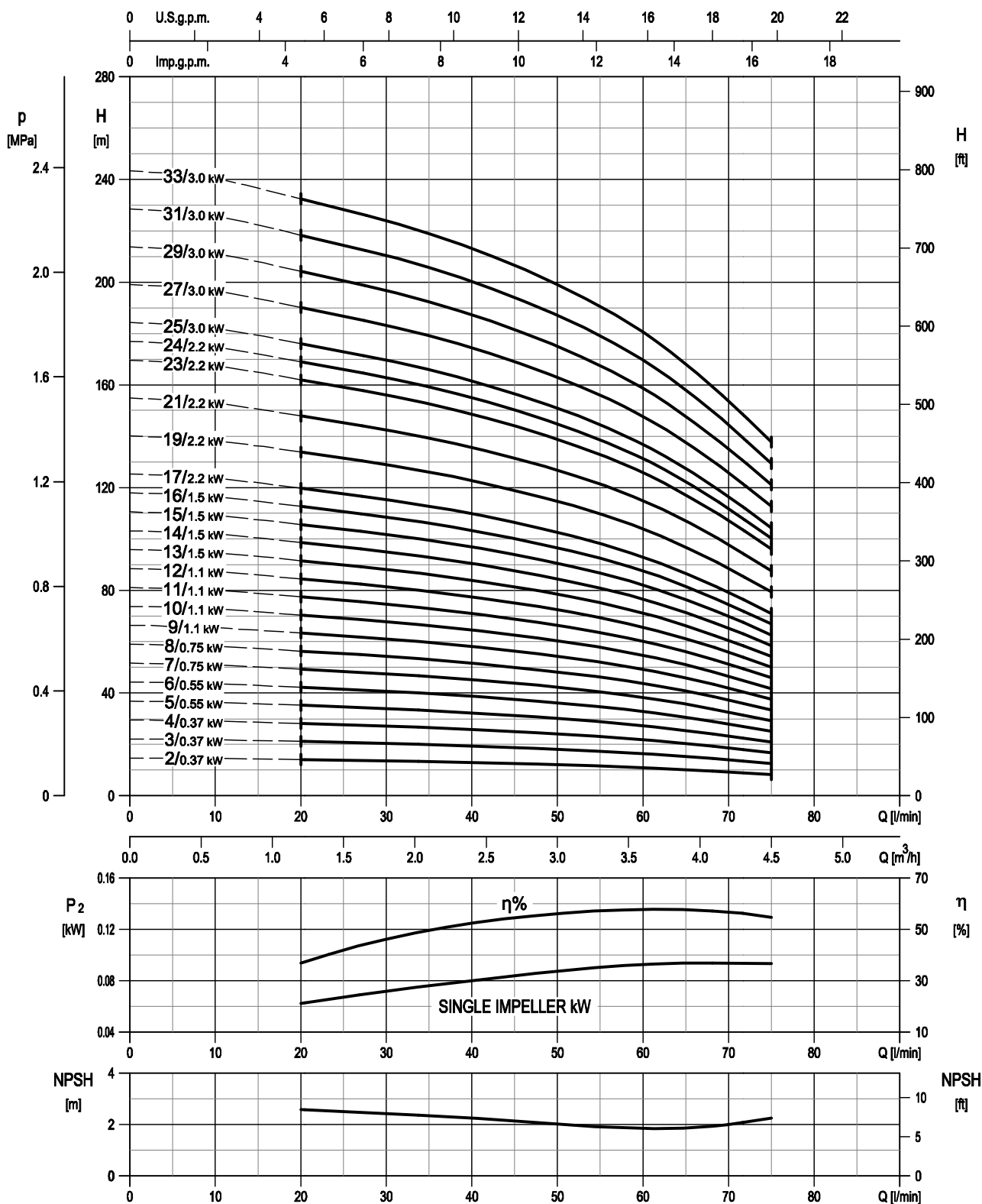

Rotation speed ≈ 2900 min⁻¹
Test standard: ISO 9906:2012 - Grade 3B

TECHNICAL DATA EVMS(L)3

Dimensional sketch

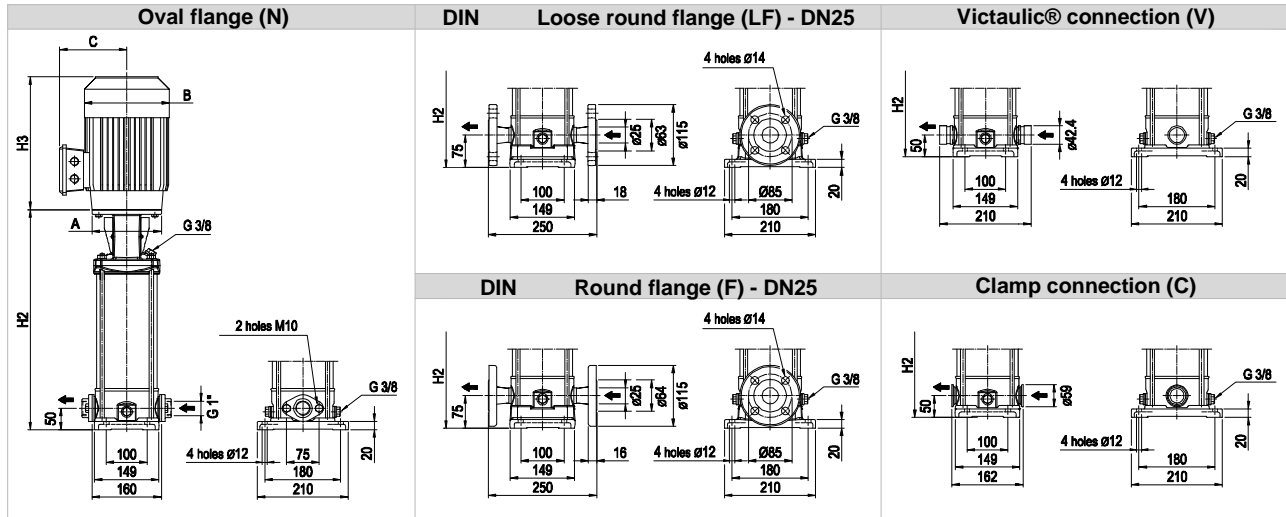

Dimensions [mm] and Weights [Kg]

Pump Type	Pmax [MPa]	kW	Motor									Oval flange (N)			Loose round flange (LF) Round flange (F)			Victaulic® connection (V) Clamp connection (C)				
			Size	1 ~			3 ~			H2	Weight Pump	Weight Pump + Motor		H2	Weight Pump	Weight Pump + Motor		H2	Weight Pump	Weight Pump + Motor		
				A	B	C	H3	B	C			H3	1 ~			3 ~	1 ~			3 ~	1 ~	3 ~
EVMS(L)3 2/0.37	1.6	0.37	71	Ø105	139	133	216	139	114	216	250	9.7	16.8	15.5	275	10.5	17.6	16.3	250	9.7	16.8	15.5
EVMS(L)3 3/0.37	1.6	0.37	71	Ø105	139	133	216	139	114	216	271	10.1	17.2	15.9	296	10.9	18	16.7	271	10.2	17.3	16
EVMS(L)3 4/0.37	1.6	0.37	71	Ø105	139	133	216	139	114	216	292	10.6	17.7	16.4	317	11.3	18.4	17.1	292	10.6	17.7	16.4
EVMS(L)3 5/0.55	1.6	0.55	71	Ø105	139	133	216	139	114	216	313	11	19.5	17.2	338	11.8	20.3	18	313	11.1	19.6	17.3
EVMS(L)3 6/0.55	1.6	0.55	71	Ø105	139	133	216	139	114	216	334	11.4	19.9	17.6	359	12.2	20.7	18.4	334	11.5	20	17.7
EVMS(L)3 7/0.75	1.6	0.75	80	Ø120	160	151	232	160	139	232	365	12.4	23.8	21.9	390	13.1	24.5	22.6	365	12.4	23.8	21.9
EVMS(L)3 8/0.75	1.6	0.75	80	Ø120	160	151	232	160	139	232	386	12.8	24.2	22.3	411	13.6	25	23.1	386	12.9	24.3	22.4
EVMS(L)3 9/1.1	1.6	1.1	80	Ø120	160	151	232	160	139	232	407	13.2	25	24.3	432	14	25.8	25.1	407	13.3	25.1	24.4
EVMS(L)3 10/1.1	1.6	1.1	80	Ø120	160	151	232	160	139	232	428	13.7	25.5	24.8	453	14.5	26.3	25.6	428	13.7	25.5	24.8
EVMS(L)3 11/1.1	1.6	1.1	80	Ø120	160	151	232	160	139	232	449	14.1	25.9	25.2	474	14.9	26.7	26	449	14.2	26	25.3
EVMS(L)3 12/1.1	1.6	1.1	80	Ø120	160	151	232	160	139	232	470	14.6	26.4	25.7	495	15.4	27.2	26.5	470	14.6	26.4	25.7
EVMS(L)3 13/1.5	1.6	1.5	90 S	Ø140	172	140	278	180	148	267	501	15.3	33.1	28.0	526	16.1	33.9	28.8	501	15.3	33.1	28
EVMS(L)3 14/1.5	1.6	1.5	90 S	Ø140	172	140	278	180	148	267	522	15.7	33.5	28.4	547	16.5	34.3	29.2	522	15.8	33.6	28.5
EVMS(L)3 15/1.5	1.6	1.5	90 S	Ø140	172	140	278	180	148	267	543	16.2	34	28.9	568	17	34.8	30	543	16.3	34.1	29
EVMS(L)3 16/1.5	1.6	1.5	90 S	Ø140	172	140	278	180	148	267	564	17.3	35.1	30.0	589	18	35.8	31	564	17.3	35.1	30
EVMS(L)3 17/2.2	1.6	2.2	90 L	Ø140	172	140	278	180	148	267	585	17.7	37.2	33.7	610	18.5	38	34.5	585	17.7	37.2	33.7
EVMS(L)3 19/2.2	1.6	2.2	90 L	Ø140	172	140	278	180	148	267	627	18.7	38.2	34.7	652	19.5	39	35.5	627	18.7	38.2	34.7
EVMS(L)3 21/2.2	1.6	2.2	90 L	Ø140	172	140	278	180	148	267	669	19.6	39.1	35.6	694	20.4	39.9	36.4	669	19.6	39.1	35.6
EVMS(L)3 23/2.2	2.5	2.2	90 L	Ø140	172	140	278	180	148	267	-	-	-	736	21.4	40.9	37.4	711	20.6	40.1	36.6	
EVMS(L)3 24/2.2	2.5	2.2	90 L	Ø140	172	140	278	180	148	267	-	-	-	757	21.8	41.3	37.8	732	21.1	40.6	37.1	
EVMS(L)3 25/3.0	2.5	3.0	100 L	Ø160	-	-	-	196	155	306	-	-	-	788	22.4	-	45.2	763	21.7	-	44.5	
EVMS(L)3 27/3.0	2.5	3.0	100 L	Ø160	-	-	-	196	155	306	-	-	-	830	23.4	-	46.2	805	22.6	-	45.4	
EVMS(L)3 29/3.0	2.5	3.0	100 L	Ø160	-	-	-	196	155	306	-	-	-	872	24.3	-	47.1	847	23.6	-	46.4	
EVMS(L)3 31/3.0	2.5	3.0	100 L	Ø160	-	-	-	196	155	306	-	-	-	914	25.3	-	48.1	889	24.6	-	47.4	
EVMS(L)3 33/3.0	2.5	3.0	100 L	Ø160	-	-	-	196	155	306	-	-	-	956	26.1	-	48.9	931	25.4	-	48.2	

1.6 MPa=16 bar ; 2.5 MPa=25 bar
- not available model

SECTIONAL VIEW
EVMS(L)3

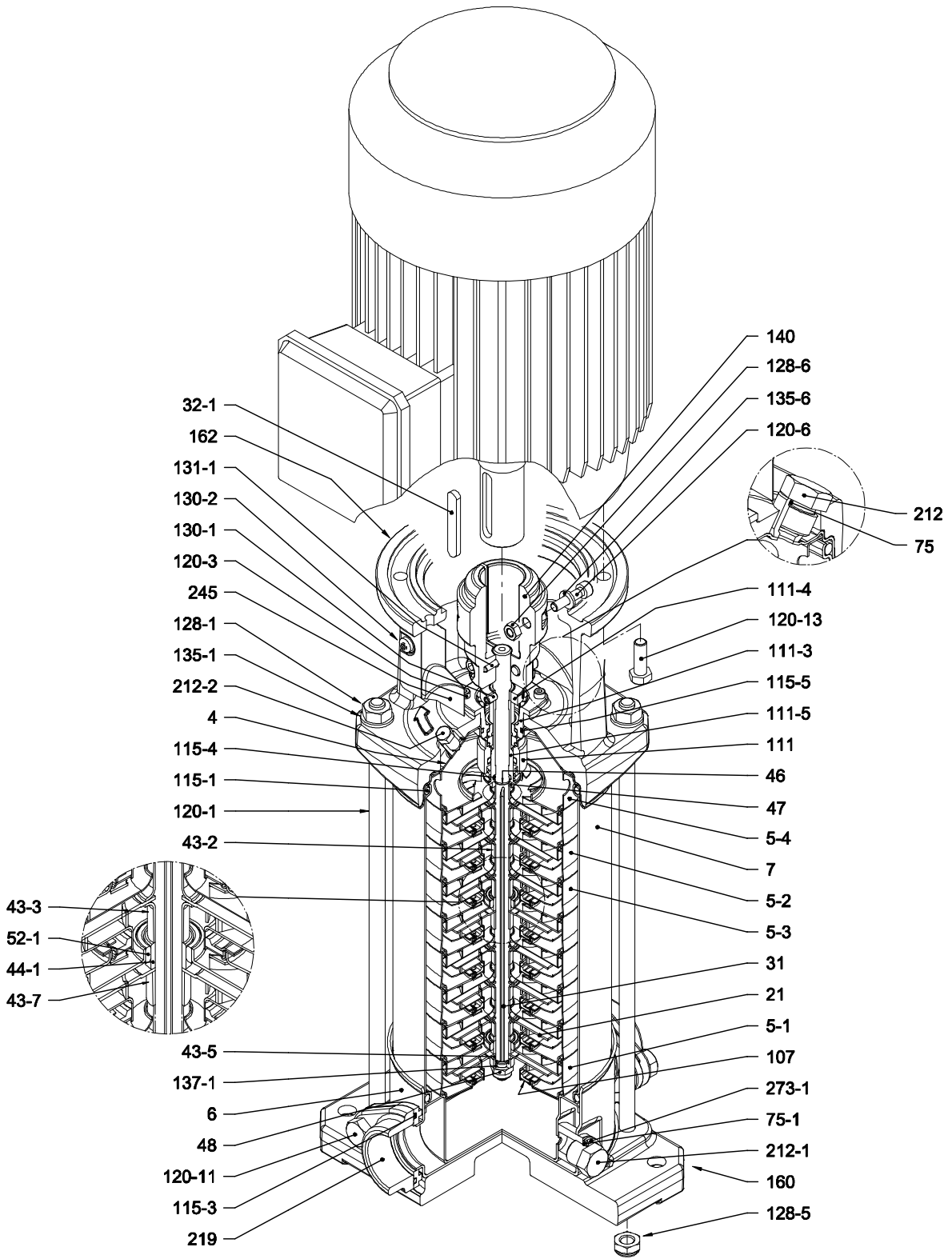

with Oval flange (N)

PIPE CONNECTION EVMS(L)3

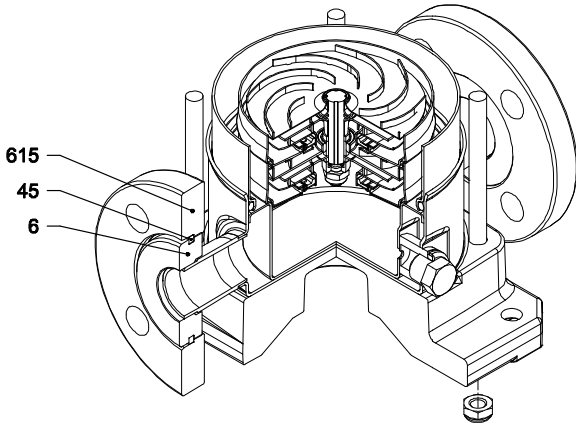

with Loose round flange (LF)

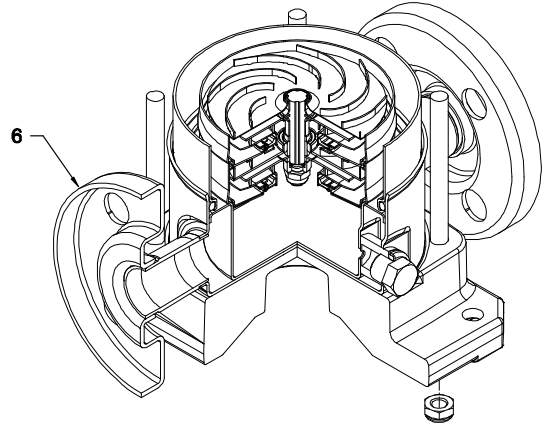

with Round flange (F)

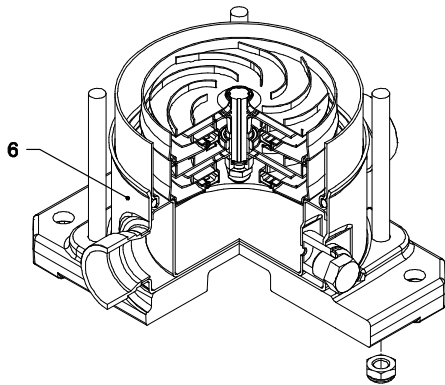

with Victaulic® connection (V)

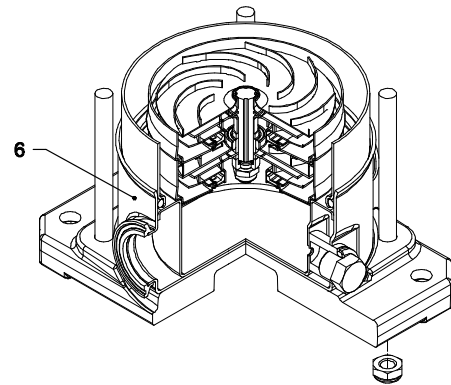

with Clamp connection (C)

SECTIONAL TABLE
EVMS(L)3

N°	PART NAME	MATERIAL		DIMENSIONS	STANDARD
		EVMS	EVMSL		
4	Casing cover	EN 1.4301 (AISI 304)	EN 1.4401 (AISI 316)		
5-1	Suction casing	EN 1.4301 (AISI 304)	EN 1.4401 (AISI 316)		
5-2	Intermediate Casing	EN 1.4301 (AISI 304)	EN 1.4401 (AISI 316)		
5-3	Intermediate casing bearing	EN 1.4301 (AISI 304)	EN 1.4401 (AISI 316)		
5-4	Discharge casing	EN 1.4301 (AISI 304)	EN 1.4401 (AISI 316)		
6	Bottom casing	EN 1.4301 (AISI 304)	EN 1.4401 (AISI 316)		
7	Outer casing	EN 1.4301 (AISI 304)	EN 1.4404 (AISI 316L)		
21	Impeller	EN 1.4301 (AISI 304)	EN 1.4401 (AISI 316)		
31	Shaft	EN 1.4301 (AISI 304)	EN 1.4404 (AISI 316L)		
32-1	Adjuster Key	EN 1.4301 (AISI 304)			
43-2	Shaft sleeve (intermediate)	EN 1.4301 (AISI 304)	EN 1.4404 (AISI 316L)		
43-3	Shaft sleeve (bearing)	EN 1.4301 (AISI 304)	EN 1.4401 (AISI 316)		
43-5	Shaft sleeve (last stage)	EN 1.4301 (AISI 304)	EN 1.4401 (AISI 316)		
43-7	Spacer	EN 1.4301 (AISI 304)	EN 1.4404 (AISI 316L)		
44-1	Shaft sleeve bearing	Tungsten carbide			
45	Flange holder	EN 1.4301 (AISI 304)			
46	Ring (mechanical seal)	EN 1.4404 (AISI 316L)			
47	Ring Holder	EN 1.4301 (AISI 304)	EN 1.4401 (AISI 316)		
48	Impeller nut	A2-70 UNI 7323 with inox insert	A4-70 UNI 7323 with inox insert	M8	
52-1	Bearing	Tungsten carbide			
75	O-Ring (plug)	EPDM		D. 12.37x2.62	OR 3050
75-1	O-Ring (plug)	EPDM			
107	Liner ring	EN 1.4301 (AISI 304) + PPS	EN 1.4401 (AISI 316) + PPS		
111	Mechanical Seal	SiC/Carbon/EPDM			
111-3	Mechanical seal seat	EN 1.4301 (AISI 304)	EN 1.4401 (AISI 316)		
111-4	Seal holder	EN 1.4301 (AISI 304)			
111-5	Mechanical seal cartridge	EN 1.4301 (AISI 304)	EN 1.4401 (AISI 316)		
115-1	O-Ring (outer casing)	EPDM		D. 129.54x5.34	OR 6510
115-3	O-Ring	EPDM			
115-4	O-Ring (cartridge sleeve)	EPDM		D. 11.91x2.62	OR 115
115-5	O-Ring (seal cover)	EPDM		D. 32.99x2.62	OR 3131
120-1	Tie-rod	Galvanized steel 6.8 strength class ISO 898/1		M10	
120-3	Screw	A2-70 UNI 7323		M4x10	ISO 4762
120-6	Screw for coupling	Galvanized steel		M6x25	ISO 4762
120-11	Screw for counterflange	A2-70 UNI 7323			
120-13	Screw for motor	MEC 71-80 MEC 90-100	Galvanized steel 8.8 strength class ISO 898/1	M6x20 M8x20	ISO 4017 ISO 4017
128-1	Nut for tie rod	Galvanized steel		M10	UNI 5588
128-5	Nut for tie rod	A2-70 UNI 7323		M10	UNI 7474
128-6	Nut for coupling	Galvanized steel		M6	ISO 4032
130-1	Set screw	A2-70 UNI 7323		M5x8	UNI 5923
130-2	Screw for coupling guard	A2-70 UNI 7323		M5x6	UNI 7687
131-1	Pin for shaft	Carbon Steel		D. 4x32	UNI 4838
135-1	Washer	Galvanized steel		D. 10.5x21x2	UNI 6592
135-6	Washer	Carbon Steel		Ø6	
137-1	Impeller spacer	EN 1.4301 (AISI 304)	EN 1.4401 (AISI 316)		
140	Coupling	up to 4.0 kW Die cast aluminium EN AB-AISI11Cu2 (Fe)			
160	Base	Die cast aluminium EN AB-AISI11Cu2 (Fe)			
162	Motor bracket	Cast iron EN-GJL-200-EN 1561			
212	Plug	EN 1.4301 (AISI 304)	EN 1.4401 (AISI 316)	G 3/8	
212-1	Plug	EN 1.4301 (AISI 304)	EN 1.4401 (AISI 316)	G 3/8	
212-2	Venting plug	EN 1.4404 (AISI 316L)			
219	Counter flange	EN 1.4301 (AISI 304)	EN 1.4401 (AISI 316)		
245	Coupling guard	EN 1.4301 (AISI 304)			
273-1	Plug Washer	EN 1.4301 (AISI 304)	EN 1.4401 (AISI 316)		
615	Flange	Nodular Cast Iron			

QUANTITY FOR MODEL EVMS(L)3

Pump Type	N°																																
	4	5-1	5-2	5-3	5-4	6	7	21	31	32-1	43-2	43-3	43-5	43-7	44-1	45**	46	47	48	52-1	75	75-1	107	111	111-3	111-4	111-5	115-1	115-3*	115-4	115-5		
EVMS(L)3 2/0.37	1	1	/	1	1	1	1	2	1	1	/	1	/	/	1	4	2	1	1	1	1	2	2	1	1	1	1	2	2	1	1	1	1
EVMS(L)3 3/0.37	1	1	1	1	1	1	1	3	1	1	3	1	/	/	1	4	2	1	1	1	1	2	3	1	1	1	1	1	2	2	1	1	1
EVMS(L)3 4/0.37	1	1	2	1	1	1	1	4	1	1	5	1	/	/	1	4	2	1	1	1	1	2	4	1	1	1	1	1	2	2	1	1	1
EVMS(L)3 5/0.55	1	1	3	1	1	1	1	5	1	1	7	1	1	/	1	4	2	1	1	1	1	2	5	1	1	1	1	1	2	2	1	1	1
EVMS(L)3 6/0.55	1	1	4	1	1	1	1	6	1	1	9	1	/	/	1	4	2	1	1	1	1	2	6	1	1	1	1	1	2	2	1	1	1
EVMS(L)3 7/0.75	1	1	5	1	1	1	1	7	1	1	11	1	/	/	1	4	2	1	1	1	1	2	7	1	1	1	1	1	2	2	1	1	1
EVMS(L)3 8/0.75	1	1	6	1	1	1	1	8	1	1	13	1	/	/	1	4	2	1	1	1	1	2	8	1	1	1	1	1	2	2	1	1	1
EVMS(L)3 9/1.1	1	1	7	1	1	1	1	9	1	1	15	1	1	/	1	4	2	1	1	1	1	2	9	1	1	1	1	1	2	2	1	1	1
EVMS(L)3 10/1.1	1	1	8	1	1	1	1	10	1	1	17	1	/	/	1	4	2	1	1	1	1	2	10	1	1	1	1	1	2	2	1	1	1
EVMS(L)3 11/1.1	1	1	9	1	1	1	1	11	1	1	19	1	/	/	1	4	2	1	1	1	1	2	11	1	1	1	1	1	2	2	1	1	1
EVMS(L)3 12/1.1	1	1	10	1	1	1	1	12	1	1	21	1	/	/	1	4	2	1	1	1	1	2	12	1	1	1	1	1	2	2	1	1	1
EVMS(L)3 13/1.5	1	1	10	2	1	1	1	13	1	1	20	2	1	1	2	4	2	1	1	2	1	2	13	1	1	1	1	1	2	2	1	1	1
EVMS(L)3 14/1.5	1	1	11	2	1	1	1	14	1	1	22	2	/	1	2	4	2	1	1	2	1	2	14	1	1	1	1	1	2	2	1	1	1
EVMS(L)3 15/1.5	1	1	12	2	1	1	1	15	1	1	24	2	/	1	2	4	2	1	1	2	1	2	15	1	1	1	1	1	2	2	1	1	1
EVMS(L)3 16/1.5	1	1	13	2	1	1	1	16	1	1	26	2	/	1	2	4	2	1	1	2	1	2	16	1	1	1	1	1	2	2	1	1	1
EVMS(L)3 17/2.2	1	1	14	2	1	1	1	17	1	1	28	2	1	1	2	4	2	1	1	2	1	2	17	1	1	1	1	1	2	2	1	1	1
EVMS(L)3 19/2.2	1	1	16	2	1	1	1	19	1	1	32	2	/	1	2	4	2	1	1	2	1	2	19	1	1	1	1	1	2	2	1	1	1
EVMS(L)3 21/2.2	1	1	18	2	1	1	1	21	1	1	36	2	1	1	2	4	2	1	1	2	1	2	21	1	1	1	1	1	2	2	1	1	1
EVMS(L)3 23/2.2	1	1	20	2	1	1	1	23	1	1	40	2	/	1	2	4	2	1	1	2	1	2	23	1	1	1	1	1	2	/	1	1	1
EVMS(L)3 24/2.2	1	1	21	2	1	1	1	24	1	1	42	2	/	1	2	4	2	1	1	2	1	2	24	1	1	1	1	1	2	/	1	1	1
EVMS(L)3 25/3.0	1	1	22	2	1	1	1	25	1	1	44	2	/	1	2	4	2	1	1	2	1	2	25	1	1	1	1	1	2	/	1	1	1
EVMS(L)3 27/3.0	1	1	24	2	1	1	1	27	1	1	48	2	/	1	2	4	2	1	1	2	1	2	27	1	1	1	1	1	2	/	1	1	1
EVMS(L)3 29/3.0	1	1	26	2	1	1	1	29	1	1	52	2	/	1	2	4	2	1	1	2	1	2	29	1	1	1	1	1	2	/	1	1	1
EVMS(L)3 31/3.0	1	1	28	2	1	1	1	31	1	1	56	2	/	1	2	4	2	1	1	2	1	2	31	1	1	1	1	1	2	/	1	1	1
EVMS(L)3 33/3.0	1	1	30	2	1	1	1	33	1	1	60	2	/	1	2	4	2	1	1	2	1	2	33	1	1	1	1	1	2	/	1	1	1

Pump Type	N°																							
	120-1	120-3	120-6	120-11*	120-13	128-1	128-5	128-6	130-1	130-2	131-1	135-1	135-6	137-1	140	160	162	212	212-1	212-2	219*	245	273-1	615**
EVMS(L)3 2/0.37	4	4	4	4	4	4	4	4	3	4	1	4	4	1	2	1	1	1	2	1	2	2	2	2
EVMS(L)3 3/0.37	4	4	4	4	4	4	4	4	3	4	1	4	4	1	2	1	1	1	2	1	2	2	2	2
EVMS(L)3 4/0.37	4	4	4	4	4	4	4	4	3	4	1	4	4	1	2	1	1	1	2	1	2	2	2	2
EVMS(L)3 5/0.55	4	4	4	4	4	4	4	4	3	4	1	4	4	1	2	1	1	1	2	1	2	2	2	2
EVMS(L)3 6/0.55	4	4	4	4	4	4	4	4	3	4	1	4	4	1	2	1	1	1	2	1	2	2	2	2
EVMS(L)3 7/0.75	4	4	4	4	4	4	4	4	3	4	1	4	4	1	2	1	1	1	2	1	2	2	2	2
EVMS(L)3 8/0.75	4	4	4	4	4	4	4	4	3	4	1	4	4	1	2	1	1	1	2	1	2	2	2	2
EVMS(L)3 9/1.1	4	4	4	4	4	4	4	4	3	4	1	4	4	1	2	1	1	1	2	1	2	2	2	2
EVMS(L)3 10/1.1	4	4	4	4	4	4	4	4	3	4	1	4	4	1	2	1	1	1	2	1	2	2	2	2
EVMS(L)3 11/1.1	4	4	4	4	4	4	4	4	3	4	1	4	4	1	2	1	1	1	2	1	2	2	2	2
EVMS(L)3 12/1.1	4	4	4	4	4	4	4	4	3	4	1	4	4	1	2	1	1	1	2	1	2	2	2	2
EVMS(L)3 13/1.5	4	4	4	4	4	4	4	4	3	4	1	4	4	1	2	1	1	1	2	1	2	2	2	2
EVMS(L)3 14/1.5	4	4	4	4	4	4	4	4	3	4	1	4	4	1	2	1	1	1	2	1	2	2	2	2
EVMS(L)3 15/1.5	4	4	4	4	4	4	4	4	3	4	1	4	4	1	2	1	1	1	2	1	2	2	2	2
EVMS(L)3 16/1.5	4	4	4	4	4	4	4	4	3	4	1	4	4	1	2	1	1	1	2	1	2	2	2	2
EVMS(L)3 17/2.2	4	4	4	4	4	4	4	4	3	4	1	4	4	1	2	1	1	1	2	1	2	2	2	2
EVMS(L)3 19/2.2	4	4	4	4	4	4	4	4	3	4	1	4	4	1	2	1	1	1	2	1	2	2	2	2
EVMS(L)3 21/2.2	4	4	4	4	4	4	4	4	3	4	1	4	4	1	2	1	1	1	2	1	2	2	2	2
EVMS(L)3 23/2.2	4	4	4	/	4	4	4	4	3	4	1	4	4	1	2	1	1	1	2	1	/	2	2	2
EVMS(L)3 24/2.2	4	4	4	/	4	4	4	4	3	4	1	4	4	1	2	1	1	1	2	1	/	2	2	2
EVMS(L)3 25/3.0	4	4	4	/	4	4	4	4	3	4	1	4	4	1	2	1	1	1	2	1	/	2	2	2
EVMS(L)3 27/3.0	4	4	4	/	4	4	4	4	3	4	1	4	4	1	2	1	1	1	2	1	/	2	2	2
EVMS(L)3 29/3.0	4	4	4	/	4	4	4	4	3	4	1	4	4	1	2	1	1	1	2	1	/	2	2	2
EVMS(L)3 31/3.0	4	4	4	/	4	4	4	4	3	4	1	4	4	1	2	1	1	1	2	1	/	2	2	2
EVMS(L)3 33/3.0	4	4	4	/	4	4	4	4	3	4	1	4	4	1	2	1	1	1	2	1	/	2	2	2

* only for Oval flange (N)

** only for Loose round flange (LF)

PERFORMANCE CURVE
EVMSG3

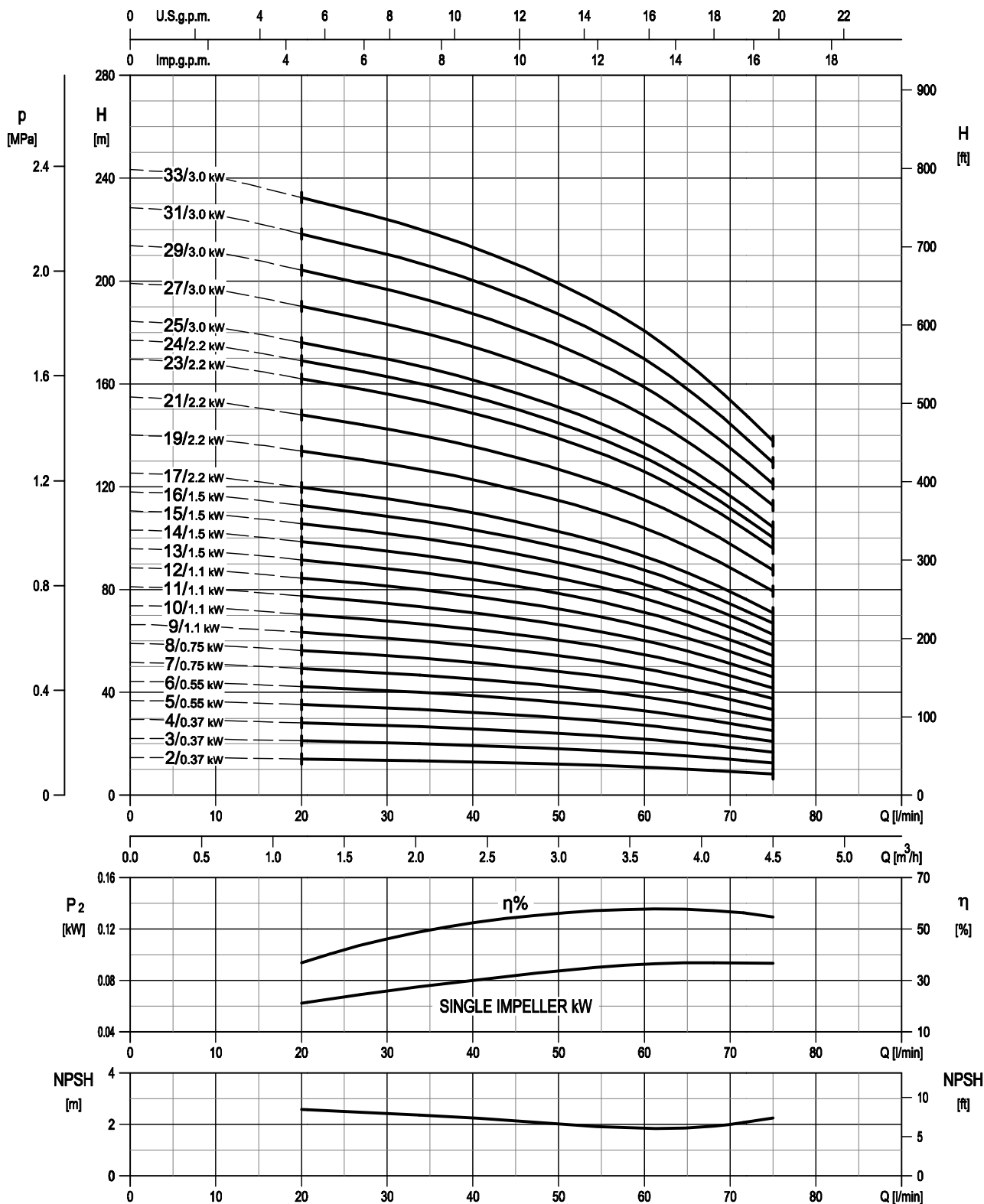

Rotation speed $\approx 2900 \text{ min}^{-1}$
Test standard: ISO 9906:2012 - Grade 3B

TECHNICAL DATA EVMSG3

Dimensional sketch

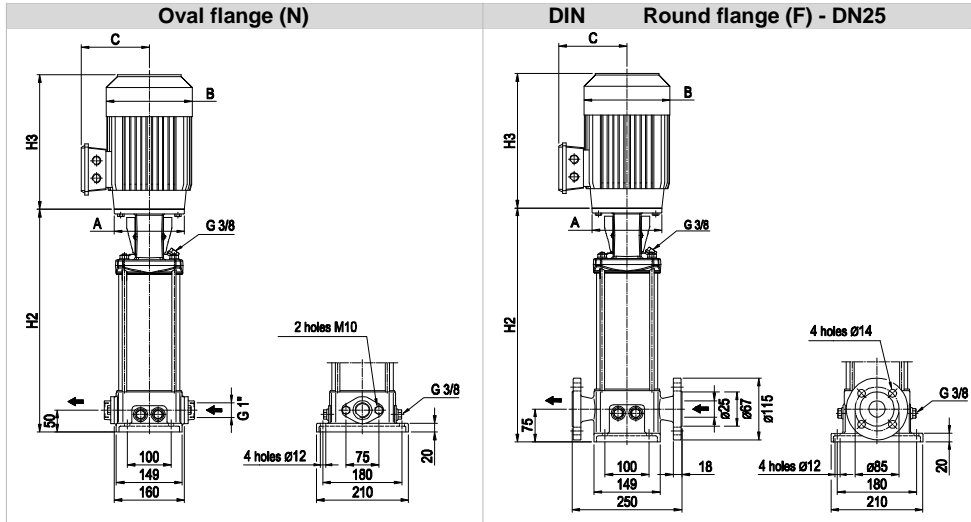

Dimensions [mm] and Weights [Kg]

Pump Type	Pmax [MPa]	kW	Size	Motor									Oval flange (N)			Round flange (F)		
				1 ~			3 ~			H2	Weight Pump	Weight Pump + Motor		H2	Weight Pump	Weight Pump + Motor		
				A	B	C	H3	B	C			H3	1 ~			3 ~	1 ~	3 ~
EVMSG3 2/0.37	1.6	0.37	71	ø105	139	133	216	139	114	216	250	12.9	20	18.7	275	15.7	22.8	21.5
EVMSG3 3/0.37	1.6	0.37	71	ø105	139	133	216	139	114	216	271	13.3	20.4	19.1	296	16.1	23.2	21.9
EVMSG3 4/0.37	1.6	0.37	71	ø105	139	133	216	139	114	216	292	13.8	20.9	19.6	317	16.6	23.7	22.4
EVMSG3 5/0.55	1.6	0.55	71	ø105	139	133	216	139	114	216	313	14.2	22.7	20.4	338	17	25.5	23.2
EVMSG3 6/0.55	1.6	0.55	71	ø105	139	133	216	139	114	216	334	14.7	23.2	20.9	359	17.4	25.9	23.6
EVMSG3 7/0.75	1.6	0.75	80	ø120	160	151	232	160	139	232	365	15.6	27	25.1	390	18.3	29.7	27.8
EVMSG3 8/0.75	1.6	0.75	80	ø120	160	151	232	160	139	232	386	16	27.4	25.5	411	18.8	30.2	28.3
EVMSG3 9/1.1	1.6	1.1	80	ø120	160	151	232	160	139	232	407	16.4	28.2	27.5	432	19.2	31	30.3
EVMSG3 10/1.1	1.6	1.1	80	ø120	160	151	232	160	139	232	428	16.9	28.7	28	453	19.7	31.5	30.8
EVMSG3 11/1.1	1.6	1.1	80	ø120	160	151	232	160	139	232	449	17.3	29.1	28.4	474	20.1	31.9	31.2
EVMSG3 12/1.1	1.6	1.1	80	ø120	160	151	232	160	139	232	470	17.8	29.6	28.9	495	20.6	32.4	31.7
EVMSG3 13/1.5	1.6	1.5	90 S	ø140	172	140	278	180	148	267	501	18.5	36.3	32.5	526	21.3	39.1	35.3
EVMSG3 14/1.5	1.6	1.5	90 S	ø140	172	140	278	180	148	267	522	19	36.8	31.7	547	21.7	39.5	34.4
EVMSG3 15/1.5	1.6	1.5	90 S	ø140	172	140	278	180	148	267	543	19.4	37.2	32.1	568	22.2	40	34.9
EVMSG3 16/1.5	1.6	1.5	90 S	ø140	172	140	278	180	148	267	564	20.5	38.3	33.2	589	23.2	41	35.9
EVMSG3 17/2.2	1.6	2.2	90 L	ø140	172	140	278	180	148	267	585	20.9	40.4	36.9	610	23.7	43.2	39.7
EVMSG3 19/2.2	1.6	2.2	90 L	ø140	172	140	278	180	148	267	627	21.9	41.4	37.9	652	24.7	44.2	40.7
EVMSG3 21/2.2	1.6	2.2	90 L	ø140	172	140	278	180	148	267	669	22.8	42.3	38.8	694	25.6	45.1	41.6
EVMSG3 23/2.2	2.5	2.2	90 L	ø140	172	140	278	180	148	267	-	-	-	-	736	26.6	46.1	42.6
EVMSG3 24/2.2	2.5	2.2	90 L	ø140	172	140	278	180	148	267	-	-	-	-	757	27	46.5	43
EVMSG3 25/3.0	2.5	3.0	100 L	ø160	-	-	-	196	155	306	-	-	-	-	788	27.6	-	50.4
EVMSG3 27/3.0	2.5	3.0	100 L	ø160	-	-	-	196	155	306	-	-	-	-	830	28.6	-	51.4
EVMSG3 29/3.0	2.5	3.0	100 L	ø160	-	-	-	196	155	306	-	-	-	-	872	29.6	-	52.4
EVMSG3 31/3.0	2.5	3.0	100 L	ø160	-	-	-	196	155	306	-	-	-	-	914	30.5	-	53.3
EVMSG3 33/3.0	2.5	3.0	100 L	ø160	-	-	-	196	155	306	-	-	-	-	956	31.3	-	54.1

1.6 MPa=16 bar ; 2.5 MPa=25 bar
- not available model

SECTIONAL VIEW
EVMSG3

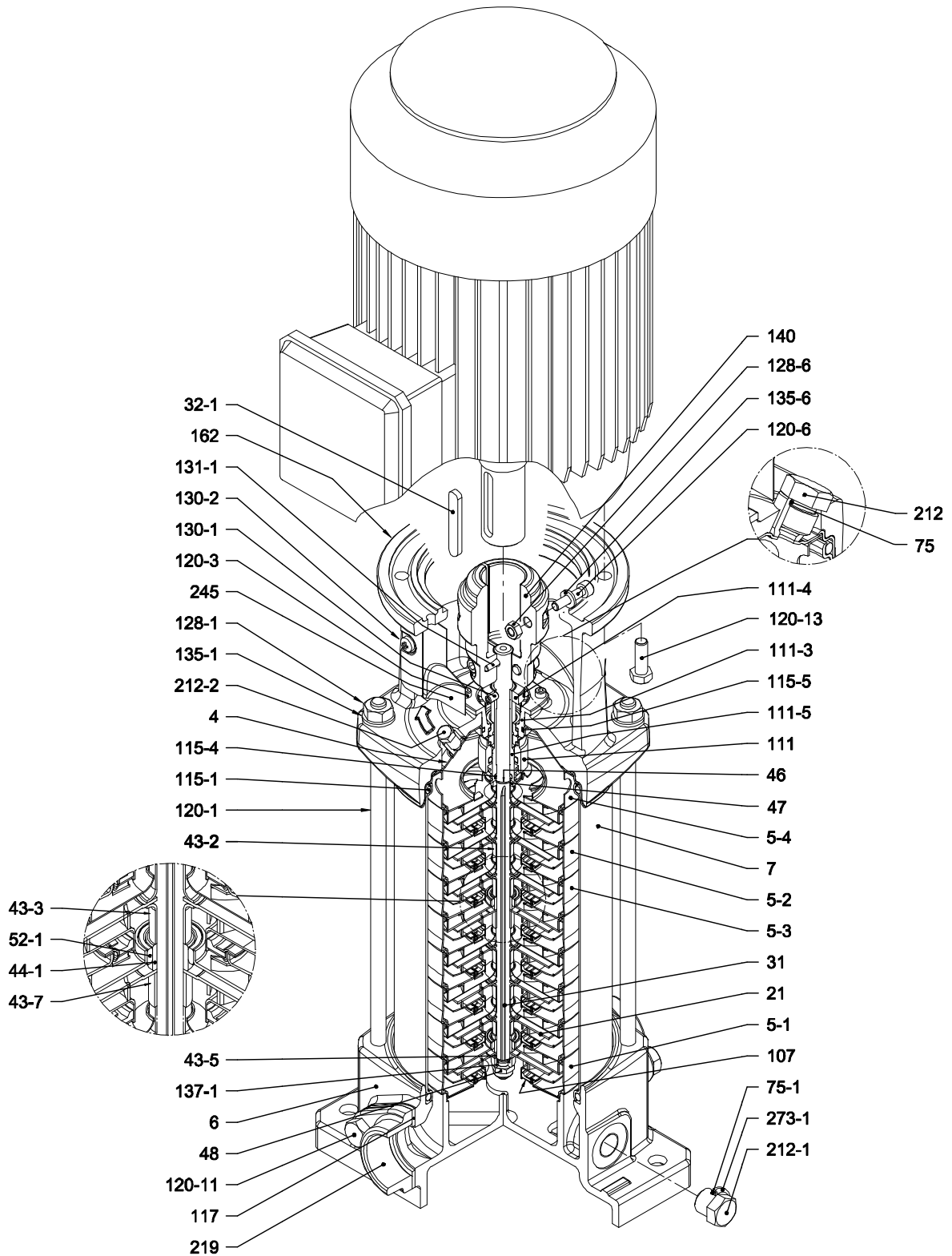

with Oval flange (N)

PIPE CONNECTION EVMSG3

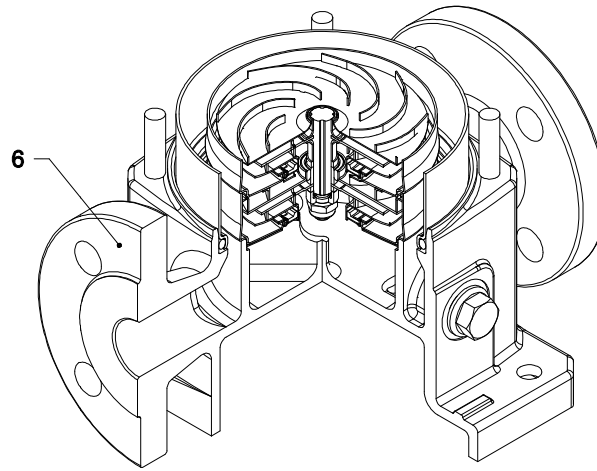

with Round flange (F)

SECTIONAL TABLE
EVMSG3

N°	PART NAME	MATERIAL EVMSG	DIMENSIONS	STANDARD	
4	Casing cover	EN 1.4301 (AISI 304)			
5-1	Suction casing	EN 1.4301 (AISI 304)			
5-2	Intermediate Casing	EN 1.4301 (AISI 304)			
5-3	Intermediate casing bearing	EN 1.4301 (AISI 304)			
5-4	Discharge casing	EN 1.4301 (AISI 304)			
6	Bottom casing	Cast Iron EN G.JL-250-EN1561			
7	Outer casing	EN 1.4301 (AISI 304)			
21	Impeller	EN 1.4301 (AISI 304)			
31	Shaft	EN 1.4301 (AISI 304)			
32-1	Adjuster Key	EN 1.4301 (AISI 304)			
43-2	Shaft sleeve (intermediate)	EN 1.4301 (AISI 304)			
43-3	Shaft sleeve (bearing)	EN 1.4301 (AISI 304)			
43-5	Shaft sleeve (last stage)	EN 1.4301 (AISI 304)			
43-7	Spacer	EN 1.4301 (AISI 304)			
44-1	Shaft sleeve bearing	Tungsten carbide			
46	Ring (mechanical seal)	EN 1.4404 (AISI 316L)			
47	Ring Holder	EN 1.4301 (AISI 304)			
48	Impeller nut	A2-70 UNI 7323 with inox insert	M8		
52-1	Bearing	Tungsten carbide			
75	O-Ring (plug)	EPDM	D. 12.37x2.62	OR 3050	
75-1	O-Ring (plug)	EPDM			
107	Liner ring	EN 1.4301 (AISI 304) + PPS			
111	Mechanical Seal	SiC/Carbon/EPDM			
111-3	Mechanical seal seat	EN 1.4301 (AISI 304)			
111-4	Seal holder	EN 1.4301 (AISI 304)			
111-5	Mechanical seal cartridge	EN 1.4301 (AISI 304)			
115-1	O-Ring (outer casing)	EPDM	D. 129.54x5.34	OR 6510	
115-4	O-Ring (cartridge sleeve)	EPDM	D. 11.91x2.62	OR 115	
115-5	O-Ring (seal cover)	EPDM	D. 32.99x2.62	OR 3131	
117	Flange gasket	EPDM			
120-1	Tie-rod	Galvanized steel 6.8 strength class ISO 898/1	M10		
120-3	Screw	A2-70 UNI 7323	M4x10	ISO 4762	
120-6	Screw for coupling	Galvanized steel	M6x25	ISO 4762	
120-11	Screw for counterflange	A2-70 UNI 7323			
120-13	Screw for motor	MEC 71-80	Galvanized steel 8.8 strength class ISO 898/1	M6x20	ISO 4017
		MEC 90-100		M8x20	ISO 4017
128-1	Nut for tie rod	Galvanized steel	M10	UNI 5588	
128-6	Nut for coupling	Galvanized steel	M6	ISO 4032	
130-1	Set screw	A2-70 UNI 7323	M5x8	UNI 5923	
130-2	Screw for coupling guard	A2-70 UNI 7323	M5x6	UNI 7687	
131-1	Pin for shaft	Carbon Steel	D. 4x32	UNI 4838	
135-1	Washer	Galvanized steel	D. 10.5x21x2	UNI 6592	
135-6	Washer	Carbon Steel	Ø6		
137-1	Impeller spacer	EN 1.4301 (AISI 304)			
140	Coupling	up to 4.0 kW	Die cast Aluminium EN AB-AISI11Cu2 (Fe)		
162	Motor bracket	Cast iron EN-G.JL-200-EN 1561			
212	Plug	EN 1.4301 (AISI 304)	G 3/8		
212-1	Plug	EN 1.4301 (AISI 304)	G 3/8		
212-2	Venting plug	EN 1.4404 (AISI 316L)			
219	Counter flange	Galvanized steel			
245	Coupling guard	EN 1.4301 (AISI 304)			
273-1	Plug Washer	EN 1.4301 (AISI 304)			

QUANTITY FOR MODEL EVMSG3

Pump Type	N°																												
	4	5-1	5-2	5-3	5-4	6	7	21	31	32-1	43-2	43-3	43-5	43-7	44-1	46	47	48	52-1	75	75-1	107	111	111-3	111-4	111-5	115-1	115-4	115-5
EVMSG3 2/0.37	1	1	/	1	1	1	1	2	1	1	/	1	/	/	1	2	1	1	1	1	4	2	1	1	1	1	2	1	1
EVMSG3 3/0.37	1	1	1	1	1	1	1	3	1	1	3	1	/	/	1	2	1	1	1	1	4	3	1	1	1	1	2	1	1
EVMSG3 4/0.37	1	1	2	1	1	1	1	4	1	1	5	1	/	/	1	2	1	1	1	1	4	4	1	1	1	1	2	1	1
EVMSG3 5/0.55	1	1	3	1	1	1	1	5	1	1	7	1	1	/	1	2	1	1	1	1	4	5	1	1	1	1	2	1	1
EVMSG3 6/0.55	1	1	4	1	1	1	1	6	1	1	9	1	/	/	1	2	1	1	1	1	4	6	1	1	1	1	2	1	1
EVMSG3 7/0.75	1	1	5	1	1	1	1	7	1	1	11	1	/	/	1	2	1	1	1	1	4	7	1	1	1	1	2	1	1
EVMSG3 8/0.75	1	1	6	1	1	1	1	8	1	1	13	1	/	/	1	2	1	1	1	1	4	8	1	1	1	1	2	1	1
EVMSG3 9/1.1	1	1	7	1	1	1	1	9	1	1	15	1	1	/	1	2	1	1	1	1	4	9	1	1	1	1	2	1	1
EVMSG3 10/1.1	1	1	8	1	1	1	1	10	1	1	17	1	/	/	1	2	1	1	1	1	4	10	1	1	1	1	2	1	1
EVMSG3 11/1.1	1	1	9	1	1	1	1	11	1	1	19	1	/	/	1	2	1	1	1	1	4	11	1	1	1	1	2	1	1
EVMSG3 12/1.1	1	1	10	1	1	1	1	12	1	1	21	1	/	/	1	2	1	1	1	1	4	12	1	1	1	1	2	1	1
EVMSG3 13/1.5	1	1	10	2	1	1	1	13	1	1	20	2	1	1	2	2	1	1	2	1	4	13	1	1	1	1	2	1	1
EVMSG3 14/1.5	1	1	11	2	1	1	1	14	1	1	22	2	/	1	2	2	1	1	2	1	4	14	1	1	1	1	2	1	1
EVMSG3 15/1.5	1	1	12	2	1	1	1	15	1	1	24	2	/	1	2	2	1	1	2	1	4	15	1	1	1	1	2	1	1
EVMSG3 16/1.5	1	1	13	2	1	1	1	16	1	1	26	2	/	1	2	2	1	1	2	1	4	16	1	1	1	1	2	1	1
EVMSG3 17/2.2	1	1	14	2	1	1	1	17	1	1	28	2	1	1	2	2	1	1	2	1	4	17	1	1	1	1	2	1	1
EVMSG3 19/2.2	1	1	16	2	1	1	1	19	1	1	32	2	/	1	2	2	1	1	2	1	4	19	1	1	1	1	2	1	1
EVMSG3 21/2.2	1	1	18	2	1	1	1	21	1	1	36	2	1	1	2	2	1	1	2	1	4	21	1	1	1	1	2	1	1
EVMSG3 23/2.2	1	1	20	2	1	1	1	23	1	1	40	2	/	1	2	2	1	1	2	1	4	23	1	1	1	1	2	1	1
EVMSG3 24/2.2	1	1	21	2	1	1	1	24	1	1	42	2	/	1	2	2	1	1	2	1	4	24	1	1	1	1	2	1	1
EVMSG3 25/3.0	1	1	22	2	1	1	1	25	1	1	44	2	/	1	2	2	1	1	2	1	4	25	1	1	1	1	2	1	1
EVMSG3 27/3.0	1	1	24	2	1	1	1	27	1	1	48	2	/	1	2	2	1	1	2	1	4	27	1	1	1	1	2	1	1
EVMSG3 29/3.0	1	1	26	2	1	1	1	29	1	1	52	2	/	1	2	2	1	1	2	1	4	29	1	1	1	1	2	1	1
EVMSG3 31/3.0	1	1	28	2	1	1	1	31	1	1	56	2	/	1	2	2	1	1	2	1	4	31	1	1	1	1	2	1	1
EVMSG3 33/3.0	1	1	30	2	1	1	1	33	1	1	60	2	/	1	2	2	1	1	2	1	4	33	1	1	1	1	2	1	1

Pump Type	N°																					
	117*	120-1	120-3	120-6	120-11*	120-13	128-1	128-6	130-1	130-2	131-1	135-1	135-6	137-1	140	162	212	212-1	212-2	219*	245	273-1
EVMSG3 2/0.37	2	4	4	4	4	4	4	4	3	4	1	4	4	1	2	1	1	4	1	2	2	4
EVMSG3 3/0.37	2	4	4	4	4	4	4	4	3	4	1	4	4	1	2	1	1	4	1	2	2	4
EVMSG3 4/0.37	2	4	4	4	4	4	4	4	3	4	1	4	4	1	2	1	1	4	1	2	2	4
EVMSG3 5/0.55	2	4	4	4	4	4	4	4	3	4	1	4	4	1	2	1	1	4	1	2	2	4
EVMSG3 6/0.55	2	4	4	4	4	4	4	4	3	4	1	4	4	1	2	1	1	4	1	2	2	4
EVMSG3 7/0.75	2	4	4	4	4	4	4	4	3	4	1	4	4	1	2	1	1	4	1	2	2	4
EVMSG3 8/0.75	2	4	4	4	4	4	4	4	3	4	1	4	4	1	2	1	1	4	1	2	2	4
EVMSG3 9/1.1	2	4	4	4	4	4	4	4	3	4	1	4	4	1	2	1	1	4	1	2	2	4
EVMSG3 10/1.1	2	4	4	4	4	4	4	4	3	4	1	4	4	1	2	1	1	4	1	2	2	4
EVMSG3 11/1.1	2	4	4	4	4	4	4	4	3	4	1	4	4	1	2	1	1	4	1	2	2	4
EVMSG3 12/1.1	2	4	4	4	4	4	4	4	3	4	1	4	4	1	2	1	1	4	1	2	2	4
EVMSG3 13/1.5	2	4	4	4	4	4	4	4	3	4	1	4	4	1	2	1	1	4	1	2	2	4
EVMSG3 14/1.5	2	4	4	4	4	4	4	4	3	4	1	4	4	1	2	1	1	4	1	2	2	4
EVMSG3 15/1.5	2	4	4	4	4	4	4	4	3	4	1	4	4	1	2	1	1	4	1	2	2	4
EVMSG3 16/1.5	2	4	4	4	4	4	4	4	3	4	1	4	4	1	2	1	1	4	1	2	2	4
EVMSG3 17/2.2	2	4	4	4	4	4	4	4	3	4	1	4	4	1	2	1	1	4	1	2	2	4
EVMSG3 19/2.2	2	4	4	4	4	4	4	4	3	4	1	4	4	1	2	1	1	4	1	2	2	4
EVMSG3 21/2.2	2	4	4	4	4	4	4	4	3	4	1	4	4	1	2	1	1	4	1	2	2	4
EVMSG3 23/2.2	/	4	4	4	/	4	4	4	3	4	1	4	4	1	2	1	1	4	1	/	2	4
EVMSG3 24/2.2	/	4	4	4	/	4	4	4	3	4	1	4	4	1	2	1	1	4	1	/	2	4
EVMSG3 25/3.0	/	4	4	4	/	4	4	4	3	4	1	4	4	1	2	1	1	4	1	/	2	4
EVMSG3 27/3.0	/	4	4	4	/	4	4	4	3	4	1	4	4	1	2	1	1	4	1	/	2	4
EVMSG3 29/3.0	/	4	4	4	/	4	4	4	3	4	1	4	4	1	2	1	1	4	1	/	2	4
EVMSG3 31/3.0	/	4	4	4	/	4	4	4	3	4	1	4	4	1	2	1	1	4	1	/	2	4
EVMSG3 33/3.0	/	4	4	4	/	4	4	4	3	4	1	4	4	1	2	1	1	4	1	/	2	4

* only for Oval flange (N)

PERFORMANCE CURVE
EVMS(L)5

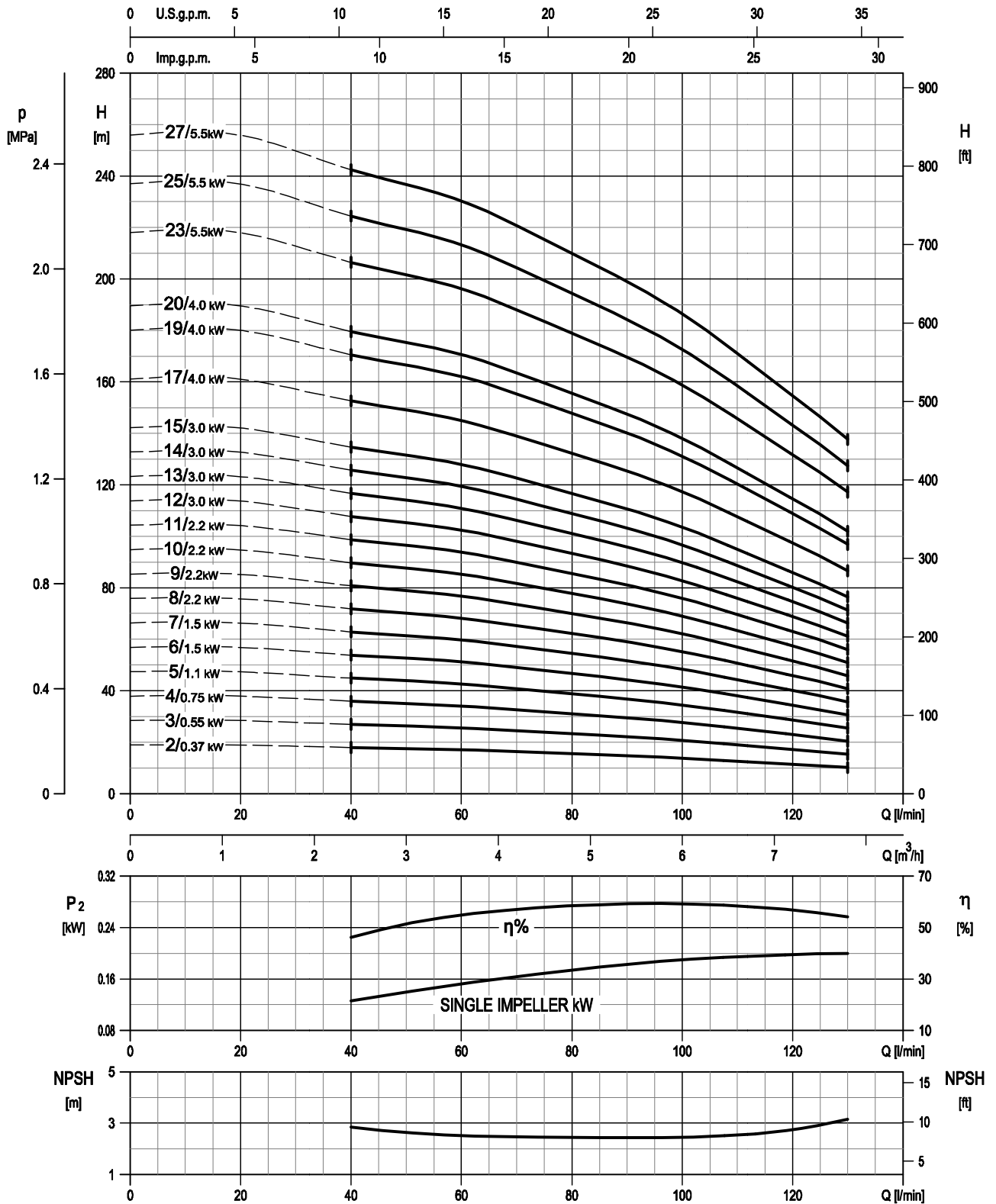

Rotation speed $\approx 2900 \text{ min}^{-1}$
Test standard: ISO 9906:2012 - Grade 3B

TECHNICAL DATA EVMS(L)5

Dimensional sketch

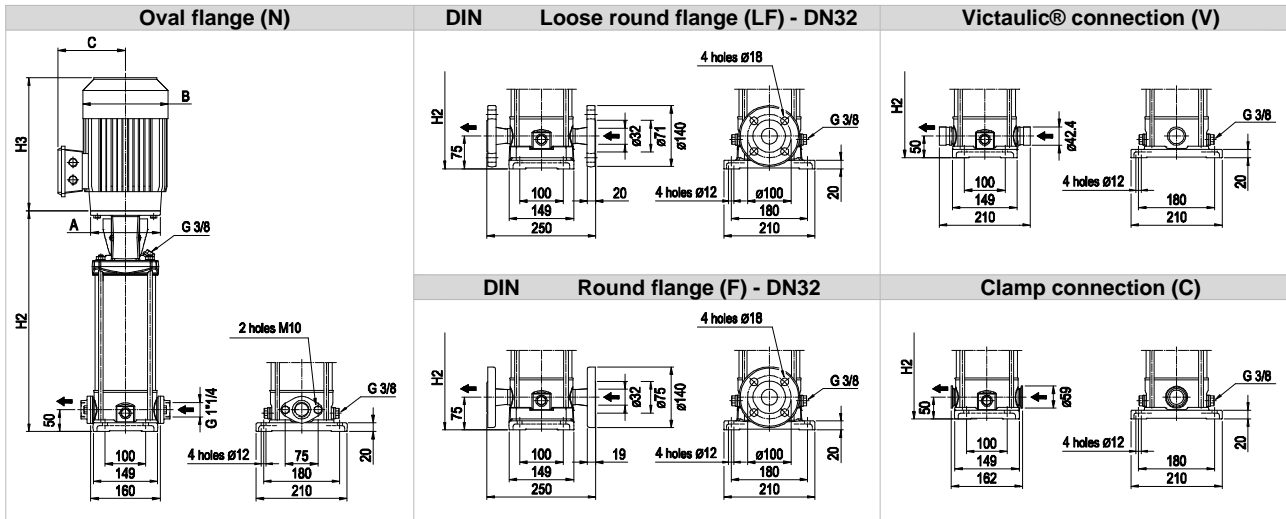

Dimensions [mm] and Weights [Kg]

Pump Type	Pmax [MPa]	kW	Motor			Oval flange (N)		Loose round flange (LF) Round flange (F)			Victaulic® connection (V) Clamp connection (C)											
			Size	A	1 -	3 -	H2	Weight Pump	Weight Pump + Motor	H2	Weight Pump	Weight Pump + Motor	H2	Weight Pump	Weight Pump + Motor							
EVMS(L)5 2/0.37	1.6	0.37	71	Ø105	139	133	216	139	114	216	264	9.8	16.9	15.6	289	11	18.1	16.8	264	9.9	17	15.7
EVMS(L)5 3/0.55	1.6	0.55	71	Ø105	139	133	216	139	114	216	292	10.3	18.8	16.5	317	11.5	20	17.7	292	10.4	18.9	16.6
EVMS(L)5 4/0.75	1.6	0.75	80	Ø120	160	151	232	160	139	232	330	11.3	22.7	20.8	355	12.5	23.9	22	330	11.4	22.8	20.9
EVMS(L)5 5/1.1	1.6	1.1	80	Ø120	160	151	232	160	139	232	358	11.8	23.6	22.9	383	13	24.8	24.1	358	11.9	23.7	23
EVMS(L)5 6/1.5	1.6	1.5	90 S	Ø140	172	140	278	180	148	267	396	12.7	30.5	25.4	421	13.7	31.5	26.4	396	12.6	30.4	25.3
EVMS(L)5 7/1.5	1.6	1.5	90 S	Ø140	172	140	278	180	148	267	424	12.8	30.6	25.5	449	14.1	31.9	26.8	424	13	30.8	25.7
EVMS(L)5 8/2.2	1.6	2.2	90 L	Ø140	172	140	278	180	148	267	452	13.4	32.9	29.4	477	14.6	34.1	30.6	452	13.5	33	29.5
EVMS(L)5 9/2.2	1.6	2.2	90 L	Ø140	172	140	278	180	148	267	480	13.9	33.4	29.9	505	15.2	34.7	31.2	480	14.1	33.6	30.1
EVMS(L)5 10/2.2	1.6	2.2	90 L	Ø140	172	140	278	180	148	267	508	14.4	33.9	30.4	533	15.6	35.1	31.6	508	14.5	34	30.5
EVMS(L)5 11/2.2	1.6	2.2	90 L	Ø140	172	140	278	180	148	267	536	15.2	34.7	31.2	561	16.5	36	32.5	536	15.4	34.9	31.4
EVMS(L)5 12/3.0	1.6	3.0	100 L	Ø160	-	-	-	196	155	306	574	16.7	-	39.5	599	17.7	-	40.5	574	16.6	-	39.4
EVMS(L)5 13/3.0	1.6	3.0	100 L	Ø160	-	-	-	196	155	306	602	17	-	39.8	627	18.3	-	41.1	602	17.2	-	40
EVMS(L)5 14/3.0	1.6	3.0	100 L	Ø160	-	-	-	196	155	306	630	17.6	-	40.4	655	18.8	-	41.6	630	17.7	-	40.5
EVMS(L)5 15/3.0	1.6	3.0	100 L	Ø160	-	-	-	196	155	306	658	18.6	-	41.4	683	19.9	-	42.7	658	18.8	-	41.6
EVMS(L)5 17/4.0	1.6	4.0	112 M	Ø160	-	-	-	196	155	306	714	19.3	-	45.8	739	20.6	-	47.1	714	19.5	-	46
EVMS(L)5 19/4.0	2.5	4.0	112 M	Ø160	-	-	-	196	155	306	-	-	-	795	21.7	-	48.2	770	20.6	-	47.1	
EVMS(L)5 20/4.0	2.5	4.0	112 M	Ø160	-	-	-	196	155	306	-	-	-	823	23.9	-	50.4	798	22.8	-	49.3	
EVMS(L)5 23/5.5	2.5	5.5	132 S	Ø300	-	-	-	225	160	328	-	-	-	1001	30.6	-	69.2	976	29.5	-	68.1	
EVMS(L)5 25/5.5	2.5	5.5	132 S	Ø300	-	-	-	225	160	328	-	-	-	1057	31.6	-	70.2	1032	30.5	-	69.1	
EVMS(L)5 27/5.5	2.5	5.5	132 S	Ø300	-	-	-	225	160	328	-	-	-	1113	33.1	-	71.7	1088	32	-	70.6	

1.6 MPa=16 bar ; 2.5 MPa=25 bar
- not available model

SECTIONAL VIEW
EVMS(L)5

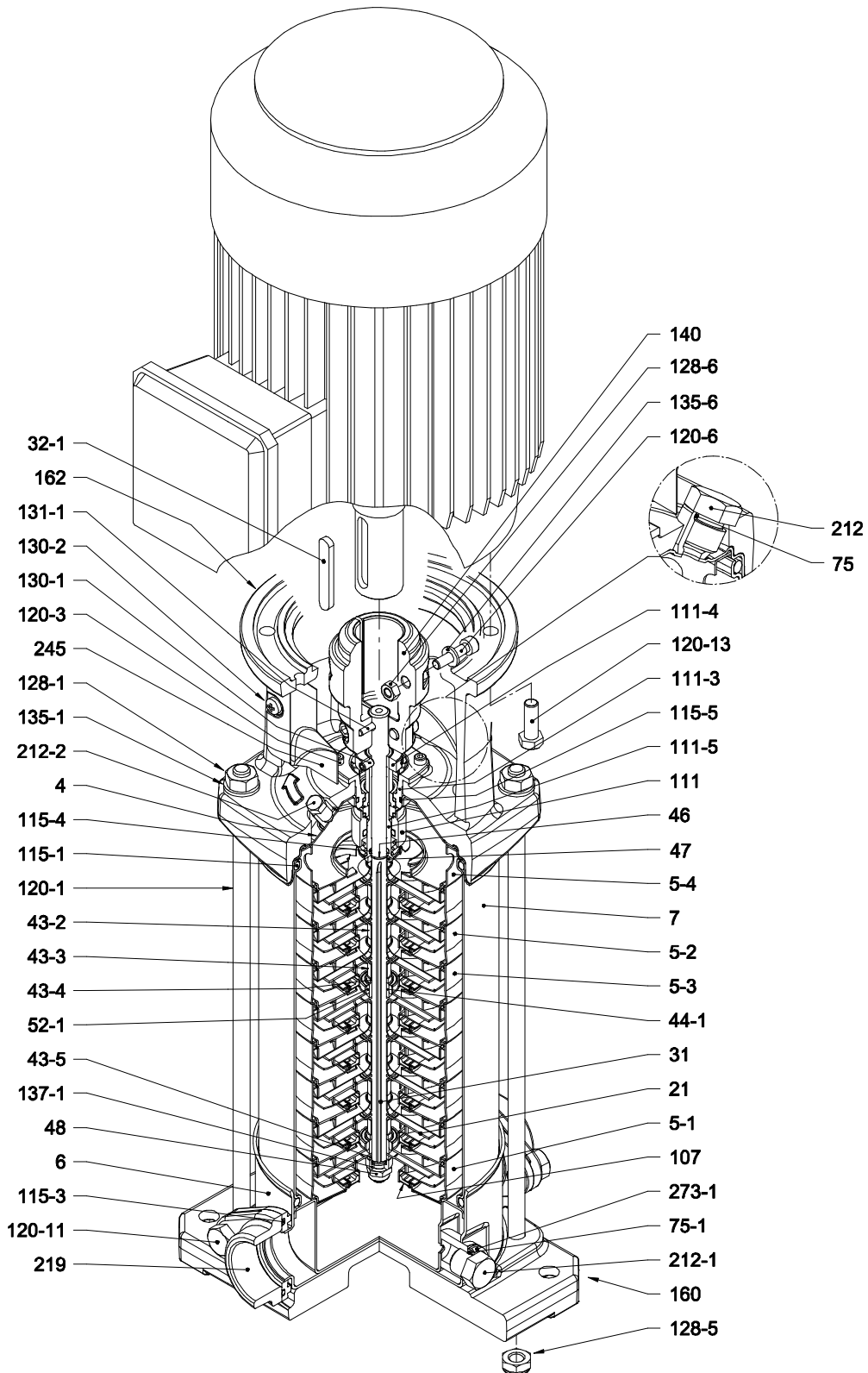

with Oval flange (N)

PIPE CONNECTION EVMS(L)5

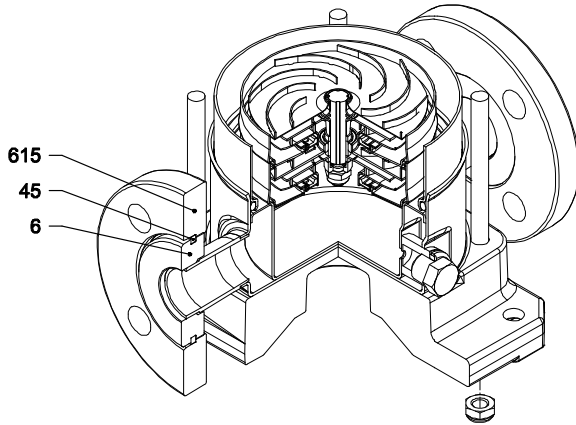

with Loose round flange (LF)

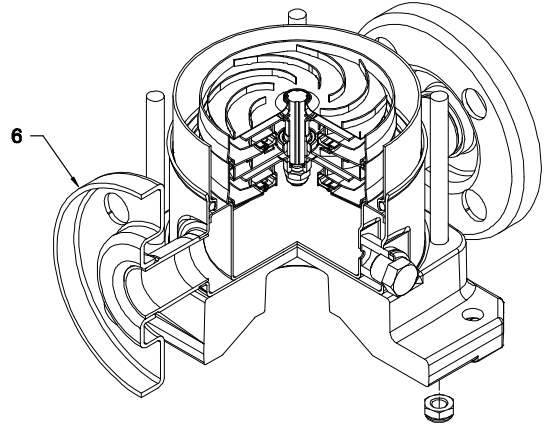

with Round flange (F)

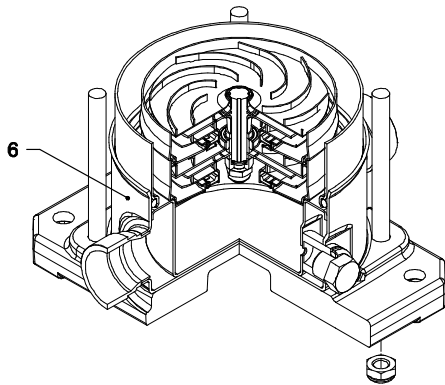

with Victaulic® connection (V)

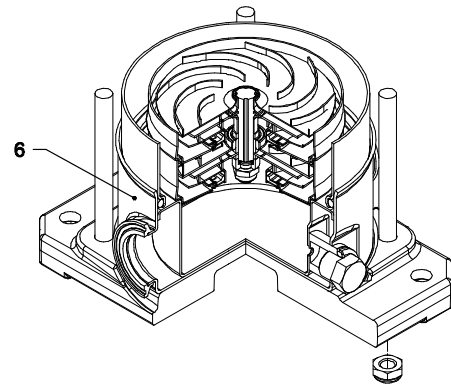

with Clamp connection (C)

SECTIONAL TABLE
EVMS(L)5

N°	PART NAME	MATERIAL		DIMENSIONS	STANDARD
		EVMS	EVMSL		
4	Casing cover	EN 1.4301 (AISI 304)	EN 1.4401 (AISI 316)		
5-1	Suction casing	EN 1.4301 (AISI 304)	EN 1.4401 (AISI 316)		
5-2	Intermediate Casing	EN 1.4301 (AISI 304)	EN 1.4401 (AISI 316)		
5-3	Intermediate casing bearing	EN 1.4301 (AISI 304)	EN 1.4401 (AISI 316)		
5-4	Discharge casing	EN 1.4301 (AISI 304)	EN 1.4401 (AISI 316)		
6	Bottom casing	EN 1.4301 (AISI 304)	EN 1.4401 (AISI 316)		
7	Outer casing	EN 1.4301 (AISI 304)	EN 1.4404 (AISI 316L)		
21	Impeller	EN 1.4301 (AISI 304)	EN 1.4401 (AISI 316)		
31	Shaft	EN 1.4301 (AISI 304) - EN 1.4462 (AISI 329A)	EN 1.4404 (AISI 316L) - EN 1.4462 (AISI 329A)		
32-1	Adjuster Key	EN 1.4301 (AISI 304)			
43-2	Shaft sleeve (intermediate)	EN 1.4301 (AISI 304)	EN 1.4404 (AISI 316L)		
43-3	Shaft sleeve (bearing)	EN 1.4301 (AISI 304)	EN 1.4401 (AISI 316)		
43-4	Shaft sleeve (adjustment)	EN 1.4404 (AISI 316L)			
43-5	Shaft sleeve (last stage)	EN 1.4301 (AISI 304)	EN 1.4401 (AISI 316)		
44-1	Shaft sleeve bearing	Tungsten carbide			
45	Flange holder	EN 1.4301 (AISI 304)			
46	Ring (mechanical seal)	EN 1.4404 (AISI 316L)			
47	Ring Holder	EN 1.4301 (AISI 304)	EN 1.4401 (AISI 316)		
48	Impeller nut	A2-70 UNI 7323 with inox insert	A4-70 UNI 7323 with inox insert	M8	
52-1	Bearing	Tungsten carbide			
75	O-Ring (plug)	EPDM		D. 12.37x2.62	OR 3050
75-1	O-Ring (plug)	EPDM			
107	Liner ring	EN 1.4301 (AISI 304) + PPS	EN 1.4401 (AISI 316) + PPS		
111	Mechanical Seal	SiC/Carbon/EPDM			
111-3	Mechanical seal seat	EN 1.4301 (AISI 304)	EN 1.4401 (AISI 316)		
111-4	Seal holder	EN 1.4301 (AISI 304)			
111-5	Mechanical seal cartridge	EN 1.4301 (AISI 304)	EN 1.4401 (AISI 316)		
115-1	O-Ring (outer casing)	EPDM		D. 129.54x5.34	OR 6510
115-3	O-Ring	EPDM			
115-4	O-Ring (cartridge sleeve)	EPDM		D. 11.91x2.62	OR 115
115-5	O-Ring (seal cover)	EPDM		D. 32.99x2.62	OR 3131
120-1	Tie-rod	Galvanized steel 6.8 strength class ISO 898/1		M10	
120-3	Screw	A2-70 UNI 7323		M4x10	ISO 4762
120-6	Screw for coupling	up to 4.0 kW above 5.5 kW	Galvanized steel	M6x25	ISO 4762
120-11	Screw for counterflange	A2-70 UNI 7323		M8x20	ISO 4762
120-13	Screw for motor	MEC 71-80 MEC 90-100-112 MEC 132	Galvanized steel 8.8 strength class ISO 898/1	M6x20	ISO 4017
				M8x20	ISO 4017
				M12x40	ISO 4017
128-1	Nut for tie rod	Galvanized steel		M10	UNI 5588
128-3	Nut (motor)	Galvanized steel		M12	ISO 4032
128-5	Nut for tie rod	A2-70 UNI 7323		M10	UNI 7474
128-6	Nut for coupling	Galvanized steel		M6	ISO 4032
130-1	Set screw	A2-70 UNI 7323		M5x8	UNI 5923
130-2	Screw for coupling guard	A2-70 UNI 7323		M5x6	UNI 7687
131-1	Pin for shaft	Carbon Steel		D. 4x32	UNI 4838
135-1	Washer	Galvanized steel		D. 10.5x21x2	UNI 6592
135-6	Washer	Carbon Steel		Ø6	
137-1	Impeller spacer	EN 1.4301 (AISI 304)	EN 1.4401 (AISI 316)		
140	Coupling	up to 4.0 kW above 5.5 kW	Die cast Aluminium EN AB-AISI11Cu2 (Fe) Cast Iron		
160	Base	Die cast Aluminium EN AB-AISI11Cu2 (Fe)			
162	Motor bracket	Cast iron EN-GJL-200-EN 1561			
212	Plug	EN 1.4301 (AISI 304)	EN 1.4401 (AISI 316)	G 3/8	
212-1	Plug	EN 1.4301 (AISI 304)	EN 1.4401 (AISI 316)	G 3/8	
212-2	Venting plug	EN 1.4404 (AISI 316L)			
219	Counter flange	EN 1.4301 (AISI 304)	EN 1.4401 (AISI 316)		
245	Coupling guard	EN 1.4301 (AISI 304)			
273-1	Plug Washer	EN 1.4301 (AISI 304)	EN 1.4401 (AISI 316)		
615	Flange	Nodular Cast Iron			

QUANTITY FOR MODEL EVMS(L)5

Pump Type	N°																															
	4	5-1	5-2	5-3	5-4	6	7	21	31***	32-1	43-2	43-3	43-4	43-5	44-1	45**	46	47	48	52-1	75	75-1	107	111	111-3	111-4	111-5	115-1	115-3*	115-4	115-5	
EVMS(L)5 2/0.37	1	1	/	1	1	1	1	2	1	1	/	1	1	/	1	4	2	1	1	1	1	2	2	1	1	1	1	2	2	1	1	
EVMS(L)5 3/0.55	1	1	1	1	1	1	1	3	1	1	3	1	1	1	1	4	2	1	1	1	1	2	3	1	1	1	1	1	2	2	1	1
EVMS(L)5 4/0.75	1	1	2	1	1	1	1	4	1	1	5	1	1	/	1	4	2	1	1	1	1	2	4	1	1	1	1	1	2	2	1	1
EVMS(L)5 5/1.1	1	1	3	1	1	1	1	5	1	1	7	1	1	/	1	4	2	1	1	1	1	2	5	1	1	1	1	1	2	2	1	1
EVMS(L)5 6/1.5	1	1	4	1	1	1	1	6	1	1	9	1	1	1	1	4	2	1	1	1	1	2	6	1	1	1	1	1	2	2	1	1
EVMS(L)5 7/1.5	1	1	5	1	1	1	1	7	1	1	11	1	1	/	1	4	2	1	1	1	1	2	7	1	1	1	1	1	2	2	1	1
EVMS(L)5 8/2.2	1	1	6	1	1	1	1	8	1	1	13	1	1	/	1	4	2	1	1	1	1	2	8	1	1	1	1	1	2	2	1	1
EVMS(L)5 9/2.2	1	1	7	1	1	1	1	9	1	1	15	1	1	1	1	4	2	1	1	1	1	2	9	1	1	1	1	1	2	2	1	1
EVMS(L)5 10/2.2	1	1	8	1	1	1	1	10	1	1	17	1	1	/	1	4	2	1	1	1	1	2	10	1	1	1	1	1	2	2	1	1
EVMS(L)5 11/2.2	1	1	8	2	1	1	1	11	1	1	17	2	2	/	2	4	2	1	1	2	1	2	11	1	1	1	1	1	2	2	1	1
EVMS(L)5 12/3.0	1	1	9	2	1	1	1	12	1	1	19	2	2	1	2	4	2	1	1	2	1	2	12	1	1	1	1	1	2	2	1	1
EVMS(L)5 13/3.0	1	1	10	2	1	1	1	13	1	1	21	2	2	/	2	4	2	1	1	2	1	2	13	1	1	1	1	1	2	2	1	1
EVMS(L)5 14/3.0	1	1	11	2	1	1	1	14	1	1	23	2	2	/	2	4	2	1	1	2	1	2	14	1	1	1	1	1	2	2	1	1
EVMS(L)5 15/3.0	1	1	12	2	1	1	1	15	1	1	25	2	2	1	2	4	2	1	1	2	1	2	15	1	1	1	1	1	2	2	1	1
EVMS(L)5 17/4.0	1	1	14	2	1	1	1	17	1	1	29	2	2	/	2	4	2	1	1	2	1	2	17	1	1	1	1	1	2	2	1	1
EVMS(L)5 19/4.0	1	1	16	2	1	1	1	19	1	1	33	2	2	/	2	4	2	1	1	2	1	2	19	1	1	1	1	1	2	/	1	1
EVMS(L)5 20/4.0	1	1	17	2	1	1	1	20	1	1	35	2	2	/	2	4	2	1	1	2	1	2	20	1	1	1	1	1	2	/	1	1
EVMS(L)5 23/5.5	1	1	20	2	1	1	1	23	1	1	41	2	2	/	2	4	2	1	1	2	1	2	23	1	1	1	1	1	2	/	1	1
EVMS(L)5 25/5.5	1	1	22	2	1	1	1	25	1	1	45	2	2	/	2	4	2	1	1	2	1	2	25	1	1	1	1	1	2	/	1	1
EVMS(L)5 27/5.5	1	1	23	3	1	1	1	27	1	1	47	3	2	/	3	4	2	1	1	3	1	2	27	1	1	1	1	1	2	/	1	1

Pump Type	N°																									
	120-1	120-3	120-6	120-11*	120-13	128-1	128-3	128-5	128-6	130-1	130-2	131-1	135-1	135-6	137-1	140	160	162	212	212-1	212-2	219*	245	273-1	615**	
EVMS(L)5 2/0.37	4	4	4	4	4	4	/	4	4	3	4	1	4	4	1	2	1	1	1	2	1	2	2	2	2	
EVMS(L)5 3/0.55	4	4	4	4	4	4	/	4	4	3	4	1	4	4	1	2	1	1	1	2	1	2	2	2	2	
EVMS(L)5 4/0.75	4	4	4	4	4	4	/	4	4	3	4	1	4	4	1	2	1	1	1	2	1	2	2	2	2	
EVMS(L)5 5/1.1	4	4	4	4	4	4	/	4	4	3	4	1	4	4	1	2	1	1	1	2	1	2	2	2	2	
EVMS(L)5 6/1.5	4	4	4	4	4	4	/	4	4	3	4	1	4	4	1	2	1	1	1	2	1	2	2	2	2	
EVMS(L)5 7/1.5	4	4	4	4	4	4	/	4	4	3	4	1	4	4	1	2	1	1	1	2	1	2	2	2	2	
EVMS(L)5 8/2.2	4	4	4	4	4	4	/	4	4	3	4	1	4	4	1	2	1	1	1	2	1	2	2	2	2	
EVMS(L)5 9/2.2	4	4	4	4	4	4	/	4	4	3	4	1	4	4	1	2	1	1	1	2	1	2	2	2	2	
EVMS(L)5 10/2.2	4	4	4	4	4	4	/	4	4	3	4	1	4	4	1	2	1	1	1	2	1	2	2	2	2	
EVMS(L)5 11/2.2	4	4	4	4	4	4	/	4	4	3	4	1	4	4	1	2	1	1	1	2	1	2	2	2	2	
EVMS(L)5 12/3.0	4	4	4	4	4	4	/	4	4	3	4	1	4	4	1	2	1	1	1	2	1	2	2	2	2	
EVMS(L)5 13/3.0	4	4	4	4	4	4	/	4	4	3	4	1	4	4	1	2	1	1	1	2	1	2	2	2	2	
EVMS(L)5 14/3.0	4	4	4	4	4	4	/	4	4	3	4	1	4	4	1	2	1	1	1	2	1	2	2	2	2	
EVMS(L)5 15/3.0	4	4	4	4	4	4	/	4	4	3	4	1	4	4	1	2	1	1	1	2	1	2	2	2	2	
EVMS(L)5 17/4.0	4	4	4	4	4	4	/	4	4	3	4	1	4	4	1	2	1	1	1	2	1	2	2	2	2	
EVMS(L)5 19/4.0	4	4	4	/	4	4	/	4	4	3	4	1	4	4	1	2	1	1	1	2	1	/	2	2	2	
EVMS(L)5 20/4.0	4	4	4	/	4	4	/	4	4	3	4	1	4	4	1	2	1	1	1	2	1	/	2	2	2	
EVMS(L)5 23/5.5	4	4	4	/	4	4	/	3	4	1	4	/	1	2	1	1	1	1	2	1	/	2	2	2	2	
EVMS(L)5 25/5.5	4	4	4	/	4	4	/	3	4	1	4	/	1	2	1	1	1	1	2	1	/	2	2	2	2	
EVMS(L)5 27/5.5	4	4	4	/	4	4	/	3	4	1	4	/	1	2	1	1	1	1	2	1	/	2	2	2	2	

* only for Oval flange (N)

** only for Loose round flange (LF)

*** shaft in EN 1.4462 (AISI 329A)

128-3: only for motor up to 5.5 kW (see drawing pag.247)

EVMS(L)5

PERFORMANCE CURVE
EVMSG5

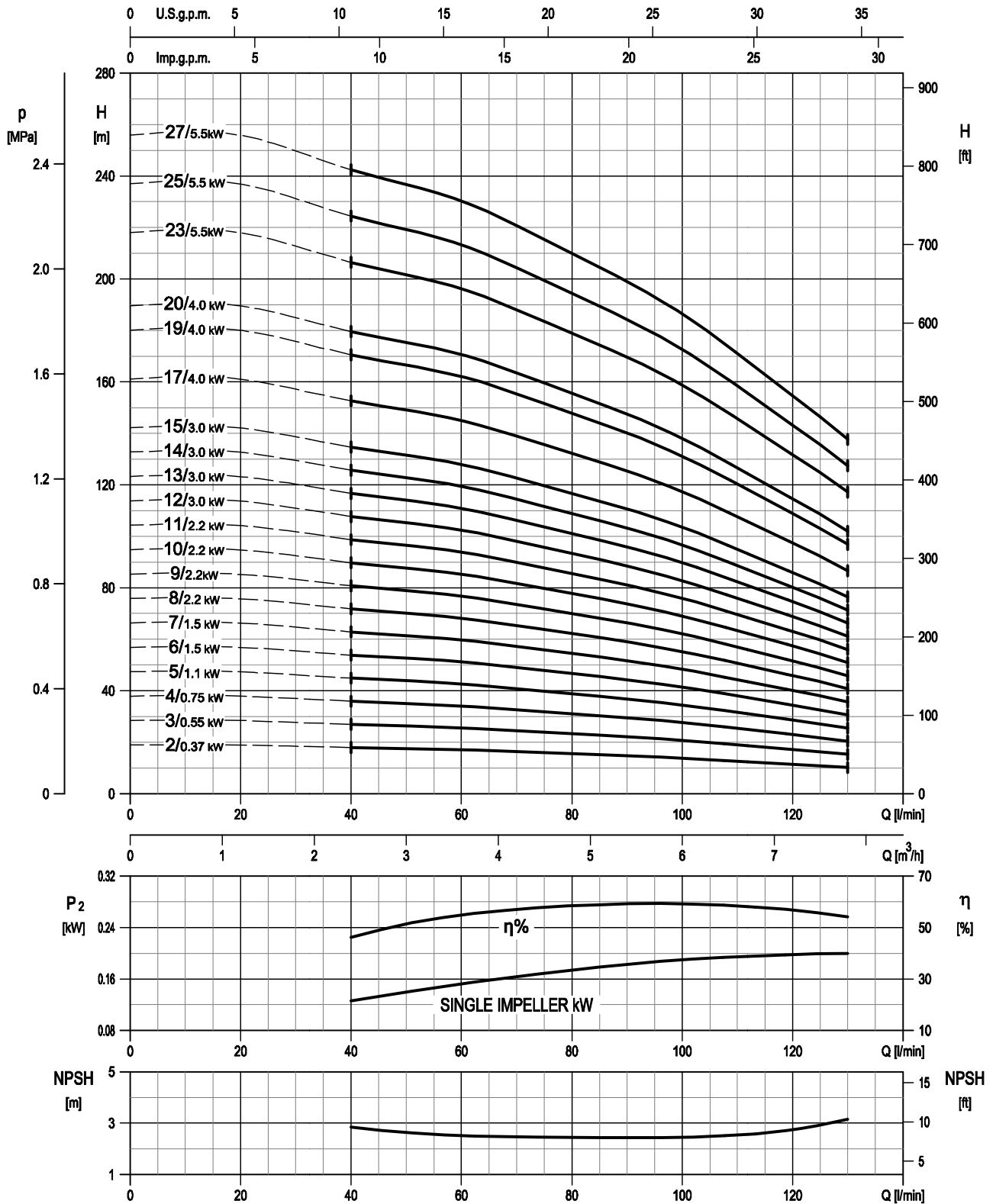

Rotation speed $\approx 2900 \text{ min}^{-1}$
Test standard: ISO 9906:2012 - Grade 3B

TECHNICAL DATA EVMSG5

2.10

Dimensional sketch

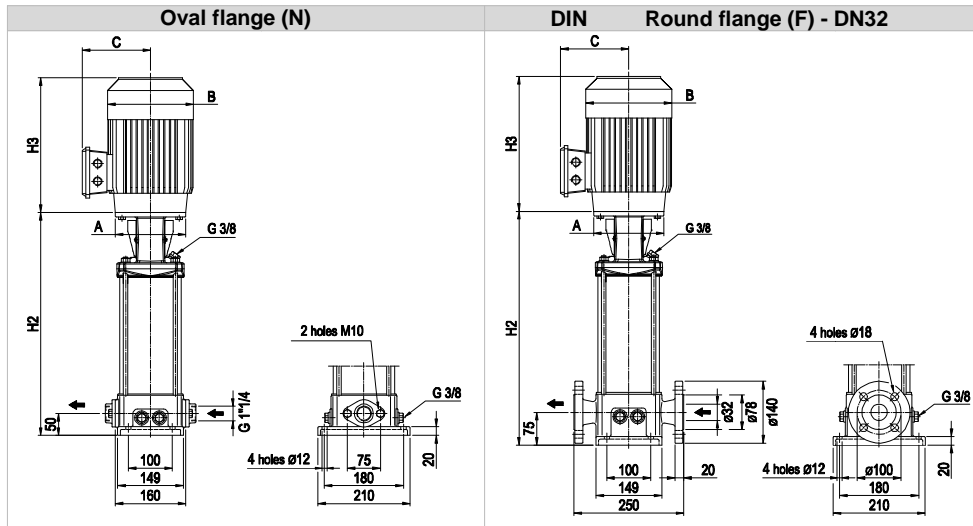

Dimensions [mm] and Weights [Kg]

Pump Type	P _{max} [MPa]	kW	Size	Motor									Oval flange (N)				Round flange (F)			
				A			1 ~			3 ~			H2	Weight Pump	Weight Pump + Motor		H2	Weight Pump	Weight Pump + Motor	
				B	C	H3	B	C	H3	B	C	H3			1 ~	3 ~			1 ~	3 ~
EVMSG5 2/0.37	1.6	0.37	71	ø105	139	133	216	139	114	216	264	13	20.1	18.8	289	17.5	24.6	23.3		
EVMSG5 3/0.55	1.6	0.55	71	ø105	139	133	216	139	114	216	292	13.5	22	19.7	317	18	26.5	24.2		
EVMSG5 4/0.75	1.6	0.75	80	ø120	160	151	232	160	139	232	330	14.5	25.9	24	355	19	30.4	28.5		
EVMSG5 5/1.1	1.6	1.1	80	ø120	160	151	232	160	139	232	358	15	26.8	26.1	383	19.5	31.3	30.6		
EVMSG5 6/1.5	1.6	1.5	90 S	ø140	172	140	278	180	148	267	396	15.5	33.3	28.2	421	20.1	37.9	32.8		
EVMSG5 7/1.5	1.6	1.5	90 S	ø140	172	140	278	180	148	267	424	16	33.8	29	449	20.5	38.3	33.2		
EVMSG5 8/2.2	1.6	2.2	90 L	ø140	172	140	278	180	148	267	452	16.6	36.1	32.6	477	21.1	40.6	37.1		
EVMSG5 9/2.2	1.6	2.2	90 L	ø140	172	140	278	180	148	267	480	17.1	36.6	33.1	505	21.6	41.1	37.6		
EVMSG5 10/2.2	1.6	2.2	90 L	ø140	172	140	278	180	148	267	508	17.6	37.1	33.6	533	22.1	41.6	38.1		
EVMSG5 11/2.2	1.6	2.2	90 L	ø140	172	140	278	180	148	267	536	18.4	37.9	34.4	561	22.9	42.4	38.9		
EVMSG5 12/3.0	1.6	3.0	100 L	ø160	-	-	-	196	155	306	574	19.6	-	42.4	599	24.1	-	46.9		
EVMSG5 13/3.0	1.6	3.0	100 L	ø160	-	-	-	196	155	306	602	20.2	-	43	627	24.7	-	47.5		
EVMSG5 14/3.0	1.6	3.0	100 L	ø160	-	-	-	196	155	306	630	20.8	-	43.6	655	25.3	-	48.1		
EVMSG5 15/3.0	1.6	3.0	100 L	ø160	-	-	-	196	155	306	658	21.8	-	44.6	683	26.3	-	49.1		
EVMSG5 17/4.0	1.6	4.0	112 M	ø160	-	-	-	196	155	306	714	22.5	-	49	739	27	-	53.5		
EVMSG5 19/4.0	2.5	4.0	112 M	ø160	-	-	-	196	155	306	-	-	-	-	795	28.1	-	54.6		
EVMSG5 20/4.0	2.5	4.0	112 M	ø160	-	-	-	196	155	306	-	-	-	-	823	30.3	-	56.8		
EVMSG5 23/5.5	2.5	5.5	132 S	ø300	-	-	-	225	160	328	-	-	-	-	1001	37	-	75.6		
EVMSG5 25/5.5	2.5	5.5	132 S	ø300	-	-	-	225	160	328	-	-	-	-	1057	38	-	76.6		
EVMSG5 27/5.5	2.5	5.5	132 S	ø300	-	-	-	225	160	328	-	-	-	-	1113	39.6	-	78.2		

1.6 MPa=16 bar ; 2.5 MPa=25 bar
- not available model

SECTIONAL VIEW
EVMSG5

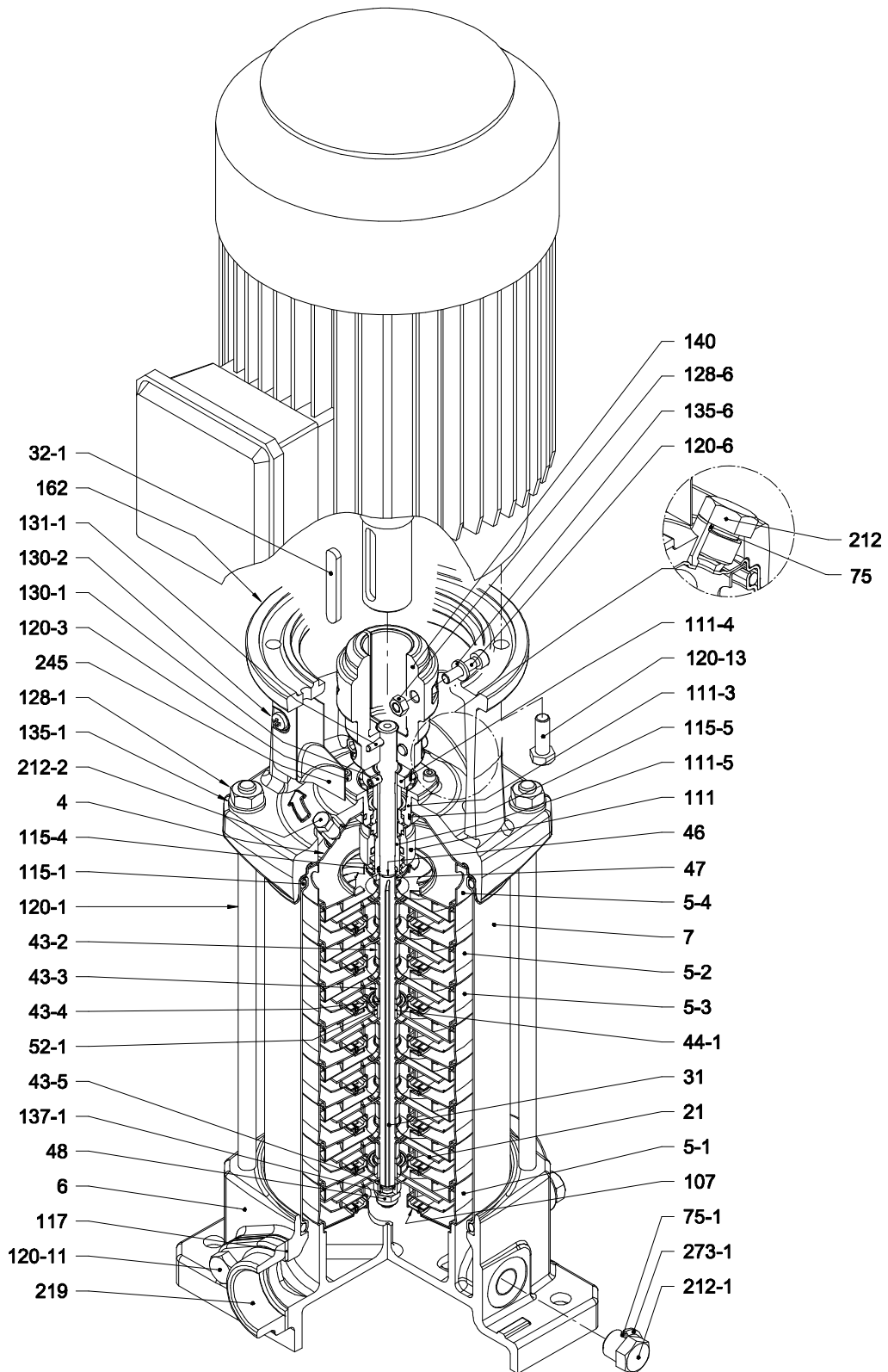

with Oval flange (N)

PIPE CONNECTION EVMSG5

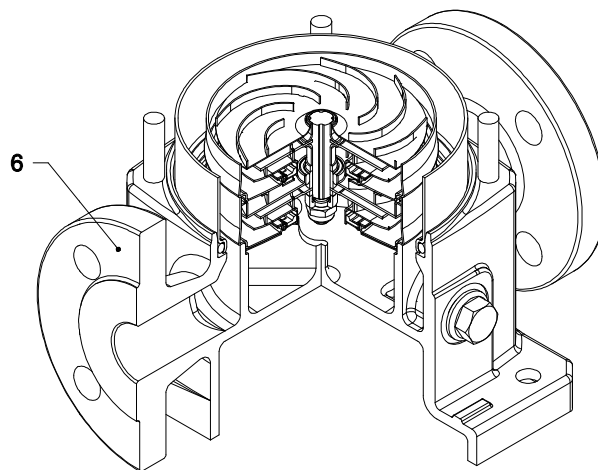

with Round flange (F)

SECTIONAL TABLE
EVMSG5

N°	PART NAME	MATERIAL EVMSG	DIMENSIONS	STANDARD
4	Casing cover	EN 1.4301 (AISI 304)		
5-1	Suction casing	EN 1.4301 (AISI 304)		
5-2	Intermediate Casing	EN 1.4301 (AISI 304)		
5-3	Intermediate casing bearing	EN 1.4301 (AISI 304)		
5-4	Discharge casing	EN 1.4301 (AISI 304)		
6	Bottom casing	Cast Iron EN GJL-250-EN1561		
7	Outer casing	EN 1.4301 (AISI 304)		
21	Impeller	EN 1.4301 (AISI 304)		
31	Shaft	EN 1.4301 (AISI 304) - EN 1.4462 (AISI 329A)		
32-1	Adjuster Key	EN 1.4301 (AISI 304)		
43-2	Shaft sleeve (intermediate)	EN 1.4301 (AISI 304)		
43-3	Shaft sleeve (bearing)	EN 1.4301 (AISI 304)		
43-4	Shaft sleeve (adjustment)	EN 1.4404 (AISI 316L)		
43-5	Shaft sleeve (last stage)	EN 1.4301 (AISI 304)		
44-1	Shaft sleeve bearing	Tungsten carbide		
46	Ring (mechanical seal)	EN 1.4404 (AISI 316L)		
47	Ring Holder	EN 1.4301 (AISI 304)		
48	Impeller nut	A2-70 UNI 7323 with inox insert	M8	
52-1	Bearing	Tungsten carbide		
75	O-Ring (plug)	EPDM	D. 12.37x2.62	OR 3050
75-1	O-Ring (plug)	EPDM		
107	Liner ring	EN 1.4301 (AISI 304) + PPS		
111	Mechanical Seal	SiC/Carbon/EPDM		
111-3	Mechanical seal seat	EN 1.4301 (AISI 304)		
111-4	Seal holder	EN 1.4301 (AISI 304)		
111-5	Mechanical seal cartridge	EN 1.4301 (AISI 304)		
115-1	O-Ring (outer casing)	EPDM	D. 129.54x5.34	OR 6510
115-4	O-Ring (cartridge sleeve)	EPDM	D. 11.91x2.62	OR 115
115-5	O-Ring (seal cover)	EPDM	D. 32.99x2.62	OR 3131
117	Flange gasket	EPDM		
120-1	Tie-rod	Galvanized steel 6.8 strength class ISO 898/1	M10	
120-3	Screw	A2-70 UNI 7323	M4x10	ISO 4762
120-6	Screw for coupling	Galvanized steel	M6x25	ISO 4762
			M8x20	ISO 4762
120-11	Screw for counterflange	A2-70 UNI 7323		
120-13	Screw for motor	Galvanized steel 8.8 strength class ISO 898/1	M6x20	ISO 4017
			M8x20	ISO 4017
			M12x40	ISO 4017
128-1	Nut for tie rod	Galvanized steel	M10	UNI 5588
128-3	Nut (motor)	Galvanized steel	M12	ISO 4032
128-6	Nut for coupling	Galvanized steel	M6	ISO 4032
130-1	Set screw	A2-70 UNI 7323	M5x8	UNI 5923
130-2	Screw for coupling guard	A2-70 UNI 7323	M5x6	UNI 7687
131-1	Pin for shaft	Carbon Steel	D. 4x32	UNI 4838
135-1	Washer	Galvanized steel	D. 10.5x21x2	UNI 6592
135-6	Washer	Carbon Steel	Ø6	
137-1	Impeller spacer	EN 1.4301 (AISI 304)		
140	Coupling	Die cast aluminium EN AB-AISI11Cu2 (Fe) Cast Iron		
162	Motor bracket	Cast iron EN-GJL-200-EN 1561		
212	Plug	EN 1.4301 (AISI 304)	G 3/8	
212-1	Plug	EN 1.4301 (AISI 304)	G 3/8	
212-2	Venting plug	EN 1.4404 (AISI 316L)		
219	Counter flange	Galvanized steel		
245	Coupling guard	EN 1.4301 (AISI 304)		
273-1	Plug Washer	EN 1.4301 (AISI 304)		

QUANTITY FOR MODEL EVMSG5

Pump Type	N°																												
	4	5-1	5-2	5-3	5-4	6	7	21	31***	32-1	43-2	43-3	43-4	43-5	44-1	46	47	48	52-1	75	75-1	107	111	111-3	111-4	111-5	115-1	115-4	115-5
EVMSG5 2/0.37	1	1	/	1	1	1	1	2	1	1	/	1	1	/	1	2	1	1	1	1	4	2	1	1	1	1	2	1	1
EVMSG5 3/0.55	1	1	1	1	1	1	1	3	1	1	3	1	1	1	1	2	1	1	1	1	4	3	1	1	1	1	2	1	1
EVMSG5 4/0.75	1	1	2	1	1	1	1	4	1	1	5	1	1	/	1	2	1	1	1	1	4	4	1	1	1	1	2	1	1
EVMSG5 5/1.1	1	1	3	1	1	1	1	5	1	1	7	1	1	/	1	2	1	1	1	1	4	5	1	1	1	1	2	1	1
EVMSG5 6/1.5	1	1	4	1	1	1	1	6	1	1	9	1	1	1	1	2	1	1	1	1	4	6	1	1	1	1	2	1	1
EVMSG5 7/1.5	1	1	5	1	1	1	1	7	1	1	11	1	1	/	1	2	1	1	1	1	4	7	1	1	1	1	2	1	1
EVMSG5 8/2.2	1	1	6	1	1	1	1	8	1	1	13	1	1	/	1	2	1	1	1	1	4	8	1	1	1	1	2	1	1
EVMSG5 9/2.2	1	1	7	1	1	1	1	9	1	1	15	1	1	1	1	2	1	1	1	1	4	9	1	1	1	1	2	1	1
EVMSG5 10/2.2	1	1	8	1	1	1	1	10	1	1	17	1	1	/	1	2	1	1	1	1	4	10	1	1	1	1	2	1	1
EVMSG5 11/2.2	1	1	8	2	1	1	1	11	1	1	17	2	2	/	2	2	1	1	2	1	4	11	1	1	1	1	2	1	1
EVMSG5 12/3.0	1	1	9	2	1	1	1	12	1	1	19	2	2	1	2	2	1	1	2	1	4	12	1	1	1	1	2	1	1
EVMSG5 13/3.0	1	1	10	2	1	1	1	13	1	1	21	2	2	/	2	2	1	1	2	1	4	13	1	1	1	1	2	1	1
EVMSG5 14/3.0	1	1	11	2	1	1	1	14	1	1	23	2	2	/	2	2	1	1	2	1	4	14	1	1	1	1	2	1	1
EVMSG5 15/3.0	1	1	12	2	1	1	1	15	1	1	25	2	2	1	2	2	1	1	2	1	4	15	1	1	1	1	2	1	1
EVMSG5 17/4.0	1	1	14	2	1	1	1	17	1	1	29	2	2	/	2	2	1	1	2	1	4	17	1	1	1	1	2	1	1
EVMSG5 19/4.0	1	1	16	2	1	1	1	19	1	1	33	2	2	/	2	2	1	1	2	1	4	19	1	1	1	1	2	1	1
EVMSG5 20/4.0	1	1	17	2	1	1	1	20	1	1	35	2	2	/	2	2	1	1	2	1	4	20	1	1	1	1	2	1	1
EVMSG5 23/5.5	1	1	20	2	1	1	1	23	1	1	41	2	2	/	2	2	1	1	2	1	4	23	1	1	1	1	2	1	1
EVMSG5 25/5.5	1	1	22	2	1	1	1	25	1	1	45	2	2	/	2	2	1	1	2	1	4	25	1	1	1	1	2	1	1
EVMSG5 27/5.5	1	1	23	3	1	1	1	27	1	1	47	3	2	/	3	2	1	1	3	1	4	27	1	1	1	1	2	1	1

Pump Type	N°																						
	117*	120-1	120-3	120-6	120-11*	120-13	128-1	128-3	128-6	130-1	130-2	131-1	135-1	135-6	137-1	140	162	212	212-1	212-2	219*	245	273-1
EVMSG5 2/0.37	2	4	4	4	4	4	4	/	4	3	4	1	4	4	1	2	1	1	4	1	2	2	4
EVMSG5 3/0.55	2	4	4	4	4	4	4	/	4	3	4	1	4	4	1	2	1	1	4	1	2	2	4
EVMSG5 4/0.75	2	4	4	4	4	4	4	/	4	3	4	1	4	4	1	2	1	1	4	1	2	2	4
EVMSG5 5/1.1	2	4	4	4	4	4	4	/	4	3	4	1	4	4	1	2	1	1	4	1	2	2	4
EVMSG5 6/1.5	2	4	4	4	4	4	4	/	4	3	4	1	4	4	1	2	1	1	4	1	2	2	4
EVMSG5 7/1.5	2	4	4	4	4	4	4	/	4	3	4	1	4	4	1	2	1	1	4	1	2	2	4
EVMSG5 8/2.2	2	4	4	4	4	4	4	/	4	3	4	1	4	4	1	2	1	1	4	1	2	2	4
EVMSG5 9/2.2	2	4	4	4	4	4	4	/	4	3	4	1	4	4	1	2	1	1	4	1	2	2	4
EVMSG5 10/2.2	2	4	4	4	4	4	4	/	4	3	4	1	4	4	1	2	1	1	4	1	2	2	4
EVMSG5 11/2.2	2	4	4	4	4	4	4	/	4	3	4	1	4	4	1	2	1	1	4	1	2	2	4
EVMSG5 12/3.0	2	4	4	4	4	4	4	/	4	3	4	1	4	4	1	2	1	1	4	1	2	2	4
EVMSG5 13/3.0	2	4	4	4	4	4	4	/	4	3	4	1	4	4	1	2	1	1	4	1	2	2	4
EVMSG5 14/3.0	2	4	4	4	4	4	4	/	4	3	4	1	4	4	1	2	1	1	4	1	2	2	4
EVMSG5 15/3.0	2	4	4	4	4	4	4	/	4	3	4	1	4	4	1	2	1	1	4	1	2	2	4
EVMSG5 17/4.0	2	4	4	4	4	4	4	/	4	3	4	1	4	4	1	2	1	1	4	1	2	2	4
EVMSG5 19/4.0	/	4	4	4	/	4	4	/	4	3	4	1	4	4	1	2	1	1	4	1	/	2	4
EVMSG5 20/4.0	/	4	4	4	/	4	4	/	4	3	4	1	4	4	1	2	1	1	4	1	/	2	4
EVMSG5 23/5.5	/	4	4	4	/	4	4	4	/	3	4	1	4	/	1	2	1	1	4	1	/	2	4
EVMSG5 25/5.5	/	4	4	4	/	4	4	4	/	3	4	1	4	/	1	2	1	1	4	1	/	2	4
EVMSG5 27/5.5	/	4	4	4	/	4	4	4	/	3	4	1	4	/	1	2	1	1	4	1	/	2	4

* only for Oval flange (N)

*** shaft in EN 1.4462 (AISI 329A)

128-3: only for motor up to 5.5 kW (see drawing pag.247)

PERFORMANCE CURVE
EVMS(L)10

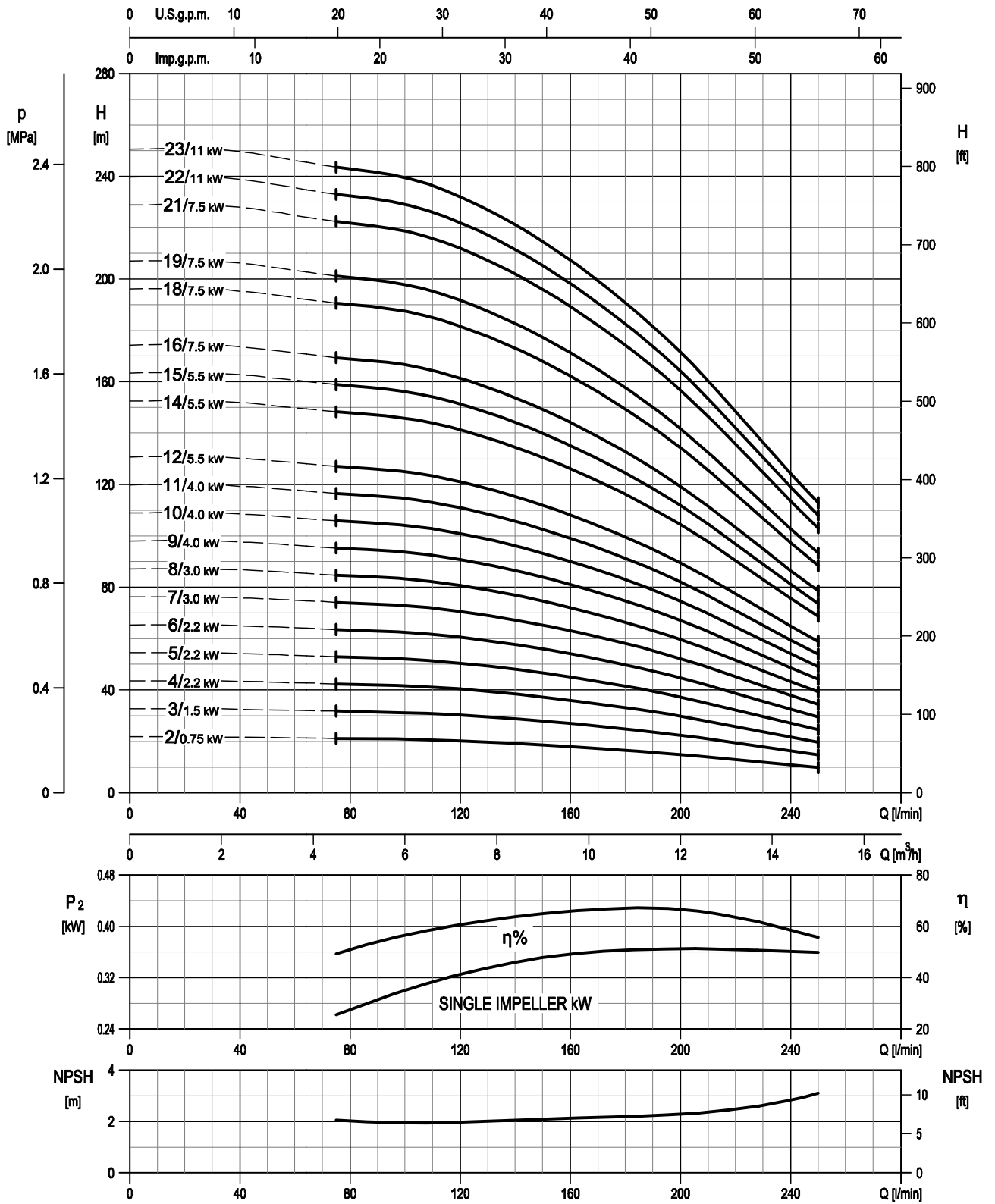

Rotation speed $\approx 2900 \text{ min}^{-1}$
Test standard: ISO 9906:2012 - Grade 3B

TECHNICAL DATA EVMS(L)10

Dimensional sketch

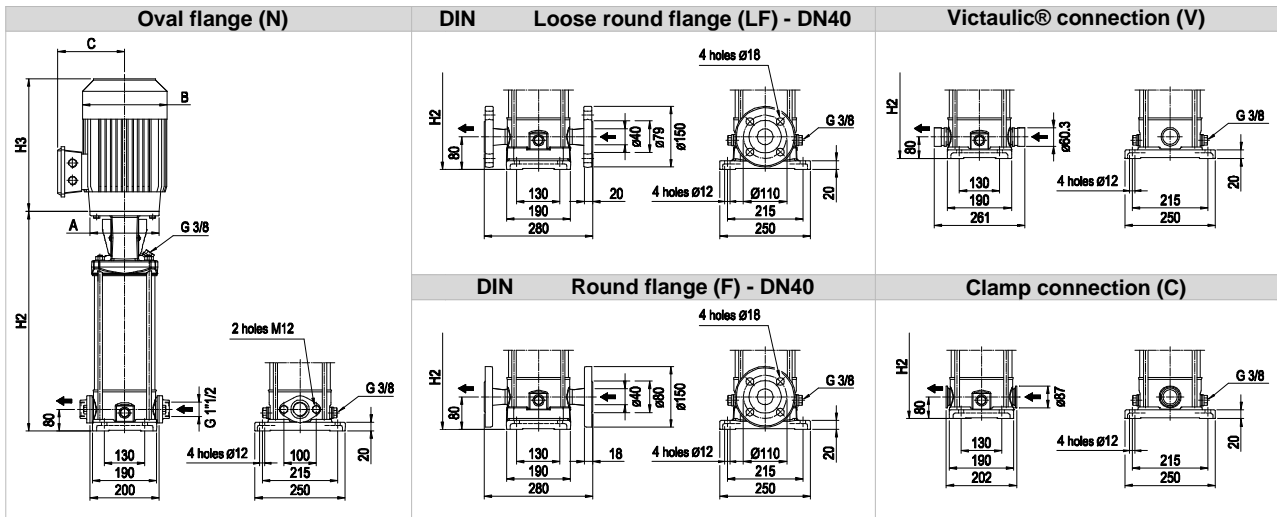

Dimensions [mm] and Weights [Kg]

Pump Type	Pmax [MPa]	kW	Motor									Oval flange (N)			Loose round flange (LF) Round flange (F)			Victaulic® connection (V) Clamp connection (C)						
			Size	A			1 ~			3 ~			H2	Weight Pump	Weight Pump + Motor		H2	Weight Pump	Weight Pump + Motor		H2	Weight Pump	Weight Pump + Motor	
				B	C	H3	B	C	H3	B	C	H3			1 ~	3 ~			1 ~	3 ~			1 ~	3 ~
EVMS(L)10 2/0.75	1.6	0.75	80	120	160	151	232	160	139	232	343	17.6	29	27.1	343	17.5	28.9	27	343	16.5	27.9	26		
EVMS(L)10 3/1.5	1.6	1.5	90 S	140	172	140	278	180	148	267	383	18.5	36.3	31.2	383	18.5	36.3	31.2	383	17.4	35.2	30.1		
EVMS(L)10 4/2.2	1.6	2.2	90 L	140	172	140	278	180	148	267	413	19.3	38.8	35.3	413	19.3	38.8	35.3	413	18.2	38	34.2		
EVMS(L)10 5/2.2	1.6	2.2	90 L	140	172	140	278	180	148	267	443	20.2	39.7	36.2	443	20.1	39.6	36.1	443	19.1	38.6	35.1		
EVMS(L)10 6/2.2	1.6	2.2	90 L	140	172	140	278	180	148	267	473	21	40.5	37	473	21	40.5	37	473	19.9	39.4	35.9		
EVMS(L)10 7/3.0	1.6	3.0	100 L	160	-	-	-	196	155	306	513	22	-	44.8	513	21.9	-	44.7	513	20.9	-	43.7		
EVMS(L)10 8/3.0	1.6	3.0	100 L	160	-	-	-	196	155	306	543	22.8	-	45.6	543	22.8	-	45.6	543	21.7	-	44.5		
EVMS(L)10 9/4.0	1.6	4.0	112 M	160	-	-	-	196	155	306	573	23.7	-	50.2	573	23.6	-	50.1	573	22.6	-	49.1		
EVMS(L)10 10/4.0	1.6	4.0	112 M	160	-	-	-	196	155	306	603	24.5	-	51	603	24.5	-	51	603	23.4	-	49.9		
EVMS(L)10 11/4.0	1.6	4.0	112 M	160	-	-	-	196	155	306	633	26.1	-	52.6	633	26.1	-	52.6	633	25	-	51.5		
EVMS(L)10 12/5.5	1.6	5.5	132 S	300	-	-	-	225	160	328	761	35.9	-	74.5	761	35.9	-	74.5	761	34.8	-	73.4		
EVMS(L)10 14/5.5	1.6	5.5	132 S	300	-	-	-	225	160	328	821	37.8	-	76.4	821	37.7	-	76.3	821	36.7	-	75.3		
EVMS(L)10 15/5.5	1.6	5.5	132 S	300	-	-	-	225	160	328	851	38.7	-	77.3	851	38.6	-	77.2	851	37.6	-	76.2		
EVMS(L)10 16/7.5	2.5	7.5	132 S	300	-	-	-	225	160	350	-	-	-	-	881	39.6	-	80	881	38.5	-	78.9		
EVMS(L)10 18/7.5	2.5	7.5	132 S	300	-	-	-	225	160	350	-	-	-	-	941	41.4	-	81.8	941	40.3	-	80.7		
EVMS(L)10 19/7.5	2.5	7.5	132 S	300	-	-	-	225	160	350	-	-	-	-	971	42.3	-	82.7	971	41.2	-	81.6		
EVMS(L)10 21/7.5	2.5	7.5	132 S	300	-	-	-	225	160	350	-	-	-	-	1031	44.1	-	84.5	1031	43.1	-	83.5		
EVMS(L)10 22/11	2.5	11	160 M	350	-	-	-	248	194	476	-	-	-	-	1091	46.4	-	108.9	1091	45.4	-	107.9		
EVMS(L)10 23/11	2.5	11	160 M	350	-	-	-	248	194	476	-	-	-	-	1121	53.1	-	115.6	1121	52.1	-	114.6		

1.6 MPa=16 bar ; 2.5 MPa=25 bar
- not available model

SECTIONAL VIEW
EVMS(L)10

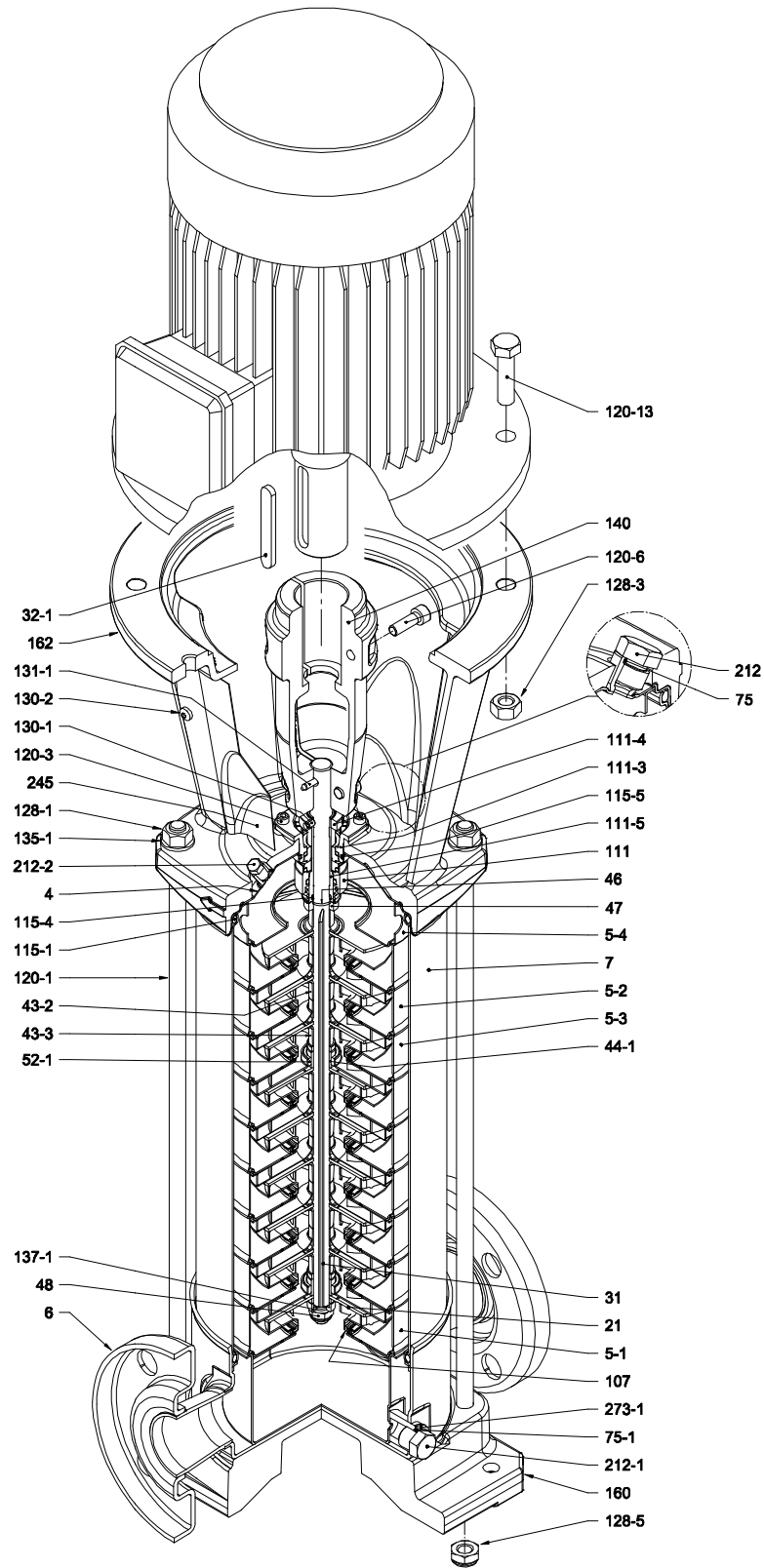

with Round flange (F)

PIPE CONNECTION EVMS(L)10

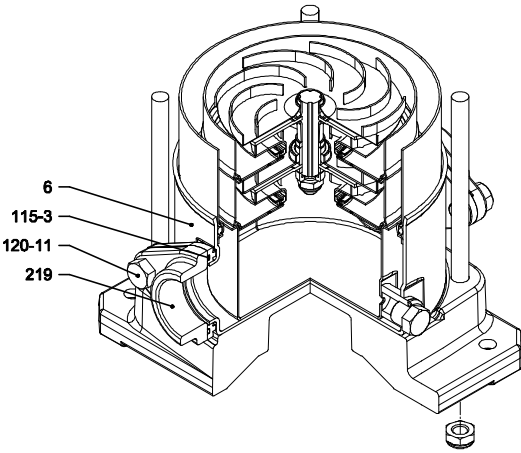

with Oval flange (N)

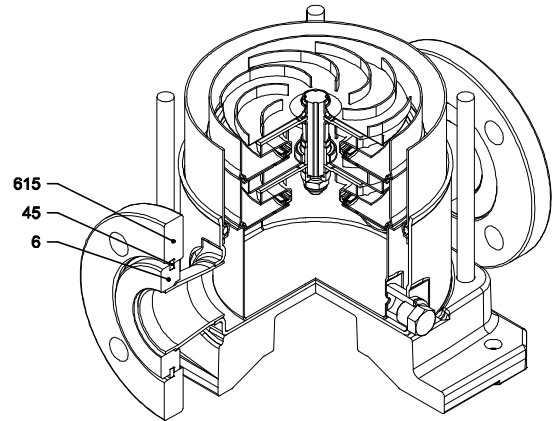

with Loose round flange (LF)

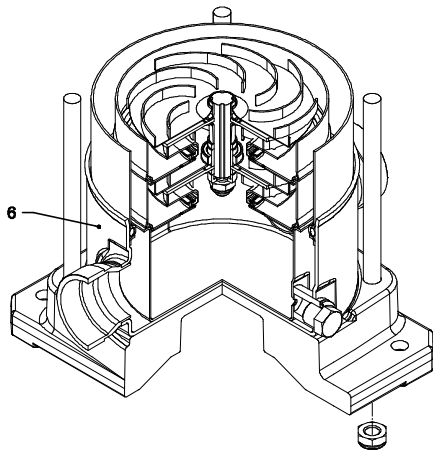

with Victaulic® connection (V)

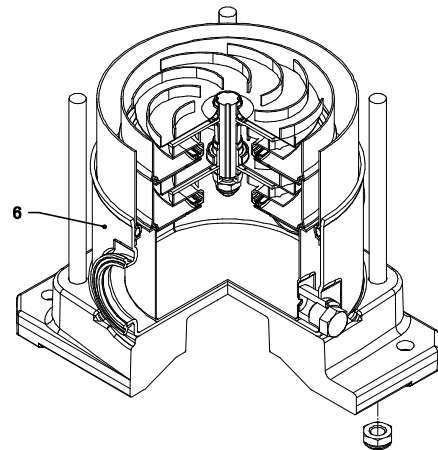

with Clamp connection (C)

SECTIONAL TABLE
EVMS(L)10

N°	PART NAME	MATERIAL		DIMENSIONS	STANDARD
		EVMS	EVMSL		
4	Casing cover	EN 1.4301 (AISI 304)	EN 1.4401 (AISI 316)		
5-1	Suction casing	EN 1.4301 (AISI 304)	EN 1.4401 (AISI 316)		
5-2	Intermediate Casing	EN 1.4301 (AISI 304)	EN 1.4401 (AISI 316)		
5-3	Intermediate casing bearing	EN 1.4301 (AISI 304)	EN 1.4401 (AISI 316)		
5-4	Discharge casing	EN 1.4301 (AISI 304)	EN 1.4401 (AISI 316)		
6	Bottom casing	EN 1.4301 (AISI 304)	EN 1.4401 (AISI 316)		
7	Outer casing	EN 1.4301 (AISI 304)	EN 1.4404 (AISI 316L)		
21	Impeller	EN 1.4301 (AISI 304)	EN 1.4401 (AISI 316)		
31	Shaft	EN 1.4301 (AISI 304)	EN 1.4404 (AISI 316L)		
32-1	Adjuster Key	EN 1.4301 (AISI 304)			
43-2	Shaft sleeve (intermediate)	EN 1.4301 (AISI 304)	EN 1.4404 (AISI 316L)		
43-3	Shaft sleeve (bearing)	EN 1.4301 (AISI 304)	EN 1.4401 (AISI 316)		
44-1	Shaft sleeve bearing	Tungsten carbide			
45	Flange holder	EN 1.4301 (AISI 304)			
46	Ring (mechanical seal)	EN 1.4404 (AISI 316L)			
47	Ring Holder	EN 1.4301 (AISI 304)	EN 1.4401 (AISI 316)		
48	Impeller nut	A2-70 UNI 7323 with inox insert	A4-70 UNI 7323 with inox insert	M10	
52-1	Bearing	Tungsten carbide			
75	O-Ring (plug)	EPDM		D. 12.37x2.62	OR 3050
75-1	O-Ring (plug)	EPDM			
107	Liner ring	EN 1.4301 (AISI 304) + PPS	EN 1.4401 (AISI 316) + PPS		
111	Mechanical Seal	SiC/Carbon/EPDM			
111-3	Mechanical seal seat	EN 1.4301 (AISI 304)	EN 1.4401 (AISI 316)		
111-4	Seal holder	EN 1.4301 (AISI 304)			
111-5	Mechanical seal cartridge	EN 1.4301 (AISI 304)	EN 1.4401 (AISI 316)		
115-1	O-Ring (outer casing)	EPDM		D. 164,46x5,34	OR 6645
115-3	O-Ring	EPDM			
115-4	O-Ring (cartridge sleeve)	EPDM		D. 15.88x2.62	OR 121
115-5	O-Ring (seal cover)	EPDM		D. 37.77x2.62	OR 3150
120-1	Tie-rod	Galvanized steel 6.8 strength class ISO 898/1		M12	
120-3	Screw	A2-70 UNI 7323		M5x12	ISO 4762
120-6	Screw for coupling	up to 4.0 kW from 5.5 kW to 7.5 kW above 11 kW	Galvanized steel	M6x25	ISO 4762
				M8x20	ISO 4762
				M10x30	ISO 4762
120-11	Screw for counterflange	A2-70 UNI 7323			
120-13	Screw for motor	MEC 80 MEC 90-100-112 MEC 132 MEC 160	Galvanized steel 8.8 strength class ISO 898/1	M6x20	ISO 4017
				M8x20	ISO 4017
				M12x40	UNI 5739
				M16x50	ISO 4017
128-1	Nut for tie rod	Galvanized steel		M12	UNI 5588
128-3	Nut (motor)	MEC 132 MEC 160	Galvanized steel	M12	UNI 5588
				M16	ISO 4032
128-5	Nut for tie rod	Galvanized steel		M12	UNI 7474
130-1	Set screw	A2-70 UNI 7323		M5x8	UNI 5923
130-2	Screw for coupling guard	A2-70 UNI 7323		M5x6	UNI 7687
131-1	Pin for shaft	Carbon Steel		D. 5x35	UNI 4838
135-1	Washer	Galvanized steel		D. 13x24x2,5	UNI 6592
137-1	Impeller spacer	EN 1.4301 (AISI 304)	EN 1.4401 (AISI 316)		
140	Coupling	Die cast Aluminium EN AB-AISI11Cu2 (Fe) Cast Iron			
160	Base	Die cast Aluminium EN AB-AISI11Cu2 (Fe) Cast Iron EN-GJL-200-EN 1561			
162	Motor bracket	Cast iron EN-GJL-200-EN 1561			
212	Plug	EN 1.4301 (AISI 304)	EN 1.4401 (AISI 316)	G 3/8	
212-1	Plug	EN 1.4301 (AISI 304)	EN 1.4401 (AISI 316)	G 3/8	
212-2	Venting plug	EN 1.4404 (AISI 316L)			
219	Counter flange	EN 1.4301 (AISI 304)	EN 1.4401 (AISI 316)		
245	Coupling guard	EN 1.4301 (AISI 304)			
273-1	Plug Washer	EN 1.4301 (AISI 304)	EN 1.4401 (AISI 316)		
615	Flange	Nodular Cast Iron			

QUANTITY FOR MODEL EVMS(L)10

Pump Type	N°																												
	4	5-1	5-2	5-3	5-4	6	7	21	31	32-1	43-2	43-3	44-1	45**	46	47	48	52-1	75	75-1	107	111	111-3	111-4	111-5	115-1	115-3*	115-4	115-5
EVMS(L)10 2/0.75	1	1	/	1	1	1	1	2	1	1	/	1	1	4	2	1	1	1	1	2	2	1	1	1	1	2	2	1	1
EVMS(L)10 3/1.5	1	1	1	1	1	1	1	3	1	1	3	1	1	4	2	1	1	1	1	2	3	1	1	1	1	2	2	1	1
EVMS(L)10 4/2.2	1	1	2	1	1	1	1	4	1	1	5	1	1	4	2	1	1	1	1	2	4	1	1	1	1	2	2	1	1
EVMS(L)10 5/2.2	1	1	3	1	1	1	1	5	1	1	7	1	1	4	2	1	1	1	1	2	5	1	1	1	1	2	2	1	1
EVMS(L)10 6/2.2	1	1	4	1	1	1	1	6	1	1	9	1	1	4	2	1	1	1	1	2	6	1	1	1	1	2	2	1	1
EVMS(L)10 7/3.0	1	1	5	1	1	1	1	7	1	1	11	1	1	4	2	1	1	1	1	2	7	1	1	1	1	2	2	1	1
EVMS(L)10 8/3.0	1	1	6	1	1	1	1	8	1	1	13	1	1	4	2	1	1	1	1	2	8	1	1	1	1	2	2	1	1
EVMS(L)10 9/4.0	1	1	7	1	1	1	1	9	1	1	15	1	1	4	2	1	1	1	1	2	9	1	1	1	1	2	2	1	1
EVMS(L)10 10/4.0	1	1	8	1	1	1	1	10	1	1	17	1	1	4	2	1	1	1	1	2	10	1	1	1	1	2	2	1	1
EVMS(L)10 11/4.0	1	1	9	1	1	1	1	11	1	1	19	1	1	4	2	1	1	1	1	2	11	1	1	1	1	2	2	1	1
EVMS(L)10 12/5.5	1	1	9	2	1	1	1	12	1	1	19	2	2	4	2	1	1	2	1	2	12	1	1	1	1	2	2	1	1
EVMS(L)10 14/5.5	1	1	11	2	1	1	1	14	1	1	23	2	2	4	2	1	1	2	1	2	14	1	1	1	1	2	2	1	1
EVMS(L)10 15/5.5	1	1	12	2	1	1	1	15	1	1	25	2	2	4	2	1	1	2	1	2	15	1	1	1	1	2	2	1	1
EVMS(L)10 16/7.5	1	1	13	2	1	1	1	16	1	1	27	2	2	4	2	1	1	2	1	2	16	1	1	1	1	2	/	1	1
EVMS(L)10 18/7.5	1	1	15	2	1	1	1	18	1	1	31	2	2	4	2	1	1	2	1	2	18	1	1	1	1	2	/	1	1
EVMS(L)10 19/7.5	1	1	16	2	1	1	1	19	1	1	33	2	2	4	2	1	1	2	1	2	19	1	1	1	1	2	/	1	1
EVMS(L)10 21/7.5	1	1	18	2	1	1	1	21	1	1	37	2	2	4	2	1	1	2	1	2	21	1	1	1	1	2	/	1	1
EVMS(L)10 22/11	1	1	19	2	1	1	1	22	1	1	39	2	2	4	2	1	1	2	1	2	22	1	1	1	1	2	/	1	1
EVMS(L)10 23/11	1	1	19	3	1	1	1	23	1	1	39	3	3	4	2	1	1	3	1	2	23	1	1	1	1	2	/	1	1

Pump Type	N°																								
	120-1	120-3	120-6	120-11*	120-13	128-1	128-3	128-5	128-6	130-1	130-2	131-1	135-1	135-6	137-1	140	160	162	212	212-1	212-2	219*	245	273-1	615**
EVMS(L)10 2/0.75	4	4	4	4	4	4	/	4	4	3	4	1	4	4	1	2	1	1	1	2	1	2	2	2	2
EVMS(L)10 3/1.5	4	4	4	4	4	4	/	4	4	3	4	1	4	4	1	2	1	1	1	2	1	2	2	2	2
EVMS(L)10 4/2.2	4	4	4	4	4	4	/	4	4	3	4	1	4	4	1	2	1	1	1	2	1	2	2	2	2
EVMS(L)10 5/2.2	4	4	4	4	4	4	/	4	4	3	4	1	4	4	1	2	1	1	1	2	1	2	2	2	2
EVMS(L)10 6/2.2	4	4	4	4	4	4	/	4	4	3	4	1	4	4	1	2	1	1	1	2	1	2	2	2	2
EVMS(L)10 7/3.0	4	4	4	4	4	4	/	4	4	3	4	1	4	4	1	2	1	1	1	2	1	2	2	2	2
EVMS(L)10 8/3.0	4	4	4	4	4	4	/	4	4	3	4	1	4	4	1	2	1	1	1	2	1	2	2	2	2
EVMS(L)10 9/4.0	4	4	4	4	4	4	/	4	4	3	4	1	4	4	1	2	1	1	1	2	1	2	2	2	2
EVMS(L)10 10/4.0	4	4	4	4	4	4	/	4	4	3	4	1	4	4	1	2	1	1	1	2	1	2	2	2	2
EVMS(L)10 11/4.0	4	4	4	4	4	4	/	4	4	3	4	1	4	4	1	2	1	1	1	2	1	2	2	2	2
EVMS(L)10 12/5.5	4	4	4	4	4	4	/	3	4	1	4	/	1	2	1	1	1	1	2	1	2	2	2	2	2
EVMS(L)10 14/5.5	4	4	4	4	4	4	/	3	4	1	4	/	1	2	1	1	1	1	2	1	2	2	2	2	2
EVMS(L)10 15/5.5	4	4	4	4	4	4	/	3	4	1	4	/	1	2	1	1	1	1	2	1	2	2	2	2	2
EVMS(L)10 16/7.5	4	4	4	/	4	4	4	/	3	4	1	4	/	1	2	1	1	1	2	1	/	2	2	2	2
EVMS(L)10 18/7.5	4	4	4	/	4	4	4	/	3	4	1	4	/	1	2	1	1	1	2	1	/	2	2	2	2
EVMS(L)10 19/7.5	4	4	4	/	4	4	4	/	3	4	1	4	/	1	2	1	1	1	2	1	/	2	2	2	2
EVMS(L)10 21/7.5	4	4	4	/	4	4	4	/	3	4	1	4	/	1	2	1	1	1	2	1	/	2	2	2	2
EVMS(L)10 22/11	4	4	4	/	4	4	4	/	3	4	1	4	/	1	2	1	1	1	2	1	/	2	2	2	2
EVMS(L)10 23/11	4	4	4	/	4	4	4	/	3	4	1	4	/	1	2	1	1	1	2	1	/	2	2	2	2

* only for Oval flange (N)

** only for Loose round flange (LF)

128-6 / 135-6 : with Aluminium coupling (see drawing pag.211)

PERFORMANCE CURVE
EVMSG10

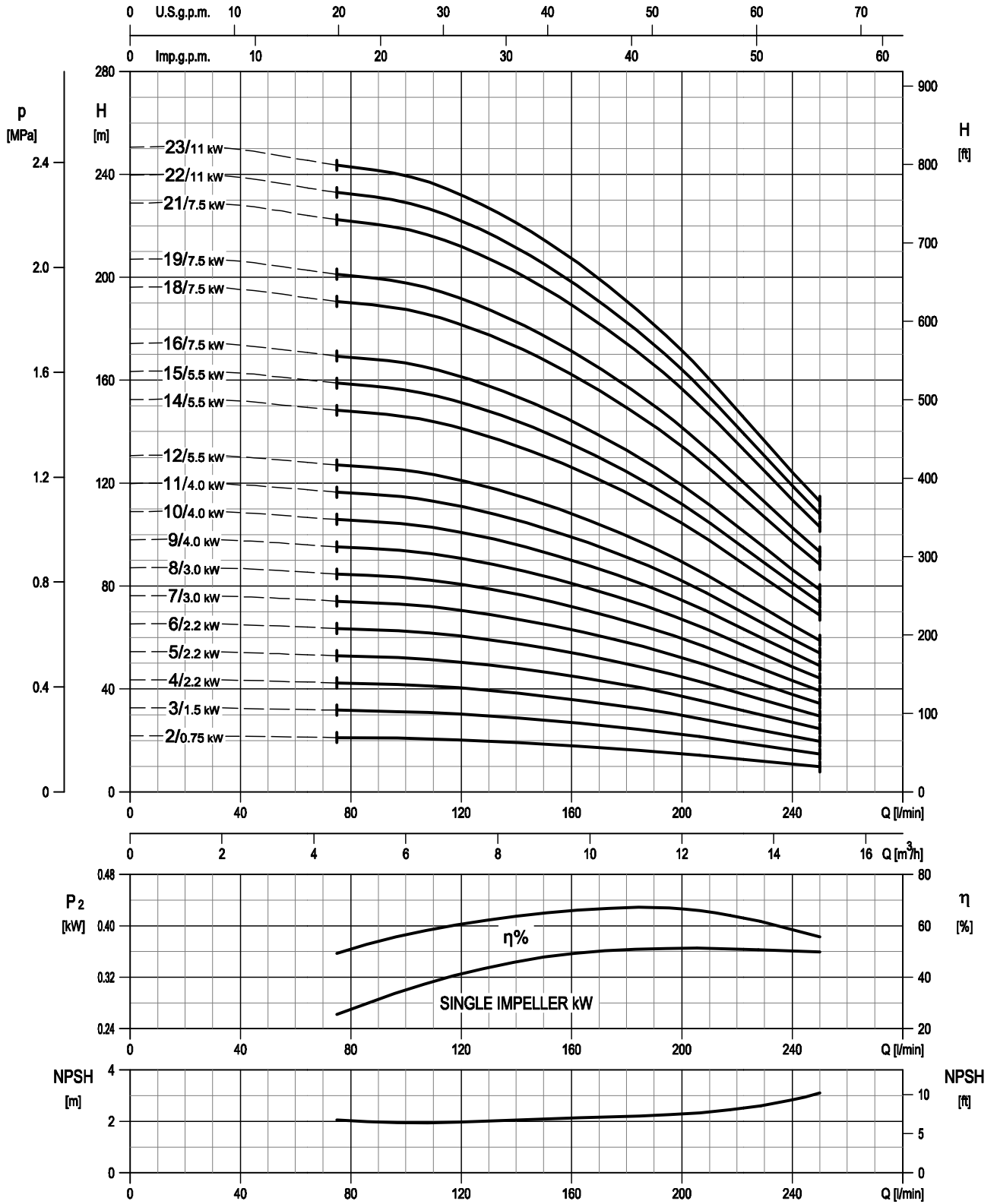

Rotation speed $\approx 2900 \text{ min}^{-1}$
Test standard: ISO 9906:2012 - Grade 3B

TECHNICAL DATA EVMSG10

Dimensional sketch

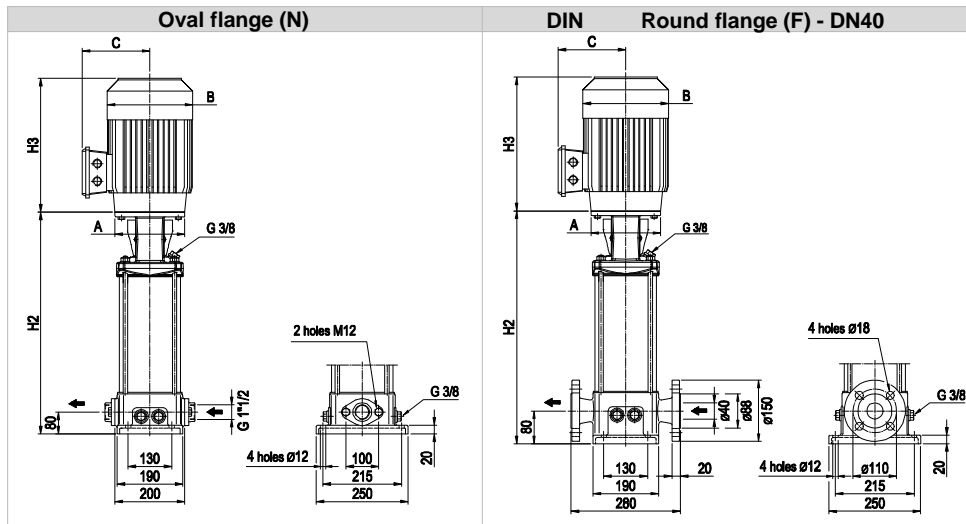

Dimensions [mm] and Weights [Kg]

Pump Type	P _{max} [MPa]	kW	Size	Motor									Oval flange (N)			Round flange (F)				
				A			1 ~			3 ~			H2	Weight Pump	Weight Pump + Motor		H2	Weight Pump	Weight Pump + Motor	
				B	C	H3	B	C	H3	B	C	H3			1 ~	3 ~			1 ~	3 ~
EVMSG10 2/0.75	1.6	0.75	80	ø120	160	151	232	160	139	232	343	21.6	33	31.1	343	24.3	35.7	33.8		
EVMSG10 3/1.5	1.6	1.5	90 S	ø140	172	140	278	180	148	267	383	22.5	40.3	35.2	383	25.3	43.1	38		
EVMSG10 4/2.2	1.6	2.2	90 L	ø140	172	140	278	180	148	267	413	23.3	42.8	39.3	413	26	45.5	42		
EVMSG10 5/2.2	1.6	2.2	90 L	ø140	172	140	278	180	148	267	443	24.2	43.7	40.2	443	26.9	46.4	42.9		
EVMSG10 6/2.2	1.6	2.2	90 L	ø140	172	140	278	180	148	267	473	25	44.5	41	473	27.7	47.2	43.7		
EVMSG10 7/3.0	1.6	3.0	100 L	ø160	-	-	-	196	155	306	513	26	-	48.8	513	28.7	-	51.5		
EVMSG10 8/3.0	1.6	3.0	100 L	ø160	-	-	-	196	155	306	543	26.8	-	49.6	543	29.5	-	52.3		
EVMSG10 9/4.0	1.6	4.0	112 M	ø160	-	-	-	196	155	306	573	27.7	-	54.2	573	30.4	-	56.9		
EVMSG10 10/4.0	1.6	4.0	112 M	ø160	-	-	-	196	155	306	603	28.5	-	55	603	31.2	-	57.7		
EVMSG10 11/4.0	1.6	4.0	112 M	ø160	-	-	-	196	155	306	633	30.1	-	56.6	633	32.9	-	59.4		
EVMSG10 12/5.5	1.6	5.5	132 S	ø300	-	-	-	225	160	328	761	39.9	-	78.5	761	42.7	-	81.3		
EVMSG10 14/5.5	1.6	5.5	132 S	ø300	-	-	-	225	160	328	821	41.8	-	80.4	821	44.5	-	83.1		
EVMSG10 15/5.5	1.6	5.5	132 S	ø300	-	-	-	225	160	328	851	42.7	-	81.3	851	45.4	-	84		
EVMSG10 16/7.5	2.5	7.5	132 S	ø300	-	-	-	225	160	350	-	-	-	-	881	46.3	-	86.7		
EVMSG10 18/7.5	2.5	7.5	132 S	ø300	-	-	-	225	160	350	-	-	-	-	941	47.7	-	88.1		
EVMSG10 19/7.5	2.5	7.5	132 S	ø300	-	-	-	225	160	350	-	-	-	-	971	49.1	-	89.5		
EVMSG10 21/7.5	2.5	7.5	132 S	ø300	-	-	-	225	160	350	-	-	-	-	1031	50.9	-	91.3		
EVMSG10 22/11	2.5	11	160 M	ø350	-	-	-	248	194	476	-	-	-	-	1091	53.2	-	115.7		
EVMSG10 23/11	2.5	11	160 M	ø350	-	-	-	248	194	476	-	-	-	-	1121	59.9	-	122.4		

1.6 MPa=16 bar ; 2.5 MPa=25 bar
- not available model

SECTIONAL VIEW
EVMSG10

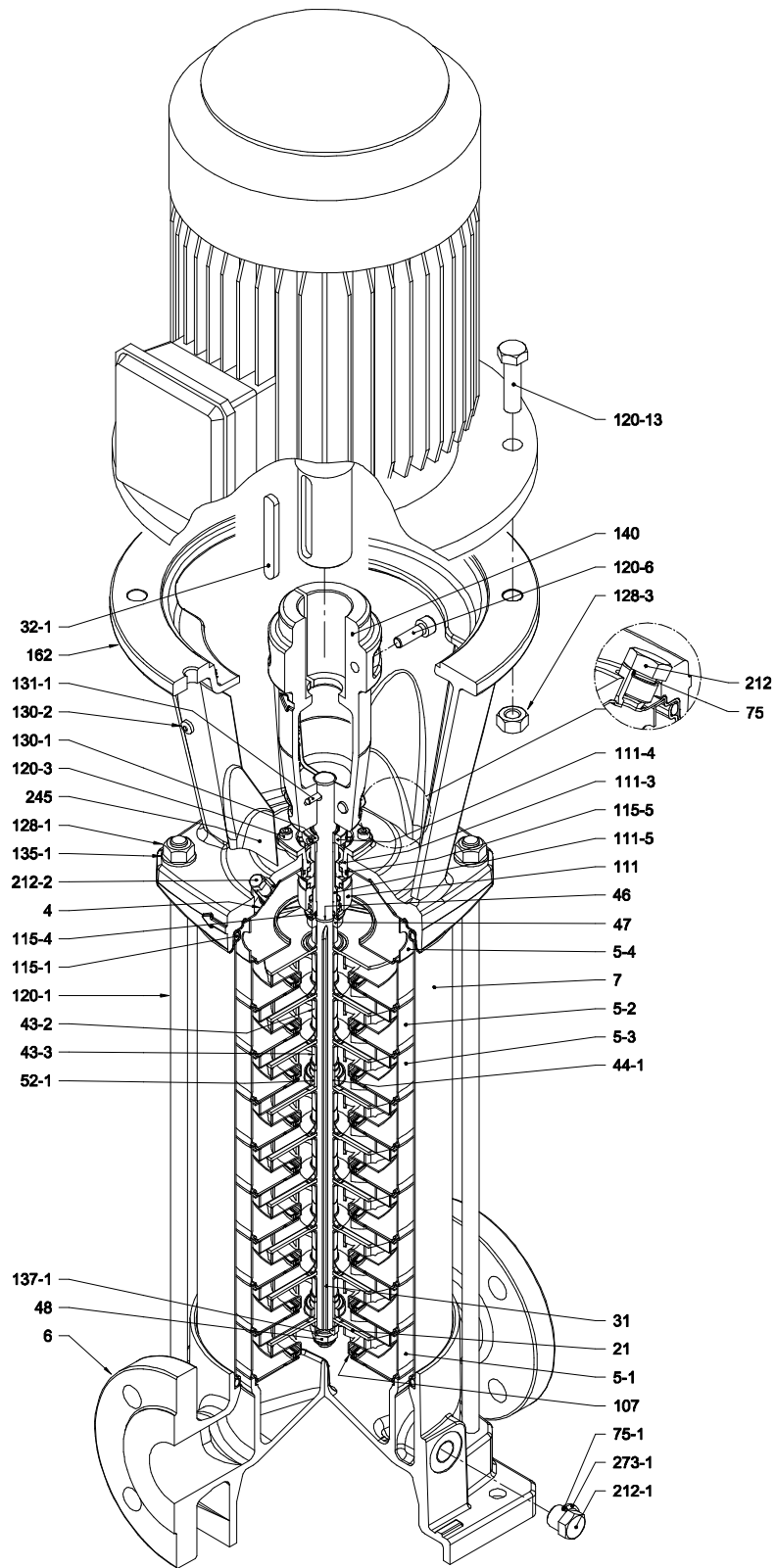

with Round flange (F)

PIPE CONNECTION EVMSG10

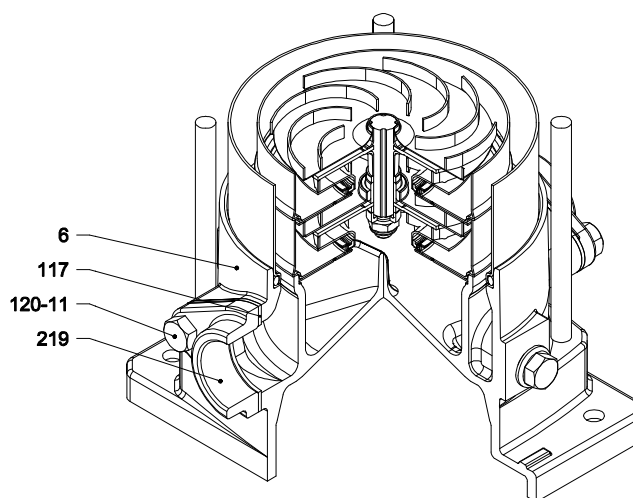

with Oval flange (N)

EVMSG10

SECTIONAL TABLE
EVMSG10

N°	PART NAME	MATERIAL EVMSG	DIMENSIONS	STANDARD	
4	Casing cover	EN 1.4301 (AISI 304)			
5-1	Suction casing	EN 1.4301 (AISI 304)			
5-2	Intermediate Casing	EN 1.4301 (AISI 304)			
5-3	Intermediate casing bearing	EN 1.4301 (AISI 304)			
5-4	Discharge casing	EN 1.4301 (AISI 304)			
6	Bottom casing	Cast Iron EN G.JL-250-EN1561			
7	Outer casing	EN 1.4301 (AISI 304)			
21	Impeller	EN 1.4301 (AISI 304)			
31	Shaft	EN 1.4301 (AISI 304)			
32-1	Adjuster Key	EN 1.4301 (AISI 304)			
43-2	Shaft sleeve (intermediate)	EN 1.4301 (AISI 304)			
43-3	Shaft sleeve (bearing)	EN 1.4301 (AISI 304)			
44-1	Shaft sleeve bearing	Tungsten carbide			
46	Ring (mechanical seal)	EN 1.4404 (AISI 316L)			
47	Ring Holder	EN 1.4301 (AISI 304)			
48	Impeller nut	A2-70 UNI 7323 with inox insert	M10		
52-1	Bearing	Tungsten carbide			
75	O-Ring (plug)	EPDM	D. 12.37x2.62	OR 3050	
75-1	O-Ring (plug)	EPDM			
107	Liner ring	EN 1.4301 (AISI 304) + PPS			
111	Mechanical Seal	SiC/Carbon/EPDM			
111-3	Mechanical seal seat	EN 1.4301 (AISI 304)			
111-4	Seal holder	EN 1.4301 (AISI 304)			
111-5	Mechanical seal cartridge	EN 1.4301 (AISI 304)			
115-1	O-Ring (outer casing)	EPDM	D. 164,46x5,34	OR 6645	
115-4	O-Ring (cartridge sleeve)	EPDM	D. 15.88x2.62	OR 121	
115-5	O-Ring (seal cover)	EPDM	D. 37.77x2.62	OR 3150	
117	Flange gasket	EPDM			
120-1	Tie-rod	Galvanized steel 6.8 strength class ISO 898/1	M12		
120-3	Screw	A2-70 UNI 7323	M5x12	ISO 4762	
120-6	Screw for coupling	Galvanized steel	up to 4.0 kW	M6x25	ISO 4762
			from 5.5 kW to 7.5 kW	M8x20	ISO 4762
			above 11 kW	M10x30	ISO 4762
120-11	Screw for counterflange	A2-70 UNI 7323			
120-13	Screw for motor	Galvanized steel 8.8 strength class ISO 898/1	MEC 80	M6x20	ISO 4017
			MEC 90-100-112	M8x20	ISO 4017
			MEC 132	M12x40	UNI 5739
			MEC 160	M16x50	ISO 4017
128-1	Nut for tie rod	Galvanized steel	M12	UNI 5588	
128-3	Nut (motor)	Galvanized steel	M12	UNI 5588	
			M16	ISO 4032	
130-1	Set screw	A2-70 UNI 7323	M5x8	UNI 5923	
130-2	Screw for coupling guard	A2-70 UNI 7323	M5x6	UNI 7687	
131-1	Pin for shaft	Carbon Steel	D. 5x35	UNI 4838	
135-1	Washer	Galvanized steel	D. 13x24x2,5	UNI 6592	
137-1	Impeller spacer	EN 1.4301 (AISI 304)			
140	Coupling	up to 4.0 kW	Die cast Aluminium EN AB-AISI11Cu2 (Fe)		
		above 5.5 kW	Cast Iron		
162	Motor bracket	Cast iron EN-GJL-200-EN 1561			
212	Plug	EN 1.4301 (AISI 304)	G 3/8		
212-1	Plug	EN 1.4301 (AISI 304)	G 3/8		
212-2	Venting plug	EN 1.4404 (AISI 316L)			
219	Counter flange	Galvanized steel			
245	Coupling guard	EN 1.4301 (AISI 304)			
273-1	Plug Washer	EN 1.4301 (AISI 304)			

QUANTITY FOR MODEL EVMSG10

Pump Type	N°																										
	4	5-1	5-2	5-3	5-4	6	7	21	31	32-1	43-2	43-3	44-1	46	47	48	52-1	75	75-1	107	111	111-3	111-4	111-5	115-1	115-4	115-5
EVMSG10 2/0.75	1	1	/	1	1	1	1	2	1	1	/	1	1	2	1	1	1	1	4	2	1	1	1	1	2	1	1
EVMSG10 3/1.5	1	1	1	1	1	1	1	3	1	1	3	1	1	2	1	1	1	1	4	3	1	1	1	1	2	1	1
EVMSG10 4/2.2	1	1	2	1	1	1	1	4	1	1	5	1	1	2	1	1	1	1	4	4	1	1	1	1	2	1	1
EVMSG10 5/2.2	1	1	3	1	1	1	1	5	1	1	7	1	1	2	1	1	1	1	4	5	1	1	1	1	2	1	1
EVMSG10 6/2.2	1	1	4	1	1	1	1	6	1	1	9	1	1	2	1	1	1	1	4	6	1	1	1	1	2	1	1
EVMSG10 7/3.0	1	1	5	1	1	1	1	7	1	1	11	1	1	2	1	1	1	1	4	7	1	1	1	1	2	1	1
EVMSG10 8/3.0	1	1	6	1	1	1	1	8	1	1	13	1	1	2	1	1	1	1	4	8	1	1	1	1	2	1	1
EVMSG10 9/4.0	1	1	7	1	1	1	1	9	1	1	15	1	1	2	1	1	1	1	4	9	1	1	1	1	2	1	1
EVMSG10 10/4.0	1	1	8	1	1	1	1	10	1	1	17	1	1	2	1	1	1	1	4	10	1	1	1	1	2	1	1
EVMSG10 11/4.0	1	1	9	1	1	1	1	11	1	1	19	1	1	2	1	1	1	1	4	11	1	1	1	1	2	1	1
EVMSG10 12/5.5	1	1	9	2	1	1	1	12	1	1	19	2	2	2	1	1	2	1	4	12	1	1	1	1	2	1	1
EVMSG10 14/5.5	1	1	11	2	1	1	1	14	1	1	23	2	2	2	1	1	2	1	4	14	1	1	1	1	2	1	1
EVMSG10 15/5.5	1	1	12	2	1	1	1	15	1	1	25	2	2	2	1	1	2	1	4	15	1	1	1	1	2	1	1
EVMSG10 16/7.5	1	1	13	2	1	1	1	16	1	1	27	2	2	2	1	1	2	1	4	16	1	1	1	1	2	1	1
EVMSG10 18/7.5	1	1	15	2	1	1	1	18	1	1	31	2	2	2	1	1	2	1	4	18	1	1	1	1	2	1	1
EVMSG10 19/7.5	1	1	16	2	1	1	1	19	1	1	33	2	2	2	1	1	2	1	4	19	1	1	1	1	2	1	1
EVMSG10 21/7.5	1	1	18	2	1	1	1	21	1	1	37	2	2	2	1	1	2	1	4	21	1	1	1	1	2	1	1
EVMSG10 22/11	1	1	19	2	1	1	1	22	1	1	39	2	2	2	1	1	2	1	4	22	1	1	1	1	2	1	1
EVMSG10 23/11	1	1	19	3	1	1	1	23	1	1	39	3	3	2	1	1	3	1	4	23	1	1	1	1	2	1	1

Pump Type	N°																						
	117*	120-1	120-3	120-6	120-11*	120-13	128-1	128-3	128-6	130-1	130-2	131-1	135-1	135-6	137-1	140	162	212	212-1	212-2	219*	245	273-1
EVMSG10 2/0.75	2	4	4	4	4	4	4	/	4	3	4	1	4	4	1	2	1	1	4	1	2	2	4
EVMSG10 3/1.5	2	4	4	4	4	4	4	/	4	3	4	1	4	4	1	2	1	1	4	1	2	2	4
EVMSG10 4/2.2	2	4	4	4	4	4	4	/	4	3	4	1	4	4	1	2	1	1	4	1	2	2	4
EVMSG10 5/2.2	2	4	4	4	4	4	4	/	4	3	4	1	4	4	1	2	1	1	4	1	2	2	4
EVMSG10 6/2.2	2	4	4	4	4	4	4	/	4	3	4	1	4	4	1	2	1	1	4	1	2	2	4
EVMSG10 7/3.0	2	4	4	4	4	4	4	/	4	3	4	1	4	4	1	2	1	1	4	1	2	2	4
EVMSG10 8/3.0	2	4	4	4	4	4	4	/	4	3	4	1	4	4	1	2	1	1	4	1	2	2	4
EVMSG10 9/4.0	2	4	4	4	4	4	4	/	4	3	4	1	4	4	1	2	1	1	4	1	2	2	4
EVMSG10 10/4.0	2	4	4	4	4	4	4	/	4	3	4	1	4	4	1	2	1	1	4	1	2	2	4
EVMSG10 11/4.0	2	4	4	4	4	4	4	/	4	3	4	1	4	4	1	2	1	1	4	1	2	2	4
EVMSG10 12/5.5	2	4	4	4	4	4	4	/	3	4	1	4	/	1	2	1	1	4	1	2	2	4	
EVMSG10 14/5.5	2	4	4	4	4	4	4	/	3	4	1	4	/	1	2	1	1	4	1	2	2	4	
EVMSG10 15/5.5	2	4	4	4	4	4	4	/	3	4	1	4	/	1	2	1	1	4	1	2	2	4	
EVMSG10 16/7.5	/	4	4	4	/	4	4	4	/	3	4	1	4	/	1	2	1	1	4	1	/	2	4
EVMSG10 18/7.5	/	4	4	4	/	4	4	4	/	3	4	1	4	/	1	2	1	1	4	1	/	2	4
EVMSG10 19/7.5	/	4	4	4	/	4	4	4	/	3	4	1	4	/	1	2	1	1	4	1	/	2	4
EVMSG10 21/7.5	/	4	4	4	/	4	4	4	/	3	4	1	4	/	1	2	1	1	4	1	/	2	4
EVMSG10 22/11	/	4	4	4	/	4	4	4	/	3	4	1	4	/	1	2	1	1	4	1	/	2	4
EVMSG10 23/11	/	4	4	4	/	4	4	4	/	3	4	1	4	/	1	2	1	1	4	1	/	2	4

* only for Oval flange (N)
128-6 / 135-6 : with Aluminium coupling (see drawing pag.211)

PERFORMANCE CURVE
EVMS(L)15

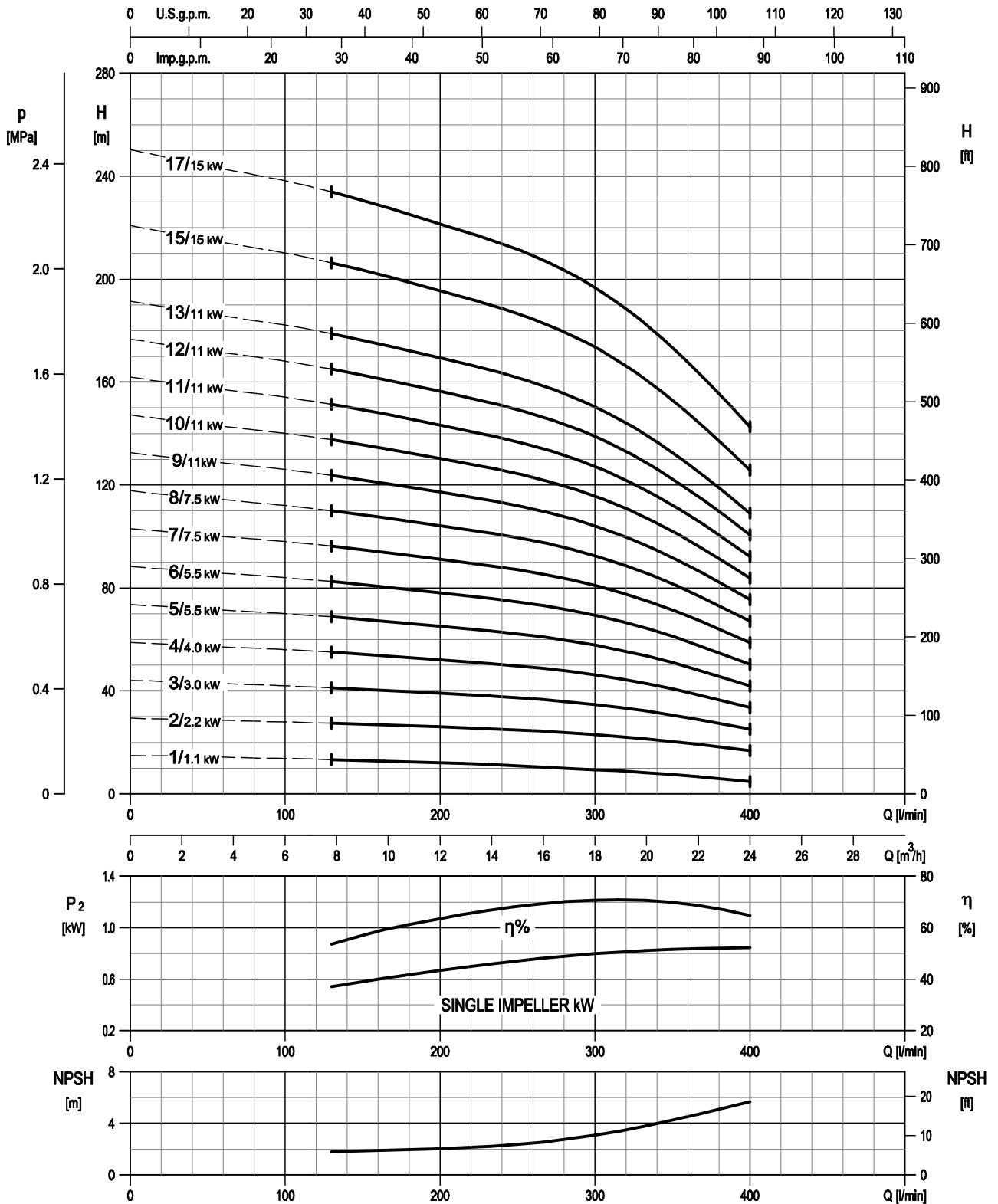

Rotation speed $\approx 2900 \text{ min}^{-1}$
Test standard: ISO 9906:2012 - Grade 3B

TECHNICAL DATA EVMS(L)15

Dimensional sketch

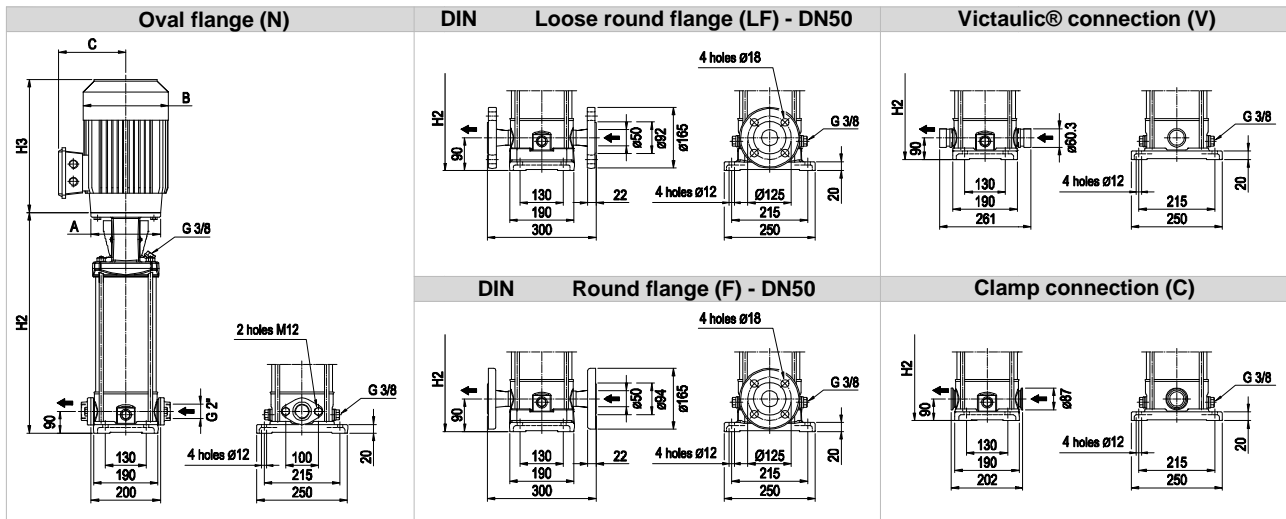

Dimensions [mm] and Weights [Kg]

Pump Type	Pmax [MPa]	kW	Motor									Oval flange (N)			Loose round flange (LF) Round flange (F)			Victaalic® connection (V) Clamp connection (C)						
			Size	A			1 ~			3 ~			H2	Weight Pump	Weight Pump + Motor		H2	Weight Pump	Weight Pump + Motor		H2	Weight Pump	Weight Pump + Motor	
				B	C	H3	B	C	H3	B	C	H3			1 ~	3 ~			1 ~	3 ~			1 ~	3 ~
EVMS(L)15 1/1.1	1.6	1.1	80	120	160	151	232	160	139	232	377	18	29.8	29.1	377	18.8	30.6	29.9	377	16.9	28.7	28		
EVMS(L)15 2/2.2	1.6	2.2	90L	140	172	140	278	180	148	267	387	18.3	37.8	34.3	387	19.1	38.6	35.1	387	17.2	36.7	33.2		
EVMS(L)15 3/3.0	1.6	3.0	100 L	160	-	-	-	196	155	306	437	19.6	-	42.4	437	20.4	-	43.2	437	18.5	-	41.3		
EVMS(L)15 4/4.0	1.6	4.0	112 M	160	-	-	-	196	155	306	477	20.8	-	47.3	477	21.6	-	48.1	477	19.7	-	46.2		
EVMS(L)15 5/5.5	1.6	5.5	132 S	300	-	-	-	225	160	328	614	30.5	-	69.1	614	31.3	-	69.9	614	29.4	-	68		
EVMS(L)15 6/5.5	1.6	5.5	132 S	300	-	-	-	225	160	328	654	31.7	-	70.3	654	32.5	-	71.1	654	30.6	-	69.2		
EVMS(L)15 7/7.5	1.6	7.5	132 S	300	-	-	-	225	160	350	694	33.9	-	74.3	694	34.7	-	75.1	694	32.8	-	73.2		
EVMS(L)15 8/7.5	1.6	7.5	132 S	300	-	-	-	225	160	350	734	35.2	-	75.6	734	36	-	76.4	734	34.1	-	74.5		
EVMS(L)15 9/11	1.6	11	160 M	350	-	-	-	248	194	476	804	36.5	-	99	804	37.3	-	99.8	804	35.4	-	97.9		
EVMS(L)15 10/11	1.6	11	160 M	350	-	-	-	248	194	476	844	37.8	-	100.3	844	38.6	-	101.1	844	36.7	-	99.2		
EVMS(L)15 11/11	1.6	11	160 M	350	-	-	-	248	194	476	884	45.8	-	108.3	884	46.6	-	109.1	884	44.7	-	107.2		
EVMS(L)15 12/11	2.5	11	160 M	350	-	-	-	248	194	476	-	-	-	-	924	47.9	-	110.4	924	46	-	108.5		
EVMS(L)15 13/11	2.5	11	160 M	350	-	-	-	248	194	476	-	-	-	-	964	49.2	-	111.7	964	47.3	-	109.8		
EVMS(L)15 15/15	2.5	15	160 M	350	-	-	-	317	238	498	-	-	-	-	1044	51.8	-	140.7	1044	49.9	-	138.8		
EVMS(L)15 17/15	2.5	15	160 M	350	-	-	-	317	238	498	-	-	-	-	1124	54.7	-	143.6	1124	52.8	-	141.7		

1.6 MPa=16 bar ; 2.5 MPa=25 bar
- not available model

SECTIONAL VIEW
EVMS(L)15

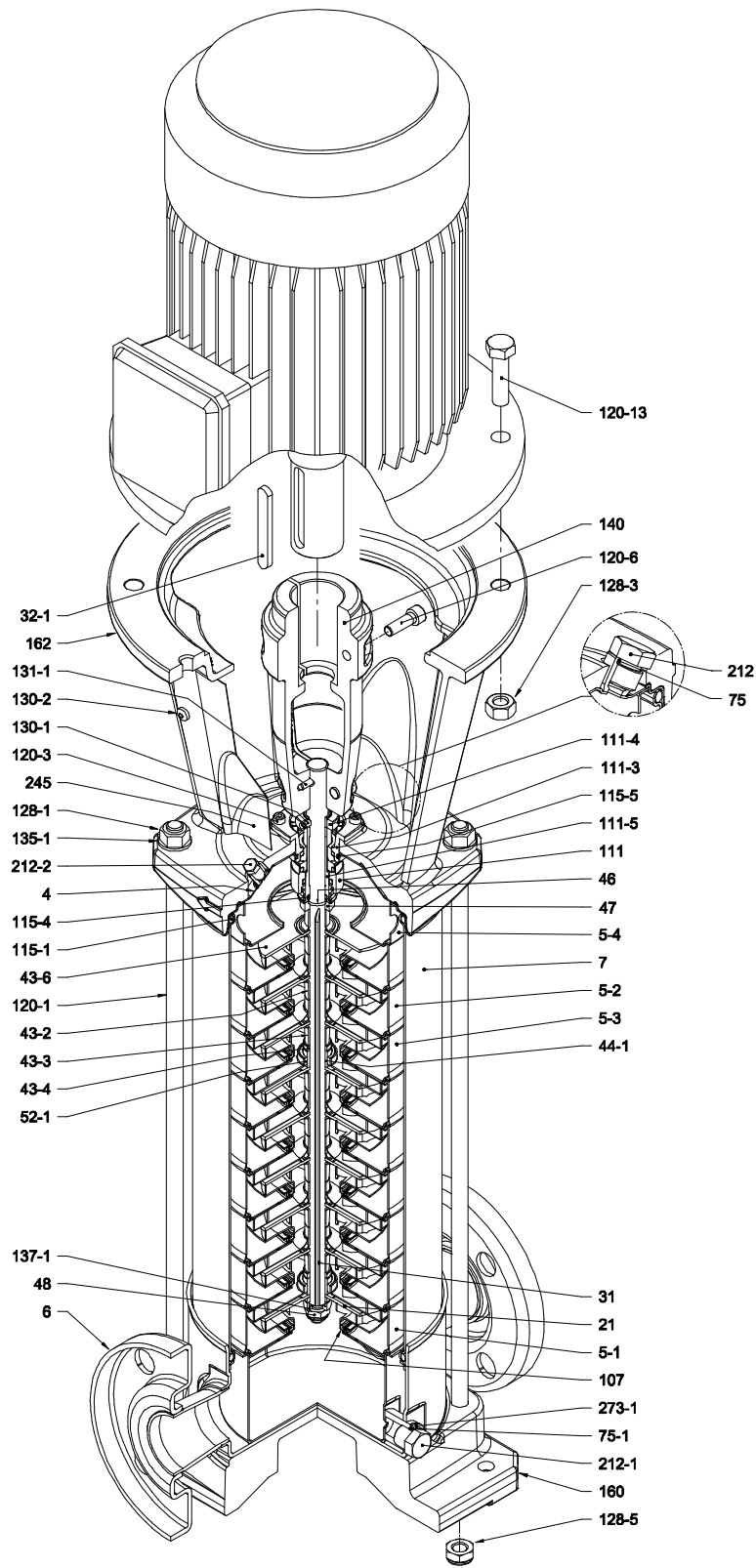

with Round flange (F)

PIPE CONNECTION EVMS(L)15

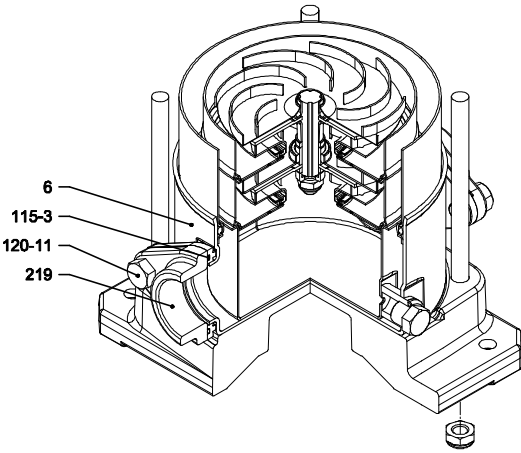

with Oval flange (N)

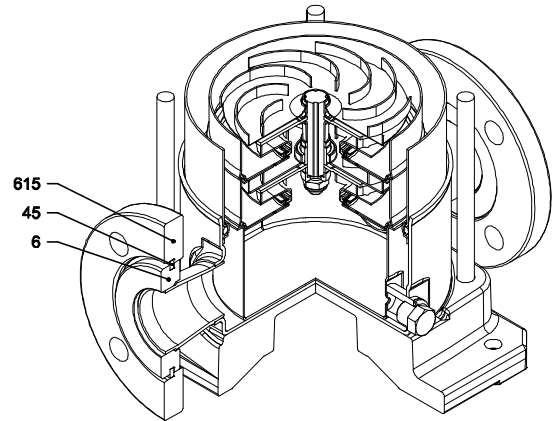

with Loose round flange (LF)

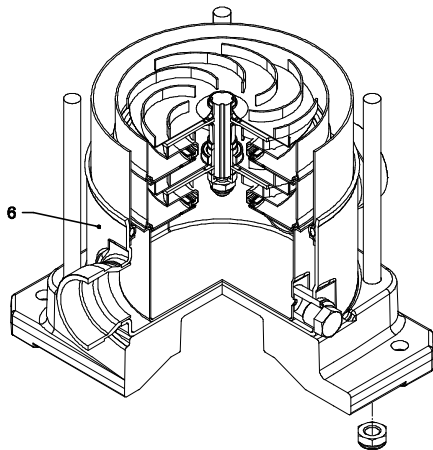

with Victaulic® connection (V)

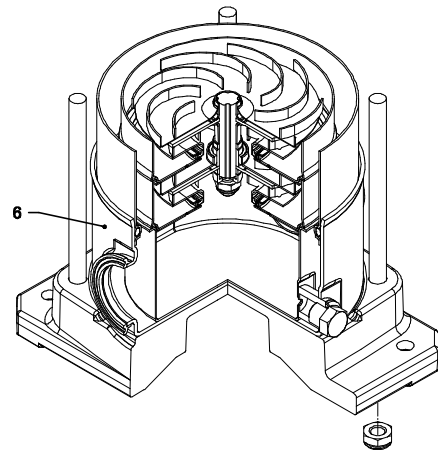

with Clamp connection (C)

SECTIONAL TABLE
EVMS(L)15

N°	PART NAME	MATERIAL		DIMENSIONS	STANDARD
		EVMS	EVMSL		
4	Casing cover	EN 1.4301 (AISI 304)	EN 1.4401 (AISI 316)		
5-1	Suction casing	EN 1.4301 (AISI 304)	EN 1.4401 (AISI 316)		
5-2	Intermediate Casing	EN 1.4301 (AISI 304)	EN 1.4401 (AISI 316)		
5-3	Intermediate casing bearing	EN 1.4301 (AISI 304)	EN 1.4401 (AISI 316)		
5-4	Discharge casing	EN 1.4301 (AISI 304)	EN 1.4401 (AISI 316)		
6	Bottom casing	EN 1.4301 (AISI 304)	EN 1.4401 (AISI 316)		
7	Outer casing	EN 1.4301 (AISI 304)	EN 1.4404 (AISI 316L)		
21	Impeller	EN 1.4301 (AISI 304)	EN 1.4401 (AISI 316)		
31	Shaft	EN 1.4301 (AISI 304) - EN 1.4462 (AISI 329A)	EN 1.4404 (AISI 316L) - EN 1.4462 (AISI 329A)		
32-1	Adjuster Key	EN 1.4301 (AISI 304)			
43-2	Shaft sleeve (intermediate)	EN 1.4301 (AISI 304)	EN 1.4404 (AISI 316L)		
43-3	Shaft sleeve (bearing)	EN 1.4301 (AISI 304)	EN 1.4401 (AISI 316)		
43-4	Shaft sleeve (adjustment)	EN 1.4301 (AISI 304)	EN 1.4401 (AISI 316)		
43-6	Washer	EN 1.4404 (AISI 316L)		D. 26x2,5	
44-1	Shaft sleeve bearing	Tungsten carbide			
45	Flange holder	EN 1.4301 (AISI 304)			
46	Ring (mechanical seal)	EN 1.4404 (AISI 316L)			
47	Ring Holder	EN 1.4301 (AISI 304)	EN 1.4401 (AISI 316)		
48	Impeller nut	A2-70 UNI 7323 with inox insert	A4-70 UNI 7323 with inox insert	M10	
52-1	Bearing	Tungsten carbide			
75	O-Ring (plug)	EPDM		D. 12.37x2.62	OR 3050
75-1	O-Ring (plug)	EPDM			
107	Liner ring	EN 1.4301 (AISI 304) + PPS	EN 1.4401 (AISI 316) + PPS		
111	Mechanical Seal	SiC/Carbon/EPDM			
111-3	Mechanical seal seat	EN 1.4301 (AISI 304)	EN 1.4401 (AISI 316)		
111-4	Seal holder	EN 1.4301 (AISI 304)			
111-5	Mechanical seal cartridge	EN 1.4301 (AISI 304)	EN 1.4401 (AISI 316)		
115-1	O-Ring (outer casing)	EPDM		D. 164.46x5.34	OR 6645
115-3	O-Ring	EPDM			
115-4	O-Ring (cartridge sleeve)	EPDM		D. 15.88x2.62	OR 121
115-5	O-Ring (seal cover)	EPDM		D. 37.77x2.62	OR 3150
120-1	Tie-rod	Galvanized steel 6.8 strength class ISO 898/1		M12	
120-3	Screw	A2-70 UNI 7323		M5x12	ISO 4762
120-6	Screw for coupling	up to 4.0 kW from 5.5 kW to 7.5 kW above 11 kW	Galvanized steel	M6x25	ISO 4762
				M8x20	ISO 4762
				M10x30	ISO 4762
120-11	Screw for counterflange	A2-70 UNI 7323			
120-13	Screw for motor	MEC 80 MEC 90-100-112 MEC 132 MEC 160	Galvanized steel 8.8 strength class ISO 898/1	M6x20	ISO 4017
				M8x20	ISO 4017
				M12x40	UNI 5739
				M16x50	ISO 4017
128-1	Nut for tie rod	Galvanized steel		M12	UNI 5588
128-3	Nut (motor)	MEC 132 MEC 160	Galvanized steel	M12	UNI 5588
				M16	ISO 4032
128-5	Nut for tie rod	Galvanized steel		M12	UNI 7474
130-1	Set screw	A2-70 UNI 7323		M5x8	UNI 5923
130-2	Screw for coupling guard	A2-70 UNI 7323		M5x6	UNI 7687
131-1	Pin for shaft	Carbon Steel		D.5x35	UNI 4838
135-1	Washer	Galvanized steel		D. 13x24x2,5	UNI 6592
137-1	Impeller spacer	EN 1.4301 (AISI 304)	EN 1.4401 (AISI 316)		
140	Coupling	up to 4.0 kW above 5.5 kW	Die cast Aluminium EN AB-AISI11Cu2 (Fe)		
160	Base	Cast Iron			
162	Motor bracket	Die cast Aluminium EN AB-AISI11Cu2 (Fe)			
212	Plug	Cast iron EN-GJL-200-EN 1561			
212	Plug	EN 1.4301 (AISI 304)	EN 1.4401 (AISI 316)	G 3/8	
212-1	Plug	EN 1.4301 (AISI 304)	EN 1.4401 (AISI 316)	G 3/8	
212-2	Venting plug	EN 1.4404 (AISI 316L)			
219	Counter flange	EN 1.4301 (AISI 304)	EN 1.4401 (AISI 316)		
245	Coupling guard	EN 1.4301 (AISI 304)			
273-1	Plug Washer	EN 1.4301 (AISI 304)	EN 1.4401 (AISI 316)		
615	Flange	Carbon steel			

QUANTITY FOR MODEL EVMS(L)15

Pump Type	N°																														
	4	5-1	5-2	5-3	5-4	6	7	21	31***	32-1	43-2	43-3	43-4	43-6	44-1	45**	46	47	48	52-1	75	75-1	107	111	111-3	111-4	111-5	115-1	115-3*	115-4	115-5
EVMS(L)15 1/1.1	1	1	/	1	1	1	1	1	1	/	1	1	1	1	4	2	1	1	1	1	2	1	1	1	1	1	1	2	2	1	1
EVMS(L)15 2/2.2	1	1	/	1	1	1	1	2	1	/	1	1	/	1	4	2	1	1	1	1	2	2	1	1	1	1	1	2	2	1	1
EVMS(L)15 3/3.0	1	1	1	1	1	1	1	3	1	1	3	1	1	/	1	4	2	1	1	1	1	2	3	1	1	1	1	2	2	1	1
EVMS(L)15 4/4.0	1	1	2	1	1	1	1	4	1	1	5	1	1	/	1	4	2	1	1	1	1	2	4	1	1	1	1	2	2	1	1
EVMS(L)15 5/5.5	1	1	3	1	1	1	1	5	1	1	7	1	1	/	1	4	2	1	1	1	1	2	5	1	1	1	1	2	2	1	1
EVMS(L)15 6/5.5	1	1	4	1	1	1	1	6	1	1	9	1	1	/	1	4	2	1	1	1	1	2	6	1	1	1	1	2	2	1	1
EVMS(L)15 7/7.5	1	1	4	2	1	1	1	7	1	1	9	2	2	/	2	4	2	1	1	2	1	2	7	1	1	1	1	2	2	1	1
EVMS(L)15 8/7.5	1	1	5	2	1	1	1	8	1	1	11	2	2	/	2	4	2	1	1	2	1	2	8	1	1	1	1	2	2	1	1
EVMS(L)15 9/11	1	1	6	2	1	1	1	9	1	1	13	2	2	/	2	4	2	1	1	2	1	2	9	1	1	1	1	2	2	1	1
EVMS(L)15 10/11	1	1	7	2	1	1	1	10	1	1	15	1	2	/	2	4	2	1	1	2	1	2	10	1	1	1	1	2	2	1	1
EVMS(L)15 11/11	1	1	8	2	1	1	1	11	1	1	17	1	2	/	2	4	2	1	1	2	1	2	11	1	1	1	1	2	2	1	1
EVMS(L)15 12/11	1	1	9	2	1	1	1	12	1	1	19	1	2	/	2	4	2	1	1	2	1	2	12	1	1	1	1	2	/	1	1
EVMS(L)15 13/11	1	1	10	2	1	1	1	13	1	1	21	1	2	/	2	4	2	1	1	2	1	2	13	1	1	1	1	2	/	1	1
EVMS(L)15 15/15	1	1	12	2	1	1	1	15	1	1	25	1	2	/	2	4	2	1	1	2	1	2	15	1	1	1	1	2	/	1	1
EVMS(L)15 17/15	1	1	13	3	1	1	1	17	1	1	27	2	2	/	3	4	2	1	1	3	1	2	17	1	1	1	1	2	/	1	1

Pump Type	N°																								
	120-1	120-3	120-6	120-11*	120-13	128-1	128-3	128-5	128-6	130-1	130-2	131-1	135-1	135-6	137-1	140	160	162	212	212-1	212-2	219*	245	273-1	615**
EVMS(L)15 1/1.1	4	4	4	4	4	4	/	4	4	3	4	1	4	4	1	2	1	1	1	2	1	2	2	2	2
EVMS(L)15 2/2.2	4	4	4	4	4	4	/	4	4	3	4	1	4	4	1	2	1	1	1	2	1	2	2	2	2
EVMS(L)15 3/3.0	4	4	4	4	4	4	/	4	4	3	4	1	4	4	1	2	1	1	1	2	1	2	2	2	2
EVMS(L)15 4/4.0	4	4	4	4	4	4	/	4	4	3	4	1	4	4	1	2	1	1	1	2	1	2	2	2	2
EVMS(L)15 5/5.5	4	4	4	4	4	4	4	4	4	3	4	1	4	/	1	2	1	1	1	2	1	2	2	2	2
EVMS(L)15 6/5.5	4	4	4	4	4	4	4	4	4	3	4	1	4	/	1	2	1	1	1	2	1	2	2	2	2
EVMS(L)15 7/7.5	4	4	4	4	4	4	4	4	4	3	4	1	4	/	1	2	1	1	1	2	1	2	2	2	2
EVMS(L)15 8/7.5	4	4	4	4	4	4	4	4	4	3	4	1	4	/	1	2	1	1	1	2	1	2	2	2	2
EVMS(L)15 9/11	4	4	4	4	4	4	4	4	4	3	4	1	4	/	1	2	1	1	1	2	1	2	2	2	2
EVMS(L)15 10/11	4	4	4	4	4	4	4	4	4	3	4	1	4	/	1	2	1	1	1	2	1	2	2	2	2
EVMS(L)15 11/11	4	4	4	4	4	4	4	4	4	3	4	1	4	/	1	2	1	1	1	2	1	2	2	2	2
EVMS(L)15 12/11	4	4	4	/	4	4	4	4	4	3	4	1	4	/	1	2	1	1	1	2	1	/	2	2	2
EVMS(L)15 13/11	4	4	4	/	4	4	4	4	4	3	4	1	4	/	1	2	1	1	1	2	1	/	2	2	2
EVMS(L)15 15/15	4	4	4	/	4	4	4	4	4	3	4	1	4	/	1	2	1	1	1	2	1	/	2	2	2
EVMS(L)15 17/15	4	4	4	/	4	4	4	4	4	3	4	1	4	/	1	2	1	1	1	2	1	/	2	2	2

* only for Oval flange (N)

** only for Loose round flange (LF)

*** shaft in EN 1.4462 (AISI 329A)

128-6 / 135-6 : with Aluminium coupling (see drawing pag.211)

PERFORMANCE CURVE
EVMSG15

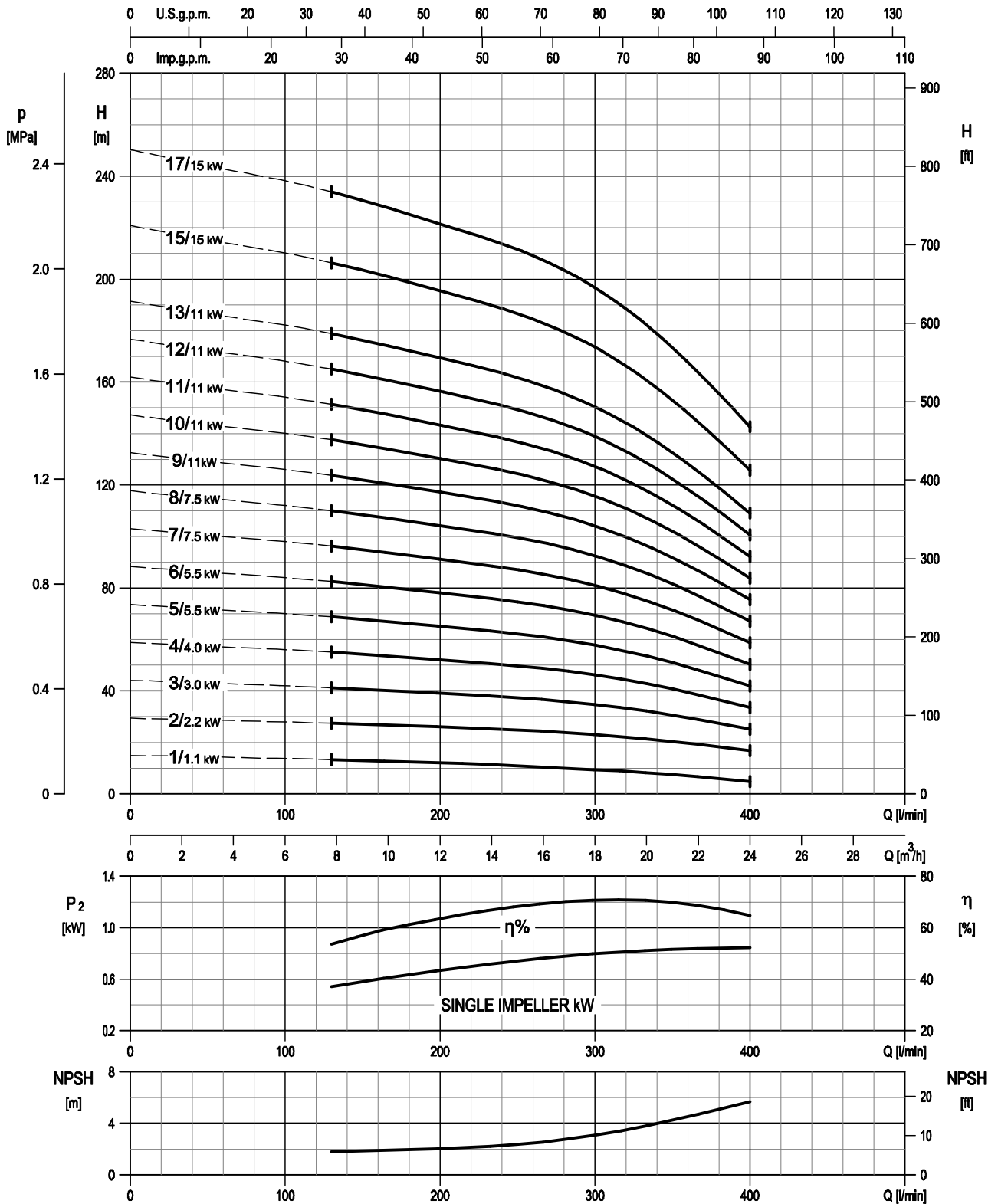

Rotation speed $\approx 2900 \text{ min}^{-1}$
Test standard: ISO 9906:2012 - Grade 3B

TECHNICAL DATA EVMSG15

Dimensional sketch

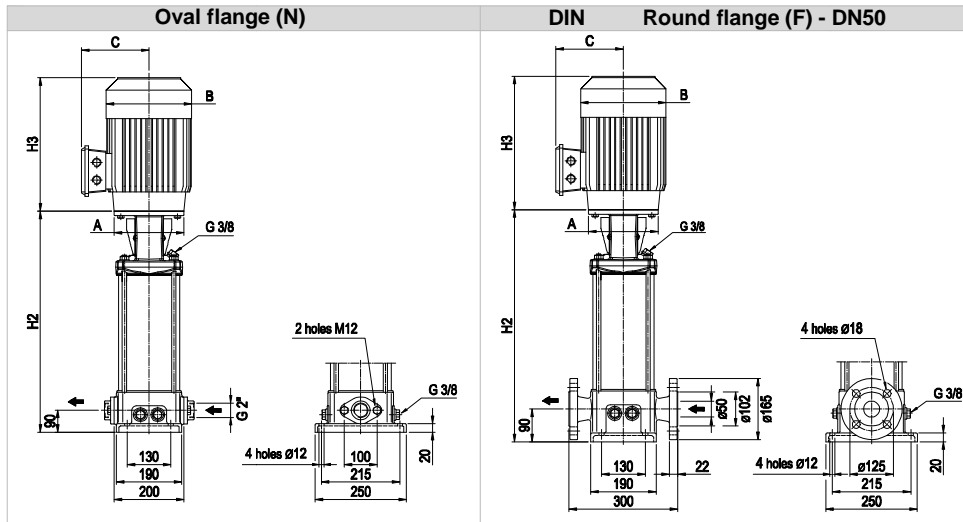

Dimensions [mm] and Weights [Kg]

Pump Type	P _{max} [MPa]	kW	Size	Motor									Oval flange (N)			Round flange (F)				
				A			1 ~			3 ~			H2	Weight Pump	Weight Pump + Motor		H2	Weight Pump	Weight Pump + Motor	
				B	C	H3	B	C	H3	B	C	H3			1 ~	3 ~			1 ~	3 ~
EVMSG15 1/1.1	1.6	1.1	80	ø120	160	151	232	160	139	232	377	22.4	34.2	33.5	377	26.9	38.7	38		
EVMSG15 2/2.2	1.6	2.2	90L	ø140	172	140	278	180	148	267	387	22.6	42.1	38.6	387	27.2	46.7	43.2		
EVMSG15 3/3.0	1.6	3.0	100 L	ø160	-	-	-	196	155	306	437	24	-	46.8	437	28.5	-	51.3		
EVMSG15 4/4.0	1.6	4.0	112 S	ø160	-	-	-	196	155	306	477	25.2	-	51.7	477	29.7	-	56.2		
EVMSG15 5/5.5	1.6	5.5	132 S	ø300	-	-	-	225	160	328	614	34.9	-	73.5	614	39.5	-	78.1		
EVMSG15 6/5.5	1.6	5.5	132 S	ø300	-	-	-	225	160	328	654	36.1	-	74.7	654	40.7	-	79.3		
EVMSG15 7/7.5	1.6	7.5	132 S	ø300	-	-	-	225	160	350	694	38.3	-	78.7	694	42.9	-	83.3		
EVMSG15 8/7.5	1.6	7.5	132 S	ø300	-	-	-	225	160	350	734	39.6	-	80	734	44.2	-	84.6		
EVMSG15 9/11	1.6	11	160 M	ø350	-	-	-	248	194	476	804	40.9	-	103.4	804	45.5	-	108		
EVMSG15 10/11	1.6	11	160 M	ø350	-	-	-	248	194	476	844	42.2	-	104.7	844	46.8	-	109.3		
EVMSG15 11/11	1.6	11	160 M	ø350	-	-	-	248	194	476	884	50.2	-	112.7	884	54.7	-	117.2		
EVMSG15 12/11	2.5	11	160 M	ø350	-	-	-	248	194	476	-	-	-	-	924	56	-	118.5		
EVMSG15 13/11	2.5	11	160 M	ø350	-	-	-	248	194	476	-	-	-	-	964	57.3	-	119.8		
EVMSG15 15/15	2.5	15	160 M	ø350	-	-	-	317	238	498	-	-	-	-	1044	59.9	-	148.8		
EVMSG15 17/15	2.5	15	160 M	ø350	-	-	-	317	238	498	-	-	-	-	1124	62.8	-	151.7		

1.6 MPa=16 bar ; 2.5 MPa=25 bar
- not available model

SECTIONAL VIEW
EVMSG15

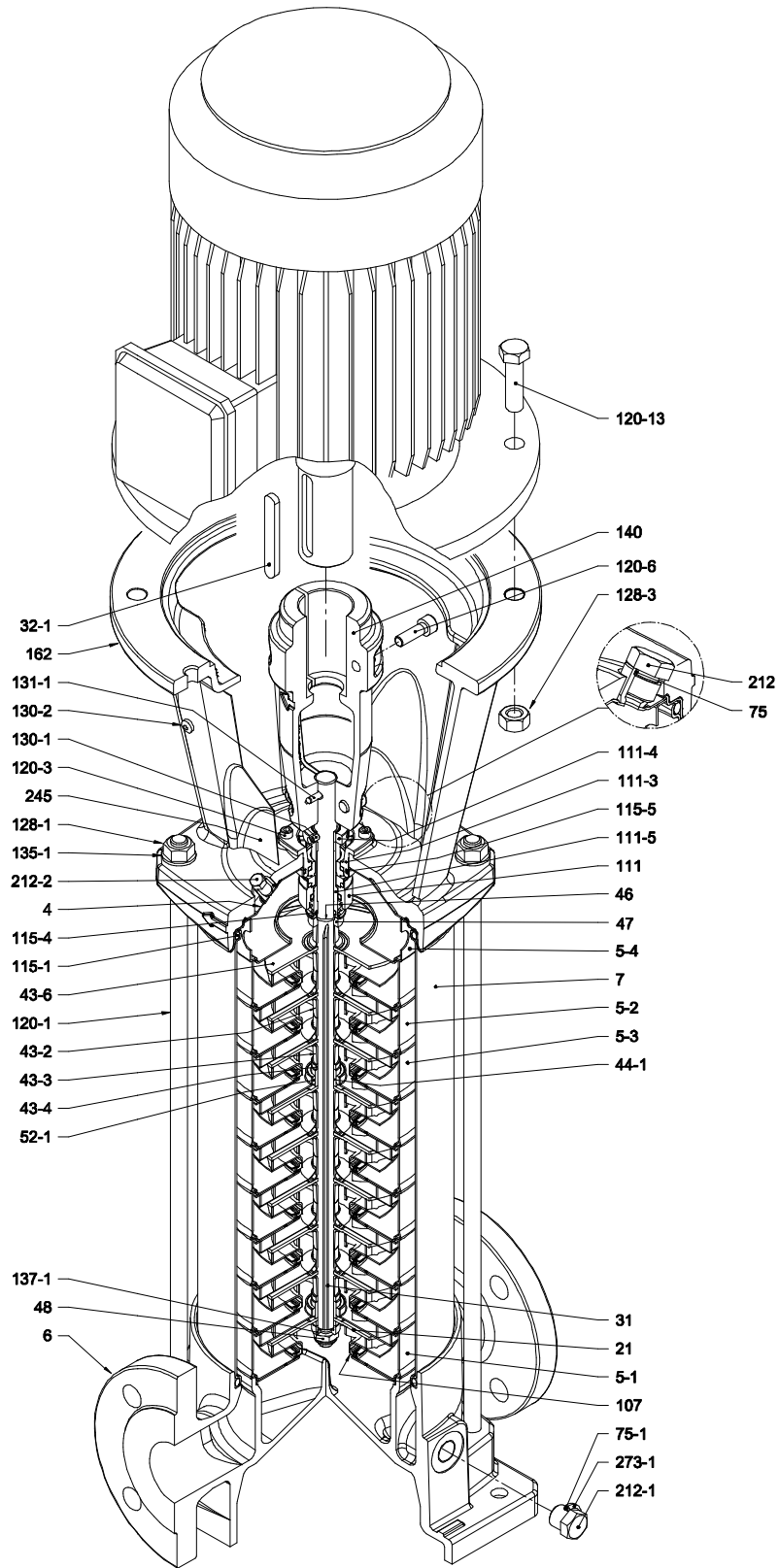

with Round flange (F)

PIPE CONNECTION EVMSG15

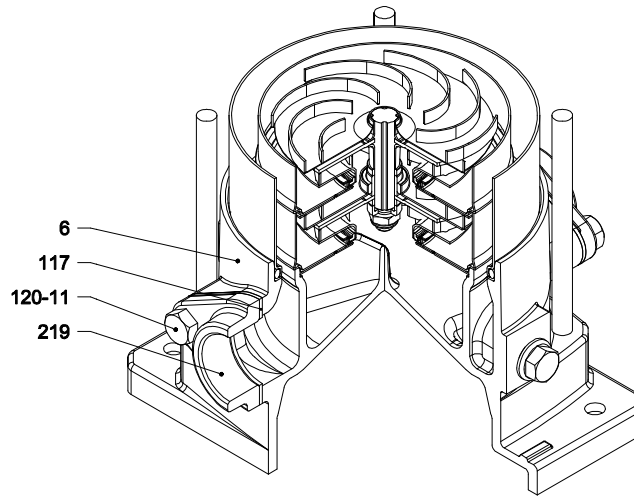

with Oval flange (N)

EVMSG15

SECTIONAL TABLE
EVMSG15

N°	PART NAME	MATERIAL EVMSG	DIMENSIONS	STANDARD	
4	Casing cover	EN 1.4301 (AISI 304)			
5-1	Suction casing	EN 1.4301 (AISI 304)			
5-2	Intermediate Casing	EN 1.4301 (AISI 304)			
5-3	Intermediate casing bearing	EN 1.4301 (AISI 304)			
5-4	Discharge casing	EN 1.4301 (AISI 304)			
6	Bottom casing	Cast Iron EN GJL-250-EN1561			
7	Outer casing	EN 1.4301 (AISI 304)			
21	Impeller	EN 1.4301 (AISI 304)			
31	Shaft	EN 1.4301 (AISI 304) - EN 1.4462 (AISI 329A)			
32-1	Adjuster Key	EN 1.4301 (AISI 304)			
43-2	Shaft sleeve (intermediate)	EN 1.4301 (AISI 304)			
43-3	Shaft sleeve (bearing)	EN 1.4301 (AISI 304)			
43-4	Shaft sleeve (adjustment)	EN 1.4301 (AISI 304)			
43-6	Washer	EN 1.4404 (AISI 316L)	D. 26x2.5		
44-1	Shaft sleeve bearing	Tungsten carbide			
46	Ring (mechanical seal)	EN 1.4404 (AISI 316L)			
47	Ring Holder	EN 1.4301 (AISI 304)			
48	Impeller nut	A2-70 UNI 7323 with inox insert	M10		
52-1	Bearing	Tungsten carbide			
75	O-Ring (plug)	EPDM	D. 12.37x2.62	OR 3050	
75-1	O-Ring (plug)	EPDM			
107	Liner ring	EN 1.4301 (AISI 304) + PPS			
111	Mechanical Seal	SiC/Carbon/EPDM			
111-3	Mechanical seal seat	EN 1.4301 (AISI 304)			
111-4	Seal holder	EN 1.4301 (AISI 304)			
111-5	Mechanical seal cartridge	EN 1.4301 (AISI 304)			
115-1	O-Ring (outer casing)	EPDM	D. 164,46x5,34	OR 6645	
115-4	O-Ring (cartridge sleeve)	EPDM	D. 15.88x2.62	OR 121	
115-5	O-Ring (seal cover)	EPDM	D. 37.77x2.62	OR 3150	
117	Flange gasket	EPDM			
120-1	Tie-rod	Galvanized steel 6.8 strength class ISO 898/1	M12		
120-3	Screw	A2-70 UNI 7323	M5x12	ISO 4762	
120-6	Screw for coupling	Galvanized steel 6.8 strength class ISO 898/1	up to 4.0 kW	M6x25	ISO 4762
			from 5.5 kW to 7.5 kW	M8x20	ISO 4762
			above 11 kW	M10x30	ISO 4762
120-11	Screw for counterflange	A2-70 UNI 7323			
120-13	Screw for motor	Galvanized steel 8.8 strength class ISO 898/1	MEC 80	M6x20	ISO 4017
			MEC 90-100-112	M8x20	ISO 4017
			MEC 132	M12x40	UNI 5739
			MEC 160	M16x50	ISO 4017
128-1	Nut for tie rod	Galvanized steel	M12	UNI 5588	
128-3	Nut (motor)	Galvanized steel	MEC 132	M12	UNI 5588
			MEC 160	M16	ISO 4032
130-1	Set screw	A2-70 UNI 7323	M5x8	UNI 5923	
130-2	Screw for coupling guard	A2-70 UNI 7323	M5x6	UNI 7687	
131-1	Pin for shaft	Carbon Steel	D. 5x35	UNI 4838	
135-1	Washer	Galvanized steel	D. 13x24x2,5	UNI 6592	
137-1	Impeller spacer	EN 1.4301 (AISI 304)			
140	Coupling	up to 4.0 kW	Die cast Aluminium EN AB-AIS11Cu2 (Fe)		
		above 5.5 kW	Cast Iron		
162	Motor bracket	Cast iron EN-GJL-200-EN 1561			
212	Plug	EN 1.4301 (AISI 304)	G 3/8		
212-1	Plug	EN 1.4301 (AISI 304)	G 3/8		
212-2	Venting plug	EN 1.4404 (AISI 316L)			
219	Counter flange	Galvanized steel			
245	Coupling guard	EN 1.4301 (AISI 304)			
273-1	Plug Washer	EN 1.4301 (AISI 304)			

QUANTITY FOR MODEL EVMSG15

Pump Type	N°																													
	4	5-1	5-2	5-3	5-4	6	7	21	31***	32-1	43-2	43-3	43-4	43-6	44-1	46	47	48	52-1	75	75-1	107	111	111-3	111-4	111-5	115-1	115-4	115-5	
EVMSG15 1/1.1	1	1	/	1	1	1	1	1	1	1	/	1	1	1	1	2	1	1	1	1	4	1	1	1	1	1	1	2	1	1
EVMSG15 2/2.2	1	1	/	1	1	1	1	2	1	1	/	1	1	/	1	2	1	1	1	1	4	2	1	1	1	1	1	2	1	1
EVMSG15 3/3.0	1	1	1	1	1	1	1	3	1	1	3	1	1	/	1	2	1	1	1	1	4	3	1	1	1	1	1	2	1	1
EVMSG15 4/4.0	1	1	2	1	1	1	1	4	1	1	5	1	1	/	1	2	1	1	1	1	4	4	1	1	1	1	1	2	1	1
EVMSG15 5/5.5	1	1	3	1	1	1	1	5	1	1	7	1	1	/	1	2	1	1	1	1	4	5	1	1	1	1	1	2	1	1
EVMSG15 6/5.5	1	1	4	1	1	1	1	6	1	1	9	1	1	/	1	2	1	1	1	1	4	6	1	1	1	1	1	2	1	1
EVMSG15 7/7.5	1	1	4	2	1	1	1	7	1	1	9	2	2	/	2	2	1	1	2	1	4	7	1	1	1	1	1	2	1	1
EVMSG15 8/7.5	1	1	5	2	1	1	1	8	1	1	11	2	2	/	2	2	1	1	2	1	4	8	1	1	1	1	1	2	1	1
EVMSG15 9/11	1	1	6	2	1	1	1	9	1	1	13	2	2	/	2	2	1	1	2	1	4	9	1	1	1	1	1	2	1	1
EVMSG15 10/11	1	1	7	2	1	1	1	10	1	1	15	1	2	/	2	2	1	1	2	1	4	10	1	1	1	1	1	2	1	1
EVMSG15 11/11	1	1	8	2	1	1	1	11	1	1	17	1	2	/	2	2	1	1	2	1	4	11	1	1	1	1	1	2	1	1
EVMSG15 12/11	1	1	9	2	1	1	1	12	1	1	19	1	2	/	2	2	1	1	2	1	4	12	1	1	1	1	1	2	1	1
EVMSG15 13/11	1	1	10	2	1	1	1	13	1	1	21	1	2	/	2	2	1	1	2	1	4	13	1	1	1	1	1	2	1	1
EVMSG15 15/15	1	1	12	2	1	1	1	15	1	1	25	1	2	/	2	2	1	1	2	1	4	15	1	1	1	1	1	2	1	1
EVMSG15 17/15	1	1	13	3	1	1	1	17	1	1	27	2	2	/	3	2	1	1	3	1	4	17	1	1	1	1	1	2	1	1

Pump Type	N°																						
	117*	120-1	120-3	120-6	120-11*	120-13	128-1	128-3	128-6	130-1	130-2	131-1	135-1	135-6	137-1	140	162	212	212-1	212-2	219*	245	273-1
EVMSG15 1/1.1	2	4	4	4	4	4	4	/	4	3	4	1	4	4	1	2	1	1	4	1	2	2	4
EVMSG15 2/2.2	2	4	4	4	4	4	4	/	4	3	4	1	4	4	1	2	1	1	4	1	2	2	4
EVMSG15 3/3.0	2	4	4	4	4	4	4	/	4	3	4	1	4	4	1	2	1	1	4	1	2	2	4
EVMSG15 4/4.0	2	4	4	4	4	4	4	/	4	3	4	1	4	4	1	2	1	1	4	1	2	2	4
EVMSG15 5/5.5	2	4	4	4	4	4	4	/	3	4	1	4	/	1	2	1	1	4	1	2	2	4	
EVMSG15 6/5.5	2	4	4	4	4	4	4	/	3	4	1	4	/	1	2	1	1	4	1	2	2	4	
EVMSG15 7/7.5	2	4	4	4	4	4	4	/	3	4	1	4	/	1	2	1	1	4	1	2	2	4	
EVMSG15 8/7.5	2	4	4	4	4	4	4	/	3	4	1	4	/	1	2	1	1	4	1	2	2	4	
EVMSG15 9/11	2	4	4	4	4	4	4	/	3	4	1	4	/	1	2	1	1	4	1	2	2	4	
EVMSG15 10/11	2	4	4	4	4	4	4	/	3	4	1	4	/	1	2	1	1	4	1	2	2	4	
EVMSG15 11/11	2	4	4	4	4	4	4	/	3	4	1	4	/	1	2	1	1	4	1	2	2	4	
EVMSG15 12/11	/	4	4	4	/	4	4	/	3	4	1	4	/	1	2	1	1	4	1	/	2	4	
EVMSG15 13/11	/	4	4	4	/	4	4	/	3	4	1	4	/	1	2	1	1	4	1	/	2	4	
EVMSG15 15/15	/	4	4	4	/	4	4	/	3	4	1	4	/	1	2	1	1	4	1	/	2	4	
EVMSG15 17/15	/	4	4	4	/	4	4	/	3	4	1	4	/	1	2	1	1	4	1	/	2	4	

* only for Oval flange (N)

*** shaft in EN 1.4462 (AISI 329A)

128-6 / 135-6 : with Aluminium coupling (see drawing pag.211)

PERFORMANCE CURVE
EVMS(L)20

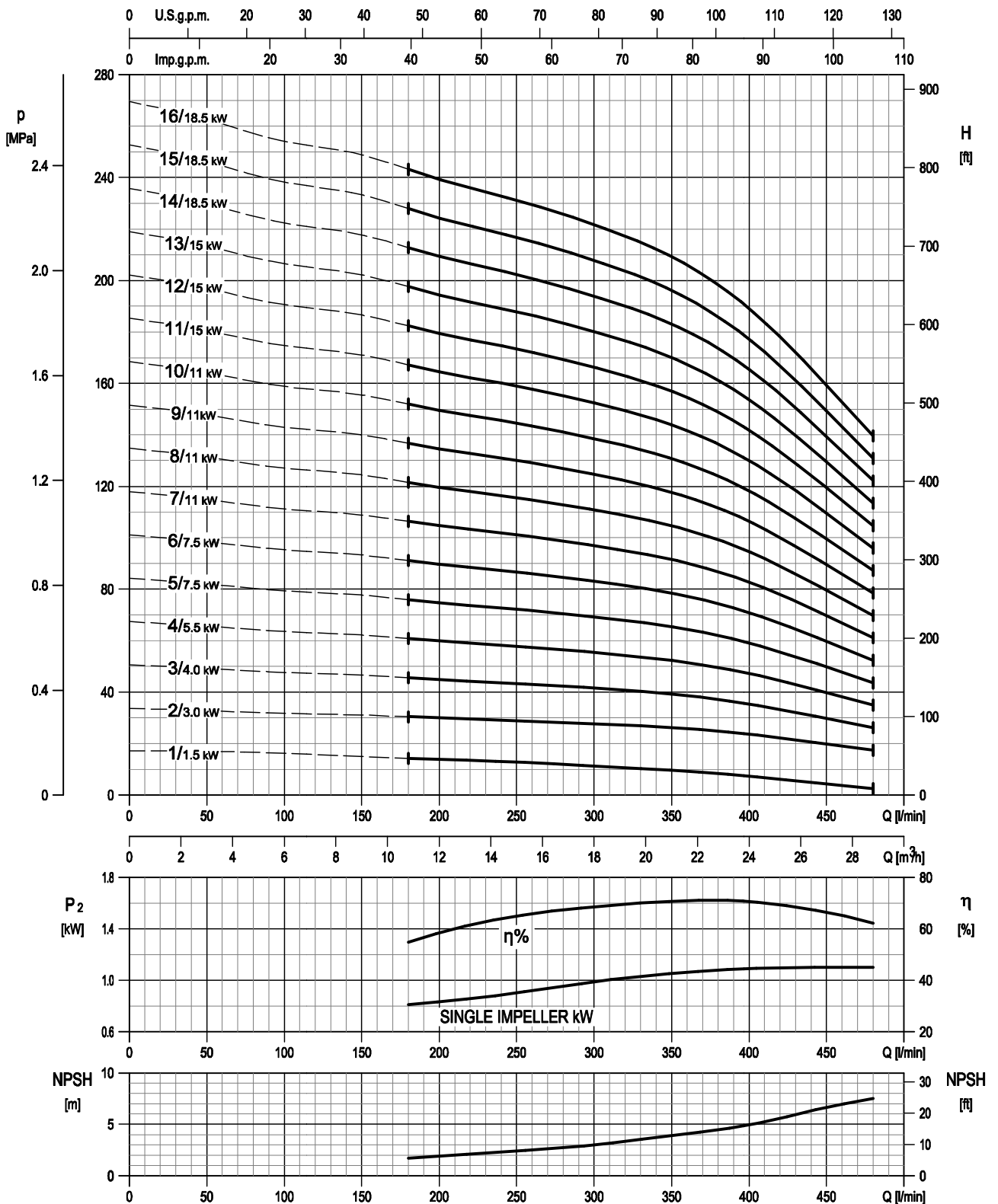

Rotation speed $\approx 2900 \text{ min}^{-1}$
Test standard: ISO 9906:2012 - Grade 3B

TECHNICAL DATA EVMS(L)20

Dimensional sketch

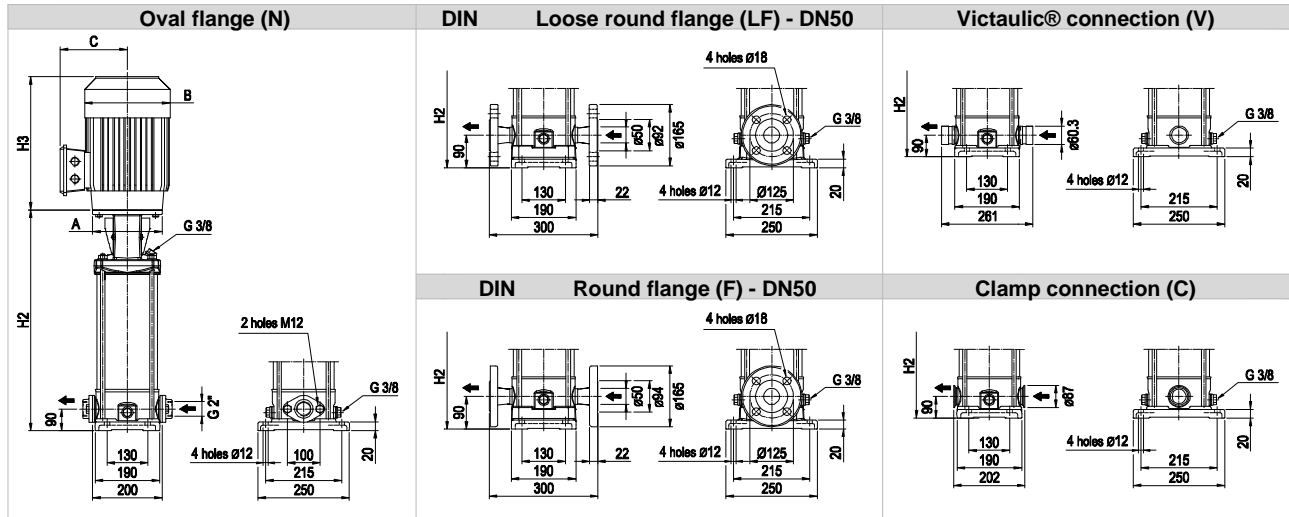

Dimensions [mm] and Weights [Kg]

Pump Type	Pmax [MPa]	kW	Motor									Oval flange (N)			Loose round flange (LF) Round flange (F)			Victaulic® connection (V) Clamp connection (C)						
			Size	A			1 ~			3 ~			H2	Weight Pump	Weight Pump + Motor		H2	Weight Pump	Weight Pump + Motor		H2	Weight Pump	Weight Pump + Motor	
				B	C	H3	B	C	H3	B	C	H3			1 ~	3 ~			1 ~	3 ~			1 ~	3 ~
EVMS(L)20 1/1.5	1.6	1.5	90 S	ø140	172	140	278	180	148	267	387	18.2	36.0	30.9	387	20	37.8	32.7	387	17.1	34.9	29.8		
EVMS(L)20 2/3.0	1.6	3.0	100 L	ø160	-	-	-	196	155	306	397	18.3	-	41.1	397	19.1	-	41.9	397	17.2	-	40		
EVMS(L)20 3/4.0	1.6	4.0	112 M	ø160	-	-	-	196	155	306	437	19.7	-	46.2	437	20.5	-	47	437	18.6	-	45.1		
EVMS(L)20 4/5.5	1.6	5.5	132 S	ø300	-	-	-	225	160	328	574	25.6	-	64.2	574	26.4	-	65	574	24.5	-	63.1		
EVMS(L)20 5/7.5	1.6	7.5	132 S	ø300	-	-	-	225	160	350	614	26.9	-	67.3	614	27.7	-	68.1	614	25.8	-	66.2		
EVMS(L)20 6/7.5	1.6	7.5	132 S	ø300	-	-	-	225	160	350	654	28.1	-	68.5	654	28.9	-	69.3	654	27	-	67.4		
EVMS(L)20 7/11	1.6	11	160 M	ø350	-	-	-	248	194	476	724	30.4	-	92.9	724	31.2	-	93.7	724	29.3	-	91.8		
EVMS(L)20 8/11	1.6	11	160 M	ø350	-	-	-	248	194	476	764	42.2	-	104.7	764	43	-	105.5	764	41.1	-	103.6		
EVMS(L)20 9/11	1.6	11	160 M	ø350	-	-	-	248	194	476	804	43.5	-	106	804	44.3	-	106.8	804	42.4	-	104.9		
EVMS(L)20 10/11	2.5	11	160 M	ø350	-	-	-	248	194	476	-	-	-	844	45.7	-	108.2	844	43.8	-	106.3			
EVMS(L)20 11/15	2.5	15	160 M	ø350	-	-	-	317	238	498	-	-	-	884	47	-	135.9	884	45.1	-	134			
EVMS(L)20 12/15	2.5	15	160 M	ø350	-	-	-	317	238	498	-	-	-	924	48.3	-	137.2	924	46.4	-	135.3			
EVMS(L)20 13/15	2.5	15	160 M	ø350	-	-	-	317	238	498	-	-	-	964	49.6	-	138.5	964	47.7	-	136.6			
EVMS(L)20 14/18.5	2.5	18.5	160 L	ø350	-	-	-	317	238	542	-	-	-	1004	51	-	155	1004	49.1	-	153.1			
EVMS(L)20 15/18.5	2.5	18.5	160 L	ø350	-	-	-	317	238	542	-	-	-	1044	52.3	-	156.3	1044	50.4	-	154.4			
EVMS(L)20 16/18.5	2.5	18.5	160 L	ø350	-	-	-	317	238	542	-	-	-	1084	53.6	-	157.6	1084	51.7	-	155.7			

1.6 MPa=16 bar ; 2.5 MPa=25 bar
- not available model

SECTIONAL VIEW
EVMS(L)20

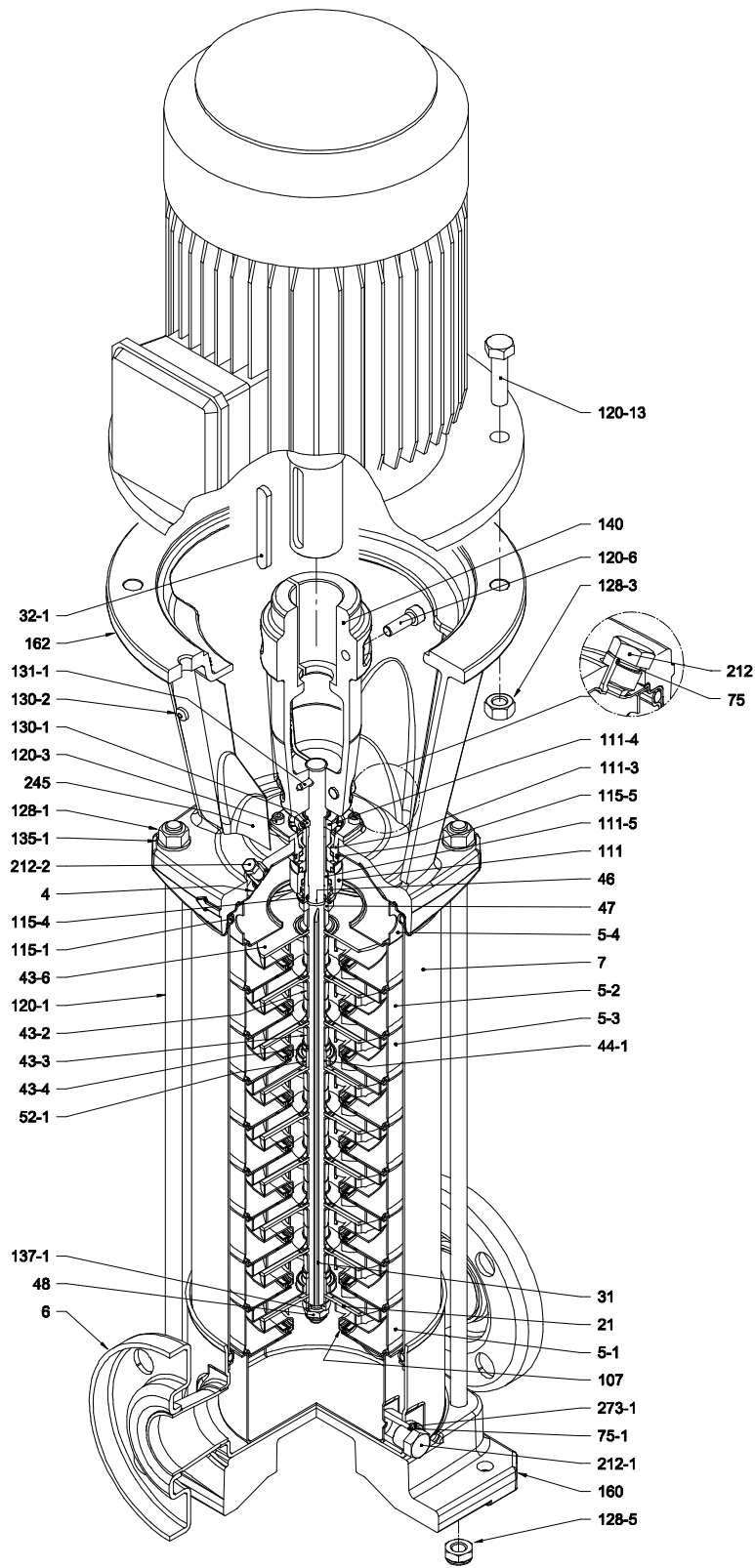

with Round flange (F)

PIPE CONNECTION EVMS(L)20

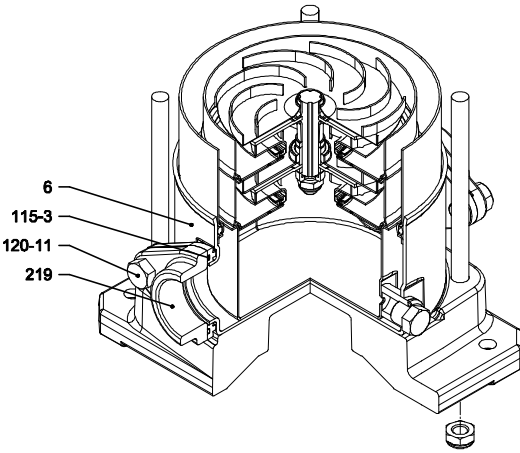

with Oval flange (N)

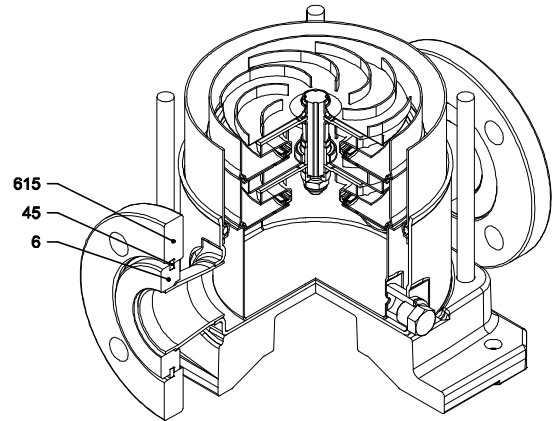

with Loose round flange (LF)

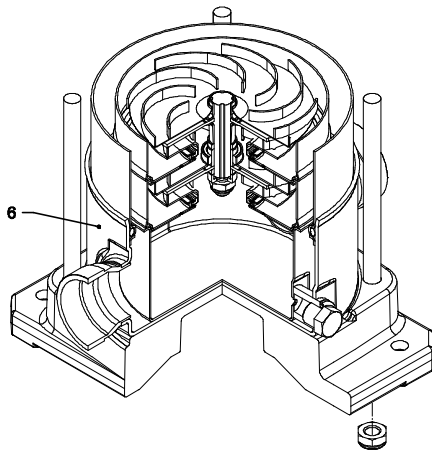

with Victaulic® connection (V)

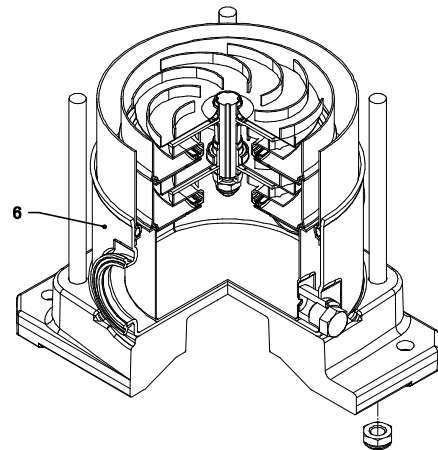

with Clamp connection (C)

SECTIONAL TABLE
EVMS(L)20

N°	PART NAME	MATERIAL		DIMENSIONS	STANDARD
		EVMS	EVMSL		
4	Casing cover	EN 1.4301 (AISI 304)	EN 1.4401 (AISI 316)		
5-1	Suction casing	EN 1.4301 (AISI 304)	EN 1.4401 (AISI 316)		
5-2	Intermediate Casing	EN 1.4301 (AISI 304)	EN 1.4401 (AISI 316)		
5-3	Intermediate casing bearing	EN 1.4301 (AISI 304)	EN 1.4401 (AISI 316)		
5-4	Discharge casing	EN 1.4301 (AISI 304)	EN 1.4401 (AISI 316)		
6	Bottom casing	EN 1.4301 (AISI 304)	EN 1.4401 (AISI 316)		
7	Outer casing	EN 1.4301 (AISI 304)	EN 1.4404 (AISI 316L)		
21	Impeller	EN 1.4301 (AISI 304)	EN 1.4401 (AISI 316)		
31	Shaft	EN 1.4301 (AISI 304) - EN 1.4462 (AISI 329A)	EN 1.4404 (AISI 316L) - EN 1.4462 (AISI 329A)		
32-1	Adjuster Key	EN 1.4301 (AISI 304)			
43-2	Shaft sleeve (intermediate)	EN 1.4301 (AISI 304)	EN 1.4404 (AISI 316L)		
43-3	Shaft sleeve (bearing)	EN 1.4301 (AISI 304)	EN 1.4401 (AISI 316)		
43-4	Shaft sleeve (adjustment)	EN 1.4301 (AISI 304)	EN 1.4401 (AISI 316)		
43-6	Washer	EN 1.4404 (AISI 316L)		D. 26x2,5	
44-1	Shaft sleeve bearing	Tungsten carbide			
45	Flange holder	EN 1.4301 (AISI 304)			
46	Ring (mechanical seal)	EN 1.4404 (AISI 316L)			
47	Ring Holder	EN 1.4301 (AISI 304)	EN 1.4401 (AISI 316)		
48	Impeller nut	A2-70 UNI 7323 with inox insert	A4-70 UNI 7323 with inox insert	M10	
52-1	Bearing	Tungsten carbide			
75	O-Ring (plug)	EPDM		D. 12.37x2.62	OR 3050
75-1	O-Ring (plug)	EPDM			
107	Liner ring	EN 1.4301 (AISI 304) + PPS	EN 1.4401 (AISI 316) + PPS		
111	Mechanical Seal	SiC/Carbon/EPDM			
111-3	Mechanical seal seat	EN 1.4301 (AISI 304)	EN 1.4401 (AISI 316)		
111-4	Seal holder	EN 1.4301 (AISI 304)			
111-5	Mechanical seal cartridge	EN 1.4301 (AISI 304)	EN 1.4401 (AISI 316)		
115-1	O-Ring (outer casing)	EPDM		D. 164,46x5,34	OR 6645
115-3	O-Ring	EPDM			
115-4	O-Ring (cartridge sleeve)	EPDM		D. 15,88x2,62	OR 121
115-5	O-Ring (seal cover)	EPDM		D. 37,77x2,62	OR 3150
120-1	Tie-rod	Galvanized steel 6.8 strength class ISO 898/1		M12	
120-3	Screw	A2-70 UNI 7323		M5x12	ISO 4762
120-6	Screw for coupling	up to 4.0 kW from 5.5 kW to 7.5 kW above 11 kW	Galvanized steel	M6x25	ISO 4762
				M8x20	ISO 4762
				M10x30	ISO 4762
120-11	Screw for counterflange	A2-70 UNI 7323			
120-13	Screw for motor	MEC 90-100-112 MEC 132 MEC 160	Galvanized steel 8.8 strength class ISO 898/1	M8x20	ISO 4017
				M12x40	UNI 5739
				M16x50	ISO 4017
128-1	Nut for tie rod	Galvanized steel		M12	UNI 5588
128-3	Nut (motor)	MEC 132 MEC 160	Galvanized steel	M12	UNI 5588
				M16	ISO 4032
128-5	Nut for tie rod	Galvanized steel		M12	UNI 7474
130-1	Set screw	A2-70 UNI 7323		M5x8	UNI 5923
130-2	Screw for coupling guard	A2-70 UNI 7323		M5x6	UNI 7687
131-1	Pin for shaft	Carbon Steel		D. 5x35	UNI 4838
135-1	Washer	Galvanized steel		D. 13x24x2,5	UNI 6592
137-1	Impeller spacer	EN 1.4301 (AISI 304)	EN 1.4401 (AISI 316)		
140	Coupling	up to 4.0 kW above 5.5 kW	Die cast Aluminium EN AB-AISI11Cu2 (Fe)		
			Cast Iron		
160	Base	Die cast Aluminium EN AB-AISI11Cu2 (Fe)			
162	Motor bracket	Cast iron EN-GJL-200-EN 1561			
212	Plug	EN 1.4301 (AISI 304)	EN 1.4401 (AISI 316)	G 3/8	
212-1	Plug	EN 1.4301 (AISI 304)	EN 1.4401 (AISI 316)	G 3/8	
212-2	Venting plug	EN 1.4404 (AISI 316L)			
219	Counter flange	EN 1.4301 (AISI 304)	EN 1.4401 (AISI 316)		
245	Coupling guard	EN 1.4301 (AISI 304)			
273-1	Plug Washer	EN 1.4301 (AISI 304)	EN 1.4401 (AISI 316)		
615	Flange	Carbon steel			

QUANTITY FOR MODEL EVMS(L)20

Pump Type	N°																															
	4	5-1	5-2	5-3	5-4	6	7	21	31***	32-1	43-2	43-3	43-4	43-6	44-1	45**	46	47	48	52-1	75	75-1	107	111	111-3	111-4	111-5	115-1	115-3*	115-4	115-5	
EVMS(L)20 1/1.5	1	1	/	1	1	1	1	1	1	1	/	1	1	1	1	4	2	1	1	1	1	2	1	1	1	1	1	1	2	2	1	1
EVMS(L)20 2/3.0	1	1	/	1	1	1	1	2	1	1	/	1	1	/	1	4	2	1	1	1	1	2	2	1	1	1	1	1	2	2	1	1
EVMS(L)20 3/4.0	1	1	1	1	1	1	1	3	1	1	3	1	1	/	1	4	2	1	1	1	1	2	3	1	1	1	1	1	2	2	1	1
EVMS(L)20 4/5.5	1	1	2	1	1	1	1	4	1	1	5	1	1	/	1	4	2	1	1	1	1	2	4	1	1	1	1	1	2	2	1	1
EVMS(L)20 5/7.5	1	1	3	1	1	1	1	5	1	1	7	1	1	/	1	4	2	1	1	1	1	2	5	1	1	1	1	1	2	2	1	1
EVMS(L)20 6/7.5	1	1	4	1	1	1	1	6	1	1	9	1	1	/	1	4	2	1	1	1	1	2	6	1	1	1	1	1	2	2	1	1
EVMS(L)20 7/11	1	1	4	2	1	1	1	7	1	1	9	2	2	/	2	4	2	1	1	2	1	2	7	1	1	1	1	1	2	2	1	1
EVMS(L)20 8/11	1	1	5	2	1	1	1	8	1	1	11	2	2	/	2	4	2	1	1	2	1	2	8	1	1	1	1	1	2	2	1	1
EVMS(L)20 9/11	1	1	6	2	1	1	1	9	1	1	13	2	2	/	2	4	2	1	1	2	1	2	9	1	1	1	1	1	2	2	1	1
EVMS(L)20 10/11	1	1	7	2	1	1	1	10	1	1	15	2	2	/	2	4	2	1	1	2	1	2	10	1	1	1	1	1	2	/	1	1
EVMS(L)20 11/15	1	1	8	2	1	1	1	11	1	1	17	2	2	/	2	4	2	1	1	2	1	2	11	1	1	1	1	1	2	/	1	1
EVMS(L)20 12/15	1	1	9	2	1	1	1	12	1	1	19	2	2	/	2	4	2	1	1	2	1	2	12	1	1	1	1	1	2	/	1	1
EVMS(L)20 13/15	1	1	10	2	1	1	1	13	1	1	21	2	2	/	2	4	2	1	1	2	1	2	13	1	1	1	1	1	2	/	1	1
EVMS(L)20 14/18.5	1	1	11	2	1	1	1	14	1	1	23	2	2	/	2	4	2	1	1	2	1	2	14	1	1	1	1	1	2	/	1	1
EVMS(L)20 15/18.5	1	1	12	2	1	1	1	15	1	1	25	2	2	/	2	4	2	1	1	2	1	2	15	1	1	1	1	1	2	/	1	1
EVMS(L)20 16/18.5	1	1	13	2	1	1	1	16	1	1	27	2	2	/	2	4	2	1	1	2	1	2	16	1	1	1	1	1	2	/	1	1

Pump Type	N°																								
	120-1	120-3	120-6	120-11*	120-13	128-1	128-3	128-5	128-6	130-1	130-2	131-1	135-1	135-6	137-1	140	160	162	212	212-1	212-2	219*	245	273-1	615**
EVMS(L)20 1/1.5	4	4	4	4	4	4	/	4	4	3	4	1	4	4	1	2	1	1	1	2	1	2	2	2	2
EVMS(L)20 2/3.0	4	4	4	4	4	4	/	4	4	3	4	1	4	4	1	2	1	1	1	2	1	2	2	2	
EVMS(L)20 3/4.0	4	4	4	4	4	4	/	4	4	3	4	1	4	4	1	2	1	1	1	2	1	2	2	2	
EVMS(L)20 4/5.5	4	4	4	4	4	4	4	4	4	3	4	1	4	/	1	2	1	1	1	2	1	2	2	2	
EVMS(L)20 5/7.5	4	4	4	4	4	4	4	4	4	3	4	1	4	/	1	2	1	1	1	2	1	2	2	2	
EVMS(L)20 6/7.5	4	4	4	4	4	4	4	4	4	3	4	1	4	/	1	2	1	1	1	2	1	2	2	2	
EVMS(L)20 7/11	4	4	4	4	4	4	4	4	4	3	4	1	4	/	1	2	1	1	1	2	1	2	2	2	
EVMS(L)20 8/11	4	4	4	4	4	4	4	4	4	3	4	1	4	/	1	2	1	1	1	2	1	2	2	2	
EVMS(L)20 9/11	4	4	4	4	4	4	4	4	4	3	4	1	4	/	1	2	1	1	1	2	1	2	2	2	
EVMS(L)20 10/11	4	4	4	/	4	4	4	4	4	3	4	1	4	/	1	2	1	1	1	2	1	2	2	2	
EVMS(L)20 11/15	4	4	4	/	4	4	4	4	4	3	4	1	4	/	1	2	1	1	1	2	1	/	2	2	
EVMS(L)20 12/15	4	4	4	/	4	4	4	4	4	3	4	1	4	/	1	2	1	1	1	2	1	/	2	2	
EVMS(L)20 13/15	4	4	4	/	4	4	4	4	4	3	4	1	4	/	1	2	1	1	1	2	1	/	2	2	
EVMS(L)20 14/18.5	4	4	4	/	4	4	4	4	4	3	4	1	4	/	1	2	1	1	1	2	1	/	2	2	
EVMS(L)20 15/18.5	4	4	4	/	4	4	4	4	4	3	4	1	4	/	1	2	1	1	1	2	1	/	2	2	
EVMS(L)20 16/18.5	4	4	4	/	4	4	4	4	4	3	4	1	4	/	1	2	1	1	1	2	1	/	2	2	

* only for Oval flange (N)

** only for Loose round flange (LF)

*** shaft in EN 1.4462 (AISI 329A)

128-6 / 135-6 : with Aluminium coupling (see drawing pag.211)

PERFORMANCE CURVE
EVMSG20

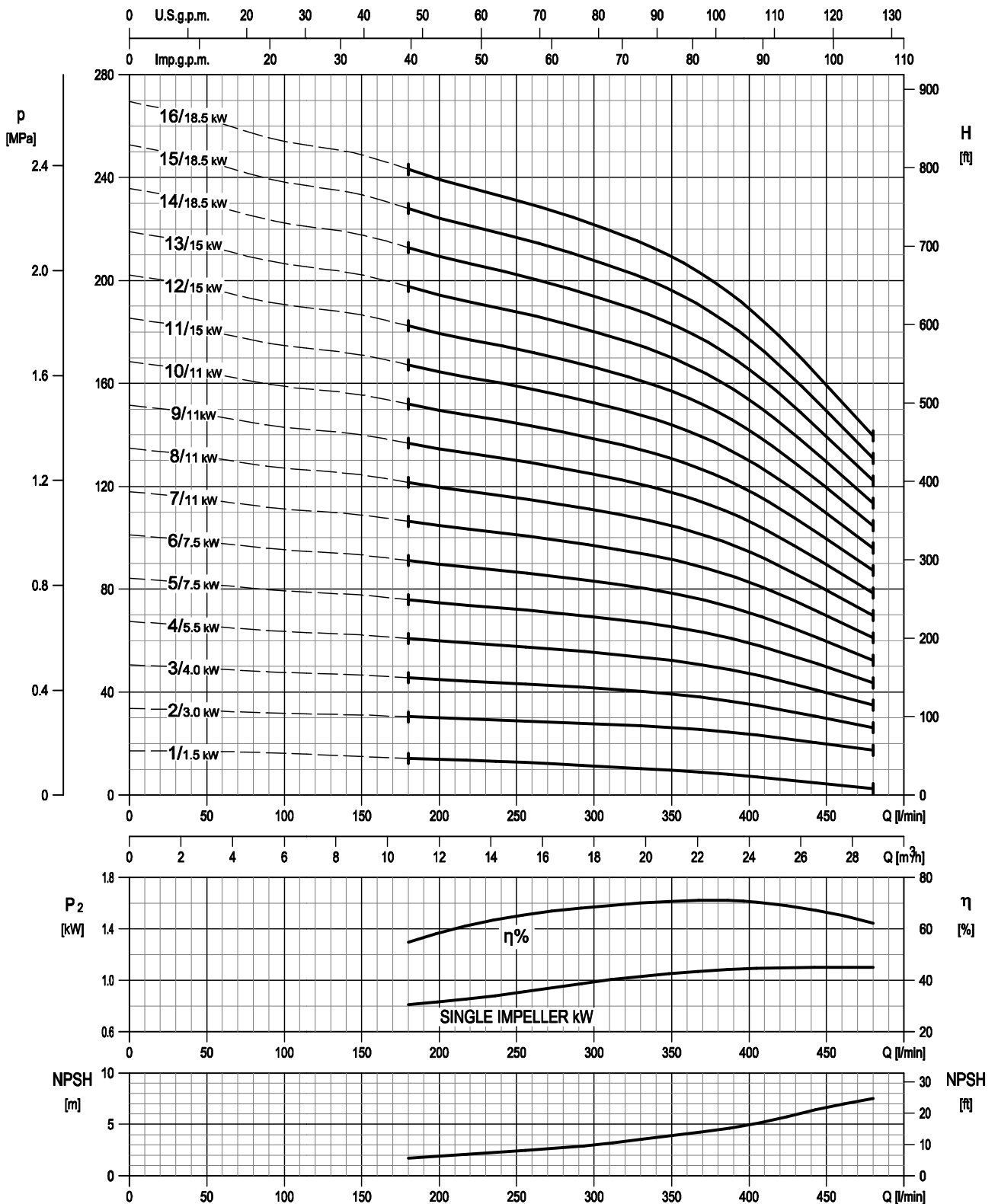

Rotation speed $\approx 2900 \text{ min}^{-1}$
Test standard: ISO 9906:2012 - Grade 3B

TECHNICAL DATA EVMSG20

Dimensional sketch

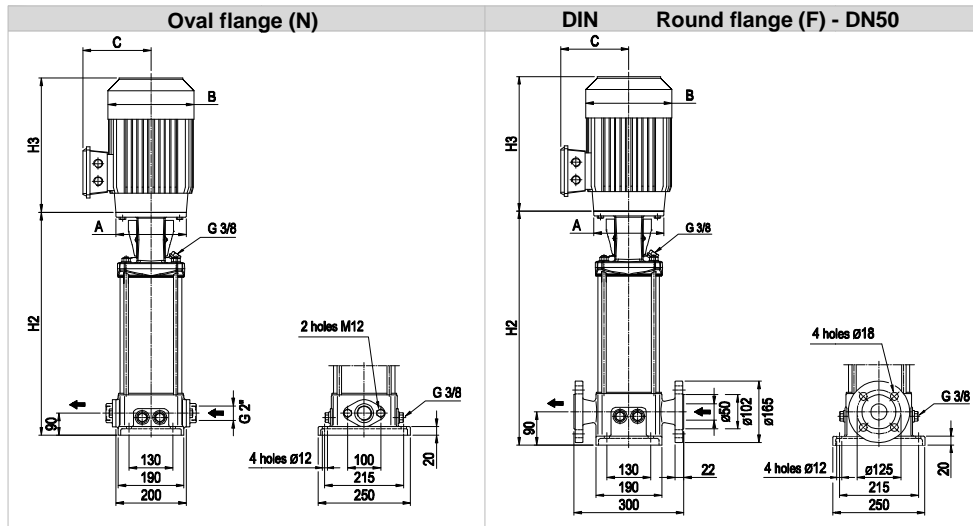

Dimensions [mm] and Weights [Kg]

Pump Type	P _{max} [MPa]	kW	Size	Motor									Oval flange (N)			Round flange (F)				
				A			1 ~			3 ~			H2	Weight Pump	Weight Pump + Motor		H2	Weight Pump	Weight Pump + Motor	
				B	C	H3	B	C	H3	B	C	H3			1 ~	3 ~			1 ~	3 ~
EVMSG20 1/1.5	1.6	1.5	90 S	ø140	172	140	278	180	148	267	387	22.6	40.4	35.3	387	27.2	45	39.9		
EVMSG20 2/3.0	1.6	3.0	100 L	ø160	-	-	-	196	155	306	397	22.7	-	45.5	397	27.3	-	50.1		
EVMSG20 3/4.0	1.6	4.0	112 M	ø160	-	-	-	196	155	306	437	24.1	-	50.6	437	28.7	-	55.2		
EVMSG20 4/5.5	1.6	5.5	132 S	ø300	-	-	-	225	160	328	574	30	-	68.6	574	34.6	-	73.2		
EVMSG20 5/7.5	1.6	7.5	132 S	ø300	-	-	-	225	160	350	614	31.2	-	71.6	614	35.9	-	76.3		
EVMSG20 6/7.5	1.6	7.5	132 S	ø300	-	-	-	225	160	350	654	32.5	-	72.9	654	37.1	-	77.5		
EVMSG20 7/11	1.6	11	160 M	ø350	-	-	-	248	194	476	724	34.8	-	97.3	724	39.4	-	101.9		
EVMSG20 8/11	1.6	11	160 M	ø350	-	-	-	248	194	476	764	46.6	-	109.1	764	51.2	-	113.7		
EVMSG20 9/11	1.6	11	160 M	ø350	-	-	-	248	194	476	804	47.9	-	110.4	804	52.5	-	115		
EVMSG20 10/11	2.5	11	160 M	ø350	-	-	-	248	194	476	-	-	-	-	844	53.9	-	116.4		
EVMSG20 11/15	2.5	15	160 M	ø350	-	-	-	317	238	498	-	-	-	-	884	55.2	-	144.1		
EVMSG20 12/15	2.5	15	160 M	ø350	-	-	-	317	238	498	-	-	-	-	924	56.5	-	145.4		
EVMSG20 13/15	2.5	15	160 M	ø350	-	-	-	317	238	498	-	-	-	-	964	57.9	-	146.8		
EVMSG20 14/18.5	2.5	18.5	160 L	ø350	-	-	-	317	238	542	-	-	-	-	1004	59.2	-	163.2		
EVMSG20 15/18.5	2.5	18.5	160 L	ø350	-	-	-	317	238	542	-	-	-	-	1044	60.5	-	164.5		
EVMSG20 16/18.5	2.5	18.5	160 L	ø350	-	-	-	317	238	542	-	-	-	-	1084	61.8	-	165.8		

1.6 MPa=16 bar ; 2.5 MPa=25 bar
- not available model

SECTIONAL VIEW
EVMSG20

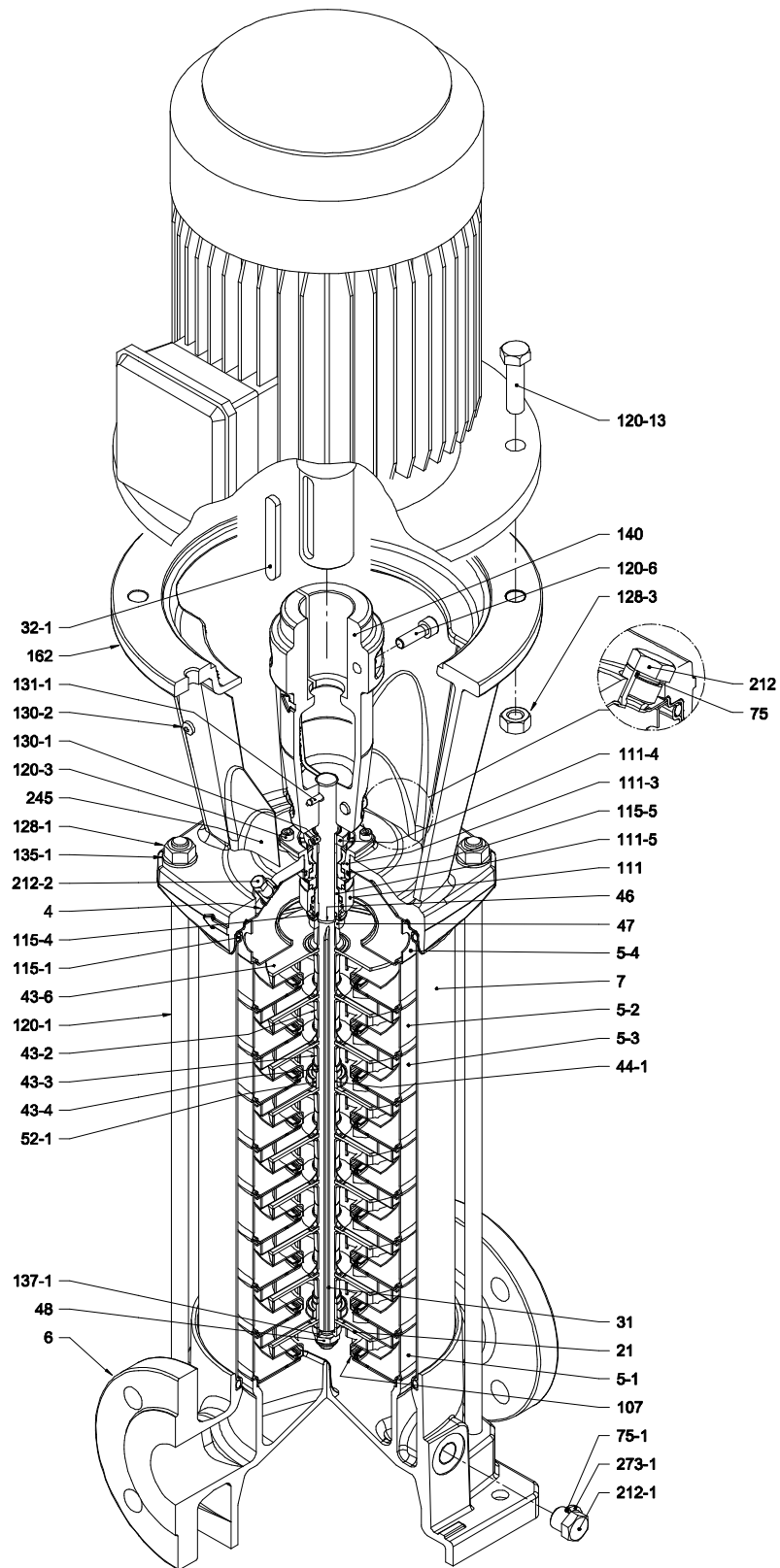

with Round flange (F)

PIPE CONNECTION EVMSG20

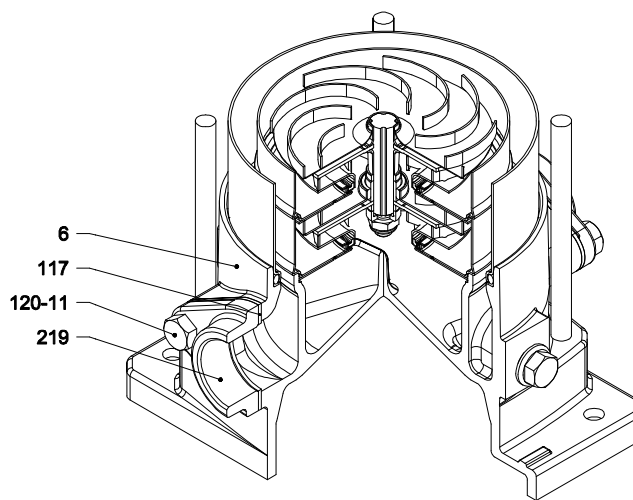

with Oval flange (N)

EVMSG20

SECTIONAL TABLE
EVMSG20

N°	PART NAME	MATERIAL EVMSG	DIMENSIONS	STANDARD	
4	Casing cover	EN 1.4301 (AISI 304)			
5-1	Suction casing	EN 1.4301 (AISI 304)			
5-2	Intermediate Casing	EN 1.4301 (AISI 304)			
5-3	Intermediate casing bearing	EN 1.4301 (AISI 304)			
5-4	Discharge casing	EN 1.4301 (AISI 304)			
6	Bottom casing	Cast Iron EN GJL-250-EN1561			
7	Outer casing	EN 1.4301 (AISI 304)			
21	Impeller	EN 1.4301 (AISI 304)			
31	Shaft	EN 1.4301 (AISI 304) - EN 1.4462 (AISI 329A)			
32-1	Adjuster Key	EN 1.4301 (AISI 304)			
43-2	Shaft sleeve (intermediate)	EN 1.4301 (AISI 304)			
43-3	Shaft sleeve (bearing)	EN 1.4301 (AISI 304)			
43-4	Shaft sleeve (adjustment)	EN 1.4301 (AISI 304)			
43-6	Washer	EN 1.4404 (AISI 316L)	D. 26x2.5		
44-1	Shaft sleeve bearing	Tungsten carbide			
46	Ring (mechanical seal)	EN 1.4404 (AISI 316L)			
47	Ring Holder	EN 1.4301 (AISI 304)			
48	Impeller nut	A2-70 UNI 7323 with inox insert	M10		
52-1	Bearing	Tungsten carbide			
75	O-Ring (plug)	EPDM	D. 12.37x2.62	OR 3050	
75-1	O-Ring (plug)	EPDM			
107	Liner ring	EN 1.4301 (AISI 304) + PPS			
111	Mechanical Seal	SiC/Carbon/EPDM			
111-3	Mechanical seal seat	EN 1.4301 (AISI 304)			
111-4	Seal holder	EN 1.4301 (AISI 304)			
111-5	Mechanical seal cartridge	EN 1.4301 (AISI 304)			
115-1	O-Ring (outer casing)	EPDM	D. 164,46x5,34	OR 6645	
115-4	O-Ring (cartridge sleeve)	EPDM	D. 15.88x2.62	OR 121	
115-5	O-Ring (seal cover)	EPDM	D. 37.77x2.62	OR 3150	
117	Flange gasket	EPDM			
120-1	Tie-rod	Galvanized steel 6.8 strength class ISO 898/1	M12		
120-3	Screw	A2-70 UNI 7323	M5x12	ISO 4762	
120-6	Screw for coupling	Galvanized steel 6.8 strength class ISO 898/1	up to 4.0 kW	M6x25	ISO 4762
			from 5.5 kW to 7.5 kW	M8x20	ISO 4762
			above 11 kW	M10x30	ISO 4762
120-11	Screw for counterflange	A2-70 UNI 7323			
120-13	Screw for motor	Galvanized steel 8.8 strength class ISO 898/1	MEC 90-100-112	M8x20	ISO 4017
			MEC 132	M12x40	UNI 5739
			MEC 160	M16x50	ISO 4017
128-1	Nut for tie rod	Galvanized steel	M12	UNI 5588	
128-3	Nut (motor)	Galvanized steel	M12	UNI 5588	
			M16	ISO 4032	
130-1	Set screw	A2-70 UNI 7323	M5x8	UNI 5923	
130-2	Screw for coupling guard	A2-70 UNI 7323	M5x6	UNI 7687	
131-1	Pin for shaft	Carbon Steel	D. 5x35	UNI 4838	
135-1	Washer	Galvanized steel	D. 13x24x2,5	UNI 6592	
137-1	Impeller spacer	EN 1.4301 (AISI 304)			
140	Coupling	Die cast Aluminium EN AB-AISI11Cu2 (Fe)			
		Cast Iron			
162	Motor bracket	Cast iron EN-GJL-200-EN 1561			
212	Plug	EN 1.4301 (AISI 304)	G 3/8		
212-1	Plug	EN 1.4301 (AISI 304)	G 3/8		
212-2	Venting plug	EN 1.4404 (AISI 316L)			
219	Counter flange	Galvanized steel			
245	Coupling guard	EN 1.4301 (AISI 304)			
273-1	Plug Washer	EN 1.4301 (AISI 304)			

QUANTITY FOR MODEL EVMSG20

Pump Type	N°																												
	4	5-1	5-2	5-3	5-4	6	7	21	31***	32-1	43-2	43-3	43-4	43-6	44-1	46	47	48	52-1	75	75-1	107	111	111-3	111-4	111-5	115-1	115-4	115-5
EVMSG20 1/1.5	1	1	/	1	1	1	1	1	1	1	/	1	1	1	1	2	1	1	1	1	4	1	1	1	1	1	2	1	1
EVMSG20 2/3.0	1	1	/	1	1	1	1	2	1	1	/	1	1	/	1	2	1	1	1	1	4	2	1	1	1	1	2	1	1
EVMSG20 3/4.0	1	1	1	1	1	1	1	3	1	1	3	1	1	/	1	2	1	1	1	1	4	3	1	1	1	1	2	1	1
EVMSG20 4/5.5	1	1	2	1	1	1	1	4	1	1	5	1	1	/	1	2	1	1	1	1	4	4	1	1	1	1	2	1	1
EVMSG20 5/7.5	1	1	3	1	1	1	1	5	1	1	7	1	1	/	1	2	1	1	1	1	4	5	1	1	1	1	2	1	1
EVMSG20 6/7.5	1	1	4	1	1	1	1	6	1	1	9	1	1	/	1	2	1	1	1	1	4	6	1	1	1	1	2	1	1
EVMSG20 7/11	1	1	4	2	1	1	1	7	1	1	9	2	2	/	2	2	1	1	2	1	4	7	1	1	1	1	2	1	1
EVMSG20 8/11	1	1	5	2	1	1	1	8	1	1	11	2	2	/	2	2	1	1	2	1	4	8	1	1	1	1	2	1	1
EVMSG20 9/11	1	1	6	2	1	1	1	9	1	1	13	2	2	/	2	2	1	1	2	1	4	9	1	1	1	1	2	1	1
EVMSG20 10/11	1	1	7	2	1	1	1	10	1	1	15	2	2	/	2	2	1	1	2	1	4	10	1	1	1	1	2	1	1
EVMSG20 11/15	1	1	8	2	1	1	1	11	1	1	17	2	2	/	2	2	1	1	2	1	4	11	1	1	1	1	2	1	1
EVMSG20 12/15	1	1	9	2	1	1	1	12	1	1	19	2	2	/	2	2	1	1	2	1	4	12	1	1	1	1	2	1	1
EVMSG20 13/15	1	1	10	2	1	1	1	13	1	1	21	2	2	/	2	2	1	1	2	1	4	13	1	1	1	1	2	1	1
EVMSG20 14/18.5	1	1	11	2	1	1	1	14	1	1	23	2	2	/	2	2	1	1	2	1	4	14	1	1	1	1	2	1	1
EVMSG20 15/18.5	1	1	12	2	1	1	1	15	1	1	25	2	2	/	2	2	1	1	2	1	4	15	1	1	1	1	2	1	1
EVMSG20 16/18.5	1	1	13	2	1	1	1	16	1	1	27	2	2	/	2	2	1	1	2	1	4	16	1	1	1	1	2	1	1

Pump Type	N°																						
	117*	120-1	120-3	120-6	120-11*	120-13	128-1	128-3	128-6	130-1	130-2	131-1	135-1	135-6	137-1	140	162	212	212-1	212-2	219*	245	273-1
EVMSG20 1/1.5	2	4	4	4	4	4	4	/	4	3	4	1	4	4	1	2	1	1	4	1	2	2	4
EVMSG20 2/3.0	2	4	4	4	4	4	4	/	4	3	4	1	4	4	1	2	1	1	4	1	2	2	4
EVMSG20 3/4.0	2	4	4	4	4	4	4	/	4	3	4	1	4	4	1	2	1	1	4	1	2	2	4
EVMSG20 4/5.5	2	4	4	4	4	4	4	/	3	4	1	4	/	1	2	1	1	4	1	2	2	4	
EVMSG20 5/7.5	2	4	4	4	4	4	4	/	3	4	1	4	/	1	2	1	1	4	1	2	2	4	
EVMSG20 6/7.5	2	4	4	4	4	4	4	/	3	4	1	4	/	1	2	1	1	4	1	2	2	4	
EVMSG20 7/11	2	4	4	4	4	4	4	/	3	4	1	4	/	1	2	1	1	4	1	2	2	4	
EVMSG20 8/11	2	4	4	4	4	4	4	/	3	4	1	4	/	1	2	1	1	4	1	2	2	4	
EVMSG20 9/11	2	4	4	4	4	4	4	/	3	4	1	4	/	1	2	1	1	4	1	2	2	4	
EVMSG20 10/11	/	4	4	4	/	4	4	4	/	3	4	1	4	/	1	2	1	1	4	1	/	2	4
EVMSG20 11/15	/	4	4	4	/	4	4	4	/	3	4	1	4	/	1	2	1	1	4	1	/	2	4
EVMSG20 12/15	/	4	4	4	/	4	4	4	/	3	4	1	4	/	1	2	1	1	4	1	/	2	4
EVMSG20 13/15	/	4	4	4	/	4	4	4	/	3	4	1	4	/	1	2	1	1	4	1	/	2	4
EVMSG20 14/18.5	/	4	4	4	/	4	4	4	/	3	4	1	4	/	1	2	1	1	4	1	/	2	4
EVMSG20 15/18.5	/	4	4	4	/	4	4	4	/	3	4	1	4	/	1	2	1	1	4	1	/	2	4
EVMSG20 16/18.5	/	4	4	4	/	4	4	4	/	3	4	1	4	/	1	2	1	1	4	1	/	2	4

* only for Oval flange (N)

*** shaft in EN 1.4462 (AISI 329A)

128-6 / 135-6 : with Aluminium coupling (see drawing pag.211)

PACKING DRAWING
EVMS(.)1-3-5-10-15-20

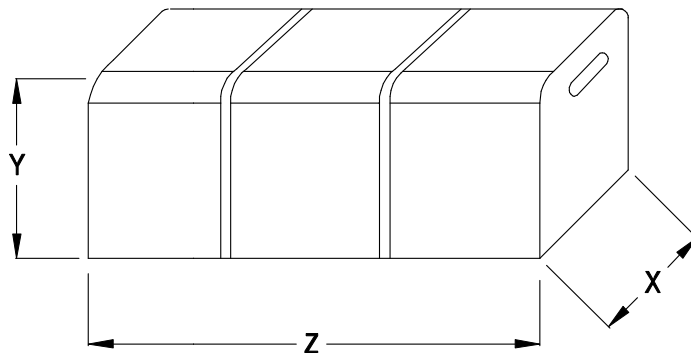

TYPE 1

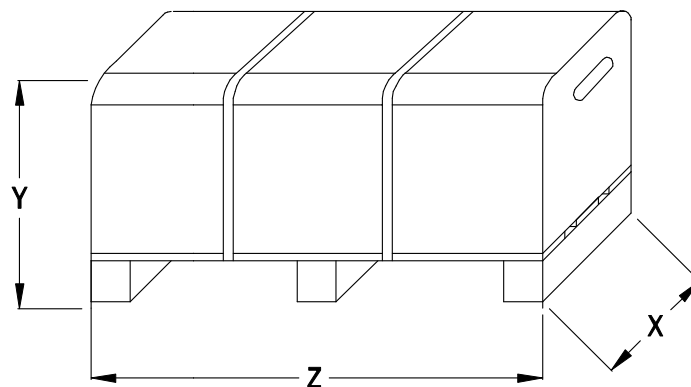

TYPE 2

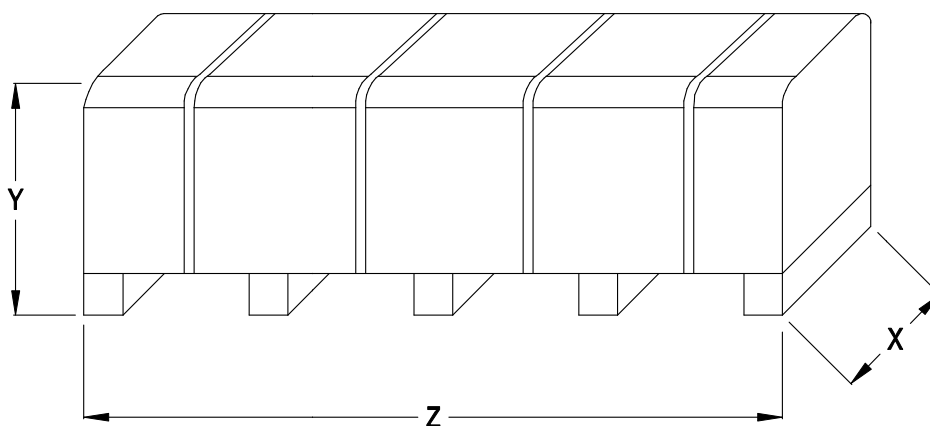

TYPE 3

PACKING DATA EVMS(.)1-3-5

Pump type	Pumps						Pumps with motor ~1						Pumps with motor ~3						
	Packing [mm]			Weight + Packing [kg]		Pack Type	Packing [mm]			Weight + Packing [kg]		Pack Type	Packing [mm]			Weight + Packing [kg]		Pack Type	
	X	Y	Z	EVMS(L)	EVMSG		X	Y	Z	EVMS(L)	EVMSG		X	Y	Z	EVMS(L)	EVMSG		
1	EVMS(.)1 2/0.37	385	400	385	12.3	19.3	1	385	400	585	20.2	27.2	1	385	400	585	18.9	25.9	1
	EVMS(.)1 3/0.37	385	400	385	12.8	19.8	1	385	400	585	20.7	27.7	1	385	400	585	19.4	26.4	1
	EVMS(.)1 4/0.37	385	400	385	13.2	20.2	1	385	400	770	21.5	28.4	1	385	400	770	20.2	27.1	1
	EVMS(.)1 5/0.37	385	400	585	14.2	21.2	1	385	400	770	22.0	28.9	1	385	400	770	20.7	27.6	1
	EVMS(.)1 6/0.37	385	400	585	14.6	21.6	1	385	400	770	22.4	29.3	1	385	400	770	21.1	28.0	1
	EVMS(.)1 7/0.37	385	400	585	15.0	22.0	1	385	400	770	22.8	29.7	1	385	400	770	21.5	28.4	1
	EVMS(.)1 8/0.37	385	400	585	15.5	22.5	1	385	400	770	23.3	30.2	1	385	400	770	22.0	28.9	1
	EVMS(.)1 9/0.55	385	400	585	15.9	22.9	1	385	400	770	25.1	32.0	1	385	400	770	22.8	29.7	1
	EVMS(.)1 10/0.55	385	400	585	16.3	23.3	1	385	400	770	25.5	32.4	1	385	400	770	23.2	30.1	1
	EVMS(.)1 11/0.55	385	400	585	16.8	23.8	1	385	400	770	26.0	32.9	1	385	400	770	23.7	30.6	1
	EVMS(.)1 12/0.55	385	400	585	17.5	24.5	1	385	400	770	26.7	33.6	1	385	400	970	24.4	31.3	1
	EVMS(.)1 13/0.55	385	400	585	18.1	25.1	1	385	400	970	27.9	34.9	1	385	400	970	25.6	32.6	1
	EVMS(.)1 14/0.75	385	400	770	19.3	26.3	1	385	400	970	31.5	38.5	1	385	400	970	29.6	36.6	1
	EVMS(.)1 16/0.75	385	400	770	20.3	27.3	1	385	400	970	32.5	39.5	1	385	400	970	30.6	37.6	1
	EVMS(.)1 18/1.1	385	400	770	21.4	28.4	1	385	400	970	34.0	41.0	1	385	400	970	33.3	40.3	1
	EVMS(.)1 20/1.1	385	400	770	22.4	29.4	1	385	400	970	35.0	42.0	1	385	400	970	34.3	41.3	1
	EVMS(.)1 22/1.1	385	400	770	23.6	30.6	1	385	400	1170	36.8	43.7	1	385	400	1170	36.1	43.0	1
	EVMS(.)1 24/1.1	385	400	970	25.0	32.0	1	385	400	1170	37.8	44.7	1	385	400	1170	37.1	44.0	1
	EVMS(.)1 26/1.1	385	400	970	26.0	33.0	1	385	400	1170	38.8	45.7	1	385	400	1170	38.1	45.0	1
	EVMS(.)1 27/1.5	385	400	970	26.4	33.4	1	400	510	1200	45.2	61.1	1 2	385	400	1170	41.4	48.3	1
	EVMS(.)1 29/1.5	385	400	970	27.4	34.4	1	500	525	1350	66.1	73.0	3	500	525	1350	62.3	69.2	3
	EVMS(.)1 32/1.5	385	400	1170	29.3	36.2	1	500	525	1350	67.4	74.3	3	500	525	1350	63.6	70.5	3
	EVMS(.)1 34/1.5	385	400	1170	30.2	37.1	1	500	525	1350	68.3	75.2	3	500	525	1350	64.5	71.4	3
	EVMS(.)1 37/2.2	385	400	1170	31.6	38.5	1	500	525	1540	74.1	81.9	3	500	525	1540	69.5	77.2	3
EVMS(.)1 39/2.2	385	400	1170	32.6	39.5	1	500	525	1540	75.1	82.1	3	500	525	1540	68.9	75.8	3	
3	EVMS(.)3 2/0.37	385	400	385	12.4	17.6	1	385	400	600	20.3	25.5	1	385	400	585	19.0	24.2	1
	EVMS(.)3 3/0.37	385	400	385	12.8	18.0	1	385	400	600	20.7	25.9	1	385	400	585	19.4	24.6	1
	EVMS(.)3 4/0.37	385	400	385	13.2	18.5	1	385	400	770	21.5	26.8	1	385	400	770	20.2	25.5	1
	EVMS(.)3 5/0.55	385	400	585	14.2	19.4	1	385	400	770	23.4	28.6	1	385	400	770	21.1	26.3	1
	EVMS(.)3 6/0.55	385	400	585	14.6	19.8	1	385	400	770	23.8	29.0	1	385	400	770	21.5	26.7	1
	EVMS(.)3 7/0.75	385	400	585	15.5	20.7	1	385	400	770	27.6	32.8	1	385	400	770	25.7	30.9	1
	EVMS(.)3 8/0.75	385	400	585	16.0	21.2	1	385	400	770	28.1	33.3	1	385	400	770	26.2	31.4	1
	EVMS(.)3 9/1.1	385	400	585	16.4	21.6	1	385	400	770	28.9	34.1	1	385	400	770	28.2	33.4	1
	EVMS(.)3 10/1.1	385	400	585	16.9	22.1	1	385	400	770	29.4	34.6	1	385	400	770	28.7	33.9	1
	EVMS(.)3 11/1.1	385	400	585	17.3	22.5	1	385	400	970	30.4	35.6	1	385	400	970	29.8	34.9	1
	EVMS(.)3 12/1.1	385	400	585	18.0	23.2	1	385	400	970	31.1	36.3	1	385	400	970	30.4	35.6	1
	EVMS(.)3 13/1.5	385	400	770	19.0	24.2	1	385	400	970	37.6	42.8	1	385	400	970	33.8	38.7	1
	EVMS(.)3 14/1.5	385	400	770	19.4	24.6	1	385	400	970	38.0	43.2	1	385	400	970	34.2	39.4	1
	EVMS(.)3 15/1.5	385	400	770	19.9	25.1	1	385	400	970	38.5	43.7	1	385	400	970	34.7	39.9	1
	EVMS(.)3 16/1.5	385	400	770	20.9	26.1	1	385	400	970	39.6	44.7	1	385	400	970	35.7	40.7	1
	EVMS(.)3 17/2.2	385	400	770	21.4	26.6	1	385	400	970	41.7	46.9	1	385	400	970	38.2	43.4	1
	EVMS(.)3 19/2.2	385	400	770	22.4	27.6	1	385	400	1170	43.3	48.5	1	385	400	1170	39.8	45.0	1
	EVMS(.)3 21/2.2	385	400	770	23.3	28.5	1	385	400	1170	44.2	49.0	1	385	400	1170	40.7	45.9	1
	EVMS(.)3 23/2.2	385	400	970	24.7	29.9	1	385	400	1170	45.2	49.4	1	385	400	1170	41.7	46.9	1
	EVMS(.)3 24/2.2	385	400	970	25.1	30.4	1	385	400	1170	45.6	49.8	1	385	400	1170	42.1	47.3	1
	EVMS(.)3 25/3.0	385	400	970	25.7	30.9	1	-	-	-	-	-	-	400	510	1200	49.5	63.7	1 2
	EVMS(.)3 27/3.0	385	400	970	26.7	31.9	1	-	-	-	-	-	-	500	525	1350	70.4	75.6	3
	EVMS(.)3 29/3.0	385	400	970	27.6	32.9	1	-	-	-	-	-	-	500	525	1350	71.3	76.6	3
	EVMS(.)3 31/3.0	385	400	1170	29.2	34.4	1	-	-	-	-	-	-	500	525	1350	72.3	77.5	3
EVMS(.)3 33/3.0	385	400	1170	30.0	35.2	1	-	-	-	-	-	-	500	525	1350	73.1	78.3	3	
5	EVMS(.)5 2/0.37	385	400	385	12.9	19.4	1	385	400	600	20.8	27.3	1	385	400	585	19.5	26.0	1
	EVMS(.)5 3/0.55	385	400	385	13.4	19.9	1	385	400	770	23.1	29.5	1	385	400	770	20.8	27.3	1
	EVMS(.)5 4/0.75	385	400	585	14.9	21.4	1	385	400	770	27.0	33.4	1	385	400	770	25.1	31.6	1
	EVMS(.)5 5/1.1	385	400	585	15.5	21.9	1	385	400	770	27.9	34.4	1	385	400	770	27.2	33.7	1
	EVMS(.)5 6/1.5	385	400	585	16.1	22.5	1	385	400	770	34.6	41.0	1	385	400	770	30.8	34.3	1
	EVMS(.)5 7/1.5	385	400	585	16.5	22.9	1	385	400	970	35.6	42.0	1	385	400	970	31.8	38.2	1
	EVMS(.)5 8/2.2	385	400	585	17.0	23.5	1	385	400	970	37.8	44.3	1	385	400	970	34.3	40.8	1
	EVMS(.)5 9/2.2	385	400	585	17.6	24.0	1	385	400	970	38.4	44.8	1	385	400	970	34.9	41.3	1
	EVMS(.)5 10/2.2	385	400	770	18.5	25.0	1	385	400	970	38.8	45.3	1	385	400	970	35.3	41.8	1
	EVMS(.)5 11/2.2	385	400	770	19.4	25.8	1	385	400	970	39.7	46.1	1	385	400	970	36.2	42.6	1
	EVMS(.)5 12/3.0	385	400	770	20.6	27.0	1	-	-	-	-	-	-	385	400	970	44.5	49.9	1
	EVMS(.)5 13/3.0	385	400	770	21.2	27.6	1	-	-	-	-	-	-	400	510	1200	45.4	60.8	1 2
	EVMS(.)5 14/3.0	385	400	770	21.7	28.2	1	-	-	-	-	-	-	400	510	1200	45.9	61.4	1 2
	EVMS(.)5 15/3.0	385	400	770	22.8	29.2	1	-	-	-	-	-	-	400	510	1200	47.0	62.4	1 2
	EVMS(.)5 17/4.0	385	400	970	23.9	30.3	1	-	-	-	-	-	-	400	510	1200	60.4	66.8	2
	EVMS(.)5 19/4.0	385	400	970	25.0	31.4	1	-	-	-	-	-	-	400	510	1200	61.5	67.9	2
	EVMS(.)5 20/4.0	385	400	970	27.3	33.7	1	-	-	-	-	-	-	500	525	1350	74.6	81.0	3
	EVMS(.)5 23/5.5	385	400	1170	34.5	40.9	1	-	-	-	-	-	-	500	525	1540	96.1	102.5	3
	EVMS(.)5 25/5.5	385	400	1170	35.5	41.9	1	-	-	-	-	-	-	500	525	1540	97.1	103.5	3
	EVMS(.)5 27/5.5	500	525	1350	57.3	63.8	3	-	-	-	-	-	-	500	525	1540	98.6	105.1	3

PACKING DATA
EVMS(.)10-15-20

EVMS - PACKING DATA

Pump type	Pumps						Pumps with motor ~1						Pumps with motor ~3						
	Packing [mm]			Weight + Packing [kg]		Pack Type	Packing [mm]			Weight + Packing [kg]		Pack Type	Packing [mm]			Weight + Packing [kg]		Pack Type	
	X	Y	Z	EVMS(L)	EVMSG		X	Y	Z	EVMS(L)	EVMSG		X	Y	Z	EVMS(L)	EVMSG		
10	EVMS(.)10 2/0.75	385	400	585	19.9	26.7	1	385	400	770	32.0	38.8	1	385	400	770	30.1	36.9	1
	EVMS(.)10 3/1.5	385	400	585	20.9	27.7	1	385	400	770	39.4	46.2	1	385	400	770	35.6	42.4	1
	EVMS(.)10 4/2.2	385	400	585	21.7	28.4	1	385	400	770	41.9	48.6	1	385	400	770	38.4	45.1	1
	EVMS(.)10 5/2.2	385	400	585	22.5	29.3	1	385	400	970	43.3	49.4	1	385	400	970	39.8	46.6	1
	EVMS(.)10 6/2.2	385	400	585	23.4	30.1	1	385	400	970	44.2	50.0	1	385	400	970	40.7	47.4	1
	EVMS(.)10 7/3.0	385	400	585	24.3	31.1	1	-	-	-	-	-	-	400	510	1200	48.4	64.8	1 2
	EVMS(.)10 8/3.0	385	400	770	25.7	32.4	1	-	-	-	-	-	-	400	510	1200	49.3	65.6	1 2
	EVMS(.)10 9/4.0	385	400	770	26.5	33.3	1	-	-	-	-	-	-	400	510	1200	63.4	70.2	2
	EVMS(.)10 10/4.0	385	400	770	27.4	34.1	1	-	-	-	-	-	-	400	510	1200	64.2	71.0	2
	EVMS(.)10 11/4.0	385	400	770	29.0	35.8	1	-	-	-	-	-	-	400	510	1200	65.9	72.7	2
	EVMS(.)10 12/5.5	385	400	970	39.2	46.0	1	-	-	-	-	-	-	400	510	1200	87.8	94.6	2
	EVMS(.)10 14/5.5	385	400	970	41.0	47.8	1	-	-	-	-	-	-	500	525	1350	100.5	107.3	3
	EVMS(.)10 15/5.5	385	400	970	41.9	48.7	1	-	-	-	-	-	-	500	525	1350	101.4	108.2	3
	EVMS(.)10 16/7.5	385	400	970	42.9	49.6	1	-	-	-	-	-	-	500	525	1350	104.2	110.9	3
	EVMS(.)10 18/7.5	400	510	1200	45.3	60.6	1 2	-	-	-	-	-	-	500	525	1540	108.5	114.8	3
	EVMS(.)10 19/7.5	400	510	1200	46.2	62.0	1 2	-	-	-	-	-	-	500	525	1540	109.9	116.7	3
	EVMS(.)10 21/7.5	400	510	1200	48.0	63.8	1 2	-	-	-	-	-	-	500	525	1540	111.4	118.2	3
	EVMS(.)10 22/11	400	510	1200	59.3	66.1	2	-	-	-	-	-	-	610	525	1750	136.1	142.9	3
	EVMS(.)10 23/11	500	525	1350	76.8	83.6	3	-	-	-	-	-	-	610	525	1750	142.0	148.8	3
	15	EVMS(.)15 1/1.1	385	400	585	21.2	29.3	1	385	400	770	33.7	41.8	1	385	400	770	33.0	41.1
EVMS(.)15 2/2.2		385	400	585	21.5	29.6	1	385	400	770	41.7	49.8	1	385	400	770	38.2	46.3	1
EVMS(.)15 3/3.0		385	400	585	22.8	30.9	1	-	-	-	-	-	-	400	510	1200	46.9	64.6	1 2
EVMS(.)15 4/4.0		385	400	585	24.0	32.1	1	-	-	-	-	-	-	400	510	1200	60.2	69.5	2
EVMS(.)15 5/5.5		385	400	770	34.2	42.4	1	-	-	-	-	-	-	400	510	1200	83.2	91.4	2
EVMS(.)15 6/5.5		385	400	770	35.4	43.6	1	-	-	-	-	-	-	400	510	1200	84.4	92.6	2
EVMS(.)15 7/7.5		385	400	770	37.6	45.8	1	-	-	-	-	-	-	400	510	1200	88.4	96.6	2
EVMS(.)15 8/7.5		385	400	970	39.4	47.5	1	-	-	-	-	-	-	400	510	1200	89.7	97.9	2
EVMS(.)15 9/11		400	510	1200	45.4	63.0	1 2	-	-	-	-	-	-	500	525	1350	125.2	133.2	3
EVMS(.)15 10/11		400	510	1200	47.7	65.3	1 2	-	-	-	-	-	-	500	525	1540	127.8	136.0	3
EVMS(.)15 11/11		400	510	1200	49.9	67.6	1 2	-	-	-	-	-	-	500	525	1540	135.3	144.4	3
EVMS(.)15 12/11		400	510	1200	60.8	68.9	2	-	-	-	-	-	-	500	525	1540	137.3	145.4	3
EVMS(.)15 13/11		400	510	1200	62.1	70.2	2	-	-	-	-	-	-	500	525	1540	138.6	146.7	3
EVMS(.)15 15/15		400	510	1200	64.7	72.8	2	-	-	-	-	-	-	610	525	1750	167.6	175.3	3
EVMS(.)15 17/15	500	525	1350	78.9	87.0	3	-	-	-	-	-	-	610	525	1750	170.5	178.6	3	
20	EVMS(.)20 1/1.5	385	400	585	21.4	29.6	1	385	400	770	39.7	44.9	1	385	400	770	39.0	44.2	1
	EVMS(.)20 2/3.0	385	400	585	22.0	30.2	1	-	-	-	-	-	-	385	400	770	45.0	49.5	1
	EVMS(.)20 3/4.0	385	400	585	22.9	31.1	1	-	-	-	-	-	-	400	510	1200	50.0	68.5	1 2
	EVMS(.)20 4/5.5	385	400	770	29.3	37.5	1	-	-	-	-	-	-	400	510	1200	78.3	86.5	2
	EVMS(.)20 5/7.5	385	400	770	30.6	38.8	1	-	-	-	-	-	-	400	510	1200	81.4	89.6	2
	EVMS(.)20 6/7.5	385	400	770	31.8	40.0	1	-	-	-	-	-	-	400	510	1200	82.6	90.8	2
	EVMS(.)20 7/11	385	400	970	40.0	48.2	1	-	-	-	-	-	-	500	525	1350	119.3	127.5	3
	EVMS(.)20 8/11	400	510	1200	46.3	64.1	1 2	-	-	-	-	-	-	500	525	1350	129.7	137.9	3
	EVMS(.)20 9/11	400	510	1200	47.6	65.4	1 2	-	-	-	-	-	-	500	525	1350	131.0	139.2	3
	EVMS(.)20 10/11	400	510	1200	49.0	66.8	1 2	-	-	-	-	-	-	500	525	1540	134.9	143.1	3
	EVMS(.)20 11/15	400	510	1200	50.0	68.1	1 2	-	-	-	-	-	-	500	525	1540	162.8	171.0	3
	EVMS(.)20 12/15	400	510	1200	61.2	69.4	2	-	-	-	-	-	-	500	525	1540	164.1	172.3	3
	EVMS(.)20 13/15	400	510	1200	62.5	70.8	2	-	-	-	-	-	-	500	525	1540	165.4	173.7	3
	EVMS(.)20 14/18.5	400	510	1200	63.9	72.1	2	-	-	-	-	-	-	610	525	1750	181.9	190.0	3
	EVMS(.)20 15/18.5	400	510	1200	65.2	73.4	2	-	-	-	-	-	-	610	525	1750	183.2	191.4	3
	EVMS(.)20 16/18.5	400	510	1200	66.5	74.7	2	-	-	-	-	-	-	610	525	1750	184.5	192.7	3

EVM

PRODUCT FEATURES

[General]

1. Pump Type

The EVM is Non-self-priming, vertical multistage in line, centrifugal pumps.

2. Model range

The EVM comes in **32,45 and 64 m³/h flow sizes** for the majority market needs.

3. Maximum operating pressure

The EVM can be operated at **16,25 or 30 bar as maximum**.

4. Operating temperature range

The EVM can be operated **from - 15 to + 120 °C** as the maximum.

5. Material options



AISI 304, AISI 316 and Cast iron versions are available.

6. Motor

The EVM can be coupled with **the commercial motors** that are acquired in the markets.

The EVM can be provided as the electric pump with IE2 motor from 2.2 kW up to 5.5 kW (IE3 on request) and IE3 motor for the over 7.5 kW.

7. Certifications

	DM174/2004  prodotto conforme D.M.174/2004	ACS  ATTESTAZIONE DI CONFORMITÀ SANITARIA
Drinking water approval		
<u>Mechanical seal</u>	SiC/Carbon_FPM	SiC/Carbon_FPM
EVMG	•	-
EVM	•	•
EVML	•	-

• Standard

8. Conform to the provisions of the European directives



[Main Product Features]

1. Robust constructions

- **Commercial motors** can be fitted to all of the pump models with additional ball bearing on the bracket.
- **Stainless cast** bottom casing to ensure 30 bar working pressure
- **Rolling groove pump shaft** for high torque transmissions

2. Energy saving

- **High efficiency IE2 and IE3 motor** complied with the EuP 2005/32/EC and ErP 2009/125/EC directives.
- **The VFD (Variable frequency drive)** can be fitted on the motor for the pressure boosting systems.

3. Easy maintenance

The **cartridge shaft seal** enables the **plug in replacement** of the shaft seal without disassembling the motor bracket

PRODUCT SPECIFICATIONS EVM(.)32-45-64

PUMP											
Version		EVMG			EVM			EVML			
Operating range	Nominal flow rate (m ³ /h)	32	45	64	32	45	64	32	45	64	
	Maximum working pressure	1.6 / 3.0 MPa (16 bar/ 30 bar)									
	Liquid temperature range	-15°C to 120°C									
Key Components Material	Impeller	EN 1.4301 (AISI 304)						EN 1.4401 (AISI 316)			
	Intermediate casing	EN 1.4301 (AISI 304)						EN 1.4401 (AISI 316)			
	Liner ring	EVM 32	EN 1.4301 (AISI 304) + PTFE						EN 1.4401 (AISI 316) + PTFE		
		EVM 45-64	EN 1.4401 (AISI 316) + PTFE								
	Bottom casing	Cast Iron			ASTMCF8			ASTMCF8M			
	Casing cover	Cast Iron			Cast Iron + EN 1.4301 (AISI 304)			Cast Iron + EN 1.4401 (AISI 316)			
	Shaft	EN 1.4301 (AISI 304)	●	●	●	●	●	●	●	●	
		EN 1.4404 (AISI 316L)									
	Shaft sleeve bearing	Tungstene carbide									
	Shaft Seal	type	Cartridge mechanical seal								
		material	Silicon Carbide / Carbon / FPM								
	O-ring	EPDM						FPM			
	Outer casing	EN 1.4301 (AISI 304)						EN 1.4404 (AISI 316L)			
	Motor Bracket	Cast Iron									
Tie rod	Carbon Steel										
Coupling	Carbon Steel										
Base	Cast Iron										
Pipe connection	Round Flange (DIN)	●	●	●	●	●	●	●	●		

Legend: ● Standard

MOTOR		
Power Source	Frequency	50 Hz
	Phase	Three Phase
	Rotation speed	≈ 2900 min ⁻¹
	Power rating	2.2 ÷ 37 kW
		3.0 ÷ 50 HP
Voltage	230/400 ± 10% V (up to 4kW) 400/690 ± 10% V (above 5.5 kW)	
Type	Type	Electric - TEFC
	Efficiency Level	IE2 from 2.2 kW up to 5.5 kW (IE3 on request) IE3 above 7.5 kW
	No' of poles	2
	Protection degree	IP 55
	Insulation Class	F (temperature rise class B)
Others	Thermal Protection	PTC
	Casing Material	Aluminium
	Flange mount (IEC motor)	IM B14 (up to 4 kW) IM B5 (above 5.5 kW)

**SHAFT SEAL
EVM(.)32-45-64**

1. Shaft Seal

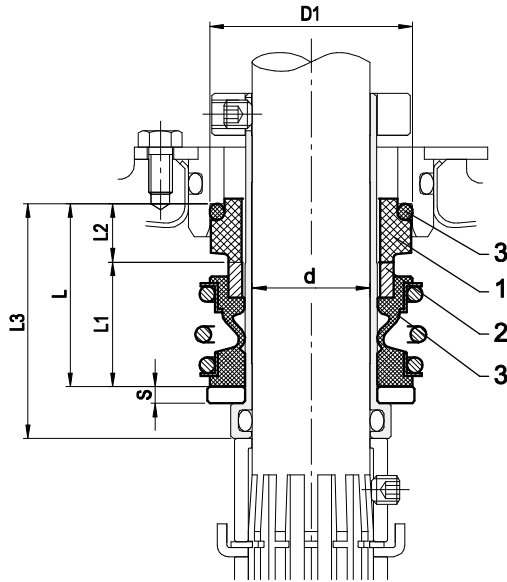

up to 25 bar
Cartridge Unbalanced type

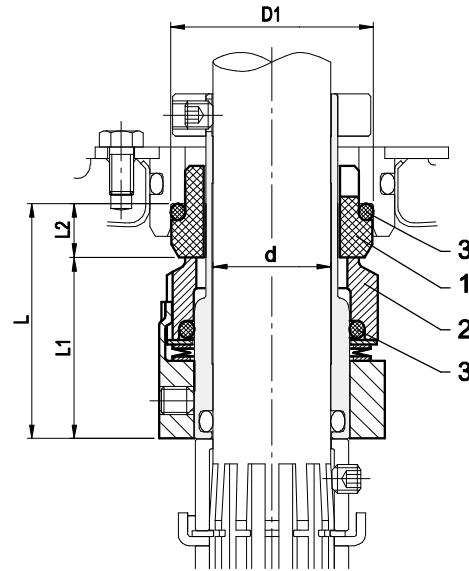

from 25 to 30 bar
Cartridge Balanced type

2. Type of Shaft Seal and Dimensions [mm]

Size [mm]	Max operating pressure [bar]	d [mm]	D ₁ [mm]	L [mm]	L ₁ [mm]	L ₂ [mm]	L ₃ [mm]	S [mm]	Material		
									1 Stationary Seal Ring	2 Rotary Seal Ring	3 Rubber
25	25	25	43	39	26.5	12.5	50	3.5	Carbon graphite	Silicon carbide	FPM
	30			50	38.5	11.5	-	-			

TYPE KEY EVM(.)32-45-64

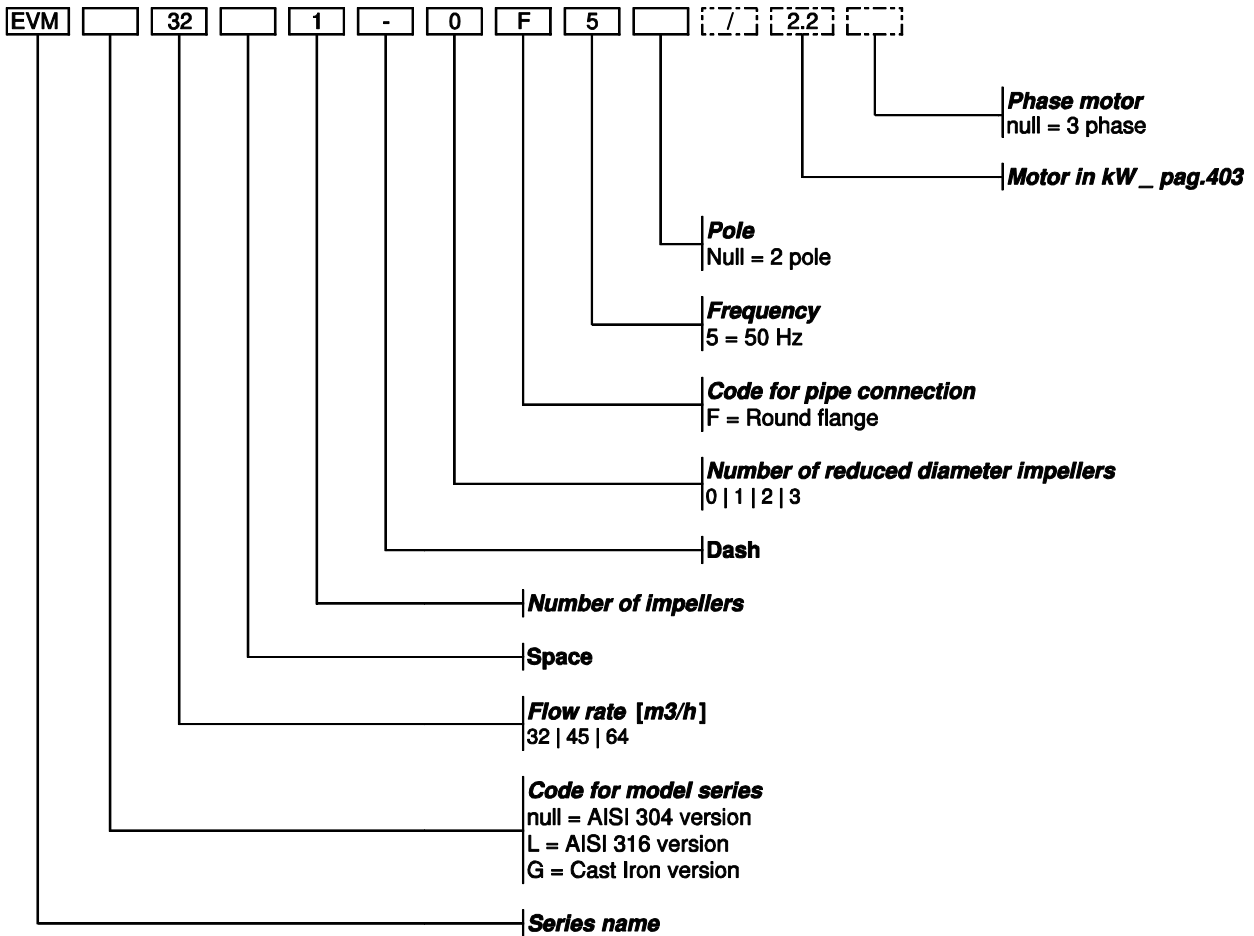

Example for **pump without motor**
EVM32 1-0F5

Example for **pump with motor**
EVM32 1-0F5/2.2

NAMEPLATE

		P.IVA 01234560221 EBARA Via Campo Sportivo, 30 38023 Cles (TN) - ITALY			
TYPE	①	N	⑪		
H _{max}	④	m	H _{min}	⑤	m
Q	②	m ³ /min	H	③	m
P2	⑥	KW	Hz	⑧	min ⁻¹ ⑨
HP	⑦	PN [*]	⑩		
MEI >	⑫	Hyd. eff.	⑬	%	

- 1) "TYPE" Pump model
- 2) "Q" Indicates upper and lower flow rate limits
- 3) "H" Indicates head limits corresponding to minimum and maximum flow rate
- 4) "H_{max}" Maximum head
- 5) "H_{min}" Minimum head
- 6) "P2" Rated power of the motor (output at shaft)
- 7) "HP" Rated power of the motor expressed in HP (Horse Power)
- 8) "Hz" Frequency
- 9) "min⁻¹" Speed of rotation
- 10) "P/N^{*}" Pump item number
- 11) "N" Material code
- 12) "MEI" Index of the pump's quality in relation to its efficiency
- 13) "Hyd. Eff. " Hydraulic efficiency of the pump

PERFORMANCE RANGE
EVM(.)32-45-64

EVM PERFORMANCE RANGE

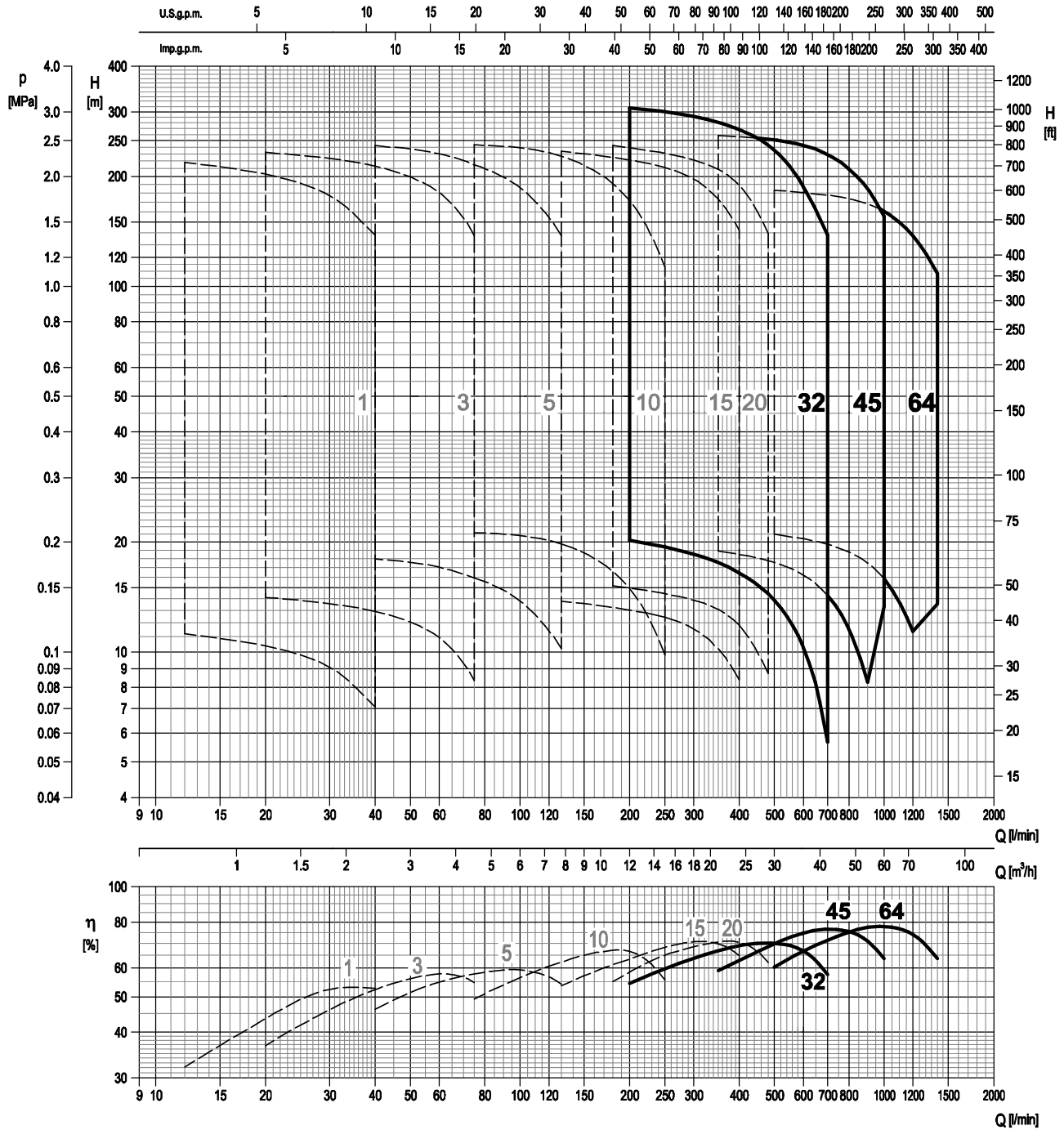

CURVE SPECIFICATIONS

The specifications below qualify the curves shown on the following pages.

Tolerances according to ISO 9906:2012 - Grade 3B.

The curves refer to effective speed of asynchronous motors at 50 Hz, 2 poles.

Measurements were carried out with clean water at 20°C of temperature and with a kinematic viscosity of $\nu = 1 \text{ mm}^2/\text{s}$ (1 cSt).

The NPSH curve is an average curve obtained in the same conditions of performance curves.

During the pump selection, consider to get a safety margin of at least 0.5 m.

The continuous curves indicate the recommended working range. The dotted curve is only a guide.

In order to avoid the risk of over-heating, the pumps should not be used at a flow rate below 10% of best efficiency point.

Symbols explanation:

Q	=	volume flow rate
H	=	total head
P_2	=	pump power input (shaft power)
η	=	pump efficiency
NPSH	=	net positive suction head required by the pump
MEI	=	minimum efficiency index

The minimum efficiency index (MEI) is a measure of the quality of a pump size in respect to its mean efficiency. The minimum efficiency index is based on the hydraulic efficiency and on the head at the best efficiency point.

The efficiency of a pump with trimmed impeller is usually lower than that of a pump with the full impeller diameter. The trimming of the impeller will adapt the pump to a fixed duty point, leading to a reduced energy consumption. The minimum efficiency index (MEI) is based on the full impeller diameter.

The operation of these water pumps with variable duty points may be more efficient and economical when controlled, for example by the use of a variable speed drive that matches the pump duty to the system

Minimum efficiency index (MEI)

Pump type	MEI
EVM(.)32	> 0.40
EVM(.)45	> 0.70
EVM(.)64	> 0.70

SELECTION CHART
EVM(.)32-45-64

Pump Type	Motor kW	Motor HP	Size	Maximum working pressure [Mpa]	Q=Capacity																																	
					l/min		200		350		500		600		700		900		1000		1200		1400															
					0	12	21	30	36	42	54	60	72	84																								
Three phase					H=Total manometric head in meters																																	
32	EVM(.)32 1-0F5/2.2	2.2	3	90 L	1.6	24	21.7	19.6	16.4	13.2	9.7	-	-	-	-	-	-	-	-	-	-	-	-															
						39.8	36.9	31.6	23.5	17.4	-	-	-	-	-	-	-	-	-	-	-	-	-	-	-	-												
						45	EVM(.)45 1-1F5/3.0	3.0	4	100 L	1.6	21	-	18.9	17.6	16.3	14.3	8.3	-	-	-	-	-	-	-	-	-	-	-									
												27	-	25.6	24.6	23.5	21.8	16.7	13.3	-	-	-	-	-	-	-	-	-	-	-	-	-						
												64	EVM(.)64 1-1F5/4.0	4.0	5.5	100 L	1.6	23.7	-	-	21	20.4	19.7	17.5	15.9	11.4	-	-	-	-	-	-	-	-	-			
																		29.3	-	-	26.6	26.1	25.4	23.7	22.3	18.5	13.5	-	-	-	-	-	-	-	-	-	-	-

1.6 MPa=16 bar ; 2.5 MPa=25 bar ; 3.0 MPa=30 bar

307

PERFORMANCE CURVE EVM(L)32

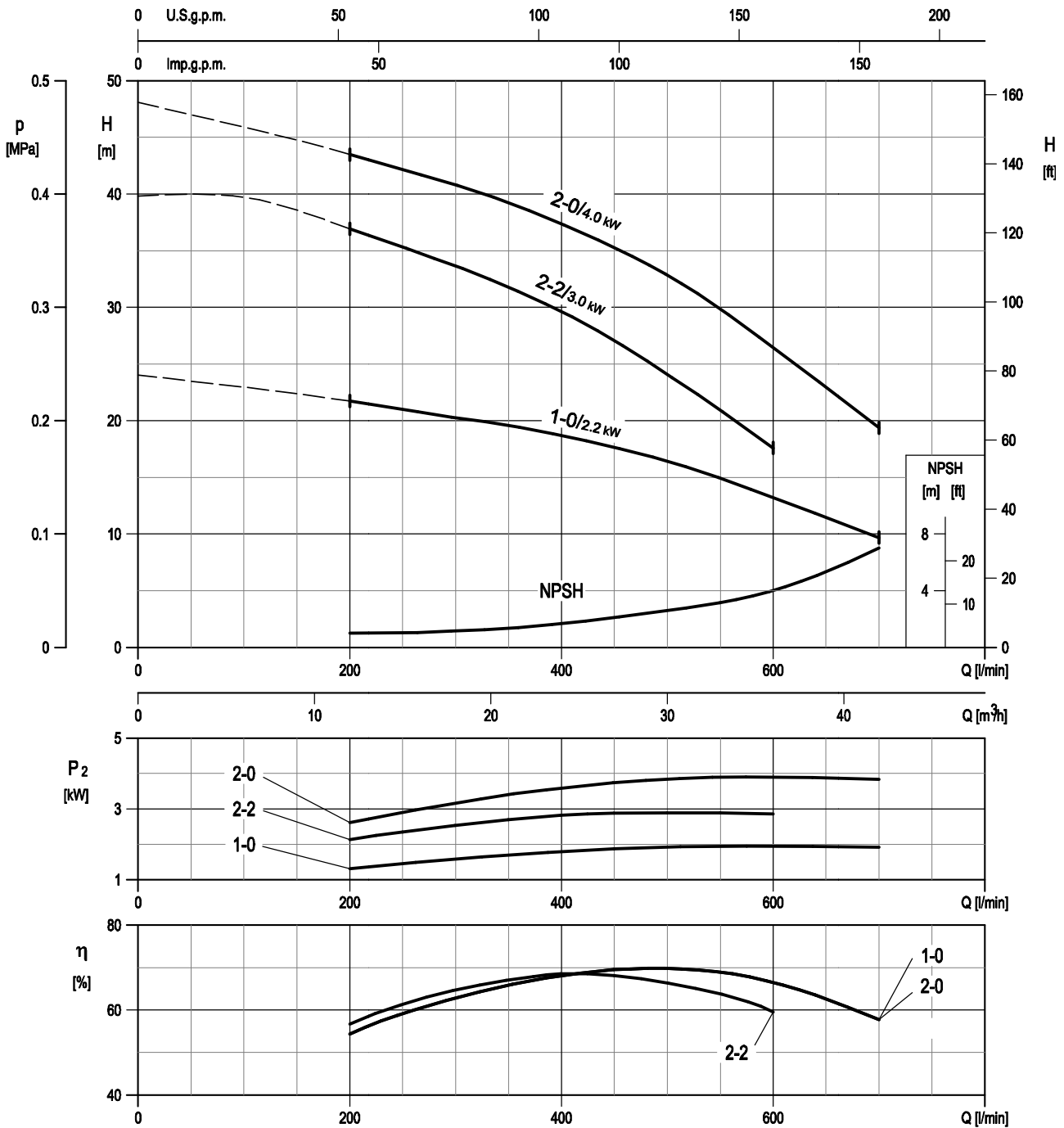

Rotation speed $\approx 2900 \text{ min}^{-1}$
 Test standard: ISO 9906:2012 - Grade 3B

PERFORMANCE CURVE
EVM(L)32

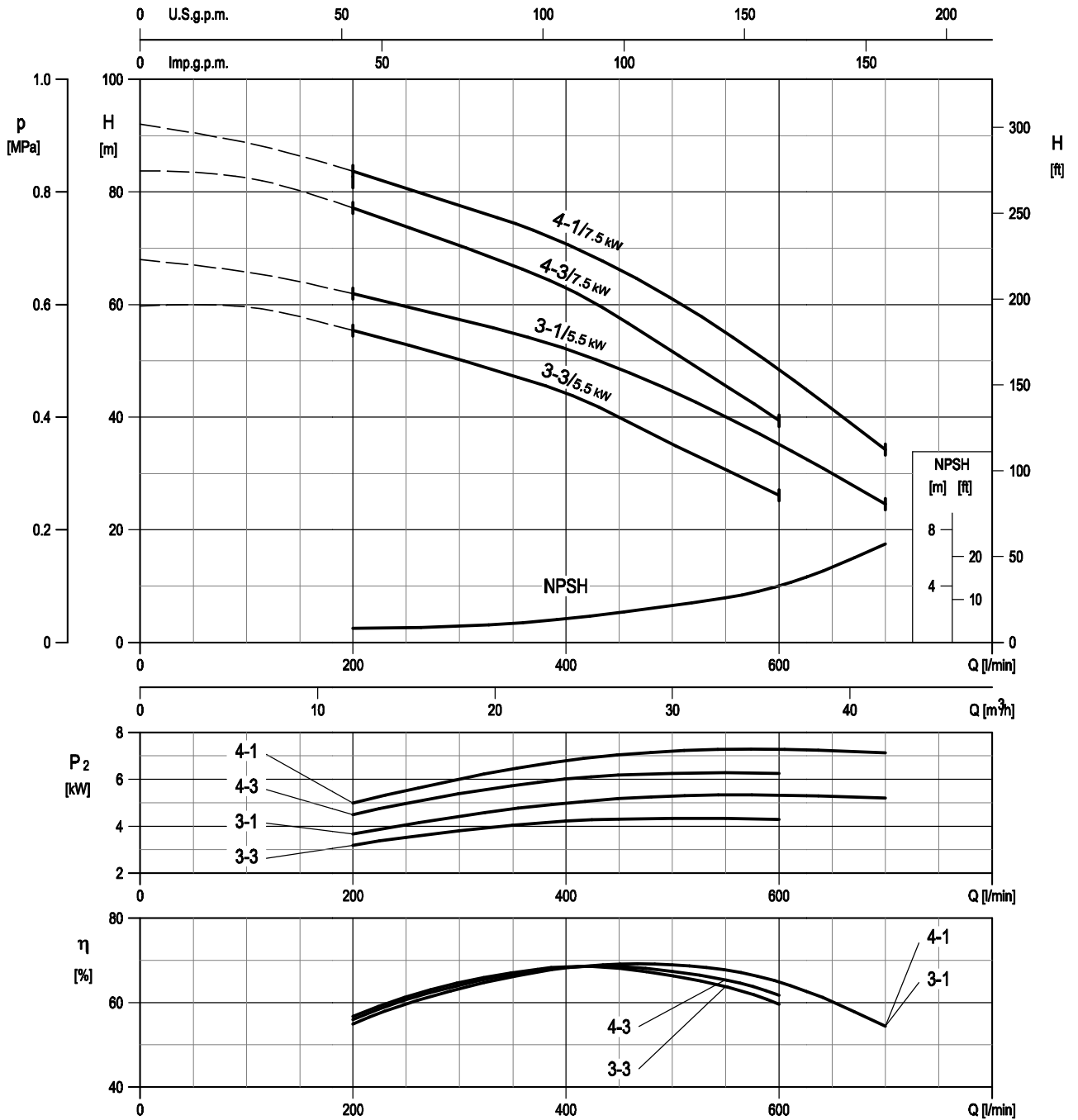

Rotation speed $\approx 2900 \text{ min}^{-1}$
Test standard: ISO 9906:2012 - Grade 3B

PERFORMANCE CURVE EVM(L)32

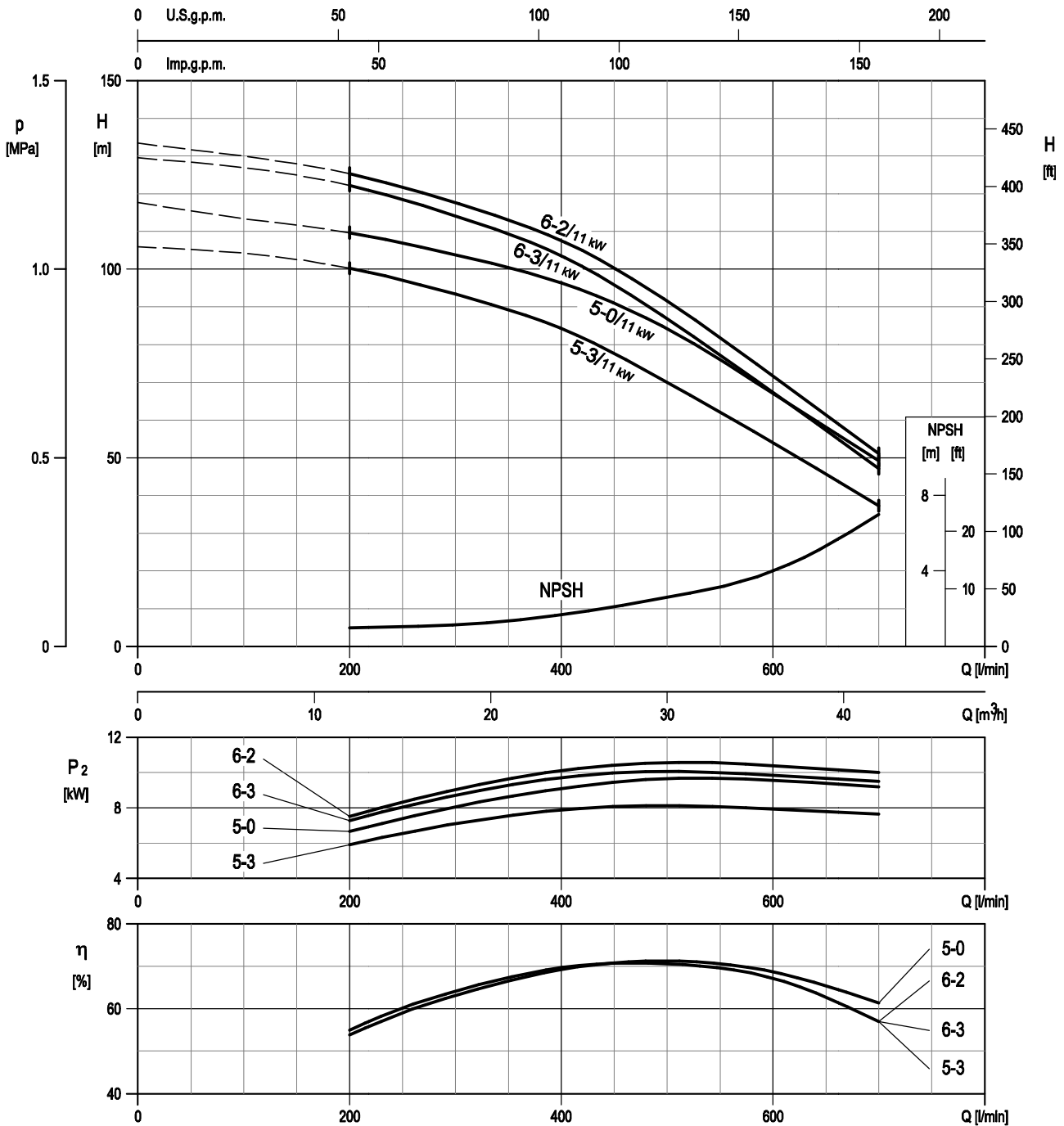

Rotation speed $\approx 2900 \text{ min}^{-1}$
 Test standard: ISO 9906:2012 - Grade 3B

PERFORMANCE CURVE
EVM(L)32

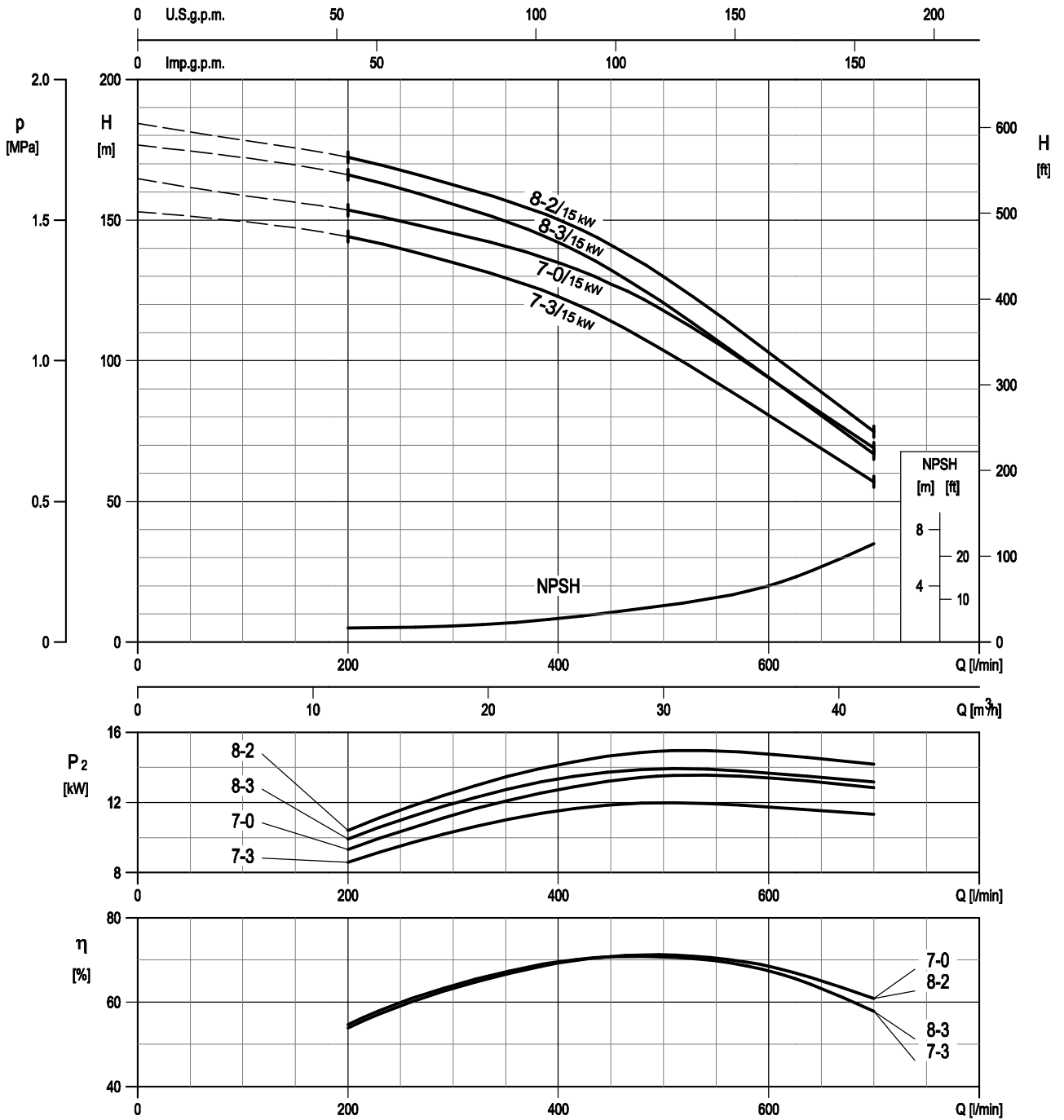

Rotation speed $\approx 2900 \text{ min}^{-1}$
Test standard: ISO 9906:2012 - Grade 3B

PERFORMANCE CURVE EVM(L)32

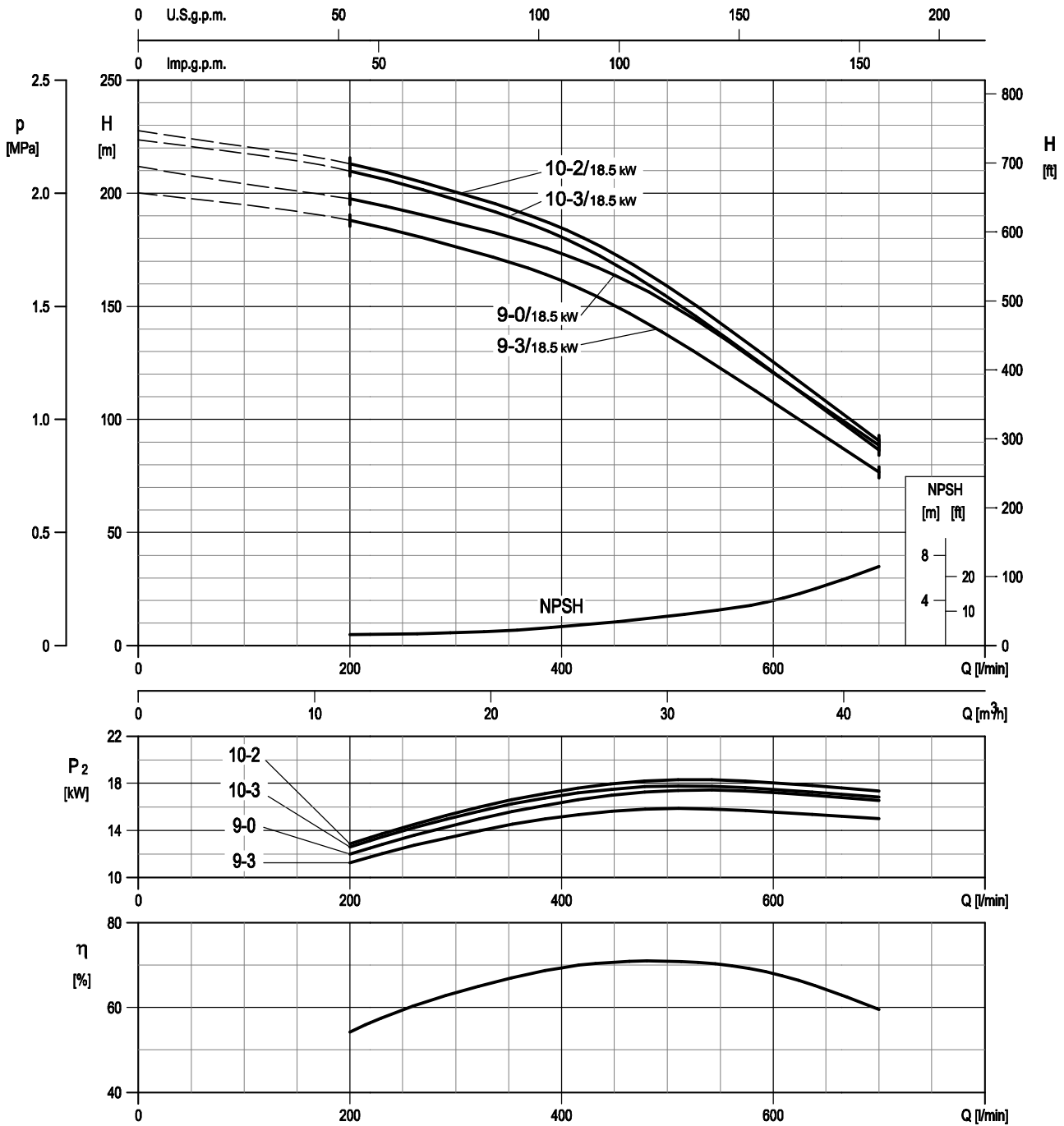

Rotation speed $\approx 2900 \text{ min}^{-1}$
 Test standard: ISO 9906:2012 - Grade 3B

EVM(L)32

PERFORMANCE CURVE
EVM(L)32

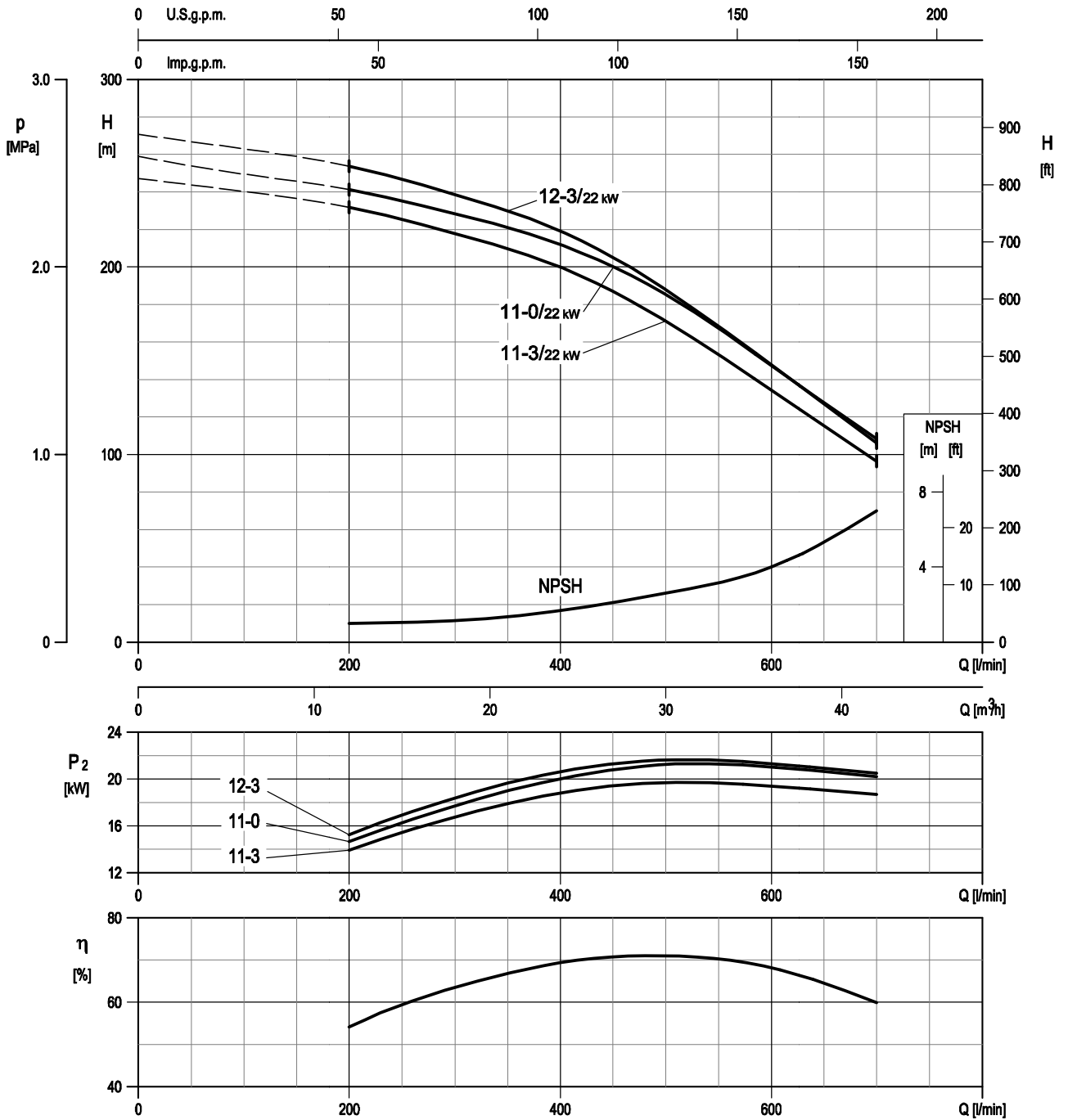

Rotation speed $\approx 2900 \text{ min}^{-1}$
Test standard: ISO 9906:2012 - Grade 3B

PERFORMANCE CURVE EVM(L)32

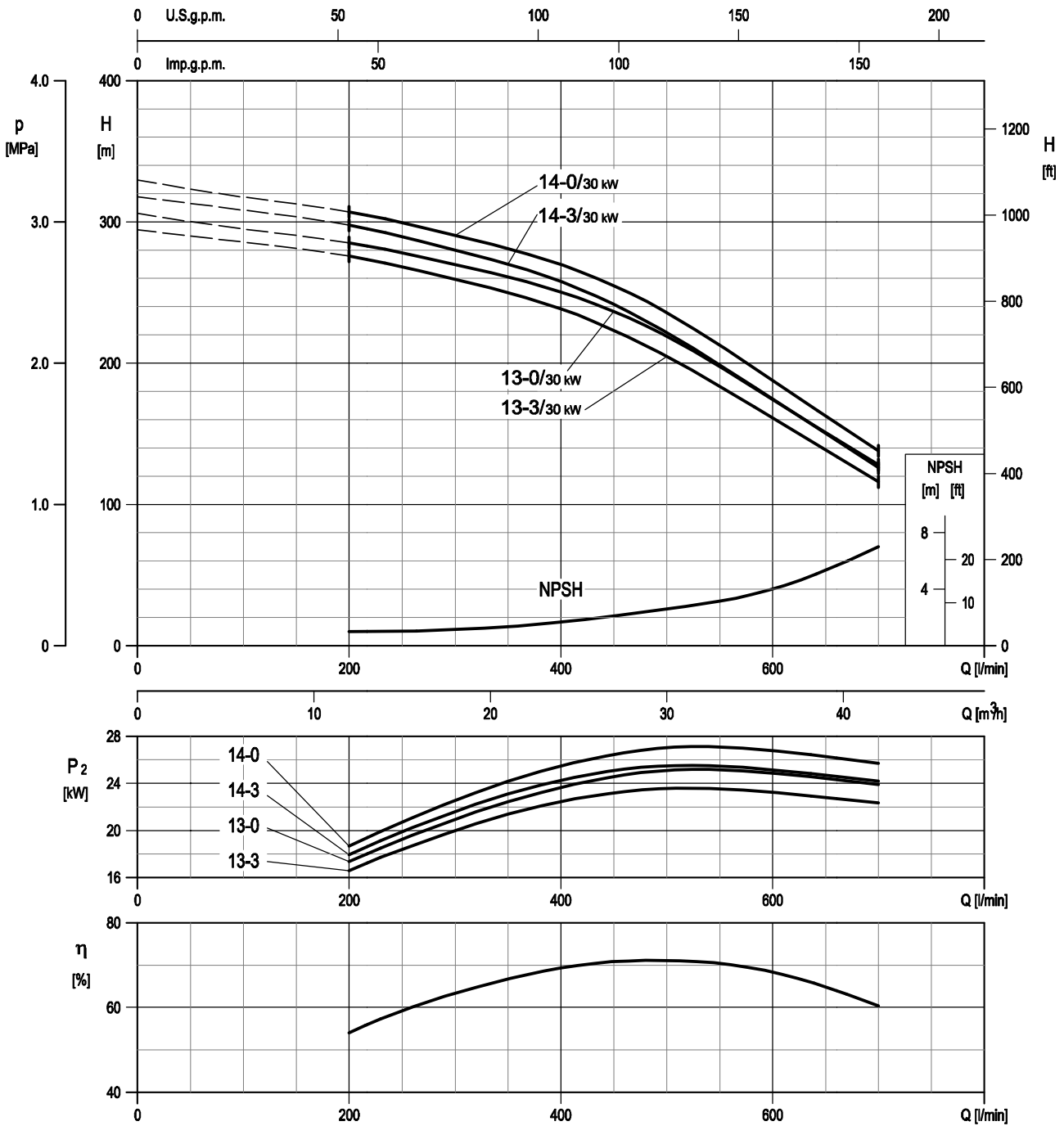

Rotation speed $\approx 2900 \text{ min}^{-1}$
 Test standard: ISO 9906:2012 - Grade 3B

EVM(L)32

TECHNICAL DATA
EVM(L)32

Dimensional sketch

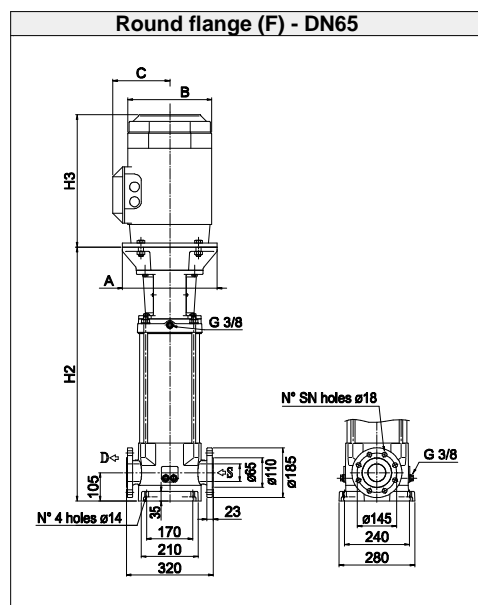

Dimensions [mm] and Weights [Kg]

Pump Type	P _{max} [MPa]	kW	Motor				Round flange (F)				
			Size	A	3 -			H2	SN	Weight Pump	Weight Pump + Motor
					B	C	H3				
EVM(L)32 1-0F5/2.2	1.6	2.2	90 L	140	180	148	267	493	4	56	72
EVM(L)32 2-2F5/3.0	1.6	3.0	100 L	160	196	155	306	503	4	58	80.8
EVM(L)32 2-0F5/4.0	1.6	4.0	112 M	160	196	155	306	503	4	58	80.8
EVM(L)32 3-3F5/5.5	1.6	5.5	132 S	300	225	160	328	572	4	74	112.6
EVM(L)32 3-1F5/5.5	1.6	5.5	132 S	300	225	160	328	572	4	74	112.6
EVM(L)32 4-3F5/7.5	1.6	7.5	132 S	300	225	160	350	620	4	77	117.4
EVM(L)32 4-1F5/7.5	1.6	7.5	132 S	300	225	160	350	620	4	77	117.4
EVM(L)32 5-3F5/11	1.6	11	160 M	350	248	194	476	799	4	96	158.5
EVM(L)32 5-0F5/11	1.6	11	160 M	350	248	194	476	799	4	96	158.5
EVM(L)32 6-3F5/11	1.6	11	160 M	350	248	194	476	847	4	99	161.5
EVM(L)32 6-2F5/11	1.6	11	160 M	350	248	194	476	847	4	99	161.5
EVM(L)32 7-3F5/15	1.6	15	160 M	350	317	238	498	895	4	102	190.9
EVM(L)32 7-0F5/15	1.6	15	160 M	350	317	238	498	895	4	102	190.9
EVM(L)32 8-3F5/15	2.5	15	160 M	350	317	238	498	943	8	105	193.9
EVM(L)32 8-2F5/15	2.5	15	160 M	350	317	238	498	943	8	105	193.9
EVM(L)32 9-3F5/18.5	2.5	18.5	160 L	350	317	238	542	991	8	108	212
EVM(L)32 9-0F5/18.5	2.5	18.5	160 L	350	317	238	542	991	8	108	212
EVM(L)32 10-3F5/18.5	2.5	18.5	160 L	350	317	238	542	1039	8	112	216
EVM(L)32 10-2F5/18.5	2.5	18.5	160 L	350	317	238	542	1039	8	112	216
EVM(L)32 11-3F5/22	2.5	22	180 M	350	360	268	577	1087	8	116	279
EVM(L)32 11-0F5/22	2.5	22	180 M	350	360	268	577	1087	8	116	279
EVM(L)32 12-3F5/22	2.5	22	180 M	350	360	268	577	1135	8	119	282
EVM(L)32 13-3F5/30	3.0	30	200 L	400	399	300	658	1198	8	129	357
EVM(L)32 13-0F5/30	3.0	30	200 L	400	399	300	658	1198	8	129	357
EVM(L)32 14-3F5/30	3.0	30	200 L	400	399	300	658	1246	8	133	361
EVM(L)32 14-0F5/30	3.0	30	200 L	400	399	300	658	1246	8	133	361

1.6 MPa=16 bar ; 2.5 MPa=25 bar; 3.0 MPa=30 bar

SECTIONAL VIEW EVM(L)32

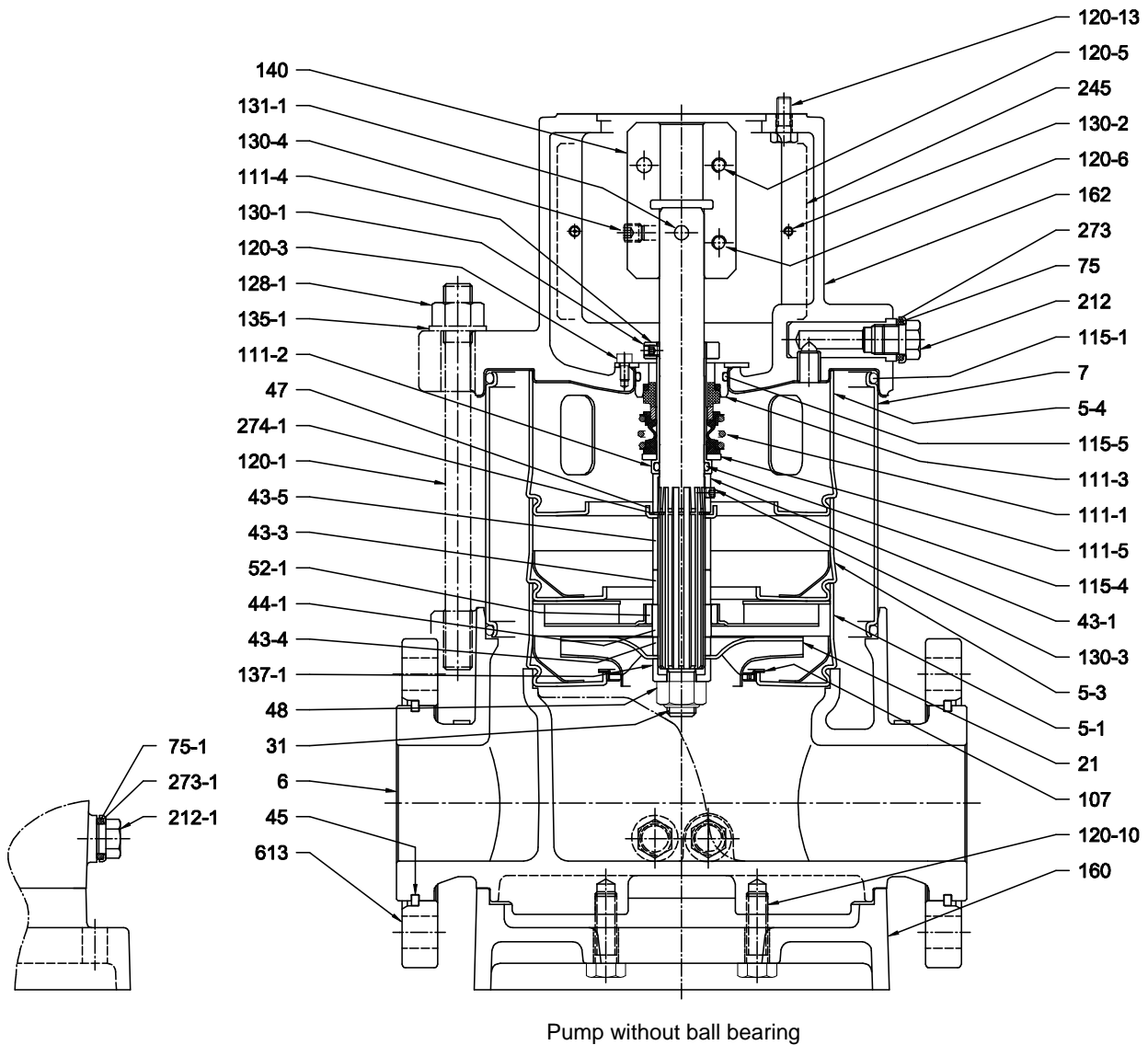

EVM(L)32

SECTIONAL VIEW
EVM(L)32

EVM(L)32

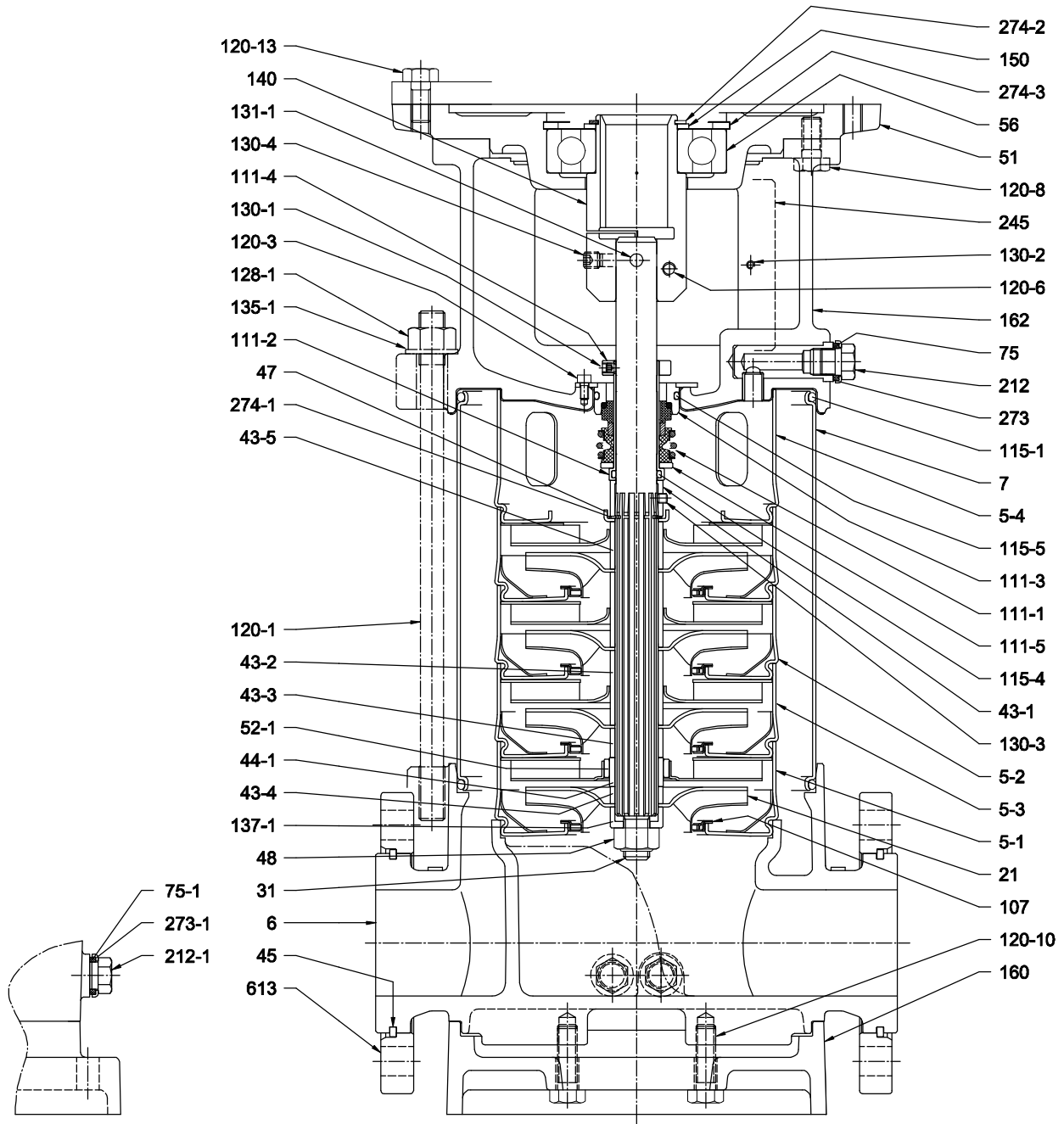

Pump with single ball bearing

SECTIONAL VIEW EVM(L)32

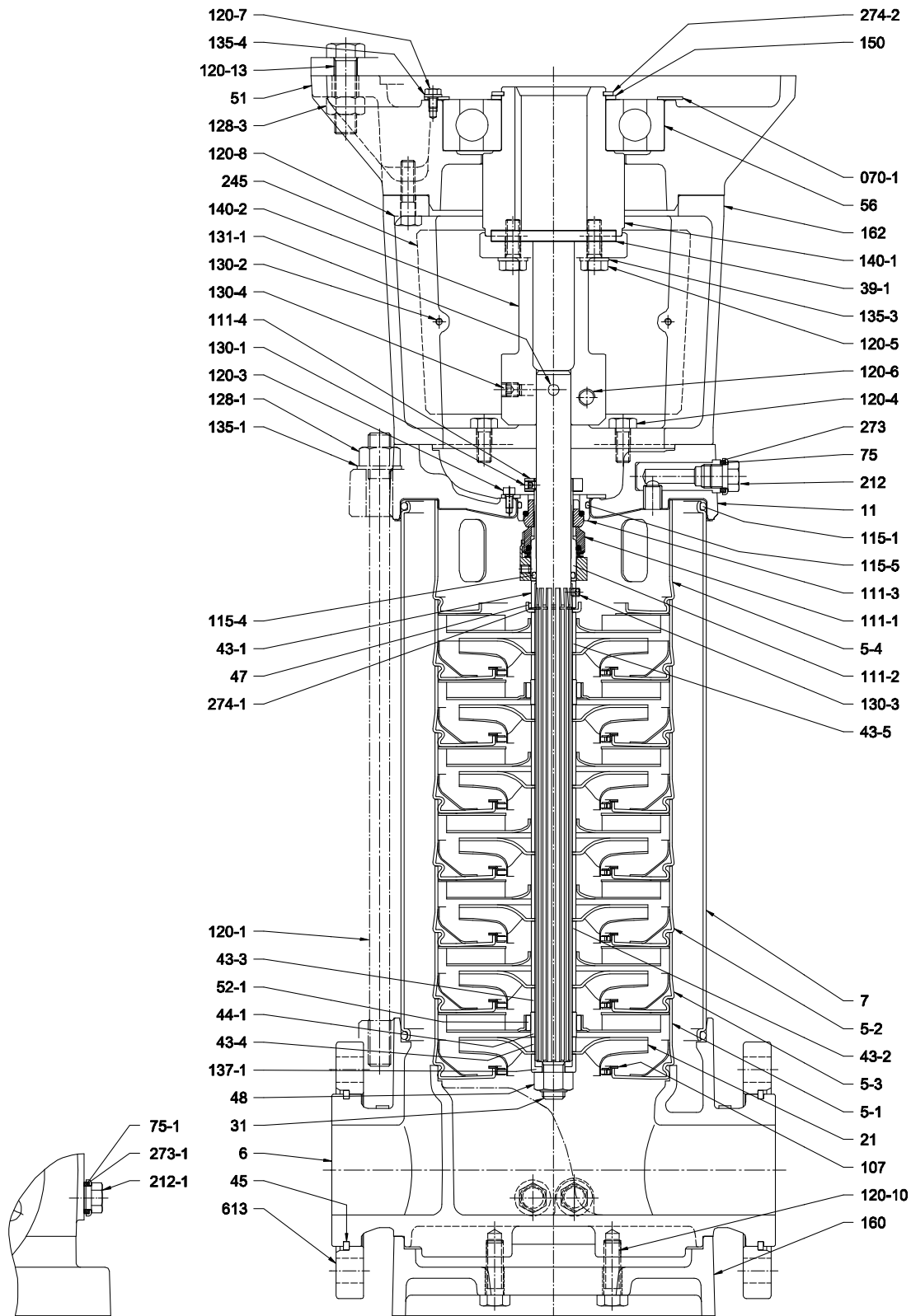

Pump with single ball bearing

EVM(L)32

SECTIONAL VIEW
EVM(L)32

EVM(L)32

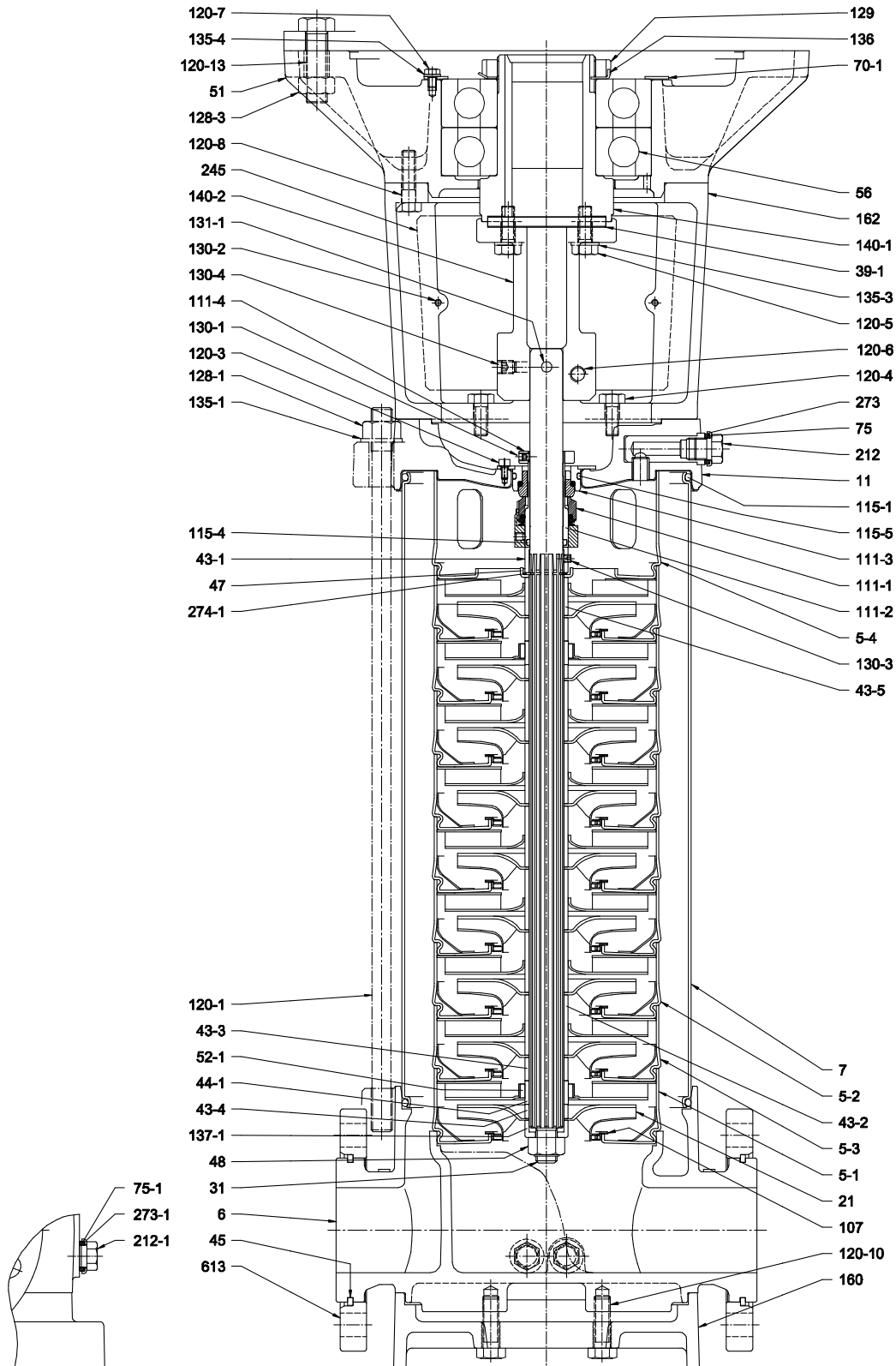

Pump with double ball bearing

SECTIONAL TABLE EVM(L)32

N°	PART NAME	MATERIAL		DIMENSIONS	STANDARD
		EVM	EVML		
5-1	Suction casing	EN 1.4301 (AISI 304)	EN 1.4401 (AISI 316)		
5-2	Intermediate Casing	EN 1.4301 (AISI 304)	EN 1.4401 (AISI 316)		
5-3	Intermediate casing bearing	EN 1.4301 (AISI 304)	EN 1.4401 (AISI 316)		
5-4	Discharge casing	EN 1.4301 (AISI 304)	EN 1.4401 (AISI 316)		
6	Bottom casing	EN 1.4308 (ASTM CF8)	EN 1.4408 (ASTM CF8M)		
7	Outer casing	EN 1.4301 (AISI 304)	EN 1.4401 (AISI 316)		
11	Casing cover	Cast iron+ EN 1.4301 (AISI 304)	Cast iron + EN 1.4401 (AISI 316)		
21	Impeller	EN 1.4301 (AISI 304)	EN 1.4401 (AISI 316)		
21-1	Reduced impeller				
31	Shaft	EN 1.4401 (AISI 316)			
39-1	Key	Carbon Steel		12x8x90	UNI 6604
43-1	Shaft sleeve (mechanical seal)	EN 1.4301 (AISI 304)	EN 1.4401 (AISI 316)		
43-2	Shaft sleeve (intermediate)	EN 1.4301 (AISI 304)	EN 1.4401 (AISI 316)		
43-3	Shaft sleeve (bearing)	EN 1.4301 (AISI 304)	EN 1.4401 (AISI 316)		
43-4	Shaft sleeve (adjustment)	EN 1.4301 (AISI 304)	EN 1.4401 (AISI 316)		
43-5	Shaft sleeve (last stage)	EN 1.4301 (AISI 304)	EN 1.4401 (AISI 316)		
44-1	Shaft sleeve bearing	Tungsten carbide			
45	Flange holder	EN 1.402 (AISI 420)			
47	Ring Holder	EN 1.4301 (AISI 304)	EN 1.4401 (AISI 316)		
48	Impeller nut	A2-70 UNI 7323 with inox insert	A4-70 UNI 7323 with inox insert	M16	
51	Motor adapter	Cast iron EN-GJL-200-EN 1561			
52-1	Bearing	Tungsten carbide			
56	Ball bearing	see table page 322			
70-1	Ring for bearing	EN 1.4301 (AISI 304)			
75	O-Ring (plug)	EPDM	FPM		
75-1	O-Ring (plug)	EPDM	FPM		
107	Liner ring	PTFE / EN 1.4301 (AISI 304)	PTFE / EN 1.4401 (AISI 316)		
111-1	Mechanical seal	Silicon carbide / Carbon / FPM			
111-2	Mechanical seal cartridge	EN 1.4301 (AISI 304)	EN 1.4401 (AISI 316)		
111-3	Mechanical seal seat	EN 1.4301 (AISI 304)	EN 1.4401 (AISI 316)		
111-4	Seal holder	Brass OT 58 UNI 5705	EN 1.4401 (AISI 316)		
111-5	Adjusting ring	EN 1.4301 (AISI 304)	EN 1.4401 (AISI 316)		
115-1	O-Ring (outer casing)	EPDM	FPM	D.208.91x5.34	
115-4	O-Ring (cartridge sleeve)	EPDM	FPM	D. 24,99x3,59	
115-5	O-Ring (seal cover)	EPDM	FPM	D.44.04x3.53	
120-1	Tie-rod	Galvanized steel 6.8 strenght class ISO 898/1			

SECTIONAL TABLE
EVM(L)32

N°	PART NAME	MATERIAL		DIMENSIONS	STANDARD
		EVM	EVML		
120-3	Screw	A2-70 UNI 7323		M5xX10	UNI 5931
120-4	Screw	Galvanized steel 8.8 strenght class ISO 898/1		M10x25	UNI 5739
120-5	Screw for coupling	EVM32 1	Galvanized steel 8.8 strenght class ISO 898/1	M6x16	UNI 5931
		EVM32 2 and 2-2		M8x20	UNI 5931
		EVM32 5 to 14		M10x30	UNI 5739
120-6	Screw for coupling	EVM32 1	Galvanized steel 8.8 strenght class ISO 898/1	M6x16	UNI 5931
		EVM32 2 to 4-3		M8x20	UNI 5931
		EVM32 5 to 14		M12x30	UNI 5931
120-7	Screw	Galvanized steel 8.8 strenght class ISO 898/1		M6x10	UNI 5739
120-8	Screw	EVM32 3 to 4	Galvanized steel 8.8 strenght class ISO 898/1	M12x25	UNI 5739
		EVM32 5 to 14		M10x30	UNI 5739
120-10	Screw	Galvanized steel 8.8 strenght class ISO 898/1		M12x40	UNI 5739
120-13	Screw for motor	EVM32 1 to 2	Galvanized steel 8.8 strenght class ISO 898/1	M8x20	UNI 5739
		EVM32 3 to 4		M12x30	UNI 5739
		EVM32 5 to 14		M16x65	UNI 5739
128-1	Nut for tie rod	Galvanized steel		M16	UNI 5588
128-3	Nut	Galvanized steel		M16	UNI 5588
129	Lock nut	Carbon Steel			
130-1	Set screw	A2-70 UNI 7323		M6x8	UNI 5923
130-2	Screw for coupling guard	A2-70 UNI 7323		M5x6	UNI 7687
130-3	Set screw	A2-70 UNI 7323		M6x6	UNI 5923
130-4	Set screw	Carbon steel		M10x10	UNI 5923
131-1	Pin for shaft	Carbon Steel			
135-1	Washer	Galvanized steel		17x30x3	UNI 6592
135-3	Washer	Galvanized steel		10.5x17.5x2.2	UNI 1751
135-4	Washer	Plated carbon steel		06:04	UNI 1751
136	Washer	Carbon steel			
137-1	Impeller spacer	EN 1.4301 (AISI 304)	EN 1.4401 (AISI 316)		
140	Coupling	Brass OT 58 UNI 5705			
140-1	Motor coupling	Carbon steel			
140-2	Coupling (motor side)	Carbon steel			
150	Spacer	Carbon steel			
160	Base	Cast iron EN-GJL-200-EN 1561			
162	Motor bracket	Cast iron EN-GJL-200-EN 1561			
212	Plug	EN 1.4301 (AISI 304)	EN 1.4401 (AISI 316)		
212-1	Plug	EN 1.4301 (AISI 304)	EN 1.4401 (AISI 316)		
245	Coupling guard	EN 1.4301 (AISI 304)			
273	Plug Washer	EN 1.4301 (AISI 304)	EN 1.4401 (AISI 316)		
273-1	Plug Washer	EN 1.4301 (AISI 304)	EN 1.4401 (AISI 316)		
274-1	C-type snap ring (mechanical seal)	EN 1.4301 (AISI 304)	EN 1.4401 (AISI 316)	D.26	UNI 7435
274-2	C-type snap ring (coupling)	EVM32 3 to 4	Carbon Steel TC 80	D.50	UNI 7435
		EVM32 5 to 10		D.65	UNI 7435
		EVM32 11 to 12		D.75	UNI 7535
274-3	C-type snap ring (bracket)	Carbon Steel TC 80		D.110	UNI 7437
613	Flange	Carbon steel			

QUANTITY FOR MODEL EVM(L)32

Pump Type	N°																														
	5-2	5-3	11	21	21-1	39-1	43-2	43-3	43-4	44-1	51	52-1	56	70-1	107	111-5	120-4	120-5	120-7	120-8	128-3	129	135-3	135-4	136	140	140-1	140-2	150	274-2	274-3
EVM(L)32 1-0F5/2.2	/	1	/	1	/	/	/	1	1	1	/	1	/	/	1	1	/	2	/	/	/	/	/	/	/	1	/	/	/	/	/
EVM(L)32 2-2F5/3.0	/	1	/	/	2	/	/	1	1	1	/	1	/	/	2	1	/	2	/	/	/	/	/	/	/	1	/	/	/	/	/
EVM(L)32 2-0F5/4.0	/	1	/	2	/	/	/	1	1	1	/	1	/	/	2	1	/	2	/	/	/	/	/	/	/	1	/	/	/	/	/
EVM(L)32 3-3F5/5.5	1	1	/	3	/	1	1	1	1	1	1	1	1	3	1	/	/	/	/	4	/	/	/	/	/	1	/	/	1	1	1
EVM(L)32 3-1F5/5.5	1	1	/	2	1	/	1	1	1	1	1	1	1	/	3	1	/	/	/	4	/	/	/	/	/	1	/	/	1	1	1
EVM(L)32 4-3F5/7.5	2	1	/	1	3	/	2	1	1	1	1	1	1	/	4	1	/	/	/	4	/	/	/	/	/	1	/	/	1	1	1
EVM(L)32 4-1F5/7.5	2	1	/	3	1	/	2	1	1	1	1	1	1	/	4	1	/	/	4	/	/	/	/	/	1	/	/	1	1	1	
EVM(L)32 5-3F5/11	3	1	1	2	3	1	3	1	1	1	1	1	1	1	5	1	4	4	3	4	4	/	4	3	/	/	1	1	1	1	/
EVM(L)32 5-0F5/11	3	1	1	5	/	1	3	1	1	1	1	1	1	1	5	1	4	4	3	4	4	/	4	3	/	/	1	1	1	1	/
EVM(L)32 6-3F5/11	4	1	1	3	3	1	4	1	1	1	1	1	1	1	6	1	4	4	3	4	4	/	4	3	/	/	1	1	1	1	/
EVM(L)32 6-2F5/11	4	1	1	4	2	1	4	1	1	1	1	1	1	1	6	1	4	4	3	4	4	/	4	3	/	/	1	1	1	1	/
EVM(L)32 7-3F5/15	5	1	1	4	3	1	5	1	1	1	1	1	1	1	7	1	4	4	3	4	4	/	4	3	/	/	1	1	1	1	/
EVM(L)32 7-0F5/15	5	1	1	7	/	1	5	1	1	1	1	1	1	1	7	1	4	4	3	4	4	/	4	3	/	/	1	1	1	1	/
EVM(L)32 8-3F5/15	6	1	1	5	3	1	6	1	1	1	1	1	1	1	8	1	4	4	3	4	4	/	4	3	/	/	1	1	1	1	/
EVM(L)32 8-2F5/15	6	1	1	6	2	1	6	1	1	1	1	1	1	1	8	1	4	4	3	4	4	/	4	3	/	/	1	1	1	1	/
EVM(L)32 9-3F5/18.5	7	1	1	6	3	1	7	1	1	1	1	1	1	1	9	1	4	4	3	4	4	/	4	3	/	/	1	1	1	1	/
EVM(L)32 9-0F5/18.5	7	1	1	9	/	1	7	1	1	1	1	1	1	1	9	1	4	4	3	4	4	/	4	3	/	/	1	1	1	1	/
EVM(L)32 10-3F5/18.5	7	2	1	7	3	1	7	2	2	2	2	1	2	1	10	1	4	4	3	4	4	/	4	3	/	/	1	1	1	1	/
EVM(L)32 10-2F5/18.5	7	2	1	8	2	1	7	2	2	2	2	1	2	1	10	1	4	4	3	4	4	/	4	3	/	/	1	1	1	1	/
EVM(L)32 11-3F5/22	8	2	1	8	3	1	8	2	2	2	2	1	2	1	11	1	4	4	3	4	4	/	4	3	/	/	1	1	1	1	/
EVM(L)32 11-0F5/22	8	2	1	11	/	1	8	2	2	2	2	1	2	1	11	1	4	4	3	4	4	/	4	3	/	/	1	1	1	1	/
EVM(L)32 12-3F5/22	9	2	1	9	3	1	9	2	2	2	2	1	2	1	12	1	4	4	3	4	4	/	4	3	/	/	1	1	1	1	/
EVM(L)32 13-3F5/30	10	2	1	10	3	1	10	2	2	2	2	1	2	1	13	/	4	4	3	4	4	1	4	3	1	/	1	1	1	1	/
EVM(L)32 13-0F5/30	10	2	1	13	/	1	10	2	2	2	2	1	2	1	13	/	4	4	3	4	4	1	4	3	1	/	1	1	1	1	/
EVM(L)32 14-3F5/30	11	2	1	11	3	1	11	2	2	2	2	1	2	1	14	/	4	4	3	4	4	1	4	3	1	/	1	1	1	1	/
EVM(L)32 14-0F5/30	11	2	1	14	/	1	11	2	2	2	2	1	2	1	14	/	4	4	3	4	4	1	4	3	1	/	1	1	1	1	/

BEARINGS EVM(L)32

Pump Type	N°
EVM(L)32 1-0F5/2.2	/
EVM(L)32 2-2F5/3.0	/
EVM(L)32 2-0F5/4.0	/
EVM(L)32 3-3F5/5.5	6310 ZZ C3
EVM(L)32 3-1F5/5.5	6310 ZZ C3
EVM(L)32 4-3F5/7.5	6310 ZZ C3
EVM(L)32 4-1F5/7.5	6310 ZZ C3
EVM(L)32 5-3F5/11	6313 ZZ C3
EVM(L)32 5-0F5/11	6313 ZZ C3
EVM(L)32 6-3F5/11	6313 ZZ C3
EVM(L)32 6-2F5/11	6313 ZZ C3
EVM(L)32 7-3F5/15	6313 ZZ C3
EVM(L)32 7-0F5/15	6313 ZZ C3
EVM(L)32 8-3F5/15	6313 ZZ C3
EVM(L)32 8-2F5/15	6313 ZZ C3
EVM(L)32 9-3F5/18.5	6313 ZZ C3
EVM(L)32 9-0F5/18.5	6313 ZZ C3
EVM(L)32 10-3F5/18.5	6313 ZZ C3
EVM(L)32 10-2F5/18.5	6313 ZZ C3
EVM(L)32 11-3F5/22	6315 ZZ C3
EVM(L)32 11-0F5/22	6315 ZZ C3
EVM(L)32 12-3F5/22	6315 ZZ C3
EVM(L)32 13-3F5/30	6315 ZZDT C3 *
EVM(L)32 13-0F5/30	6315 ZZDT C3 *
EVM(L)32 14-3F5/30	6315 ZZDT C3 *
EVM(L)32 14-0F5/30	6315 ZZDT C3 *

*DT=Two single row deep groove ball bearings matched for paired mounting in a tandem arrangement.

PERFORMANCE CURVE
EVMG32

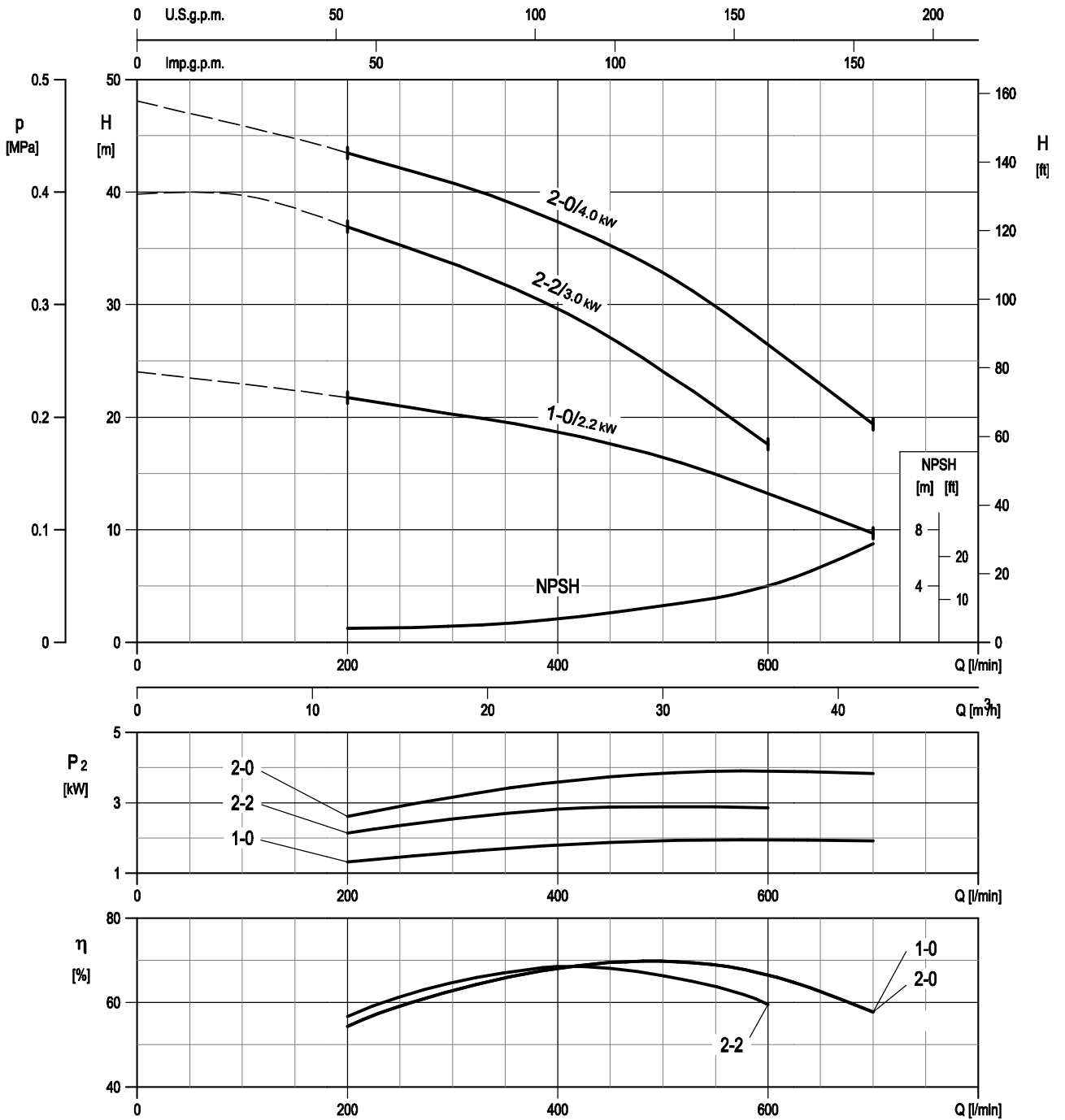

Rotation speed $\approx 2900 \text{ min}^{-1}$
 Test standard: ISO 9906:2012 - Grade 3B

PERFORMANCE CURVE EVMG32

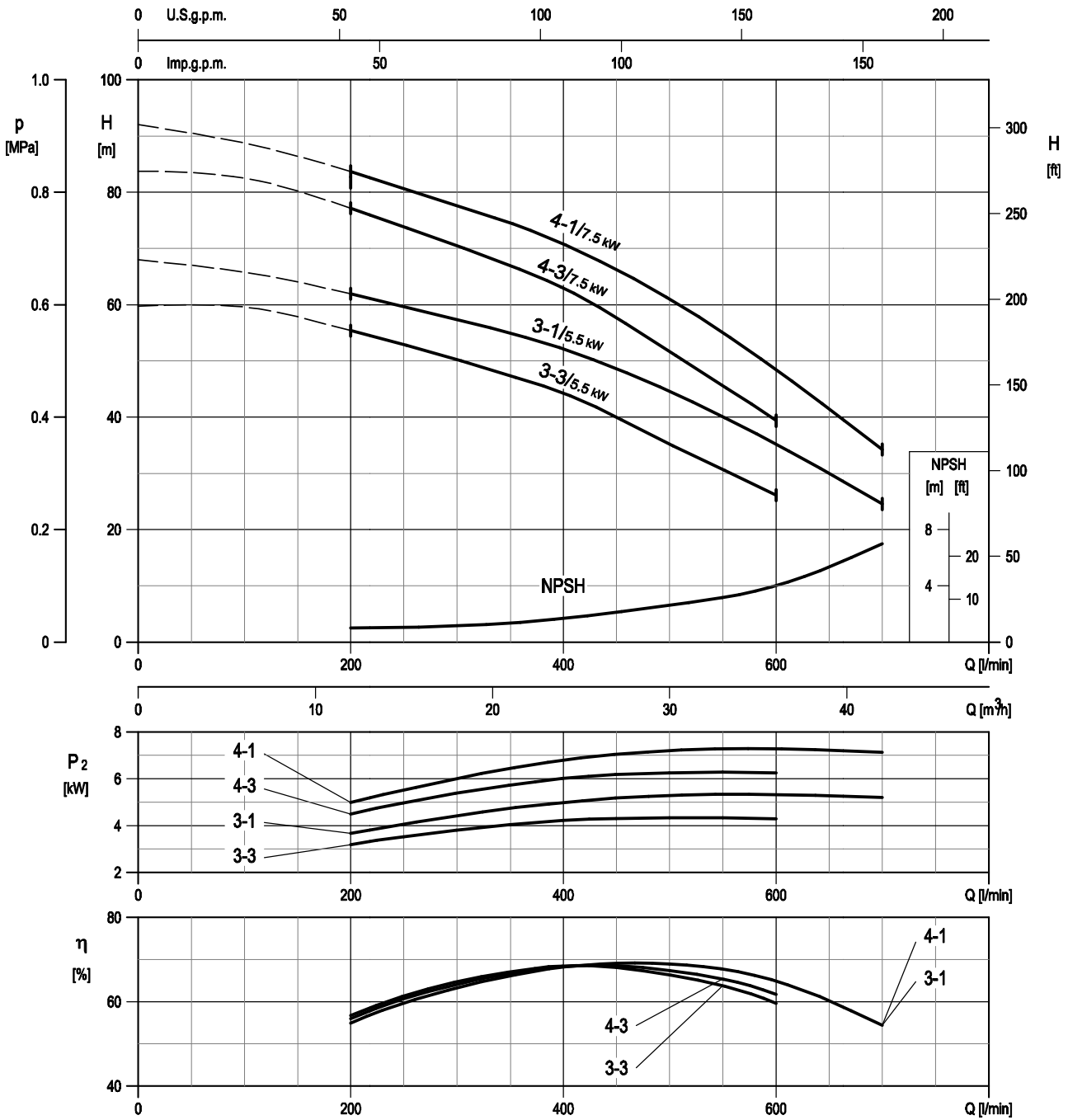

Rotation speed $\approx 2900 \text{ min}^{-1}$
 Test standard: ISO 9906:2012 - Grade 3B

PERFORMANCE CURVE
EVMG32

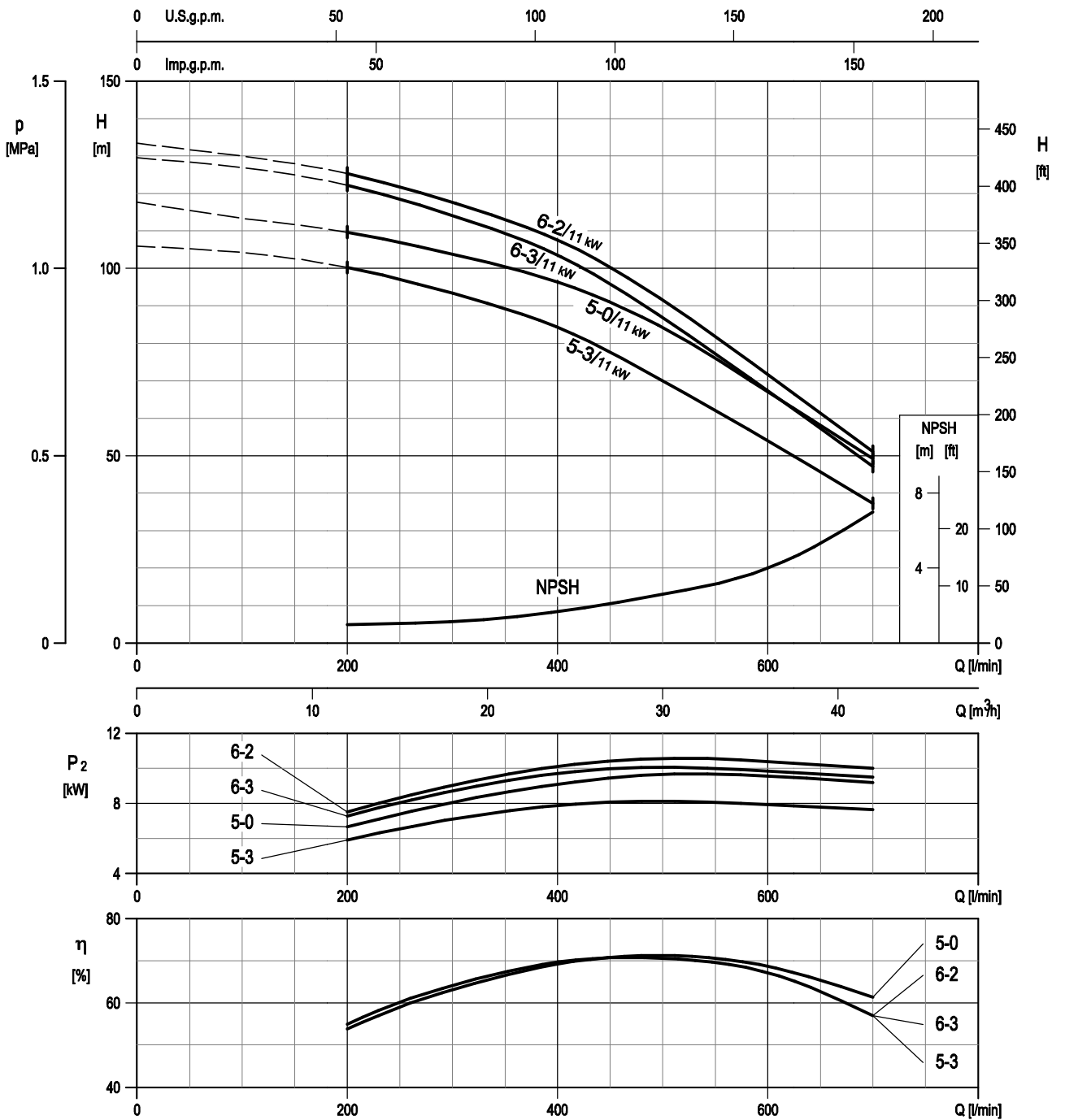

Rotation speed $\approx 2900 \text{ min}^{-1}$
 Test standard: ISO 9906:2012 - Grade 3B

PERFORMANCE CURVE EVMG32

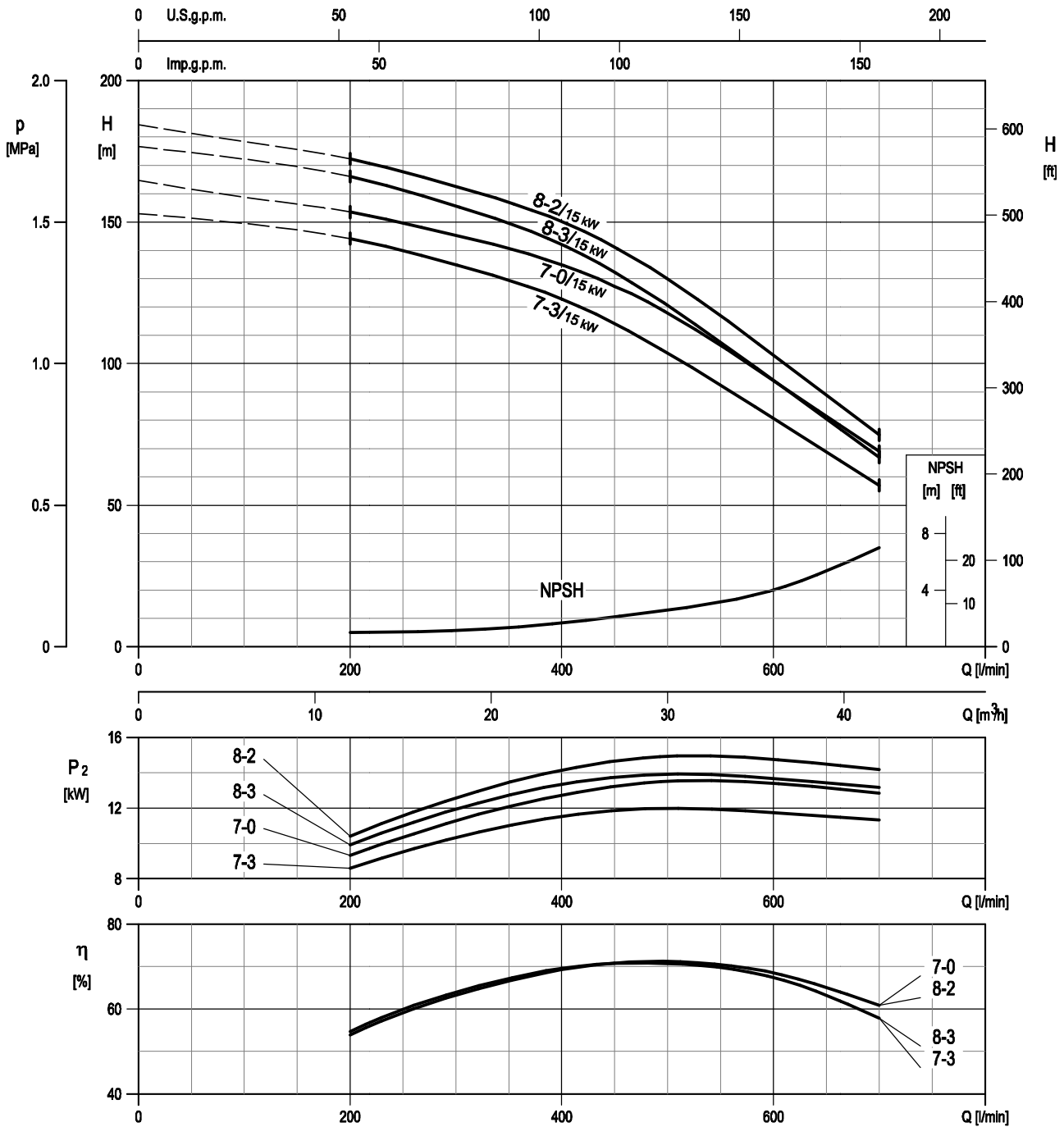

Rotation speed $\approx 2900 \text{ min}^{-1}$
 Test standard: ISO 9906:2012 - Grade 3B

PERFORMANCE CURVE
EVMG32

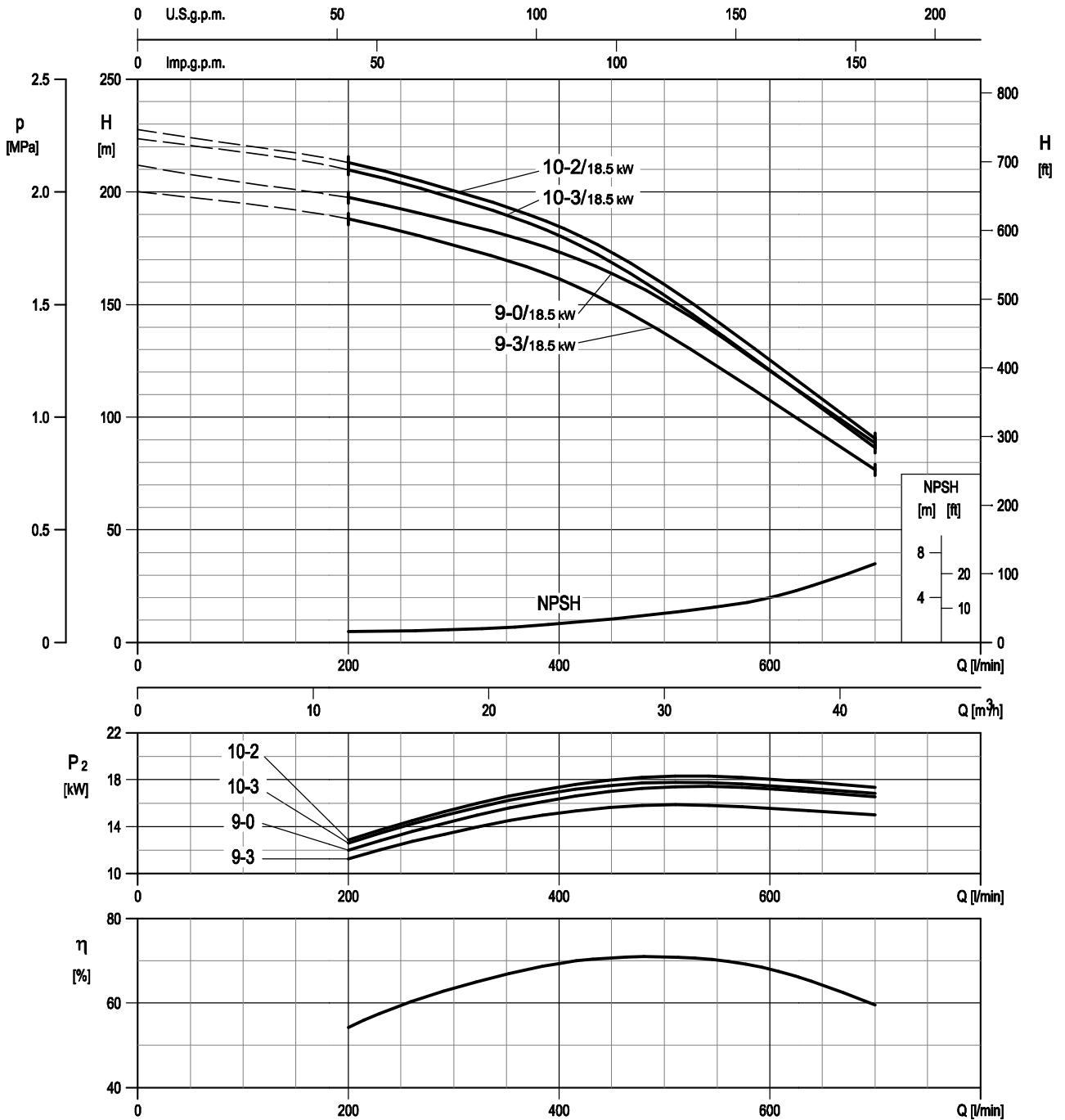

Rotation speed $\approx 2900 \text{ min}^{-1}$
Test standard: ISO 9906:2012 - Grade 3B

EVMG32

PERFORMANCE CURVE EVMG32

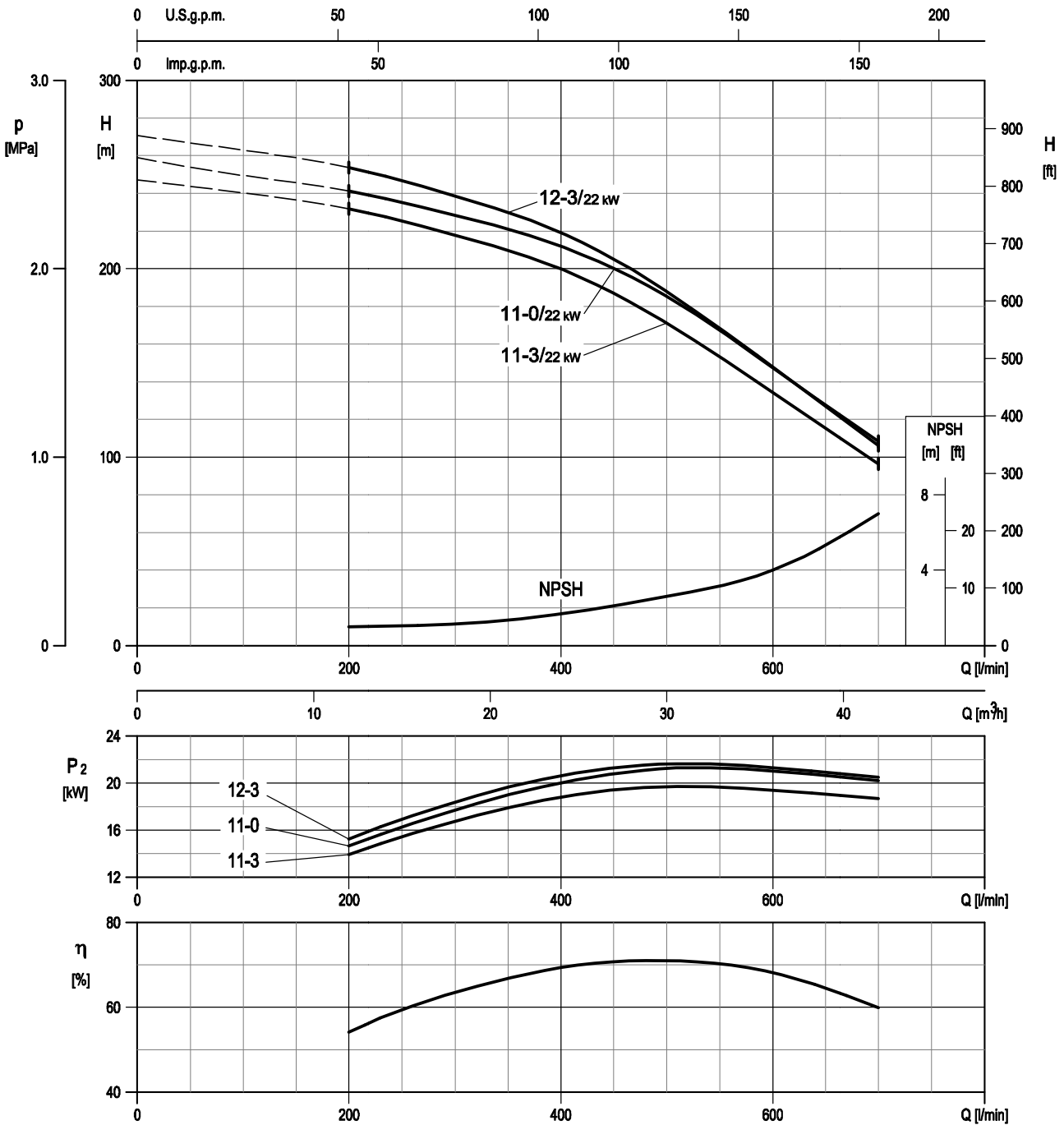

Rotation speed $\approx 2900 \text{ min}^{-1}$
 Test standard: ISO 9906:2012 - Grade 3B

EVMG32

PERFORMANCE CURVE
EVMG32

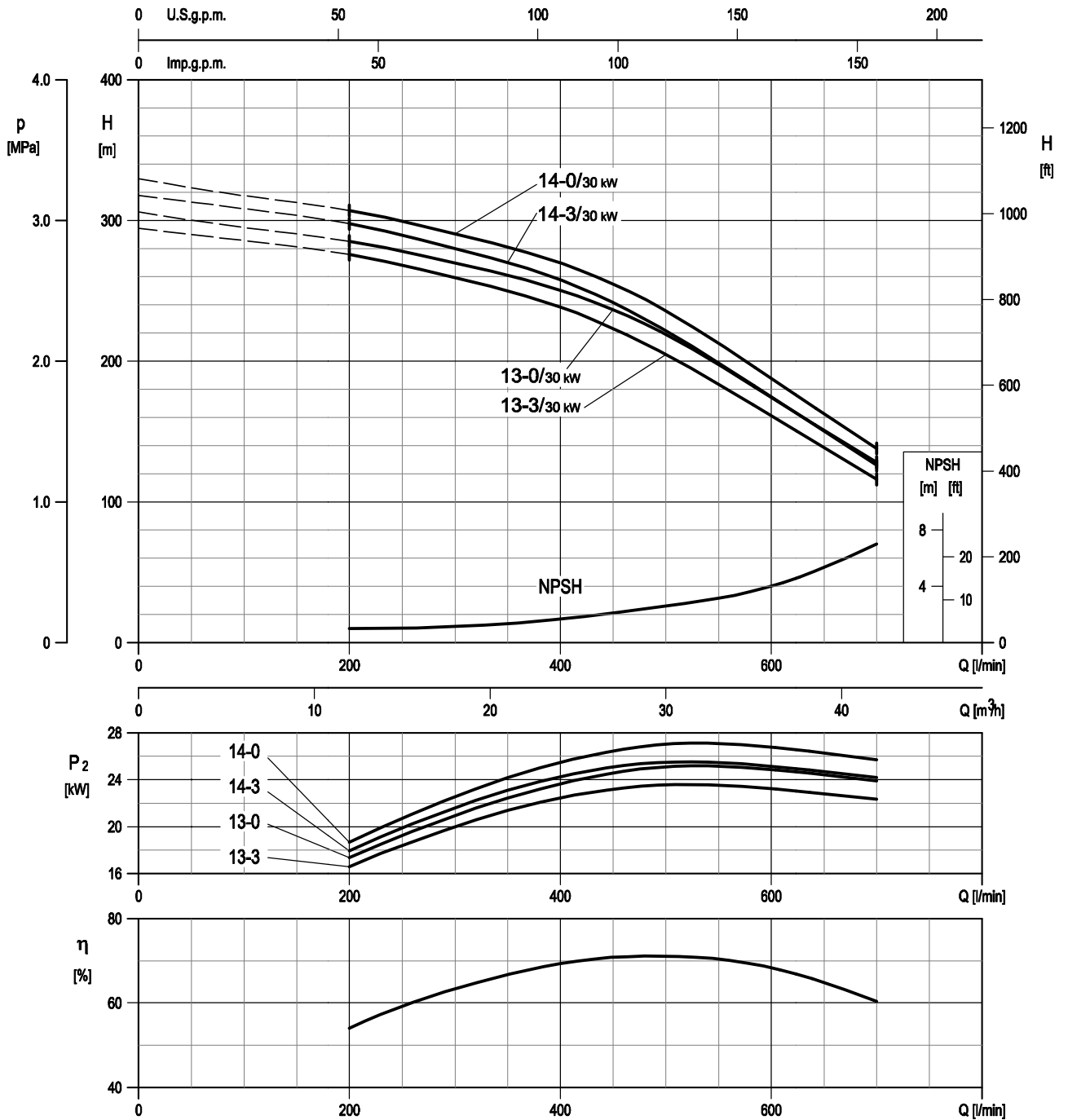

Rotation speed $\approx 2900 \text{ min}^{-1}$
Test standard: ISO 9906:2012 - Grade 3B

TECHNICAL DATA EVMG32

Dimensional sketch

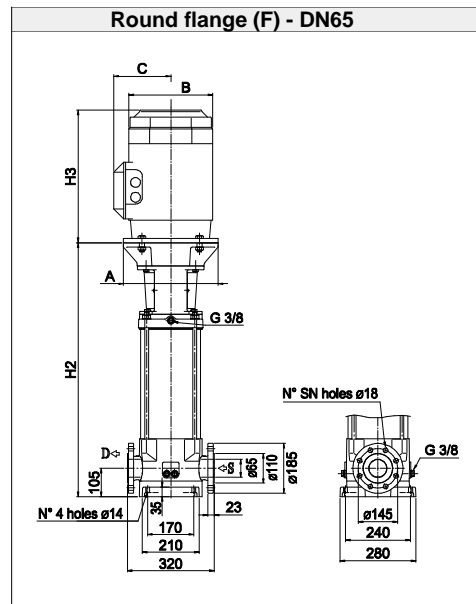

Dimensions [mm] and Weights [Kg]

Pump Type	P _{max} [MPa]	kW	Motor				Round flange (F)				
			Size	A	3 -			H2	SN	Weight Pump	Weight Pump + Motor
					B	C	H3				
EVMG32 1-0F5/2.2	1.6	2.2	90 L	140	180	148	267	493	4	56	72
EVMG32 2-2F5/3.0	1.6	3.0	100 L	160	196	155	306	503	4	58	80.8
EVMG32 2-0F5/4.0	1.6	4.0	112 M	160	196	155	306	503	4	58	80.8
EVMG32 3-3F5/5.5	1.6	5.5	132 S	300	225	160	328	572	4	74	112.6
EVMG32 3-1F5/5.5	1.6	5.5	132 S	300	225	160	328	572	4	74	112.6
EVMG32 4-3F5/7.5	1.6	7.5	132 S	300	225	160	350	620	4	77	117.4
EVMG32 4-1F5/7.5	1.6	7.5	132 S	300	225	160	350	620	4	77	117.4
EVMG32 5-3F5/11	1.6	11	160 M	350	248	194	476	799	4	96	158.5
EVMG32 5-0F5/11	1.6	11	160 M	350	248	194	476	799	4	96	158.5
EVMG32 6-3F5/11	1.6	11	160 M	350	248	194	476	847	4	99	161.5
EVMG32 6-2F5/11	1.6	11	160 M	350	248	194	476	847	4	99	161.5
EVMG32 7-3F5/15	1.6	15	160 M	350	317	238	498	895	4	102	190.9
EVMG32 7-0F5/15	1.6	15	160 M	350	317	238	498	895	4	102	190.9
EVMG32 8-3F5/15	2.5	15	160 M	350	317	238	498	943	8	105	193.9
EVMG32 8-2F5/15	2.5	15	160 M	350	317	238	498	943	8	105	193.9
EVMG32 9-3F5/18.5	2.5	18.5	160 L	350	317	238	542	991	8	108	212
EVMG32 9-0F5/18.5	2.5	18.5	160 L	350	317	238	542	991	8	108	212
EVMG32 10-3F5/18.5	2.5	18.5	160 L	350	317	238	542	1039	8	112	216
EVMG32 10-2F5/18.5	2.5	18.5	160 L	350	317	238	542	1039	8	112	216
EVMG32 11-3F5/22	2.5	22	180 M	350	360	268	577	1087	8	116	279
EVMG32 11-0F5/22	2.5	22	180 M	350	360	268	577	1087	8	116	279
EVMG32 12-3F5/22	2.5	22	180 M	350	360	268	577	1135	8	119	282
EVMG32 13-3F5/30	3.0	30	200 L	400	399	300	658	1198	8	129	357
EVMG32 13-0F5/30	3.0	30	200 L	400	399	300	658	1198	8	129	357
EVMG32 14-3F5/30	3.0	30	200 L	400	399	300	658	1246	8	133	361
EVMG32 14-0F5/30	3.0	30	200 L	400	399	300	658	1246	8	133	361

1.6 MPa=16 bar ; 2.5 MPa=25 bar ; 3.0 MPa=30 bar

SECTIONAL VIEW
EVMG32

EVMG32

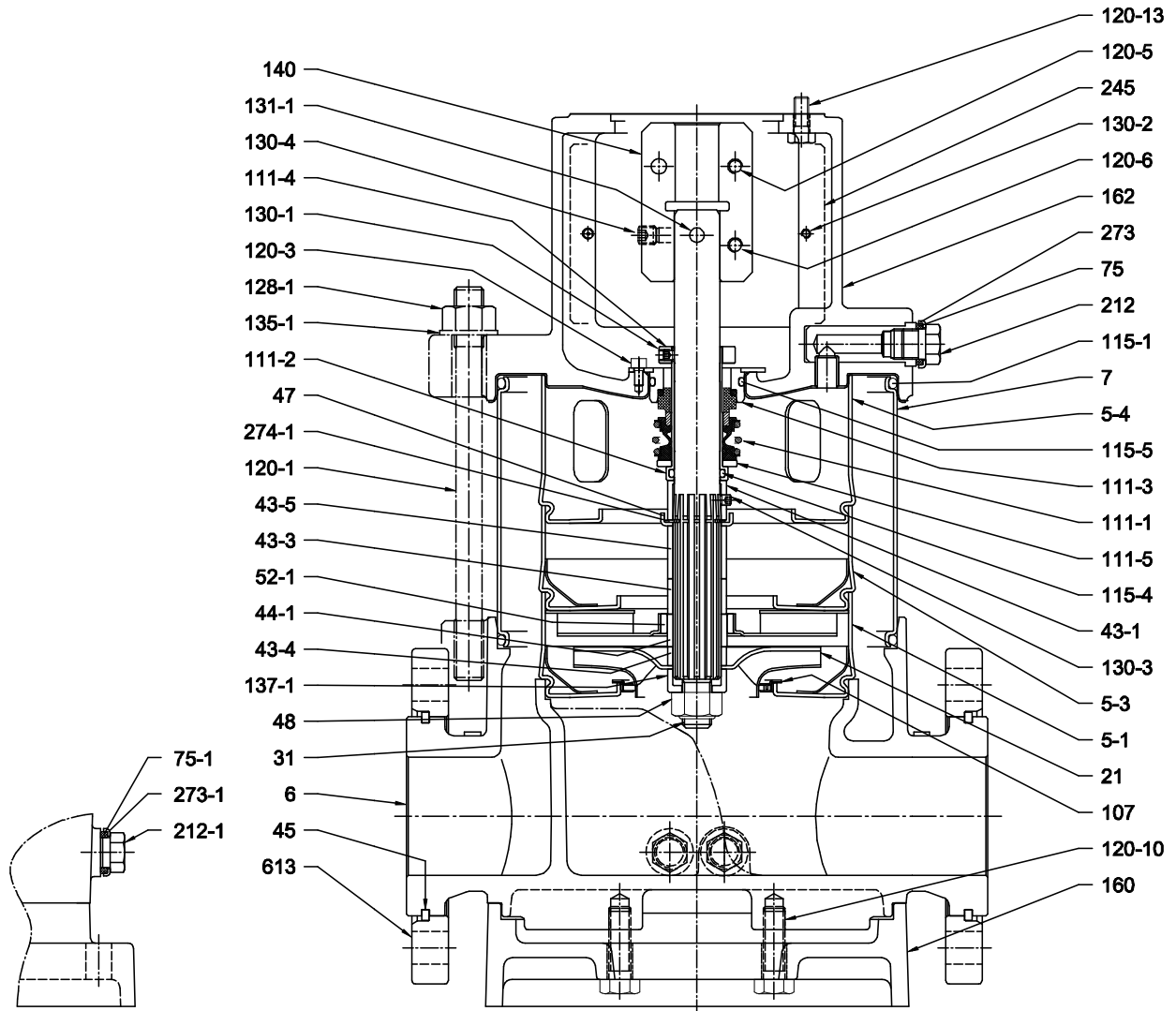

Pump without ball bearing

SECTIONAL VIEW EVMG32

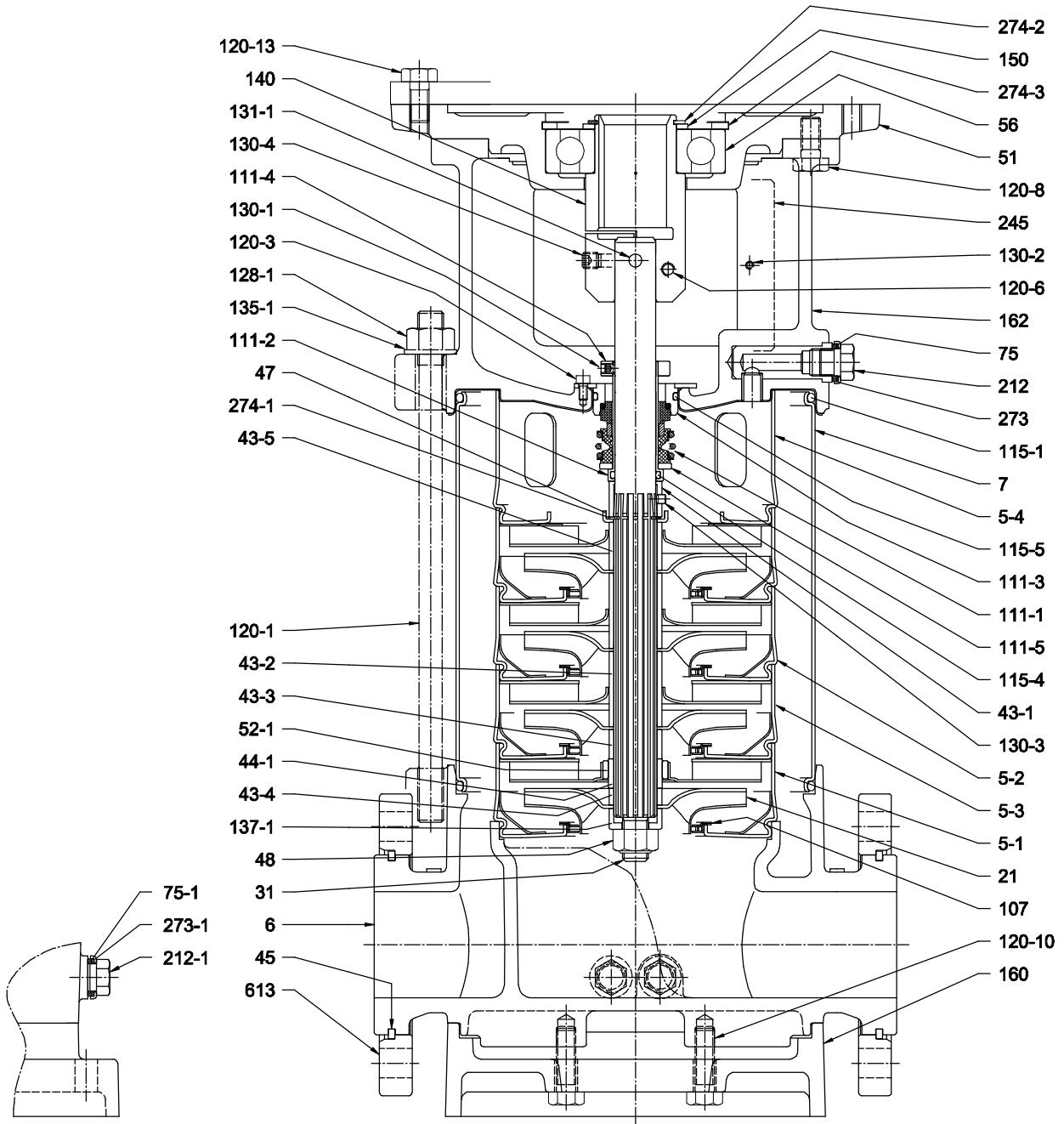

Pump with single ball bearing

EVMG32

SECTIONAL VIEW
EVMG32

EVMG32

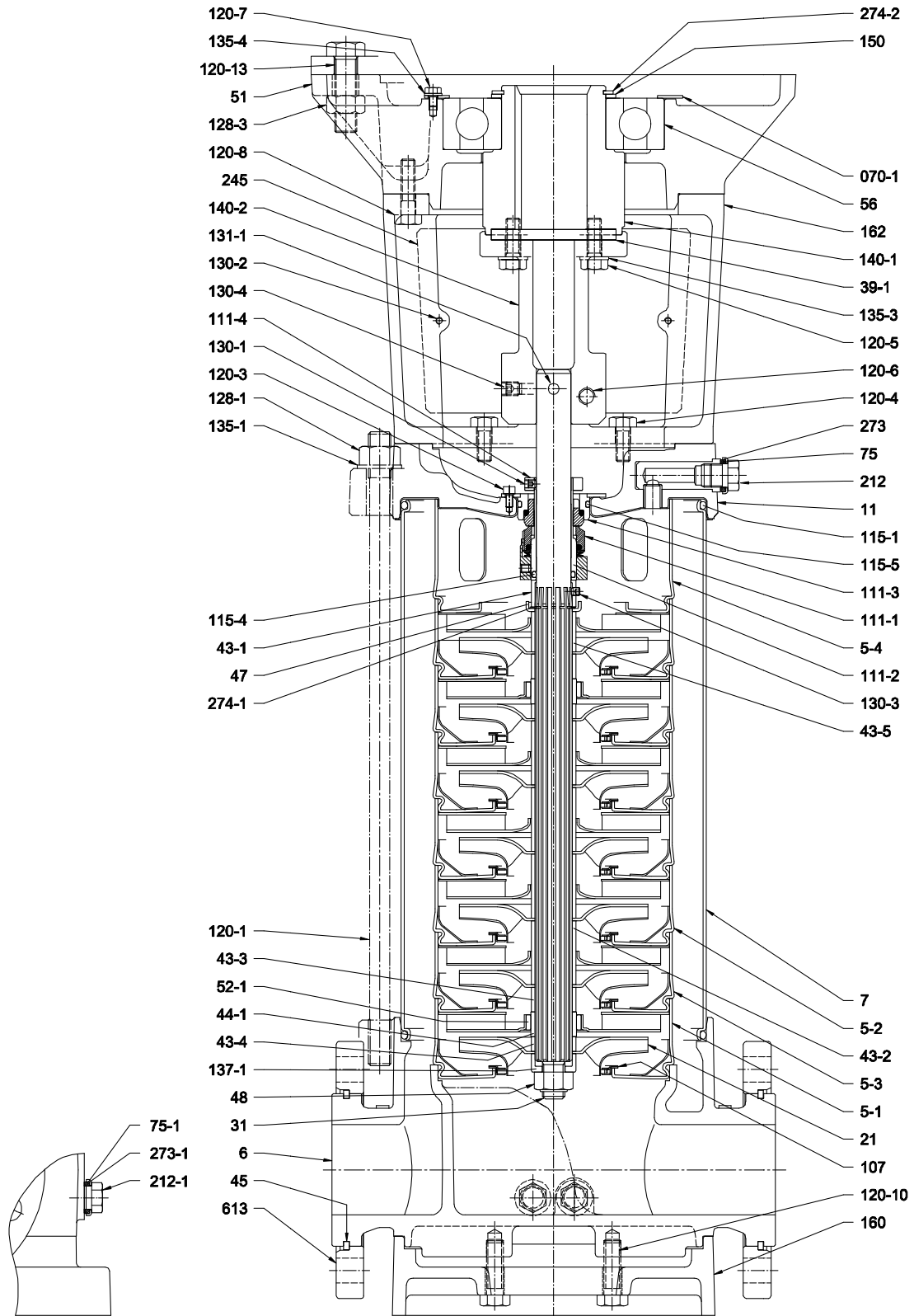

Pump with single ball bearing

SECTIONAL VIEW EVMG32

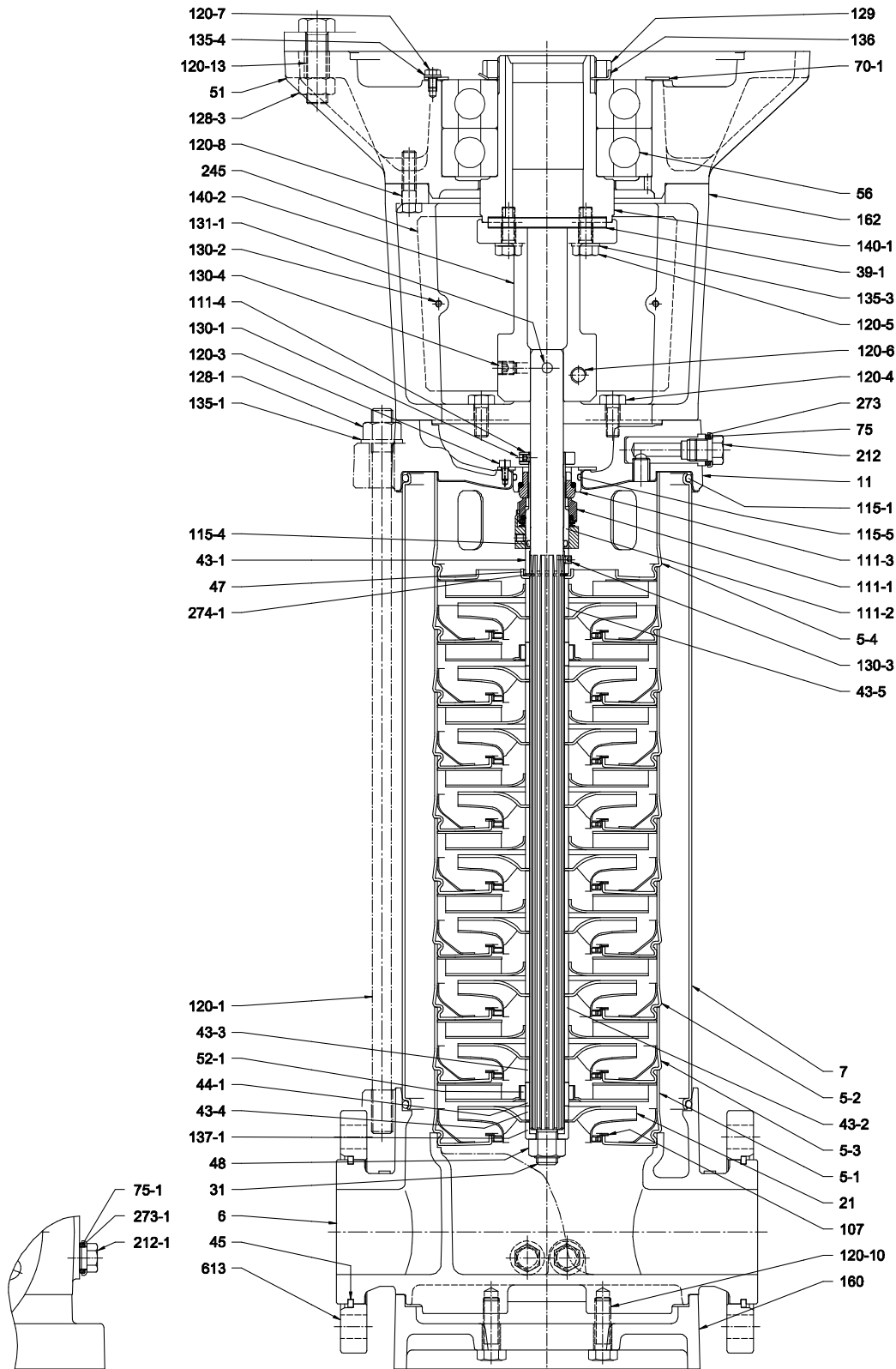

Pump with double ball bearing

EVMG32

SECTIONAL TABLE
EVMG32

N°	PART NAME	MATERIAL EVMG	DIMENSIONS	STANDARD
5-1	Suction casing	EN 1.4301 (AISI 304)		
5-2	Intermediate Casing	EN 1.4301 (AISI 304)		
5-3	Intermediate casing bearing	EN 1.4301 (AISI 304)		
5-4	Discharge casing	EN 1.4301 (AISI 304)		
6	Bottom casing	Cast Iron EN GJL-250 -EN1561		
7	Outer casing	EN 1.4301 (AISI 304)		
11	Casing cover	Cast Iron EN GJL-250 -EN1561		
21	Impeller	EN 1.4301 (AISI 304)		
21-1	Reduced impeller			
31	Shaft	EN 1.4401 (AISI 316)		
39-1	Key	Carbon Steel	12x8x90	UNI 6604
43-1	Shaft sleeve (mechanical seal)	EN 1.4301 (AISI 304)		
43-2	Shaft sleeve (intermediate)	EN 1.4301 (AISI 304)		
43-3	Shaft sleeve (bearing)	EN 1.4301 (AISI 304)		
43-4	Shaft sleeve (adjustment)	EN 1.4301 (AISI 304)		
43-5	Shaft sleeve (last stage)	EN 1.4301 (AISI 304)		
44-1	Shaft sleeve bearing	Tungsten carbide		
45	Flange holder	EN 1.402 (AISI 420)		
47	Ring Holder	EN 1.4301 (AISI 304)		
48	Impeller nut	A2-70 UNI 7323 with inox insert	M16	
51	Motor adapter	Cast iron EN-GJL-200-EN 1561		
52-1	Bearing	Tungsten carbide		
56	Ball bearing	see table page 337		
70-1	Ring for bearing	EN 1.4301 (AISI 304)		
75	O-Ring (plug)	EPDM		
75-1	O-Ring (plug)	EPDM		
107	Liner ring	PTFE / EN 1.4301 (AISI 304)		
111-1	Mechanical seal	Silicon carbide / Carbon / FPM		
111-2	Mechanical seal cartridge	EN 1.4301 (AISI 304)		
111-3	Mechanical seal seat	EN 1.4301 (AISI 304)		
111-4	Seal holder	Brass OT 58 UNI 5705		
111-5	Adjusting ring	EN 1.4301 (AISI 304)		
115-1	O-Ring (outer casing)	EPDM	D.208.91x5.34	
115-4	O-Ring (cartridge sleeve)	EPDM	D. 24,99x3,59	
115-5	O-Ring (seal cover)	EPDM	D.44.04x3.53	
120-1	Tie-rod	Galvanized steel 6.8 strenght class ISO 898/1		

SECTIONAL TABLE EVMG32

N°	PART NAME	MATERIAL EVMG	DIMENSIONS	STANDARD	
120-3	Screw	A2-70 UNI 7323	M5x10	UNI 5931	
120-4	Screw	Galvanized steel 8.8 strenght class ISO 898/1	M10x25	UNI 5739	
120-5	Screw for coupling	Galvanized steel 8.8 strenght class ISO 898/1	EVM32 1	M6x16	UNI 5931
			EVM32 2 and 2-2	M8x20	UNI 5931
			EVM32 5 to 14	M10x30	UNI 5739
120-6	Screw for coupling	Galvanized steel 8.8 strenght class ISO 898/1	EVM32 1	M6x16	UNI 5931
			EVM32 2 to 4-3	M8x20	UNI 5931
			EVM32 5 to 14	M12x30	UNI 5931
120-7	Screw	Galvanized steel 8.8 strenght class ISO 898/1	M6x10	UNI 5739	
120-8	Screw	Galvanized steel 8.8 strenght class ISO 898/1	EVM32 3 to 4	M12x25	UNI 5739
			EVM32 5 to 14	M10x30	UNI 5739
120-10	Screw	Galvanized steel 8.8 strenght class ISO 898/1	M12x40	UNI 5739	
120-13	Screw for motor	Galvanized steel 8.8 strenght class ISO 898/1	EVM32 1 to 2	M8x20	UNI 5739
			EVM32 3 to 4	M12x30	UNI 5739
			EVM32 5 to 14	M16x65	UNI 5739
128-1	Nut for tie rod	Galvanized steel	M16	UNI 5588	
128-3	Nut	Galvanized steel	M16	UNI 5588	
129	Lock nut	Carbon Steel			
130-1	Set screw	A2-70 UNI 7323	M6x8	UNI 5923	
130-2	Screw for coupling guard	A2-70 UNI 7323	M5x6	UNI 7687	
130-3	Set screw	A2-70 UNI 7323	M6x6	UNI 5923	
130-4	Set screw	Carbon steel	M10x10	UNI 5923	
131-1	Pin for shaft	Carbon Steel			
135-1	Washer	Galvanized steel	17x30x3	UNI 6592	
135-3	Washer	Galvanized steel	10.5x17.5x2.2	UNI 1751	
135-4	Washer	Plated carbon steel	06:04	UNI 1751	
136	Washer	Carbon steel			
137-1	Impeller spacer	EN 1.4301 (AISI 304)			
140	Coupling	Brass OT 58 UNI 5705			
140-1	Motor coupling	Carbon steel			
140-2	Coupling (motor side)	Carbon steel			
150	Spacer	carbon steel			
160	Base	Cast iron EN-GJL-200-EN 1561			
162	Motor bracket	Cast iron EN-GJL-200-EN 1561			
212	Plug	EN 1.4301 (AISI 304)			
212-1	Plug	EN 1.4301 (AISI 304)			
245	Coupling guard	EN 1.4301 (AISI 304)			
273	Plug Washer	EN 1.4301 (AISI 304)			
273-1	Plug Washer	EN 1.4301 (AISI 304)			
274-1	C-type snap ring (mechanical seal)	EN 1.4301 (AISI 304)	D.26	UNI 7435	
274-2	C-type snap ring (coupling)	Carbon Steel TC 80	EVM32 3 to 4	D.50	UNI 7435
			EVM32 5 to 10	D.65	UNI 7435
			EVM32 11 to 12	D.75	UNI 7535
274-3	C-type snap ring (bracket)	Carbon Steel TC 80	D.110	UNI 7437	
613	Flange	Carbon steel			

QUANTITY FOR MODEL
EVMG32

Pump Type	N°																															
	5-2	5-3	11	21	21-1	39-1	43-2	43-3	43-4	44-1	51	52-1	56	70-1	107	111-5	120-4	120-5	120-7	120-8	128-3	129	135-3	135-4	136	140	140-1	140-2	150	274-2	274-3	
EVMG32 1-0F5/2.2	/	1	/	1	/	/	/	1	1	1	/	1	/	1	/	1	1	/	2	/	/	/	/	/	/	/	/	/	/	/	/	/
EVMG32 2-2F5/3.0	/	1	/	/	2	/	/	1	1	1	/	1	/	/	2	1	/	2	/	/	/	/	/	/	/	/	1	/	/	/	/	/
EVMG32 2-0F5/4.0	/	1	/	2	/	/	/	1	1	1	/	1	/	/	2	1	/	2	/	/	/	/	/	/	/	/	1	/	/	/	/	/
EVMG32 3-3F5/5.5	1	1	/	/	3	/	1	1	1	1	1	1	1	/	3	1	/	/	/	4	/	/	/	/	/	/	/	/	1	1	1	1
EVMG32 3-1F5/5.5	1	1	/	2	1	/	1	1	1	1	1	1	1	/	3	1	/	/	/	4	/	/	/	/	/	/	1	/	/	/	/	/
EVMG32 4-3F5/7.5	2	1	/	1	3	/	2	1	1	1	1	1	1	/	4	1	/	/	/	4	/	/	/	/	/	1	/	/	1	1	1	1
EVMG32 4-1F5/7.5	2	1	/	3	1	/	2	1	1	1	1	1	1	/	4	1	/	/	/	4	/	/	/	/	/	1	/	/	1	1	1	1
EVMG32 5-3F5/11	3	1	1	2	3	1	3	1	1	1	1	1	1	1	5	1	4	4	3	4	4	4	4	3	/	/	1	1	1	1	1	/
EVMG32 5-0F5/11	3	1	1	5	/	1	3	1	1	1	1	1	1	1	5	1	4	4	3	4	4	4	4	3	/	/	1	1	1	1	1	/
EVMG32 6-3F5/11	4	1	1	3	3	1	4	1	1	1	1	1	1	1	6	1	4	4	3	4	4	4	4	3	/	/	1	1	1	1	1	/
EVMG32 6-2F5/11	4	1	1	4	2	1	4	1	1	1	1	1	1	1	6	1	4	4	3	4	4	4	4	3	/	/	1	1	1	1	1	/
EVMG32 7-3F5/15	5	1	1	4	3	1	5	1	1	1	1	1	1	1	7	1	4	4	3	4	4	4	4	3	/	/	1	1	1	1	1	/
EVMG32 7-0F5/15	5	1	1	7	/	1	5	1	1	1	1	1	1	1	7	1	4	4	3	4	4	4	4	3	/	/	1	1	1	1	1	/
EVMG32 8-3F5/15	6	1	1	5	3	1	6	1	1	1	1	1	1	1	8	1	4	4	3	4	4	4	4	3	/	/	1	1	1	1	1	/
EVMG32 8-2F5/15	6	1	1	6	2	1	6	1	1	1	1	1	1	1	8	1	4	4	3	4	4	4	4	3	/	/	1	1	1	1	1	/
EVMG32 9-3F5/18.5	7	1	1	6	3	1	7	1	1	1	1	1	1	1	9	1	4	4	3	4	4	4	4	3	/	/	1	1	1	1	1	/
EVMG32 9-0F5/18.5	7	1	1	9	/	1	7	1	1	1	1	1	1	1	9	1	4	4	3	4	4	4	4	3	/	/	1	1	1	1	1	/
EVMG32 10-3F5/18.5	7	2	1	7	3	1	7	2	2	2	1	2	1	1	10	1	4	4	3	4	4	4	4	3	/	/	1	1	1	1	1	/
EVMG32 10-2F5/18.5	7	2	1	8	2	1	7	2	2	2	1	2	1	1	10	1	4	4	3	4	4	4	4	3	/	/	1	1	1	1	1	/
EVMG32 11-3F5/22	8	2	1	8	3	1	8	2	2	2	1	2	1	1	11	1	4	4	3	4	4	4	4	3	/	/	1	1	1	1	1	/
EVMG32 11-0F5/22	8	2	1	11	/	1	8	2	2	2	1	2	1	1	11	1	4	4	3	4	4	4	4	3	/	/	1	1	1	1	1	/
EVMG32 12-3F5/22	9	2	1	9	3	1	9	2	2	2	1	2	1	1	12	1	4	4	3	4	4	4	4	3	/	/	1	1	1	1	1	/
EVMG32 13-3F5/30	10	2	1	10	3	1	10	2	2	2	1	2	1	1	13	/	4	4	3	4	4	4	4	3	/	/	1	1	1	1	1	/
EVMG32 13-0F5/30	10	2	1	13	/	1	10	2	2	2	1	2	1	1	13	/	4	4	3	4	4	4	4	3	/	/	1	1	1	1	1	/
EVMG32 14-3F5/30	11	2	1	11	3	1	11	2	2	2	1	2	1	1	14	/	4	4	3	4	4	4	4	3	/	/	1	1	1	1	1	/
EVMG32 14-0F5/30	11	2	1	14	/	1	11	2	2	2	1	2	1	1	14	/	4	4	3	4	4	4	4	3	/	/	1	1	1	1	1	/

EVMG32

BEARINGS
EVMG32

Pump Type	N° 56
EVMG32 1-0F5/2.2	/
EVMG32 2-2F5/3.0	/
EVMG32 2-0F5/4.0	/
EVMG32 3-3F5/5.5	6310 ZZ C3
EVMG32 3-1F5/5.5	6310 ZZ C3
EVMG32 4-3F5/7.5	6310 ZZ C3
EVMG32 4-1F5/7.5	6310 ZZ C3
EVMG32 5-3F5/11	6313 ZZ C3
EVMG32 5-0F5/11	6313 ZZ C3
EVMG32 6-3F5/11	6313 ZZ C3
EVMG32 6-2F5/11	6313 ZZ C3
EVMG32 7-3F5/15	6313 ZZ C3
EVMG32 7-0F5/15	6313 ZZ C3
EVMG32 8-3F5/15	6313 ZZ C3
EVMG32 8-2F5/15	6313 ZZ C3
EVMG32 9-3F5/18.5	6313 ZZ C3
EVMG32 9-0F5/18.5	6313 ZZ C3
EVMG32 10-3F5/18.5	6313 ZZ C3
EVMG32 10-2F5/18.5	6313 ZZ C3
EVMG32 11-3F5/22	6315 ZZ C3
EVMG32 11-0F5/22	6315 ZZ C3
EVMG32 12-3F5/22	6315 ZZ C3
EVMG32 13-3F5/30	6315 ZZDT C3 *
EVMG32 13-0F5/30	6315 ZZDT C3 *
EVMG32 14-3F5/30	6315 ZZDT C3 *
EVMG32 14-0F5/30	6315 ZZDT C3 *

*DT=Two single row deep groove ball bearings matched for paired mounting in a tandem arrangement.

PERFORMANCE CURVE EVM(L)45

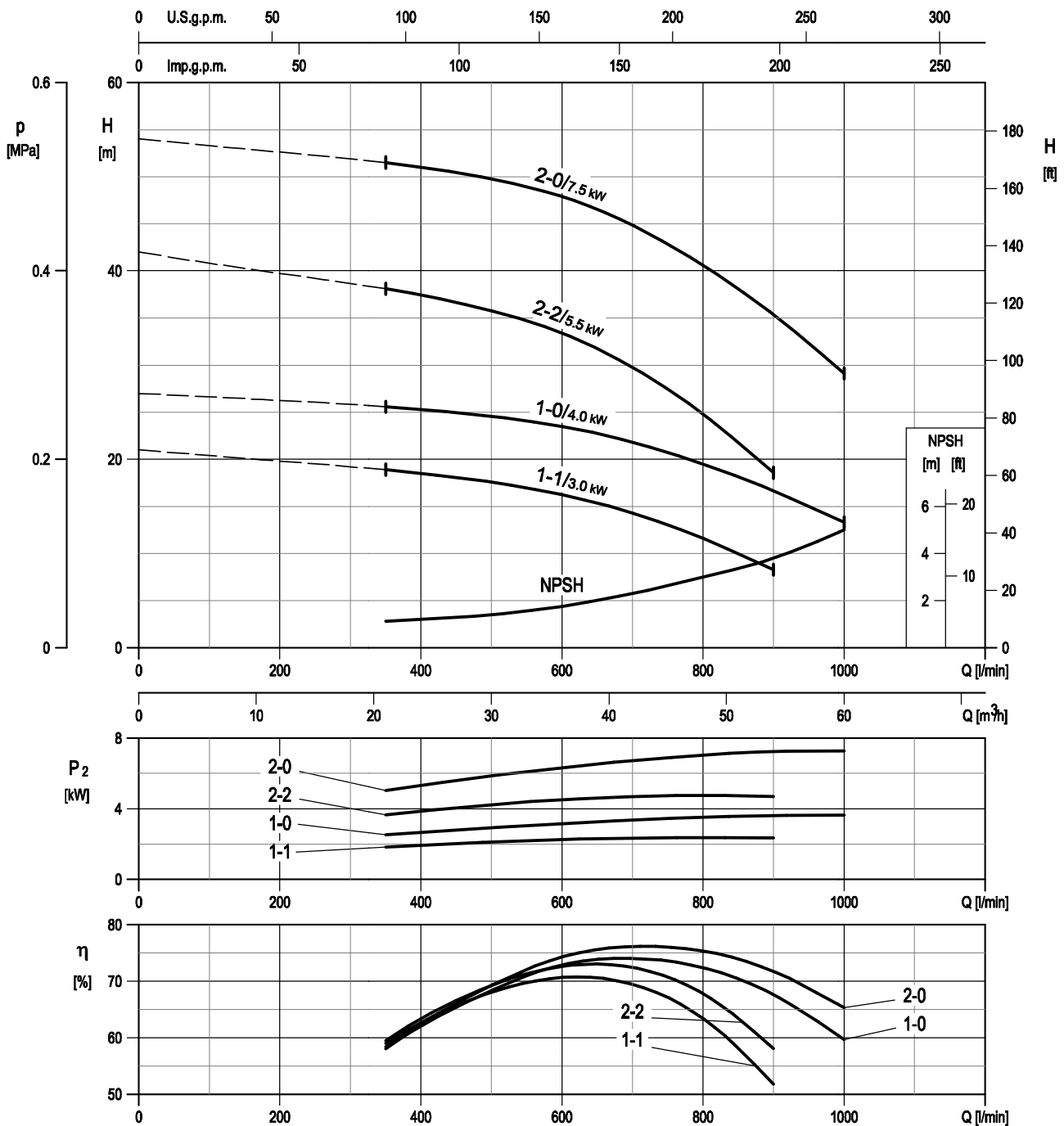

Rotation speed $\approx 2900 \text{ min}^{-1}$
 Test standard: ISO 9906:2012 - Grade 3B

PERFORMANCE CURVE
EVM(L)45

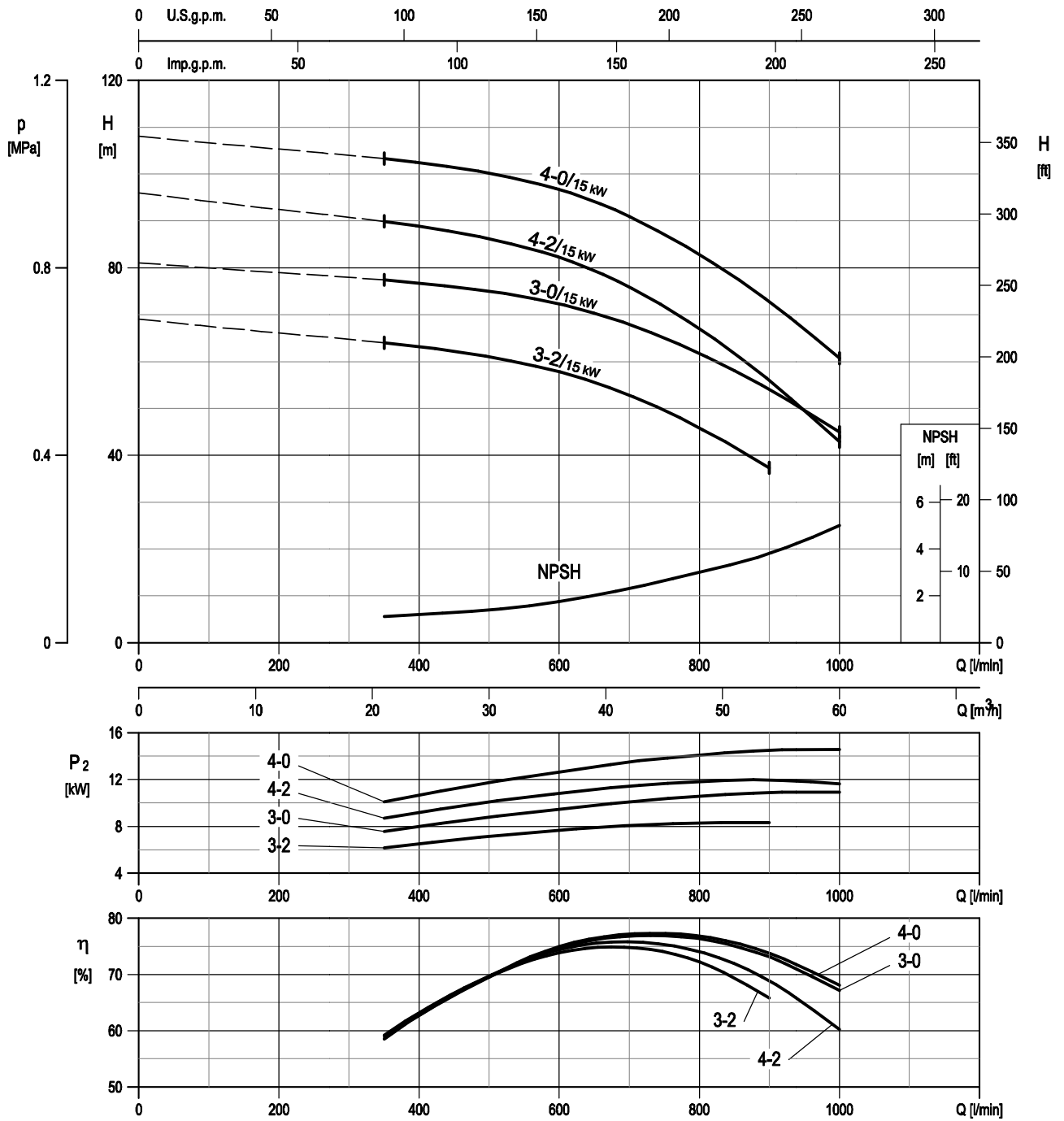

Rotation speed $\approx 2900 \text{ min}^{-1}$
Test standard: ISO 9906:2012 - Grade 3B

PERFORMANCE CURVE EVM(L)45

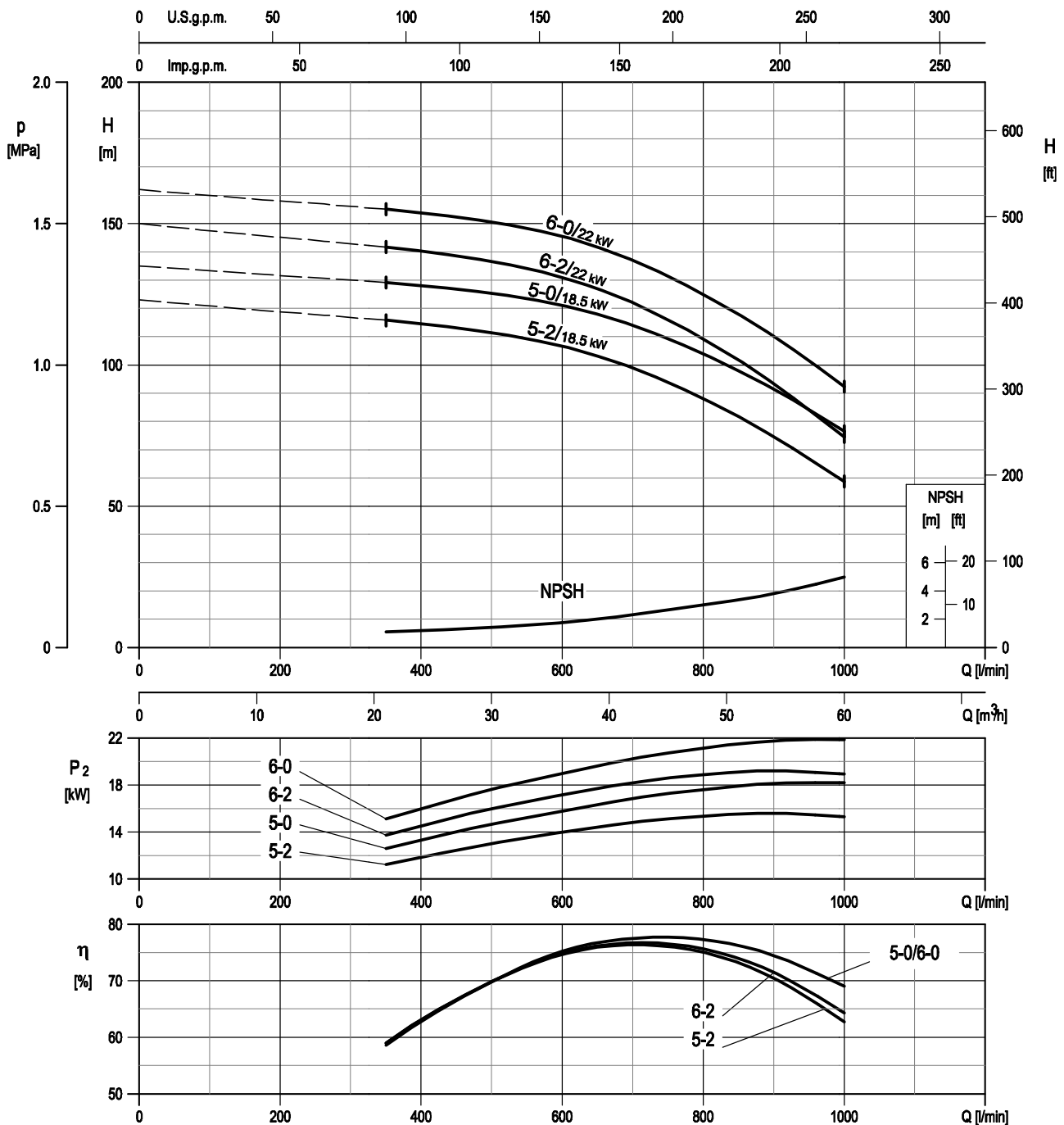

Rotation speed $\approx 2900 \text{ min}^{-1}$
 Test standard: ISO 9906:2012 - Grade 3B

EVM(L)45

PERFORMANCE CURVE
EVM(L)45

EVM(L)45

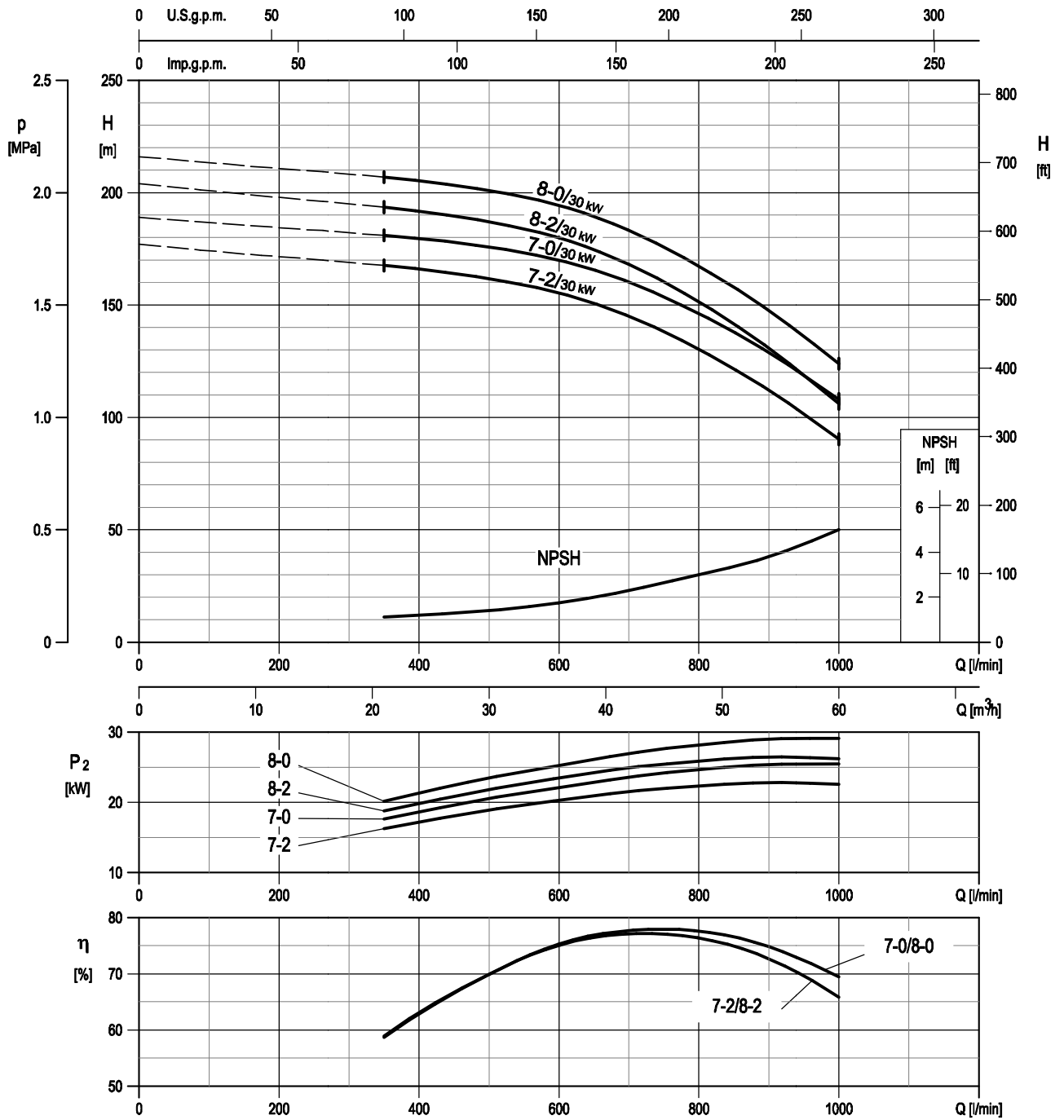

PERFORMANCE CURVE EVM(L)45

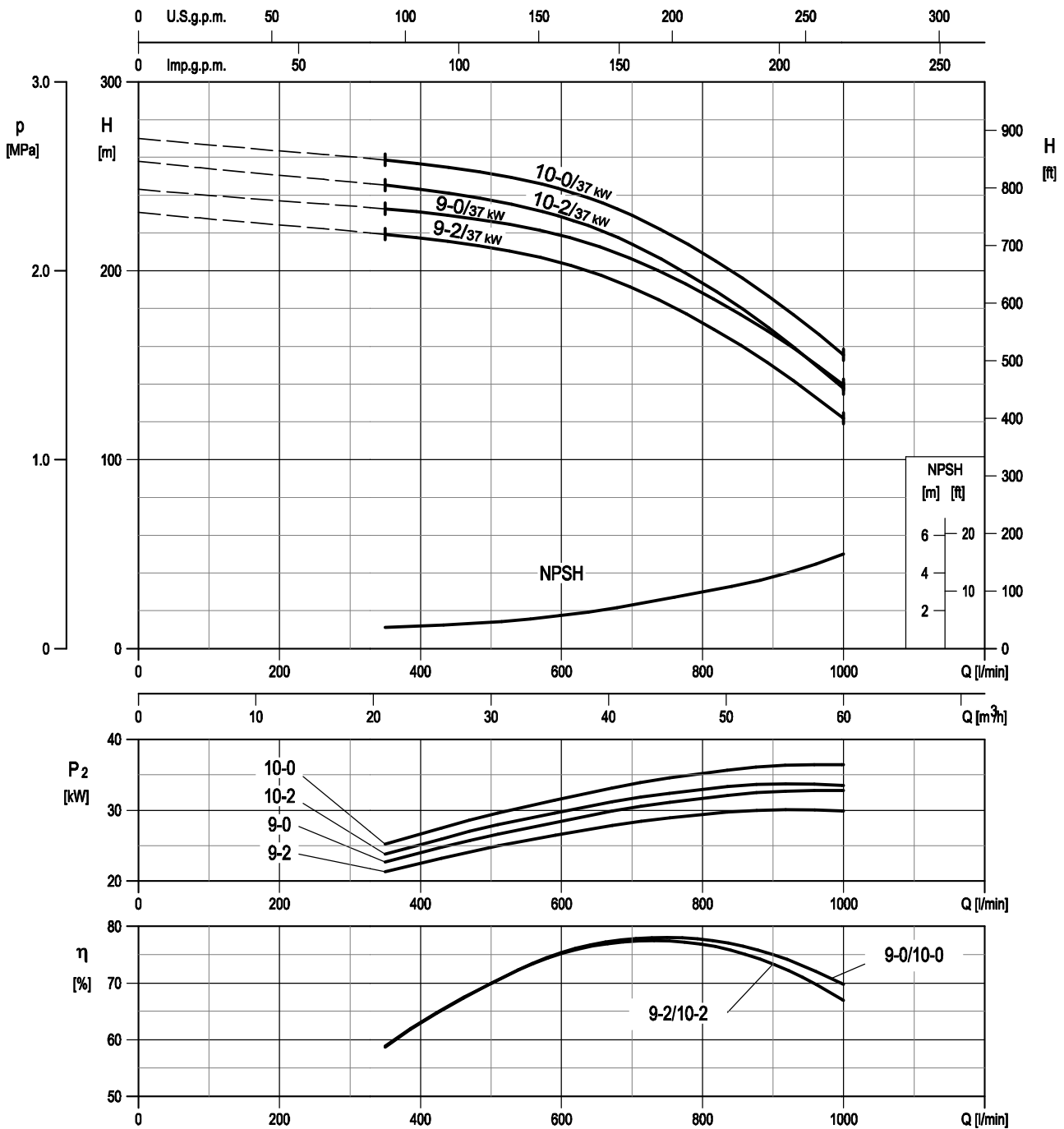

Rotation speed $\approx 2900 \text{ min}^{-1}$
 Test standard: ISO 9906:2012 - Grade 3B

TECHNICAL DATA
EVM(L)45

Dimensional sketch

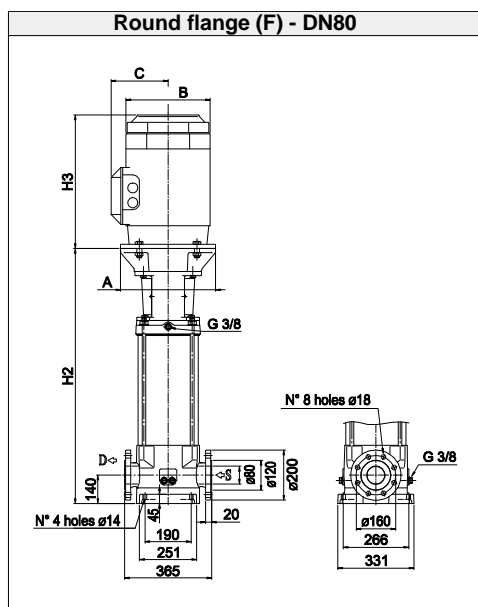

Dimensions [mm] and Weights [Kg]

Pump Type	Pmax [MPa]	kW	Size	Motor			H2	Round flange (F)		
				A	3 -			Weight Pump	Weight Pump + Motor	
					B	C	H3			
EVM(L)45 1-1F5/3.0	1.6	3.0	100 L	160	196	155	306	525	71	93.8
EVM(L)45 1-0F5/4.0	1.6	4.0	112 M	160	196	155	306	525	73	95.8
EVM(L)45 2-2F5/5.5	1.6	5.5	132 S	300	225	160	328	618	81	119.6
EVM(L)45 2-0F5/7.5	1.6	7.5	132 S	300	225	160	350	618	81	121.4
EVM(L)45 3-2F5/11	1.6	11	160 M	350	248	194	476	821	99	161.5
EVM(L)45 3-0F5/11	1.6	11	160 M	350	248	194	476	821	99	161.5
EVM(L)45 4-2F5/15	2.5	15	160 M	350	317	238	498	893	108	196.9
EVM(L)45 4-0F5/15	2.5	15	160 M	350	317	238	498	893	108	196.9
EVM(L)45 5-2F5/18.5	2.5	18.5	160 L	350	317	238	542	965	128	232
EVM(L)45 5-0F5/18.5	2.5	18.5	160 L	350	317	238	542	965	128	232
EVM(L)45 6-2F5/22	2.5	22	180 M	350	360	268	577	1037	133	296
EVM(L)45 6-0F5/22	2.5	22	180 M	350	360	268	577	1037	133	296
EVM(L)45 7-2F5/30	2.5	30	200 L	400	399	300	658	1124	139	367
EVM(L)45 7-0F5/30	2.5	30	200 L	400	399	300	658	1124	139	367
EVM(L)45 8-2F5/30	2.5	30	200 L	400	399	300	658	1196	146	374
EVM(L)45 8-0F5/30	2.5	30	200 L	400	399	300	658	1196	146	374
EVM(L)45 9-2F5/30	2.5	30	200 L	400	399	300	658	1269	151	379
EVM(L)45 9-0F5/37	2.5	37	200 L	400	399	300	658	1269	151	393
EVM(L)45 10-2F5/37	3.0	37	200 L	400	399	300	658	1341	156	398
EVM(L)45 10-0F5/37	3.0	37	200 L	400	399	300	658	1341	156	398

1.6 MPa=16 bar ; 2.5 MPa=25 bar ; 3.0 MPa=30 bar

SECTIONAL VIEW EVM(L)45

EVM(L)45

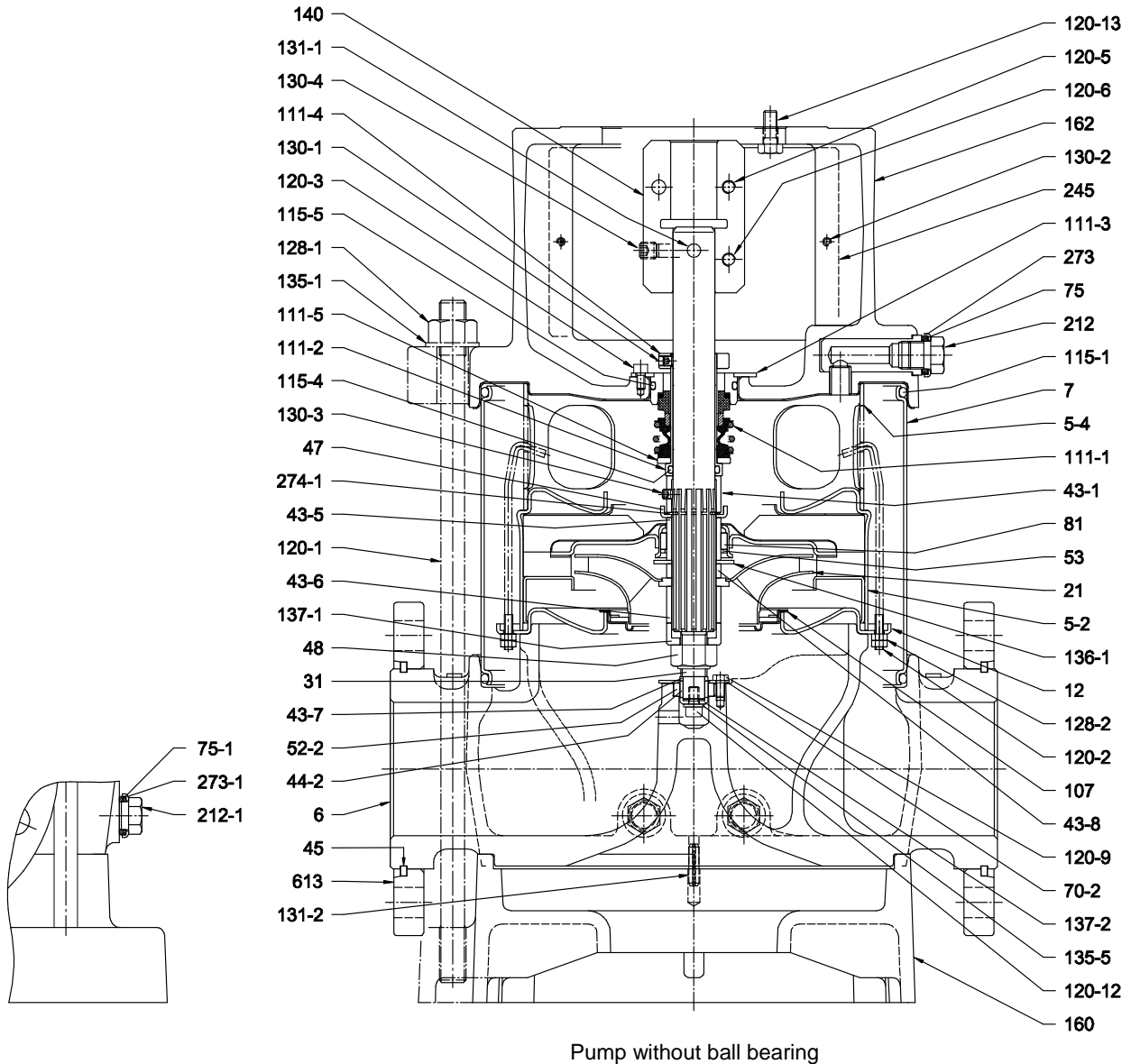

SECTIONAL VIEW
EVM(L)45

EVM(L)45

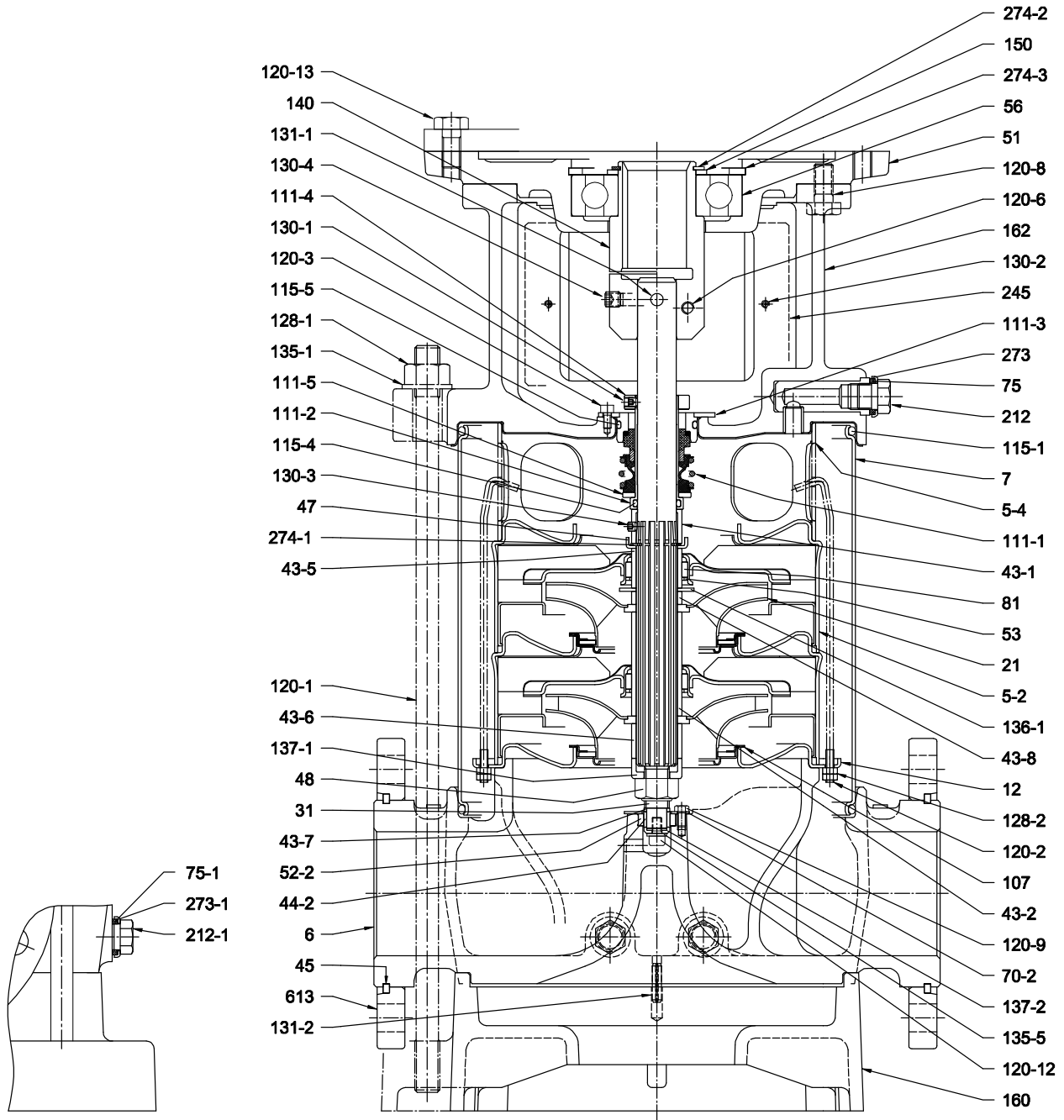

Pump with single ball bearing

SECTIONAL VIEW EVM(L)45

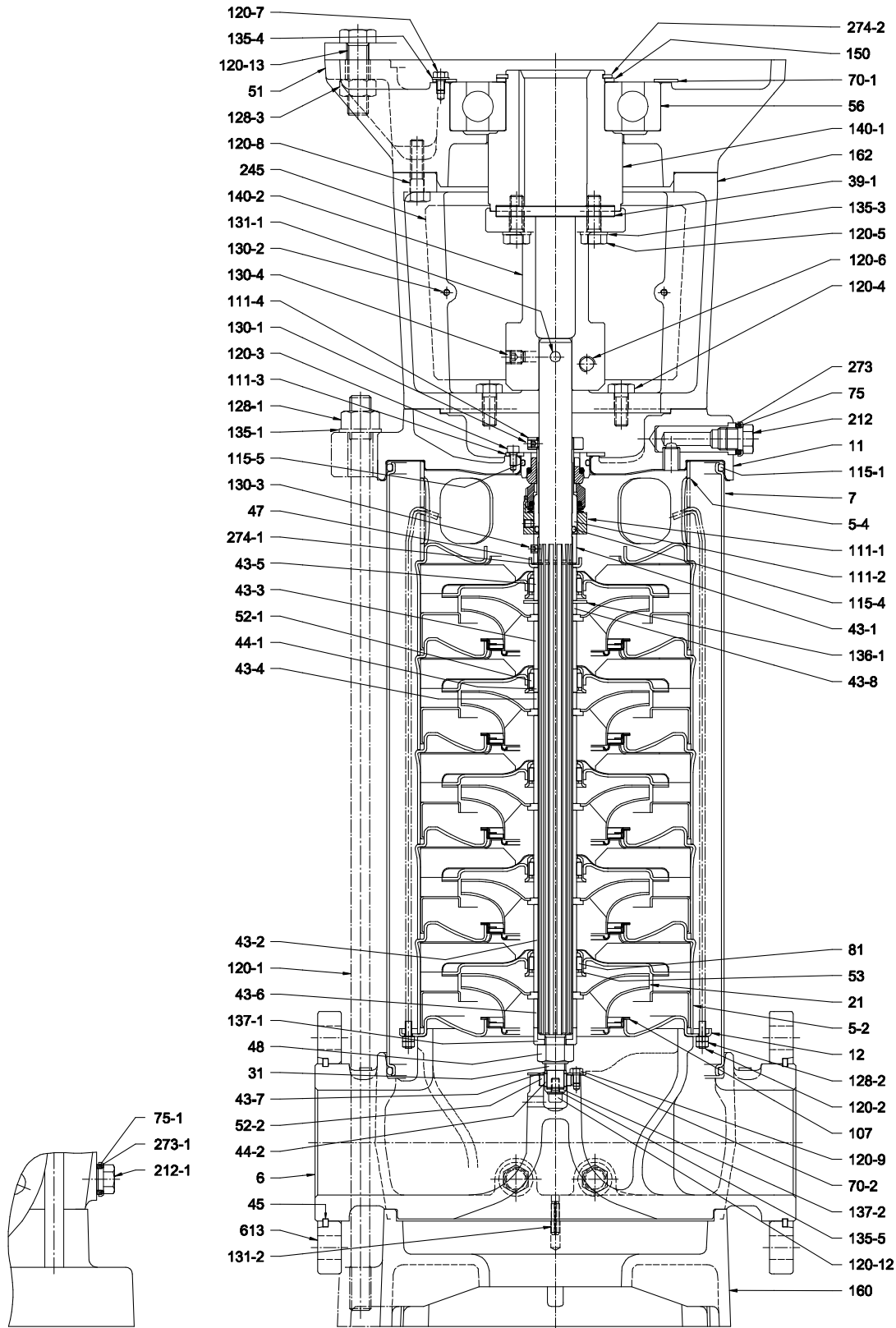

Pump with single ball bearing

EVM(L)45

SECTIONAL VIEW
EVM(L)45

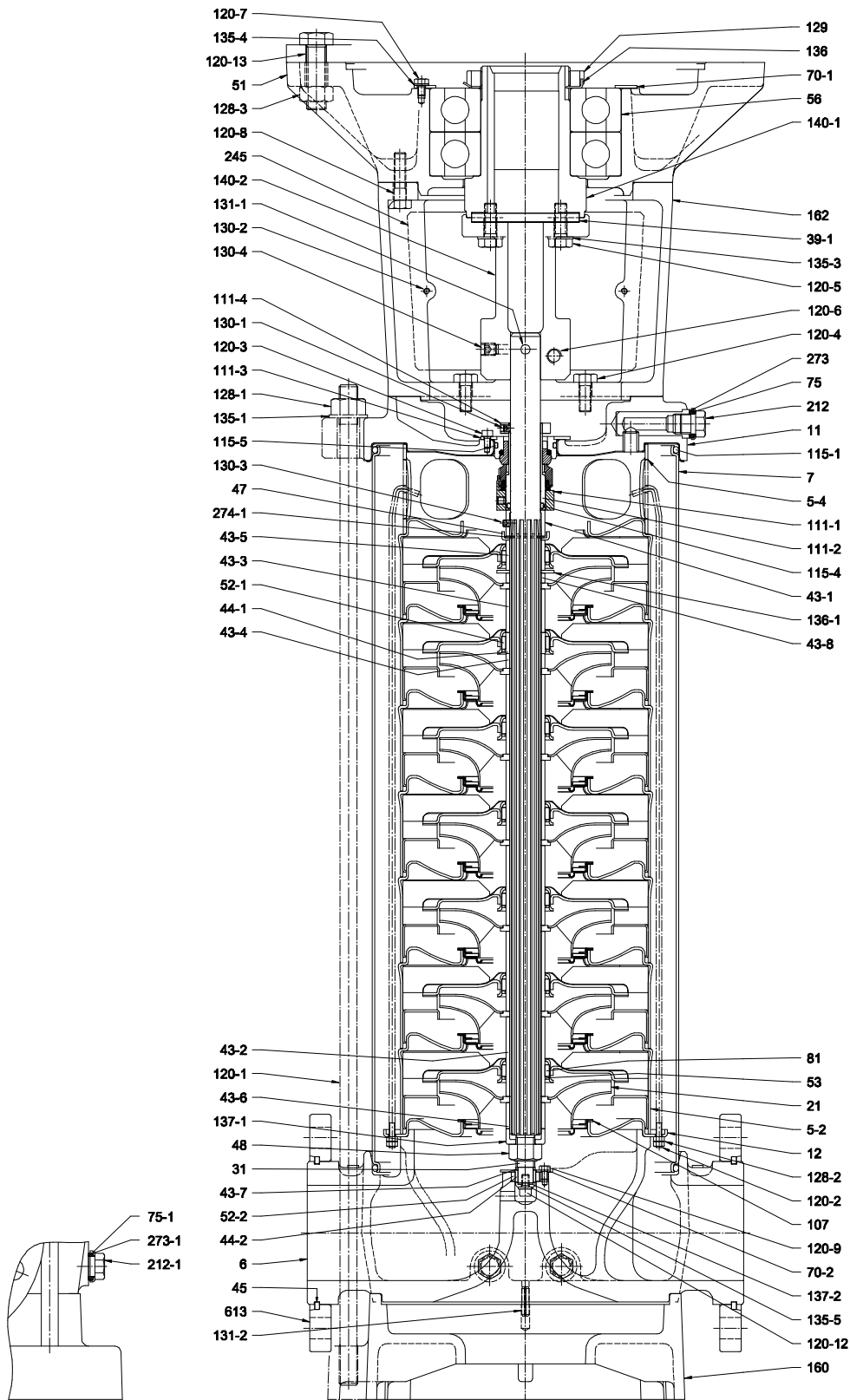

Pump with double ball bearing

SECTIONAL TABLE EVM(L)45

N°	PART NAME	MATERIAL		DIMENSIONS	STANDARD
		EVM	EVML		
5-2	Intermediate casing	EN 1.4301 (AISI 304)	EN 1.4401 (AISI 316)		
5-4	Discharge casing	EN 1.4301 (AISI 304)	EN 1.4401 (AISI 316)		
6	Bottom casing	EN. 1.4308 (ASTM CF8)	EN. 1.4408 (ASTM CF8M)		
7	Outer casing	EN 1.4301 (AISI 304)	EN 1.4401 (AISI 316)		
11	Casing cover	Cast iron + EN 1.4301 (AISI 304)	Cast iron + EN 1.4401 (AISI 316)		
12	Suction cover	EN. 1.1301 (AISI304)	EN 1.4401 (AISI 316)		
21	Impeller				
21-1	Reduced impeller	EN 1.4301 (AISI 304)	EN 1.4401 (AISI 316)		
31	Shaft	EN 1.4401 (AISI 316)			
39-1	Key	Carbon steel		12x8x90	UNI 6604
43-1	Shaft sleeve (mechanical seal)	EN 1.4301 (AISI 304)	EN 1.4401 (AISI 316)		
43-2	Shaft sleeve (intermediate)	EN 1.4301 (AISI 304)	EN 1.4401 (AISI 316)		
43-3	Shaft sleeve (bearing)	EN 1.4301 (AISI 304)	EN 1.4401 (AISI 316)		
43-4	Shaft sleeve (adjustment)	EN 1.4301 (AISI 304)	EN 1.4401 (AISI 316)		
43-5	Shaft sleeve (last stage)	EN 1.4301 (AISI 304)	EN 1.4401 (AISI 316)		
43-6	Shaft sleeve (adjustment)	EN 1.4301 (AISI 304)	EN 1.4401 (AISI 316)		
43-7	Shaft sleeve	EN 1.4301 (AISI 304)	EN 1.4401 (AISI 316)		
43-8	Shaft sleeve (discharge-lower)	EN 1.4301 (AISI 304)	EN 1.4401 (AISI 316)		
44-1	Shaft sleeve bearing	Tungsten carbide			
44-2	Bearing sleeve (bottom bearing)	Tungsten carbide			
45	Flange holder	EN 1.402 (AISI 420)			
47	Ring holder	EN 1.4301 (AISI 304)	EN 1.4401 (AISI 316)		
48	Impeller nut	A2-70 UNI 7323 with inox insert	A4-70 UNI 7323 with inox insert	M16	
51	Motor adapter	Cast iron EN-GJL-200-EN 1561			
52-1	Bearing	Tungsten carbide			
52-2	Bearing	Tungsten carbide			
53	Bush holder	EN 1.4301 (AISI 304)	EN 1.4401 (AISI 316)		
56	Ball bearing	see table page 350			
70-1	Ring for bearing	EN 1.4301 (AISI 304)			
70-2	Ring for bearing	EN 1.4301 (AISI 304)	EN 1.4401 (AISI 316)		
75	O-Ring (plug)	EPDM	FPM		
75-1	O-Ring (plug)	EPDM	FPM		
81	Bush	PTFE			
107	Liner ring	PTFE /EN 1.4401 (AISI316)			
111-1	Mechanical seal	Silicon carbide/Carbon/FPM			
111-2	Mechanical seal cartridge	EN 1.4301 (AISI 304)	EN 1.4401 (AISI 316)		
111-3	Mechanical seal seat	EN 1.4301 (AISI 304)	EN 1.4401 (AISI 316)		
111-4	Seal holder	Brass OT 58 UNI 5705	EN 1.4401 (AISI 316)		
111-5	Adjusting ring	EN 1.4301 (AISI 304)	EN 1.4401 (AISI 316)		
115-1	O-Ring (outer casing)	EPDM	FPM	D.240.66x5.34	
115-4	O-Ring (cartridge sleeve)	EPDM	FPM	D.24.99x3.53	
115-5	O-Ring (seal cover)	EPDM	FPM	D.44.04x3.53	
120-1	Tie Rod	Galvanized steel 6.8 strenght class ISO 898/1			

SECTIONAL TABLE
EVM(L)45

N°	PART NAME	MATERIAL		DIMENSIONS	STANDARD
		EVM	EVML		
120-2	Tie Rod	EN 1.4301 (AISI 304)	EN 1.4401 (AISI 316)		
120-3	Screw	A2-70 UNI 7323		M5x10	UNI 5931
120-4	Screw	Galvanized steel 8.8 strenght class ISO 898/1		M10x25	UNI 5739
120-5	Screw for coupling	EVM45 1-0 and 1-1 EVM45 3 to 10	Galvanized steel 8.8 strenght class ISO 898/1	M8x20	UNI 5931
				M10x30	UNI 5739
120-6	Screw for coupling	EVM45 1 to 2 EVM45 3 to 10	Galvanized steel 8.8 strenght class ISO 898/1	M8x20	UNI 5931
				M12x30	UNI 5931
120-7	Screw	Galvanized steel 8.8 strenght class ISO 898/1		M6X10	UNI 5739
120-8	Screw	EVM45 2 -0 and 2-2 EVM45 3 to 10	Galvanized steel 8.8 strenght class ISO 898/1	M12x25	UNI 5739
				M10x30	UNI 5739
120-9	Screw	EVM45	EN 1.4301 (AISI 304)	M5x8	UNI 5737
		EVM, EVMG	EN 1.4401 (AISI 316)		UNI 5739
120-12	Screw	EN 1.4301 (AISI 304)	EN 1.4401 (AISI 316)	M6x20	UNI 5931
120-13	Screw	EVM45 1-0, 1-1 EVM45 2-0, 2-2 EVM45 9-0, 10-0, 10-2 EVM45 9-0, 10-0, 10-2 EVM45 3-0 to 9-2	Galvanized steel 8.8 strenght class ISO 898/1	M8x20	UNI 5739
				M12x30	UNI 5739
				M6x10	UNI 5739
				M16x55	UNI 5737
				M16x65	UNI 5739
128-1	Nut for tie rod	Galvanized steel		M16	UNI 5588
128-2	Nut	Carbon steel	EN 1.4401 (AISI 316)	M5	UNI 5588
128-3	Nut	Galvanized steel		M16	UNI 5588
129	Lock nut	Carbon steel		M75x2	
130-1	Set screw	A2- 70 UNI 7323		M6x8	UNI 5923
130-2	Screw for coupling guard	A2-70 UNI 7323		M5x6	UNI 7687
130-3	Set screw	A2- 70 UNI 7323		M6x6	UNI 5923
130-4	Set screw	Carbon steel		M10x10	UNI 5923
131-1	Pin for shaft	Carbon steel			
131-2	Elastic pin	Galvanized steel		6x25	UNI 6873
135-1	Washer	Galvanized steel		17x30x3	UNI 6592
135-3	Washer	Galvanized steel		10.5x17.5x2.2	UNI 1751
135-4	Washer	Plated carbon steel		6,4	UNI 1751
135-5	Washer	EN 1.4301 (AISI 304)	EN 1.4401 (AISI 316)		
136	Bearing washer	Carbon steel			
136-1	Stopper ring	EN 1.4301 (AISI 304)	EN 1.4401 (AISI 316)		
137-1	Impeller spacer	EN 1.4301 (AISI 304)	EN 1.4401 (AISI 316)		
137-2	Shaft spacer	EN 1.4301 (AISI 304)	EN 1.4401 (AISI 316)		
140	Coupling	Brass OT 58 UNI 5705			
140-1	Motor coupling	Carbon steel			
140-2	Coupling (pump side)	Carbon steel			
150	Spacer	Carbon steel			
160	Base	Cast iron EN-GJL-200 EN1561			
162	Mator bracket	Cast iron EN-GJL-200 EN1561			
212	Plug	EN 1.4301 (AISI 304)	EN 1.4401 (AISI 316)		
212-1	Plug	EN 1.4301 (AISI 304)	EN 1.4401 (AISI 316)		
245	Coupling guard	EN 1.4301 (AISI 304)			
273	Plug washer	EN 1.4301 (AISI 304)	EN 1.4401 (AISI 316)		
273-1	Plug washer	EN 1.4301 (AISI 304)	EN 1.4401 (AISI 316)		
274-1	C-type snap ring	EN 1.4301 (AISI 304)	EN 1.4401 (AISI 316)	D.26	UNI 7435
274-2	C-Typr snap ring	EVM45 2-0, 2-2 EVM45 3 to 5 EVM45 6-0 and 6-2	Carbon steel TC80	D.50	UNI 7435
				D.65	UNI 7435
				D.75	UNI 7535
274-3	C-Typr snap ring	Carbon steel TC80		D.110	UNI 7437
613	Flange	Carbon steel			

QUANTITY FOR MODEL EVM(L)45

Pump Type	N°																														
	5-2	11	21	21-1	39-1	43-2	43-3	43-4	44-1	51	52-1	53	56	70-1	81	107	120-4	120-5	120-7	120-8	128-3	129	135-3	135-4	136	140	140-1	140-2	150	274-2	274-3
EVM(L)45 1-1F5/3.0	1	/	/	1	/	/	/	/	/	/	/	1	/	/	1	1	/	2	/	/	/	/	/	/	1	1	/	/	/	/	/
EVM(L)45 1-0F5/4.0	1	/	1	/	/	/	/	/	/	/	1	/	/	1	1	/	2	/	/	/	/	/	/	1	1	/	/	/	/	/	/
EVM(L)45 2-2F5/5.5	2	/	/	2	/	1	/	/	/	1	/	2	1	/	2	2	/	/	/	4	/	/	/	/	1	1	/	/	1	1	1
EVM(L)45 2-0F5/7.5	2	/	2	/	/	1	/	/	/	1	/	2	1	/	2	2	/	/	/	4	/	/	/	/	1	1	/	/	1	1	1
EVM(L)45 3-2F5/11	3	1	1	2	1	2	/	/	/	1	/	3	1	1	3	3	4	4	3	4	4	4	/	4	3	/	/	1	1	1	1
EVM(L)45 3-0F5/11	3	1	3	/	1	2	/	/	/	1	/	3	1	1	3	3	4	4	3	4	4	/	4	3	/	/	1	1	1	1	/
EVM(L)45 4-2F5/15	4	1	2	2	1	2	1	1	1	1	1	4	1	1	3	4	4	4	3	4	4	/	4	3	/	/	1	1	1	1	/
EVM(L)45 4-0F5/15	4	1	4	/	1	2	1	1	1	1	1	4	1	1	3	4	4	4	3	4	4	/	4	3	/	/	1	1	1	1	/
EVM(L)45 5-2F5/18.5	5	1	3	2	1	3	1	1	1	1	1	5	1	1	4	5	4	4	3	4	4	/	4	3	/	/	1	1	1	1	/
EVM(L)45 5-0F5/18.5	5	1	5	/	1	3	1	1	1	1	1	5	1	1	4	5	4	4	3	4	4	/	4	3	/	/	1	1	1	1	/
EVM(L)45 6-2F5/22	6	1	4	2	1	4	1	1	1	1	1	6	1	1	5	6	4	4	3	4	4	/	4	3	/	/	1	1	1	1	/
EVM(L)45 6-0F5/22	6	1	6	/	1	4	1	1	1	1	1	6	1	1	5	6	4	4	3	4	4	/	4	3	/	/	1	1	1	1	/
EVM(L)45 7-2F5/30	7	1	5	2	1	5	1	1	1	1	1	7	1	1	6	7	4	4	3	4	4	1	4	3	1	/	1	1	/	/	/
EVM(L)45 7-0F5/30	7	1	7	/	1	5	1	1	1	1	1	7	1	1	6	7	4	4	3	4	4	1	4	3	1	/	1	1	/	/	/
EVM(L)45 8-2F5/30	8	1	6	2	1	6	1	1	1	1	1	8	1	1	7	8	4	4	3	4	4	1	4	3	1	/	1	1	/	/	/
EVM(L)45 8-0F5/30	8	1	8	/	1	6	1	1	1	1	1	8	1	1	7	8	4	4	3	4	4	1	4	3	1	/	1	1	/	/	/
EVM(L)45 9-2F5/30	9	1	7	2	1	7	1	1	1	1	1	9	1	1	8	9	4	4	3	4	4	1	4	3	1	/	1	1	/	/	/
EVM(L)45 9-0F5/37	9	1	9	/	1	7	1	1	1	1	1	9	1	1	8	9	4	4	3	4	4	1	4	3	1	/	1	1	/	/	/
EVM(L)45 10-2F5/37	10	1	8	2	1	8	1	1	1	1	1	10	1	1	9	10	4	4	3	4	4	1	4	3	1	/	1	1	/	/	/
EVM(L)45 10-0F5/37	10	1	10	/	1	8	1	1	1	1	1	10	1	1	9	10	4	4	3	4	4	1	4	3	1	/	1	1	/	/	/

BEARINGS EVM(L)45

Pump Type	N° 56
EVM(L)45 1-1F5/3.0	/
EVM(L)45 1-0F5/4.0	/
EVM(L)45 2-2F5/5.5	6310 ZZ C3
EVM(L)45 2-0F5/7.5	6310 ZZ C3
EVM(L)45 3-2F5/11	6313 ZZ C3
EVM(L)45 3-0F5/11	6313 ZZ C3
EVM(L)45 4-2F5/15	6313 ZZ C3
EVM(L)45 4-0F5/15	6313 ZZ C3
EVM(L)45 5-2F5/18.5	6313 ZZ C3
EVM(L)45 5-0F5/18.5	6313 ZZ C3
EVM(L)45 6-2F5/22	6315 ZZ C3
EVM(L)45 6-0F5/22	6315 ZZ C3
EVM(L)45 7-2F5/30	6315 ZZDT C3 *
EVM(L)45 7-0F5/30	6315 ZZDT C3 *
EVM(L)45 8-2F5/30	6315 ZZDT C3 *
EVM(L)45 8-0F5/30	6315 ZZDT C3 *
EVM(L)45 9-2F5/30	6315 ZZDT C3 *
EVM(L)45 9-0F5/37	6315 ZZDT C3 *
EVM(L)45 10-2F5/37	6315 ZZDT C3 *
EVM(L)45 10-0F5/37	6315 ZZDT C3 *

*DT=Two single row deep groove ball bearings matched for paired mounting in a tandem arrangement.

PERFORMANCE CURVE
EVMG45

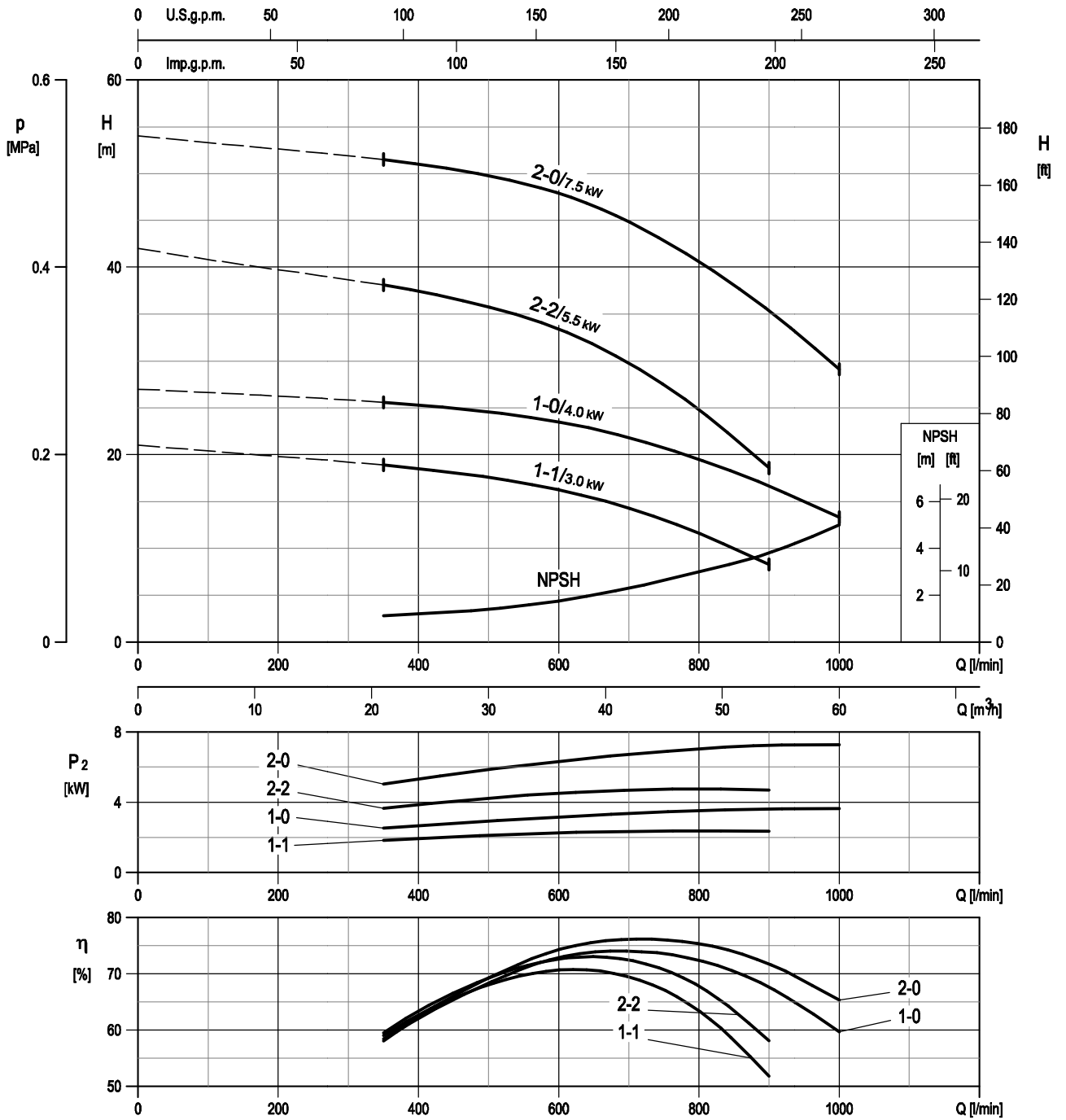

Rotation speed $\approx 2900 \text{ min}^{-1}$
Test standard: ISO 9906:2012 - Grade 3B

PERFORMANCE CURVE EVMG45

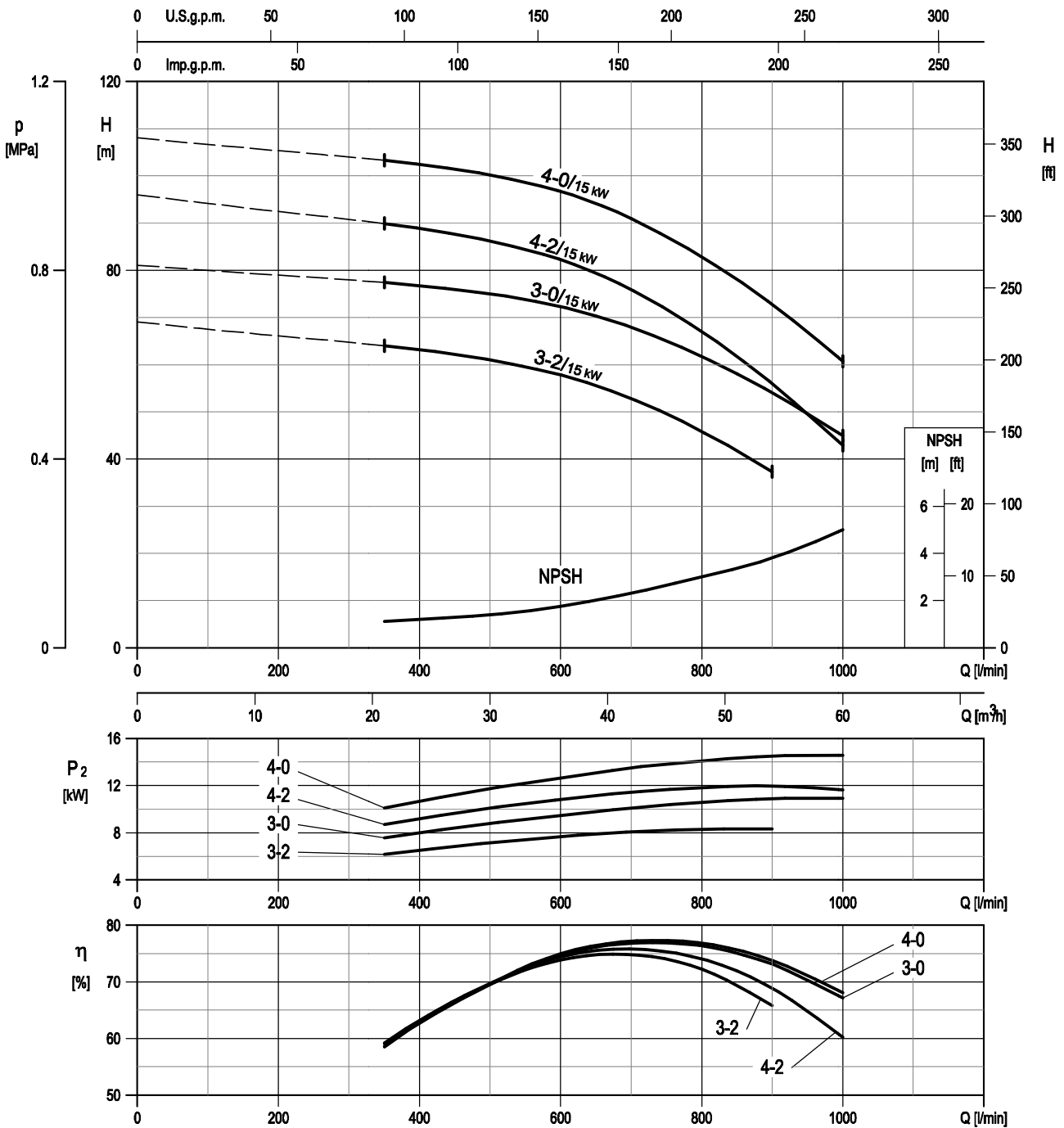

Rotation speed $\approx 2900 \text{ min}^{-1}$
 Test standard: ISO 9906:2012 - Grade 3B

PERFORMANCE CURVE
EVMG45

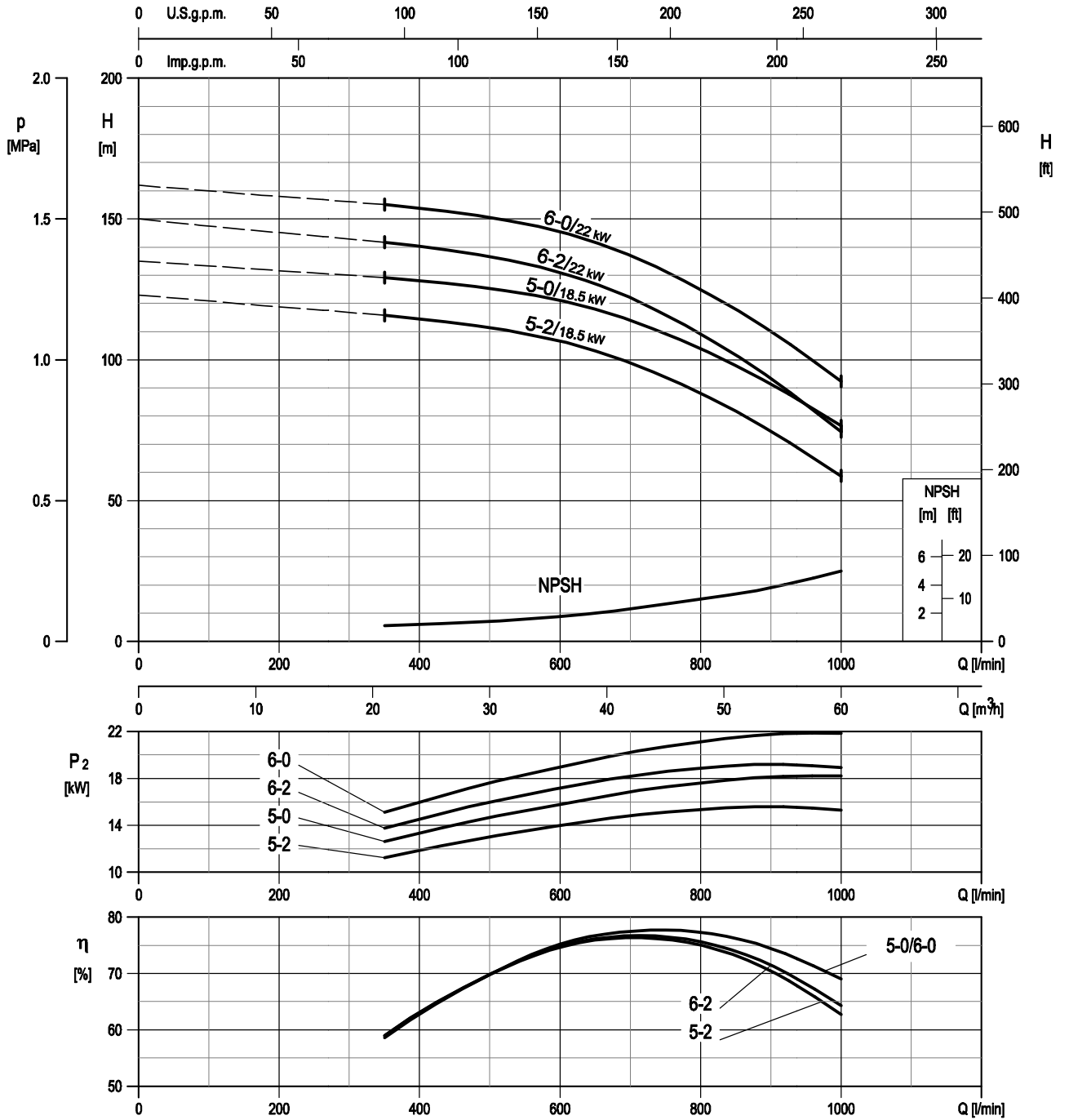

Rotation speed $\approx 2900 \text{ min}^{-1}$
Test standard: ISO 9906:2012 - Grade 3B

PERFORMANCE CURVE EVMG45

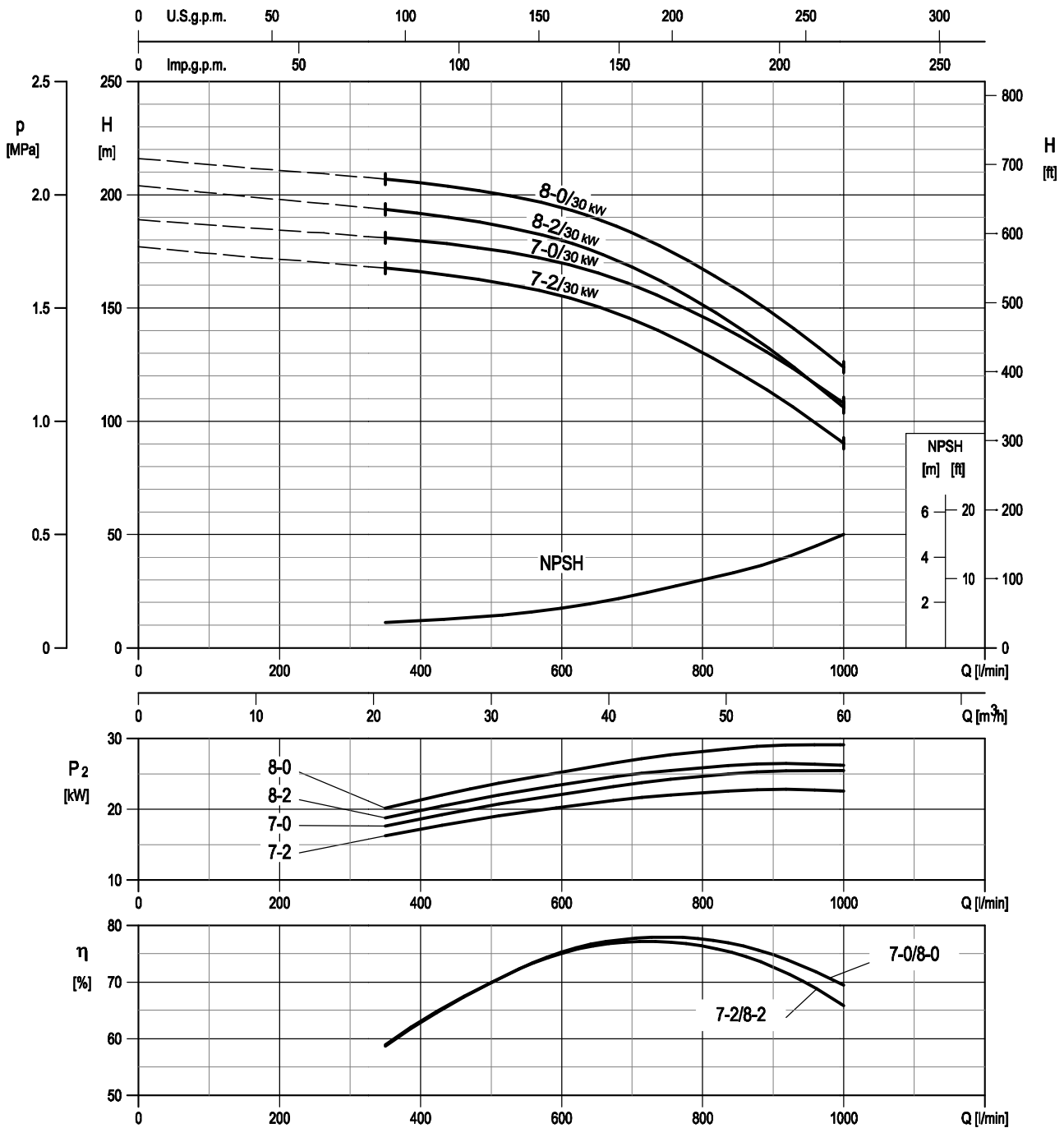

Rotation speed $\approx 2900 \text{ min}^{-1}$
 Test standard: ISO 9906:2012 - Grade 3B

PERFORMANCE CURVE
EVMG45

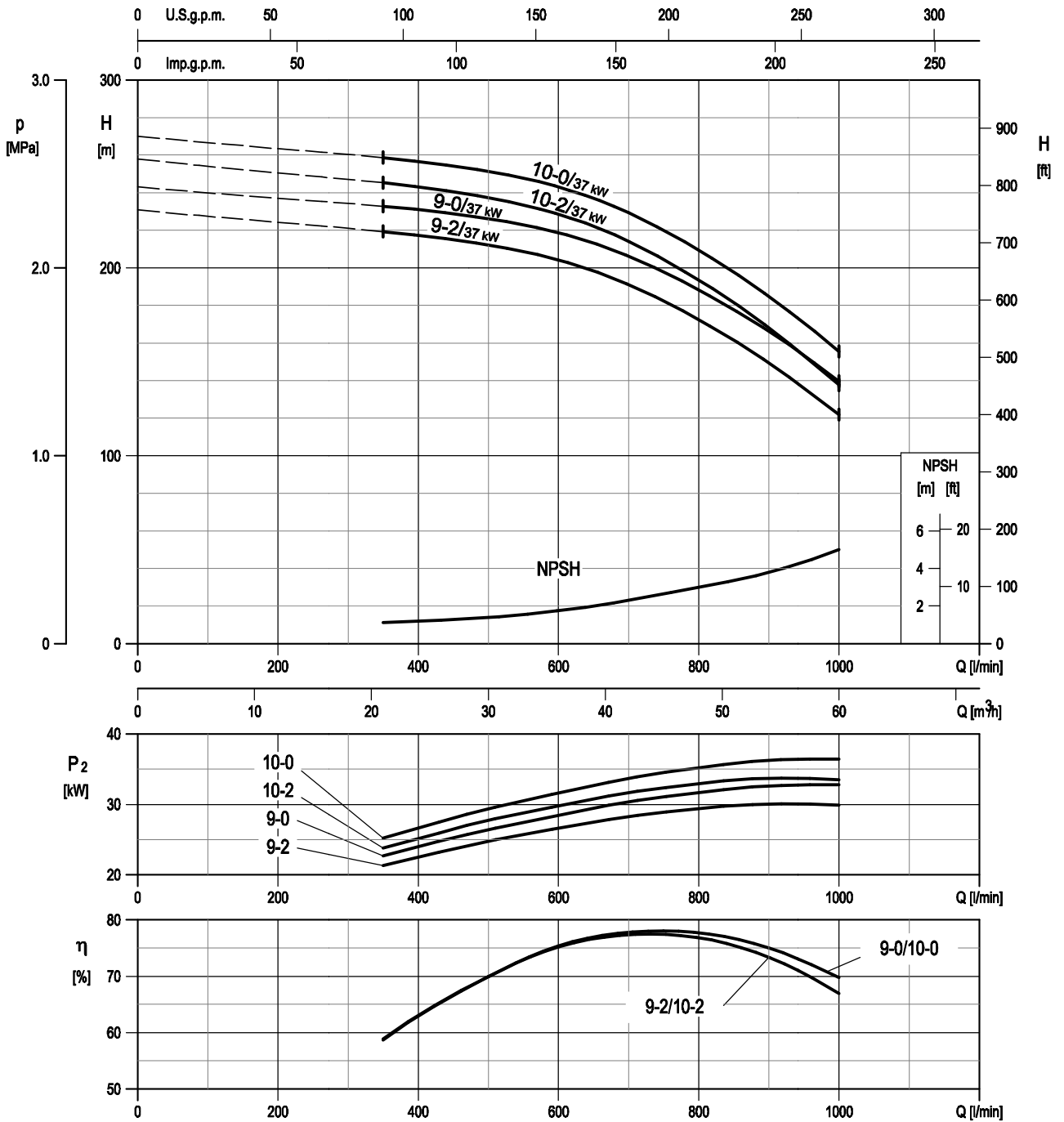

Rotation speed ≈ 2900 min⁻¹
Test standard: ISO 9906:2012 - Grade 3B

TECHNICAL DATA EVMG45

Dimensional sketch

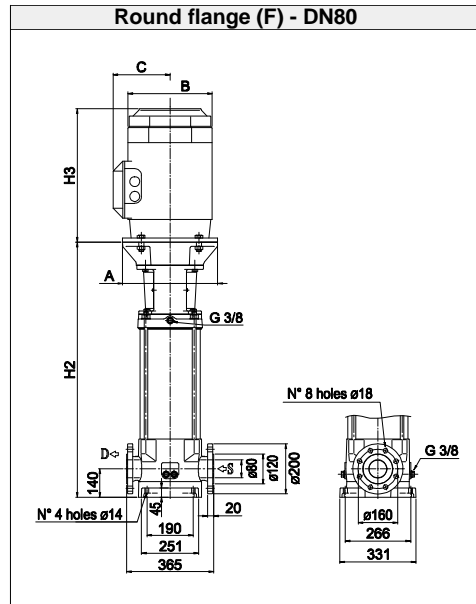

Dimensions [mm] and Weights [Kg]

Pump Type	Pmax [MPa]	kW	Size	Motor				Round flange (F)		
				A	3 -			H2	Weight Pump	Weight Pump + Motor
					B	C	H3			
EVMG45 1-1F5/3.0	1.6	3.0	100 L	160	196	155	306	525	71	93.8
EVMG45 1-0F5/4.0	1.6	4.0	112 M	160	196	155	306	525	73	95.8
EVMG45 2-2F5/5.5	1.6	5.5	132 S	300	225	160	328	618	81	119.6
EVMG45 2-0F5/7.5	1.6	7.5	132 S	300	225	160	350	618	81	121.4
EVMG45 3-2F5/11	1.6	11	160 M	350	248	194	476	821	99	161.5
EVMG45 3-0F5/11	1.6	11	160 M	350	248	194	476	821	99	161.5
EVMG45 4-2F5/15	2.5	15	160 M	350	317	238	498	893	108	196.9
EVMG45 4-0F5/15	2.5	15	160 M	350	317	238	498	893	108	196.9
EVMG45 5-2F5/18.5	2.5	18.5	160 L	350	317	238	542	965	128	232
EVMG45 5-0F5/18.5	2.5	18.5	160 L	350	317	238	542	965	128	232
EVMG45 6-2F5/22	2.5	22	180 M	350	360	268	577	1037	133	296
EVMG45 6-0F5/22	2.5	22	180 M	350	360	268	577	1037	133	296
EVMG45 7-2F5/30	2.5	30	200 L	400	399	300	658	1124	139	367
EVMG45 7-0F5/30	2.5	30	200 L	400	399	300	658	1124	139	367
EVMG45 8-2F5/30	2.5	30	200 L	400	399	300	658	1196	146	374
EVMG45 8-0F5/30	2.5	30	200 L	400	399	300	658	1196	146	374
EVMG45 9-2F5/30	2.5	30	200 L	400	399	300	658	1269	151	379
EVMG45 9-0F5/37	2.5	37	200 L	400	399	300	658	1269	151	393
EVMG45 10-2F5/37	3.0	37	200 L	400	399	300	658	1341	156	398
EVMG45 10-0F5/37	3.0	37	200 L	400	399	300	658	1341	156	398

1.6 MPa=16 bar ; 2.5 MPa=25 bar ; 3.0 MPa=30 bar

SECTIONAL VIEW
EVMG45

EVMG45

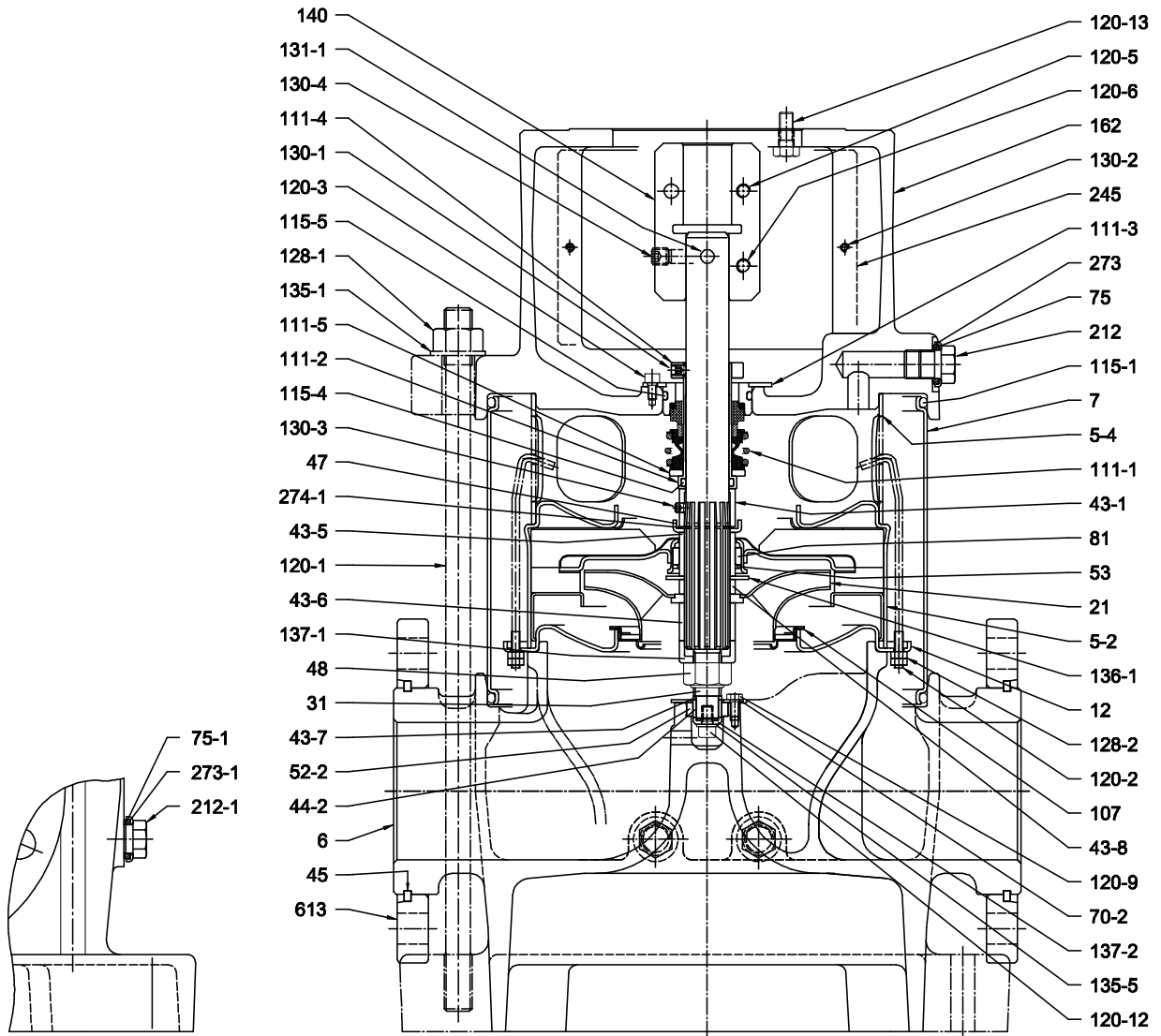

Pump without ball bearing

SECTIONAL VIEW EVMG45

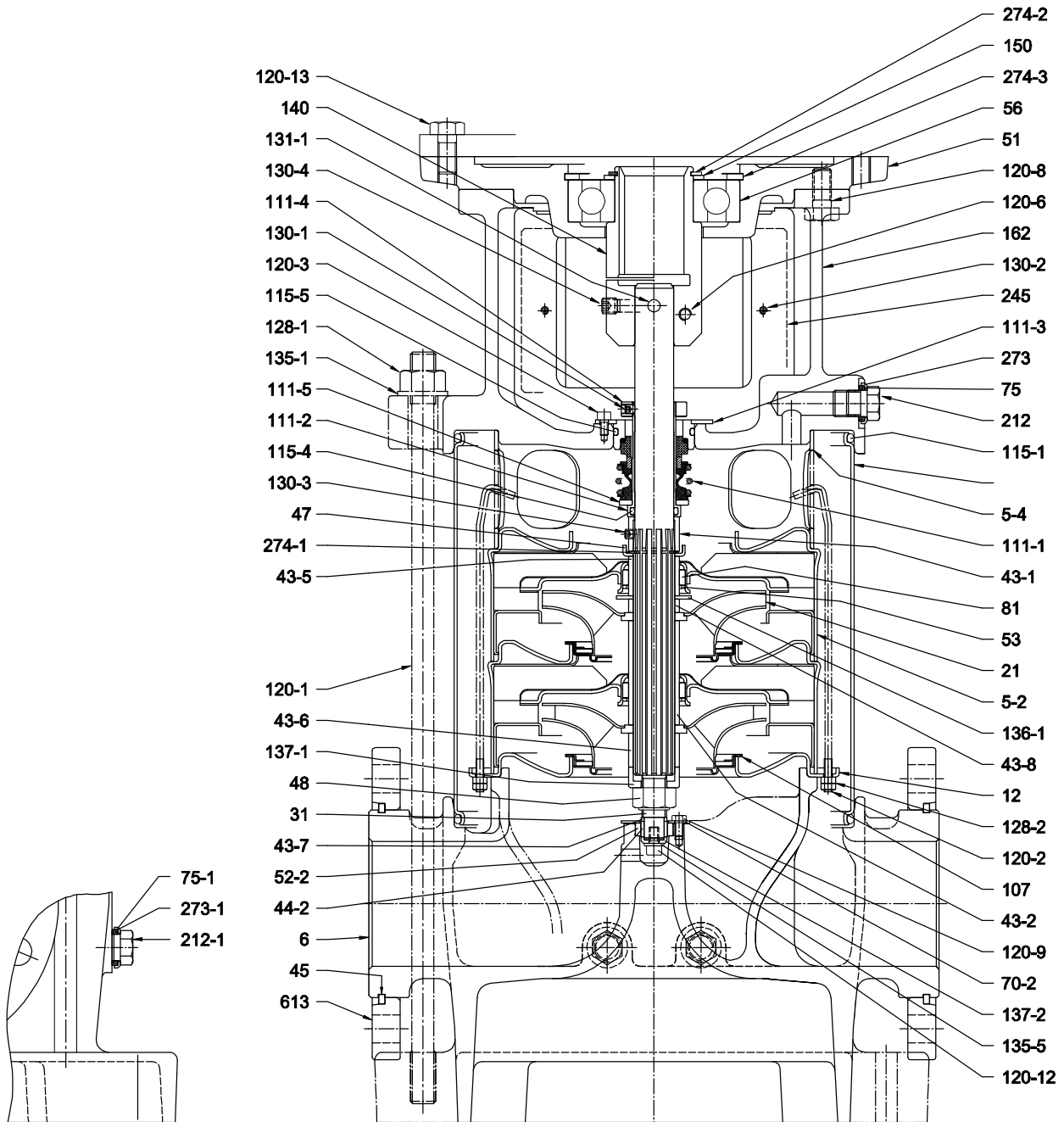

Pump with single ball bearing

EVMG45

SECTIONAL VIEW
EVMG45

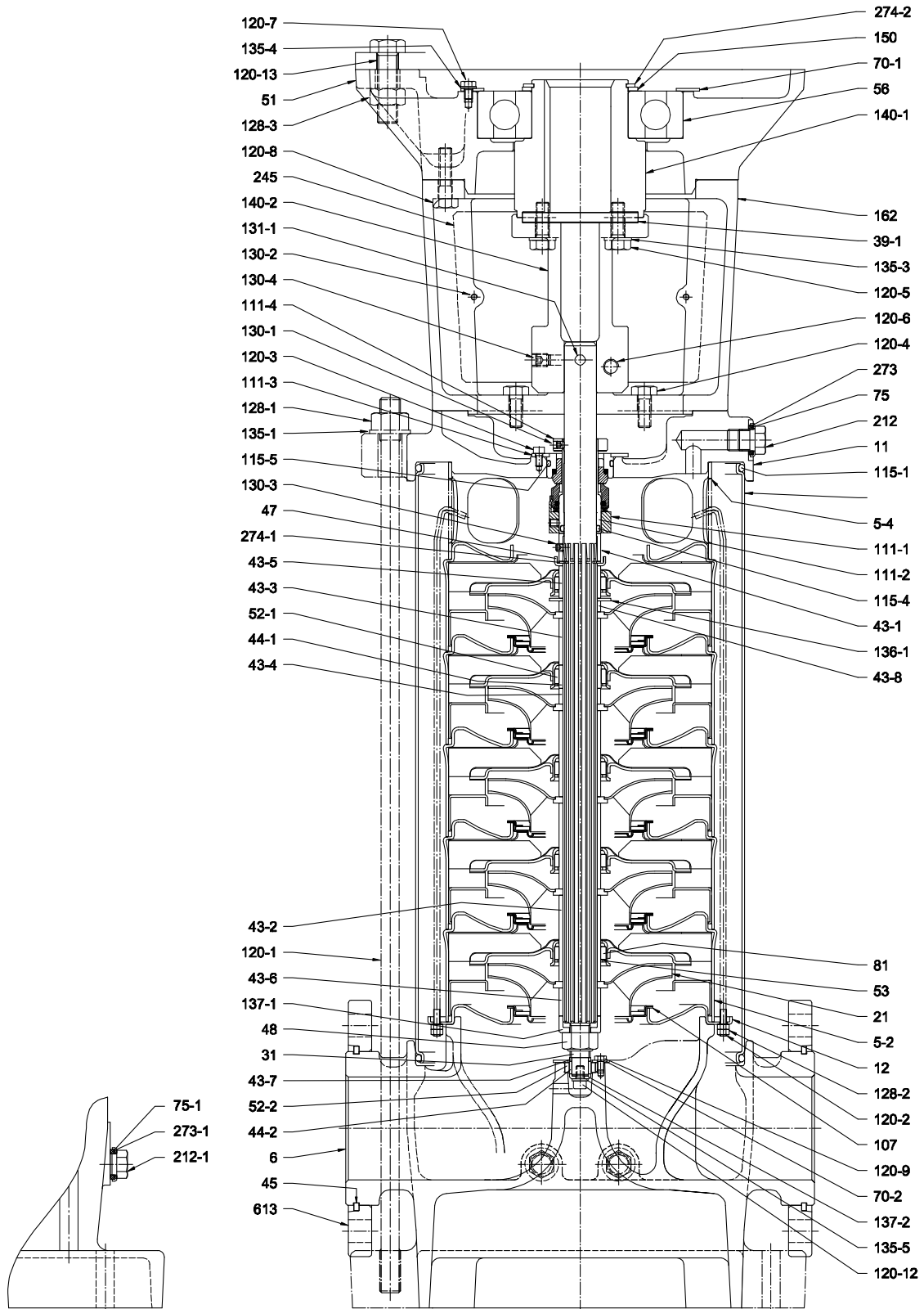

Pump with single ball bearing

SECTIONAL VIEW EVMG45

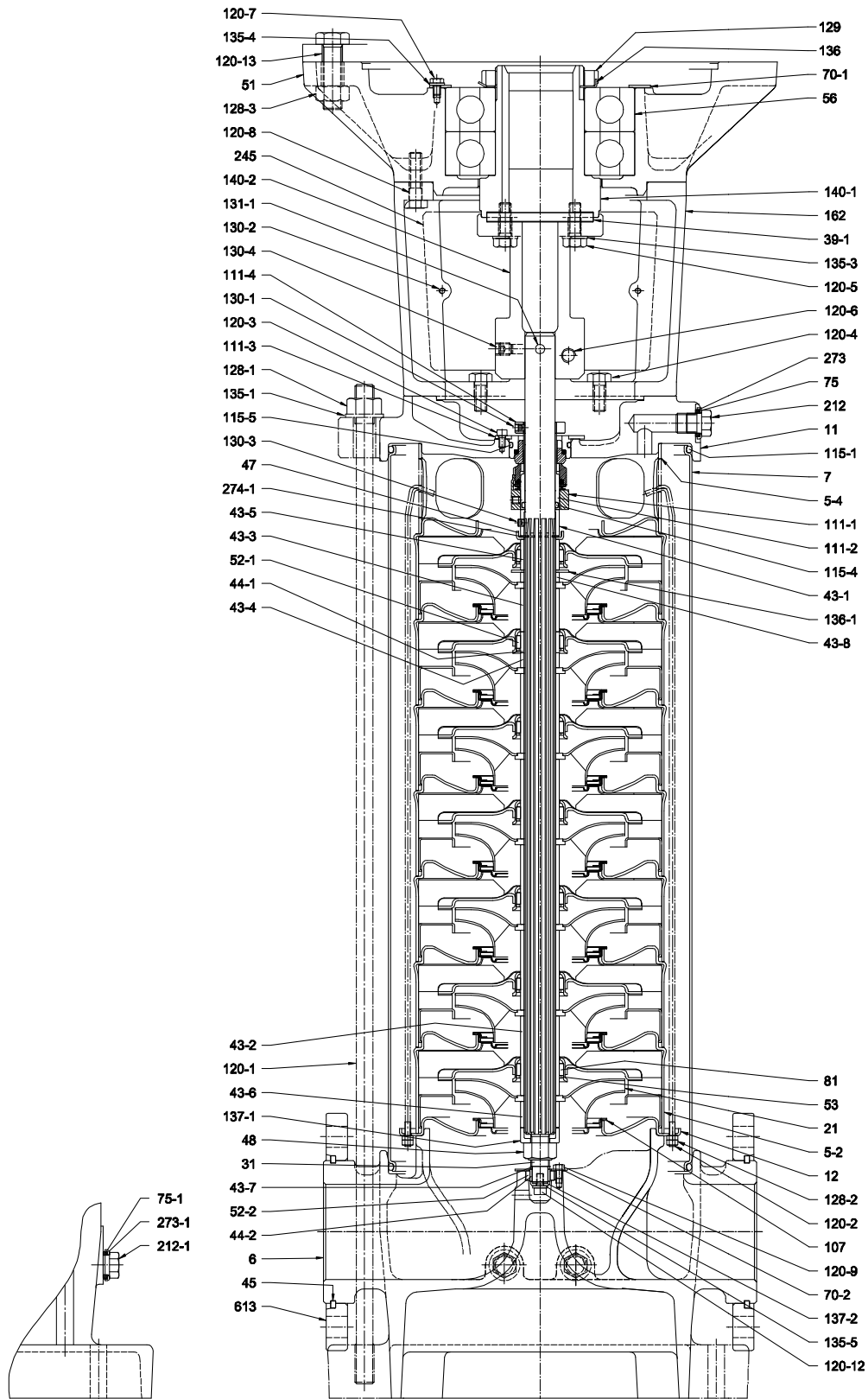

Pump with double ball bearing

360

EVMG45

SECTIONAL TABLE
EVMG45

N°	PART NAME	MATERIAL EVMG	DIMENSIONS	STANDARD
5-2	Intermediate casing	EN 1.4301 (AISI 304)		
5-4	Discharge casing	EN 1.4301 (AISI 304)		
6	Bottom casing	Cast iron EN G.JL 250 EN 1561		
7	Outer casing	EN 1.4301 (AISI 304)		
11	Casing cover	Cast iron EN G.JL 250 EN 1561		
12	Suction cover	EN 1.1301 (AISI304)		
21	Impeller			
21-1	Reduced impeller	EN 1.4301 (AISI 304)		
31	Shaft	EN 1.4401 (AISI 316)		
39-1	Key	Carbon steel	12x8x90	UNI 6604
43-1	Shaft sleeve (mechanical seal)	EN 1.4301 (AISI 304)		
43-2	Shaft sleeve (intermediate)	EN 1.4301 (AISI 304)		
43-3	Shaft sleeve (bearing)	EN 1.4301 (AISI 304)		
43-4	Shaft sleeve (adjustment)	EN 1.4301 (AISI 304)		
43-5	Shaft sleeve (last stage)	EN 1.4301 (AISI 304)		
43-6	Shaft sleeve (adjustment)	EN 1.4301 (AISI 304)		
43-7	Shaft sleeve	EN 1.4301 (AISI 304)		
43-8	Shaft sleeve (discharge-lower)	EN 1.4301 (AISI 304)		
44-1	Shaft sleeve bearing	Tungsten carbide		
44-2	Bearing sleeve (bottom bearing)	Tungsten carbide		
45	Flange holder	EN 1.402 (AISI 420)		
47	Ring holder	EN 1.4301 (AISI 304)		
48	Impeller nut	A2-70 UNI 7323 with inox insert	M16	
51	Motor adapter	Cast iron EN-G.JL-200-EN 1561		
52-1	Bearing	Tungsten carbide		
52-2	Bearing	Tungsten carbide		
53	Bush holder	EN 1.4301 (AISI 304)		
56	Ball bearing	see table page 363		
70-1	Ring for bearing	EN 1.4301 (AISI 304)		
70-2	Ring for bearing	EN 1.4301 (AISI 304)		
75	O-Ring (plug)	EPDM		
75-1	O-Ring (plug)	EPDM		
81	Bush	PTFE		
107	Liner ring	PTFE /EN 1.4401 (AISI316)		
111-1	Mechanical seal	Silicon carbide /Carbon/FPM		
111-2	Mechanical seal cartridge	EN 1.4301 (AISI 304)		
111-3	Mechanical seal seat	EN 1.4301 (AISI 304)		
111-4	Seal holder	Brass OT 58 UNI 5705		
111-5	Adjusting ring	EN 1.4301 (AISI 304)		
115-1	O-Ring (outer casing)	EPDM	D.240.66x5.34	
115-4	O-Ring (cartridge sleeve)	EPDM	D.24.99x3.53	
115-5	O-Ring (seal cover)	EPDM	D.44.04x3.53	
120-1	Tie Rod	Galvanized steel 6.8 strenght class ISO 898/1		

SECTIONAL TABLE EVMG45

N°	PART NAME	MATERIAL EVMG	DIMENSIONS	STANDARD	
120-2	Tie Rod	EN 1.4301 (AISI 304)			
120-3	Screw	A2-70 UNI 7323	M5x10	UNI 5931	
120-4	Screw	Galvanized steel 8.8 strenght class ISO 898/1	M10x25	UNI 5739	
120-5	Screw for coupling	EVM45 1-0 and 1-1 EVM45 3 to 10	Galvanized steel 8.8 strenght class ISO 898/1	M8x20	UNI 5931
				M10x30	UNI 5739
120-6	Screw for coupling	EVM45 1 to 2 EVM45 3 to 10	Galvanized steel 8.8 strenght class ISO 898/1	M8x20	UNI 5931
				M12x30	UNI 5931
120-7	Screw	Galvanized steel 8.8 strenght class ISO 898/1	M6x10	UNI 5739	
120-8	Screw	EVM45 2-0 and 2-2 EVM45 3 to 10	Galvanized steel 8.8 strenght class ISO 898/1	M12x25	UNI 5739
				M10x30	UNI 5739
120-9	Screw	EVML EVM, EVMG	EN 1.4301 (AISI 304)	M5x8	UNI 5737
					UNI 5739
120-12	Screw	EN 1.4301 (AISI 304)	M6x20	UNI 5931	
120-13	Screw	EVM45 1-0, 1-1 EVM45 2-0, 2-2 EVM45 9-0, 10-0, 10-2 EVM45 9-0, 10-0, 10-2 EVM45 3-0 to 9-2	Galvanized steel 8.8 strenght class ISO 898/1	M8x20	UNI 5739
				M12x30	UNI 5739
				M6x10	UNI 5739
				M16x55	UNI 5737
				M16x65	UNI 5739
128-1	Nut for tie rod	Galvanized steel	M16	UNI 5588	
128-2	Nut	Carbon steel	M5	UNI 5588	
128-3	Nut	Galvanized steel	M16	UNI 5588	
129	Lock nut	Carbon steel	M75x2		
130-1	Set screw	A2- 70 UNI 7323	M6x8	UNI 5923	
130-2	Screw for coupling guard	A2-70 UNI 7323	M5x6	UNI 7687	
130-3	Set screw	A2- 70 UNI 7323	M6x6	UNI 5923	
130-4	Set screw	Carbon steel	M10x10	UNI 5923	
131-1	Pin for shaft	Carbon steel			
131-2	Elastic pin	-	6x25	UNI 6873	
135-1	Washer	Galvanized steel	17x30x3	UNI 6592	
135-3	Washer	Galvanized steel	10.5x17.5x2.2	UNI 1751	
135-4	Washer	Plated carbon steel	6,4	UNI 1751	
135-5	Washer	EN 1.4301 (AISI 304)			
136	Bearing washer	Carbon steel			
136-1	Stopper ring	EN 1.4301 (AISI 304)			
137-1	Impeller spacer	EN 1.4301 (AISI 304)			
137-2	Shaft spacer	EN 1.4301 (AISI 304)			
140	Coupling	Brass OT 58 UNI 5705			
140-1	Motor coupling	Carbon steel			
140-2	Coupling (pump side)	Carbon steel			
150	Spacer	Carbon steel			
160	Base	-			
162	Mator bracket	Cast iron EN-GJL-200 EN1561			
212	Plug	EN 1.4301 (AISI 304)			
212-1	Plug	EN 1.4301 (AISI 304)			
245	Coupling guard	EN 1.4301 (AISI 304)			
273	Plug washer	EN 1.4301 (AISI 304)			
273-1	Plug washer	EN 1.4301 (AISI 304)			
274-1	C-type snap ring	EN 1.4301 (AISI 304)	D.26	UNI 7435	
274-2	C-Typr snap ring	EVM45 2-0, 2-2 EVM45 3 to 5 EVM45 6-0 and 6-2	Carbon steel TC80	D.50	UNI 7435
				D.65	UNI 7435
				D.75	UNI 7535
274-3	C-Typr snap ring	Carbon steel TC80	D.110	UNI 7437	
613	Flange	Carbon steel			

QUANTITY FOR MODEL
EVMG45

Pump Type	N°																														
	5-2	11	21	21-1	39-1	43-2	43-3	43-4	44-1	51	52-1	53	56	70-1	81	107	120-4	120-5	120-7	120-8	128-3	129	135-3	135-4	136	140	140-1	140-2	150	274-2	274-3
EVMG45 1-1F5/3.0	1	/	/	1	/	/	/	/	/	/	/	1	/	/	1	1	/	2	/	/	/	/	/	/	1	1	/	/	/	/	/
EVMG45 1-0F5/4.0	1	/	1	/	/	/	/	/	/	/	/	1	/	/	1	1	/	2	/	/	/	/	/	/	1	1	/	/	/	/	/
EVMG45 2-2F5/5.5	2	/	/	2	/	1	/	/	/	1	/	2	1	/	2	2	/	/	/	4	/	/	/	/	1	1	/	/	1	1	1
EVMG45 2-0F5/7.5	2	/	2	/	1	/	/	/	1	/	2	1	/	2	2	/	/	/	4	/	/	/	/	/	1	1	/	/	1	1	1
EVMG45 3-2F5/11	3	1	1	2	1	2	/	/	/	1	/	3	1	1	3	3	4	4	3	4	4	4	/	4	3	/	/	1	1	1	1
EVMG45 3-0F5/11	3	1	3	/	1	2	/	/	/	1	/	3	1	1	3	3	4	4	3	4	4	4	/	4	3	/	/	1	1	1	1
EVMG45 4-2F5/15	4	1	2	2	1	2	1	1	1	1	1	4	1	1	3	4	4	4	3	4	4	4	/	4	3	/	/	1	1	1	1
EVMG45 4-0F5/15	4	1	4	/	1	2	1	1	1	1	1	4	1	1	3	4	4	4	3	4	4	4	/	4	3	/	/	1	1	1	1
EVMG45 5-2F5/18.5	5	1	3	2	1	3	1	1	1	1	1	5	1	1	4	5	4	4	3	4	4	4	/	4	3	/	/	1	1	1	1
EVMG45 5-0F5/18.5	5	1	5	/	1	3	1	1	1	1	1	5	1	1	4	5	4	4	3	4	4	4	/	4	3	/	/	1	1	1	1
EVMG45 6-2F5/22	6	1	4	2	1	4	1	1	1	1	1	6	1	1	5	6	4	4	3	4	4	4	/	4	3	/	/	1	1	1	1
EVMG45 6-0F5/22	6	1	6	/	1	4	1	1	1	1	1	6	1	1	5	6	4	4	3	4	4	4	/	4	3	/	/	1	1	1	1
EVMG45 7-2F5/30	7	1	5	2	1	5	1	1	1	1	1	7	1	1	6	7	4	4	3	4	4	4	1	4	3	1	/	1	1	1	1
EVMG45 7-0F5/30	7	1	7	/	1	5	1	1	1	1	1	7	1	1	6	7	4	4	3	4	4	4	1	4	3	1	/	1	1	1	1
EVMG45 8-2F5/30	8	1	6	2	1	6	1	1	1	1	1	8	1	1	7	8	4	4	3	4	4	4	1	4	3	1	/	1	1	1	1
EVMG45 8-0F5/30	8	1	8	/	1	6	1	1	1	1	1	8	1	1	7	8	4	4	3	4	4	4	1	4	3	1	/	1	1	1	1
EVMG45 9-2F5/30	9	1	7	2	1	7	1	1	1	1	1	9	1	1	8	9	4	4	3	4	4	4	1	4	3	1	/	1	1	1	1
EVMG45 9-0F5/37	9	1	9	/	1	7	1	1	1	1	1	9	1	1	8	9	4	4	3	4	4	4	1	4	3	1	/	1	1	1	1
EVMG45 10-2F5/37	10	1	8	2	1	8	1	1	1	1	1	10	1	1	9	10	4	4	3	4	4	4	1	4	3	1	/	1	1	1	1
EVMG45 10-0F5/37	10	1	10	/	1	8	1	1	1	1	1	10	1	1	9	10	4	4	3	4	4	4	1	4	3	1	/	1	1	1	1

EVMG45

BEARINGS
EVMG45

Pump Type	N° 56
EVMG45 1-1F5/3.0	/
EVMG45 1-0F5/4.0	/
EVMG45 2-2F5/5.5	6310 ZZ C3
EVMG45 2-0F5/7.5	6310 ZZ C3
EVMG45 3-2F5/11	6313 ZZ C3
EVMG45 3-0F5/11	6313 ZZ C3
EVMG45 4-2F5/15	6313 ZZ C3
EVMG45 4-0F5/15	6313 ZZ C3
EVMG45 5-2F5/18.5	6313 ZZ C3
EVMG45 5-0F5/18.5	6313 ZZ C3
EVMG45 6-2F5/22	6315 ZZ C3
EVMG45 6-0F5/22	6315 ZZ C3
EVMG45 7-2F5/30	6315 ZZDT C3 *
EVMG45 7-0F5/30	6315 ZZDT C3 *
EVMG45 8-2F5/30	6315 ZZDT C3 *
EVMG45 8-0F5/30	6315 ZZDT C3 *
EVMG45 9-2F5/30	6315 ZZDT C3 *
EVMG45 9-0F5/37	6315 ZZDT C3 *
EVMG45 10-2F5/37	6315 ZZDT C3 *
EVMG45 10-0F5/37	6315 ZZDT C3 *

*DT=Two single row deep groove ball bearings matched for paired mounting in a tandem arrangement.

PERFORMANCE CURVE EVM(L)64

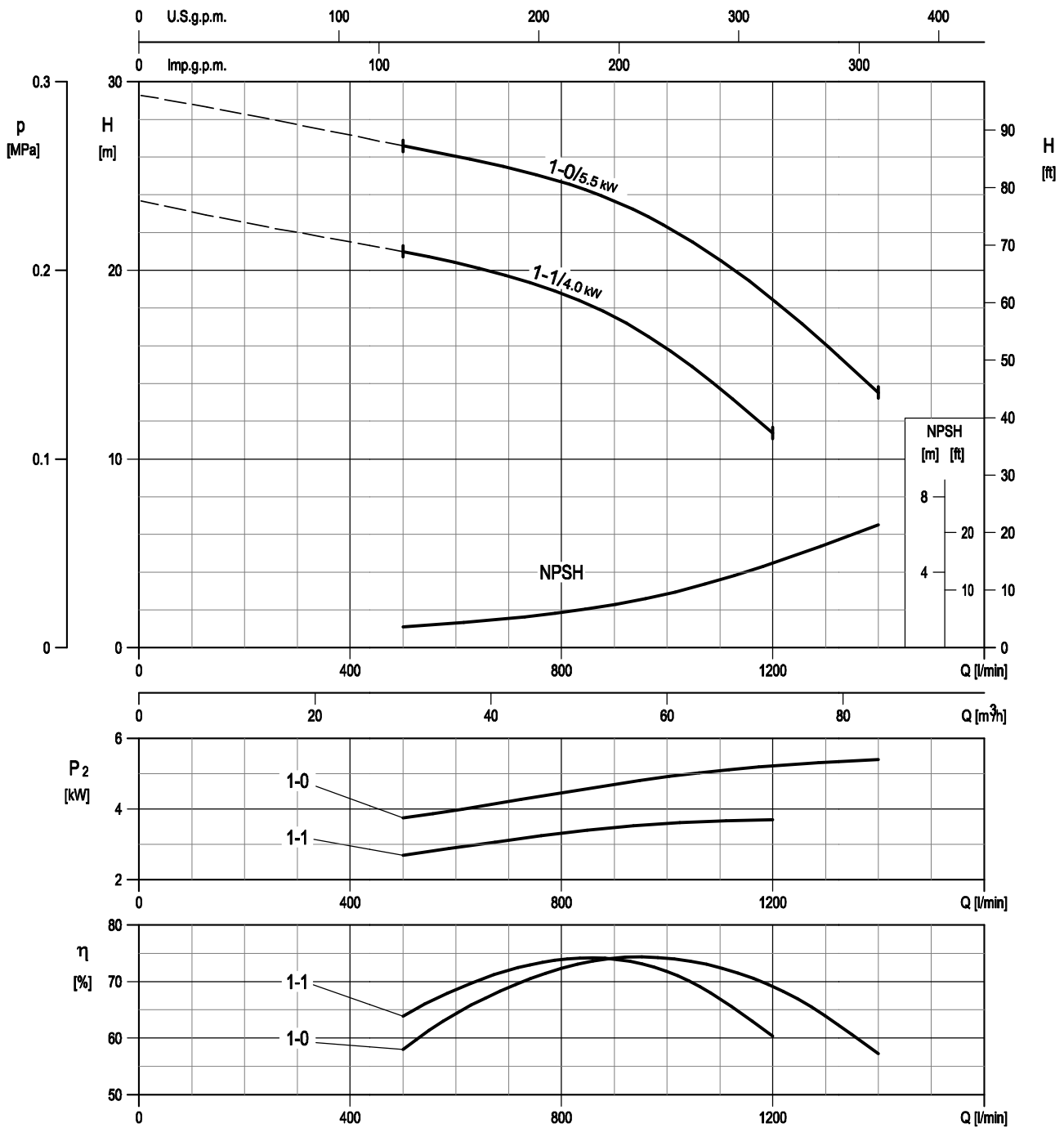

Rotation speed $\approx 2900 \text{ min}^{-1}$
 Test standard: ISO 9906:2012 - Grade 3B

PERFORMANCE CURVE
EVM(L)64

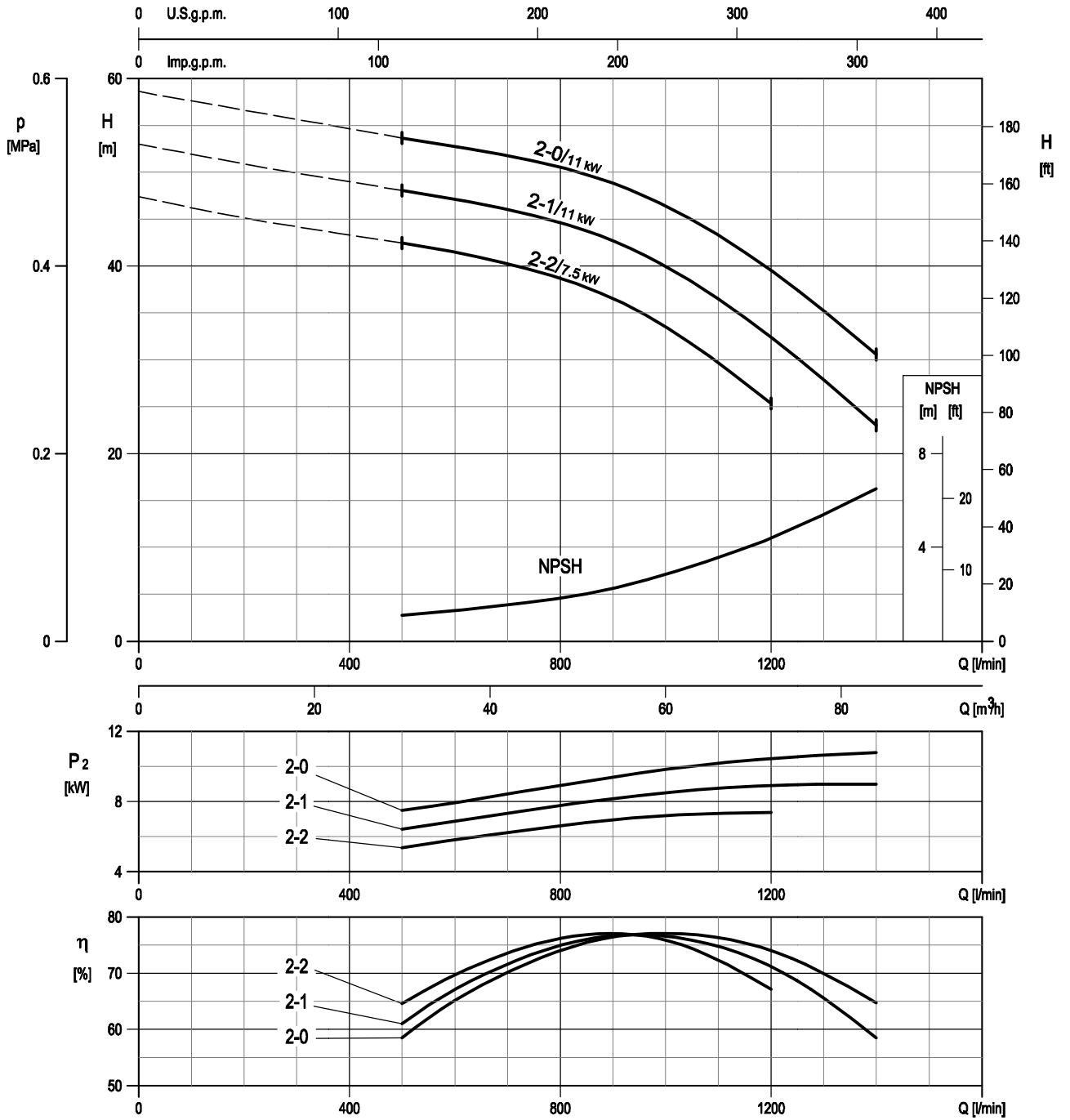

Rotation speed ≈ 2900 min⁻¹
Test standard: ISO 9906:2012 - Grade 3B

PERFORMANCE CURVE EVM(L)64

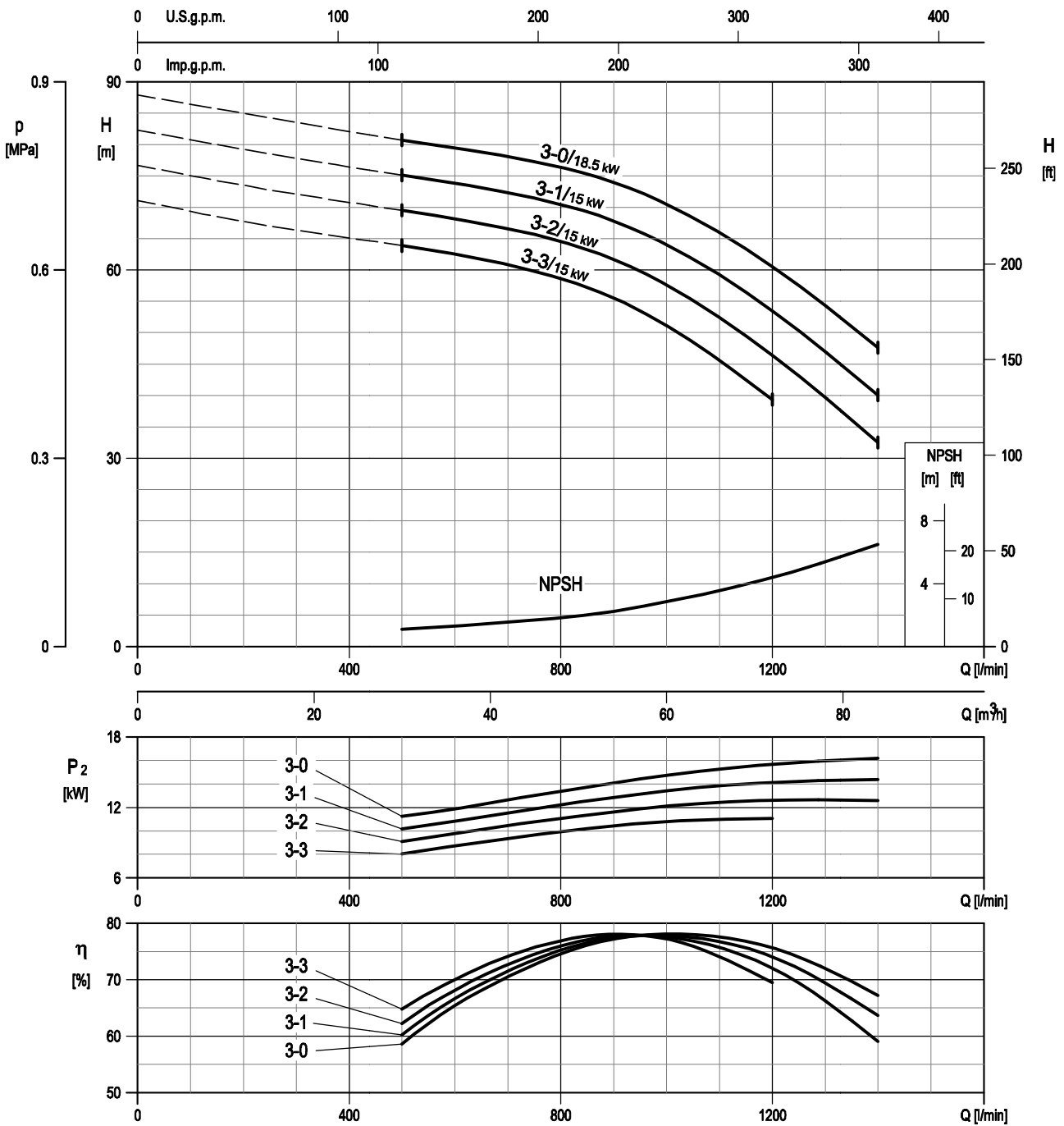

Rotation speed $\approx 2900 \text{ min}^{-1}$
 Test standard: ISO 9906:2012 - Grade 3B

EVM(L)64

PERFORMANCE CURVE
EVM(L)64

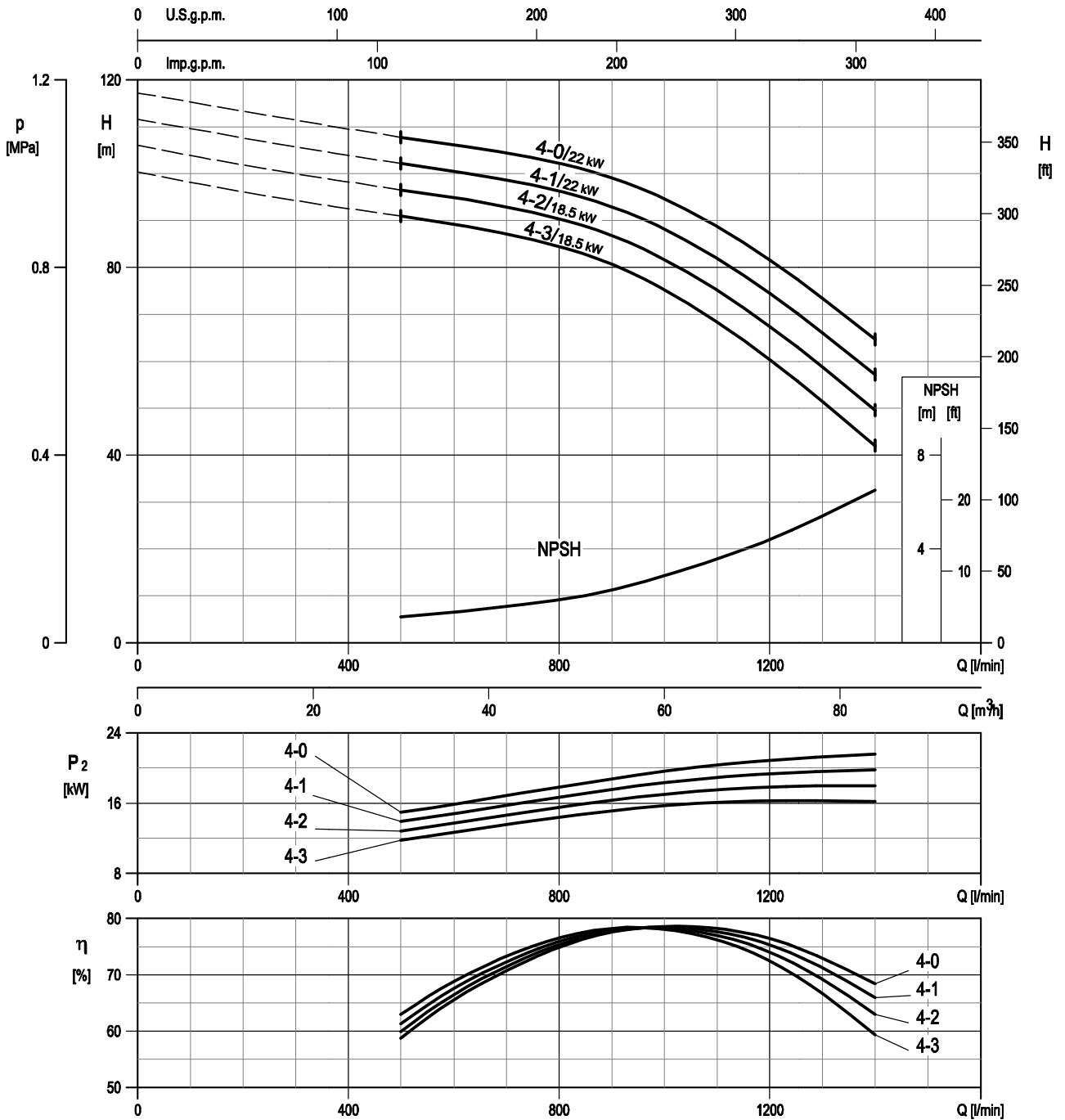

Rotation speed $\approx 2900 \text{ min}^{-1}$
Test standard: ISO 9906:2012 - Grade 3B

PERFORMANCE CURVE EVM(L)64

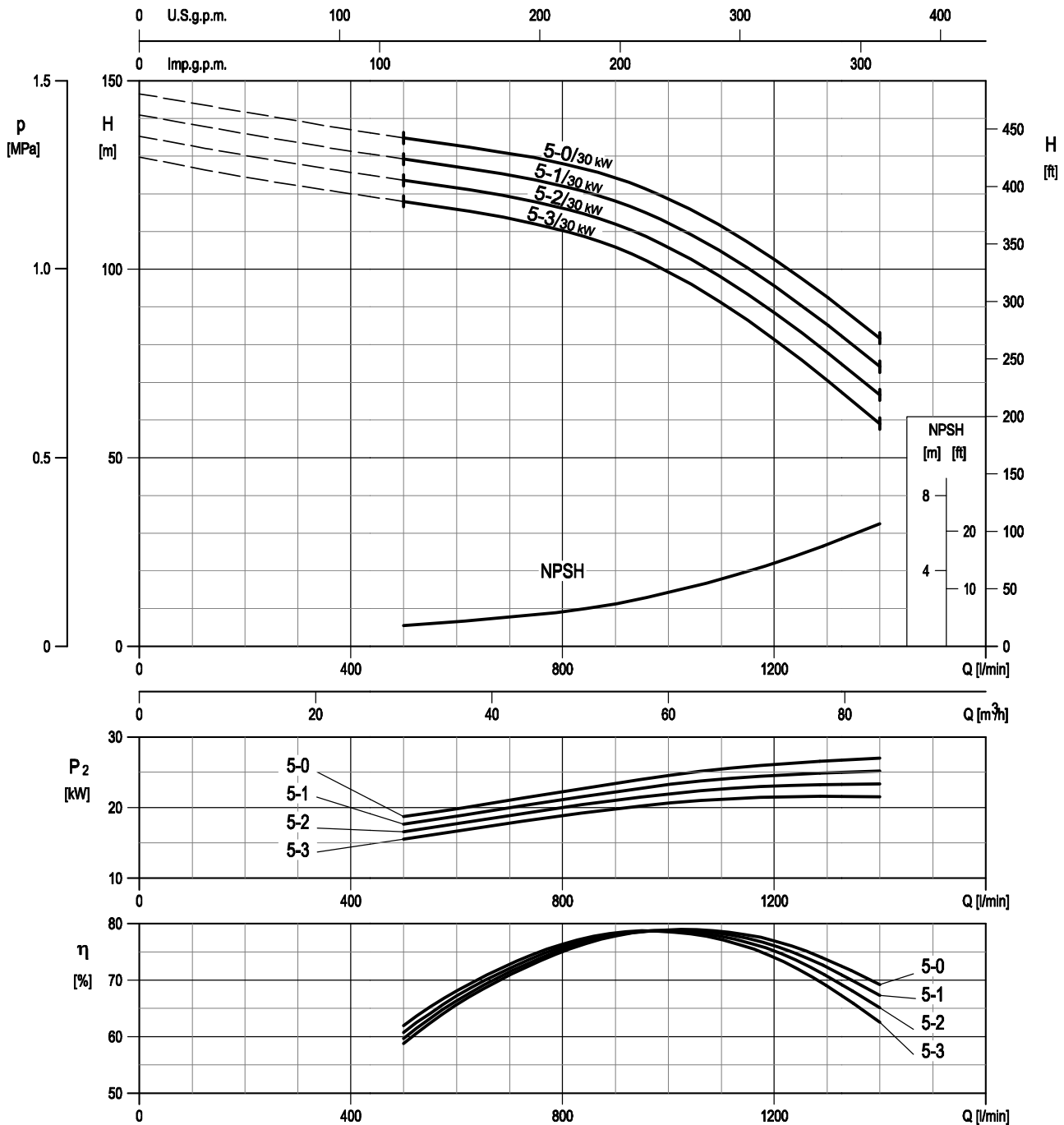

Rotation speed $\approx 2900 \text{ min}^{-1}$
 Test standard: ISO 9906:2012 - Grade 3B

EVM(L)64

PERFORMANCE CURVE
EVM(L)64

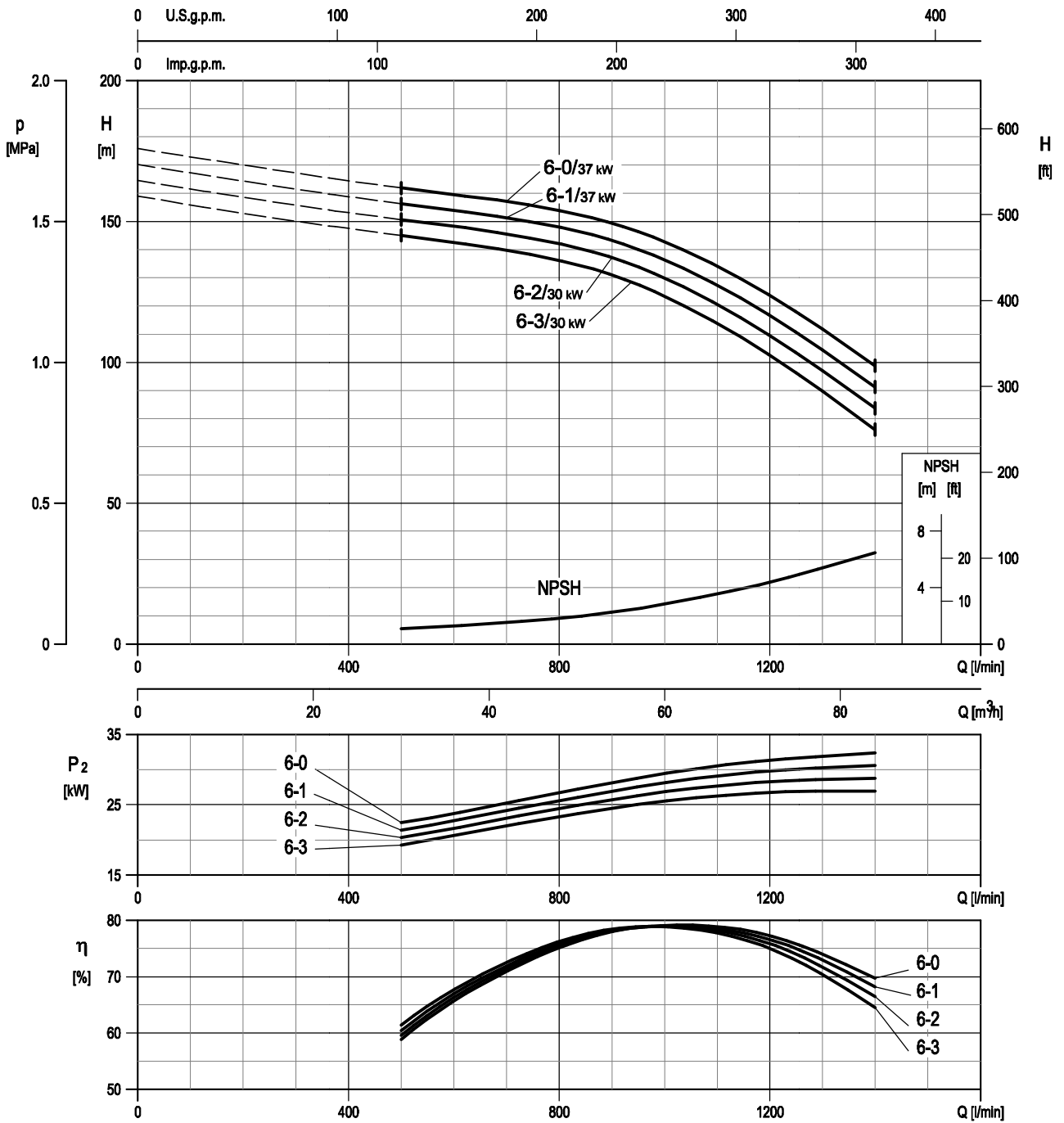

Rotation speed $\approx 2900 \text{ min}^{-1}$
Test standard: ISO 9906:2012 - Grade 3B

PERFORMANCE CURVE EVM(L)64

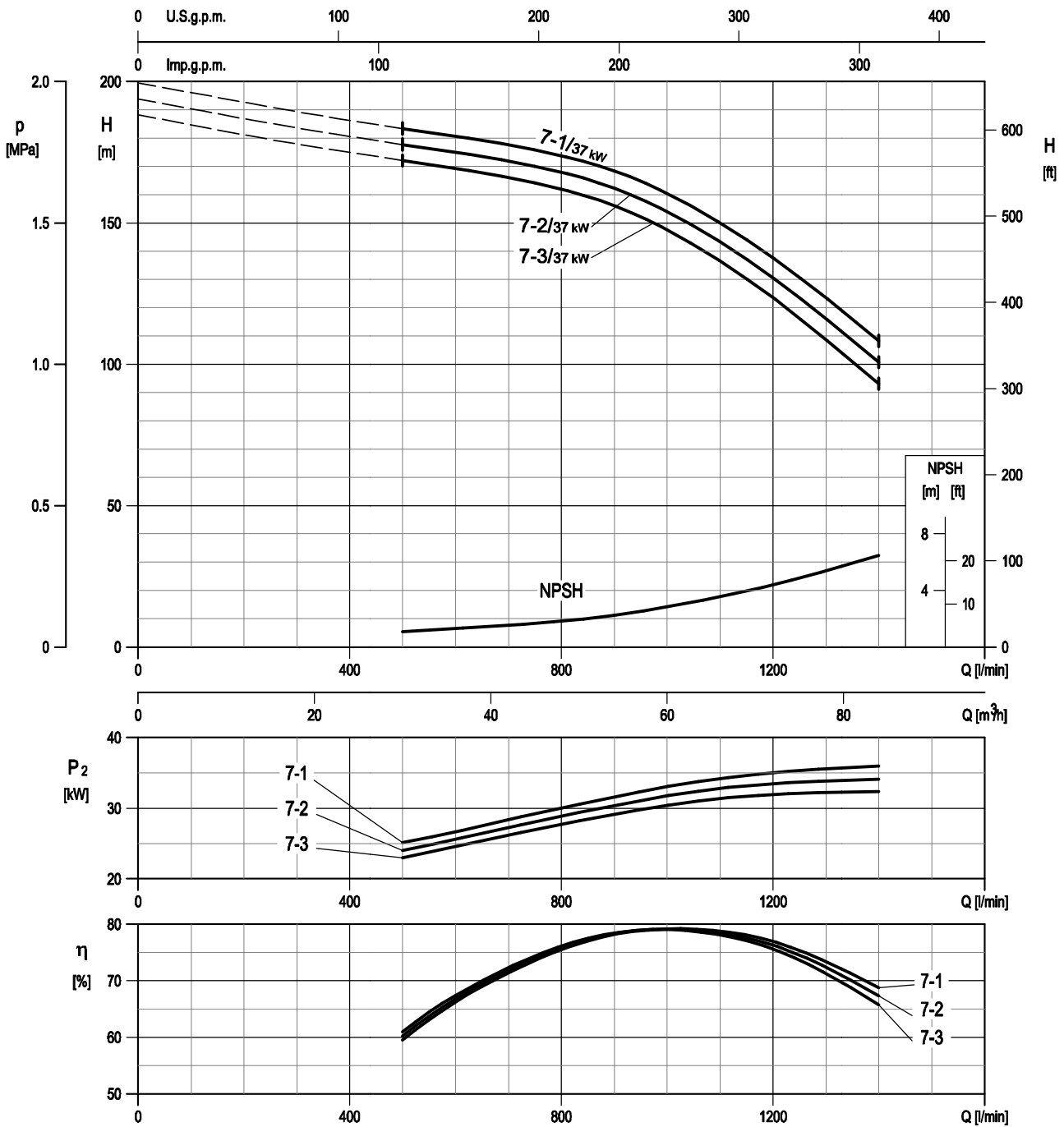

Rotation speed $\approx 2900 \text{ min}^{-1}$
Test standard: ISO 9906:2012 - Grade 3B

EVM(L)64

TECHNICAL DATA
EVM(L)64

Dimensional sketch

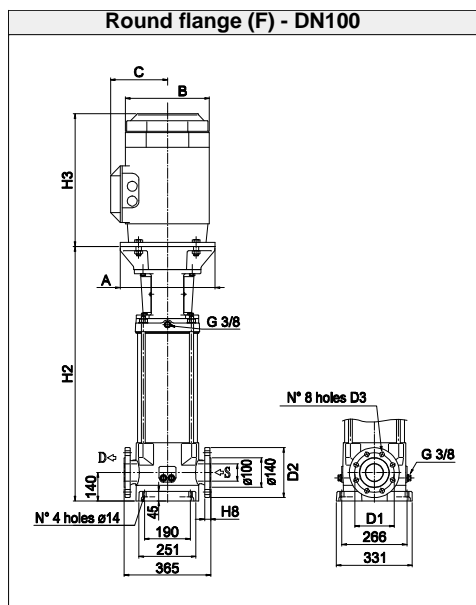

Dimensions [mm] and Weights [Kg]

Pump Type	Pmax [MPa]	kW	Motor				Round flange (F)						Weight Pump	Weight Pump + Motor
			Size	A	3 ~			H2	D1	D2	D3	H8		
EVM(L)64 1-1F5/4.0	1.6	4.0	112 M	160	196	155	306	525	ø180	ø220	ø18	20	70.4	93.2
EVM(L)64 1-0F5/5.5	1.6	5.5	132 S	300	225	160	328	546	ø180	ø220	ø18	20	77	115.6
EVM(L)64 2-2F5/7.5	1.6	7.5	132 S	300	225	160	350	618	ø180	ø220	ø18	20	81.4	121.8
EVM(L)64 2-1F5/11	1.6	11	160 M	350	248	194	476	749	ø180	ø220	ø18	20	93.5	156
EVM(L)64 2-0F5/11	1.6	11	160 M	350	248	194	476	749	ø180	ø220	ø18	20	93.5	156
EVM(L)64 3-3F5/15	1.6	15	160 M	350	317	238	498	821	ø180	ø220	ø18	20	99	187.9
EVM(L)64 3-2F5/15	1.6	15	160 M	350	317	238	498	821	ø180	ø220	ø18	20	99	187.9
EVM(L)64 3-1F5/15	1.6	15	160 M	350	317	238	498	821	ø180	ø220	ø18	20	99	187.9
EVM(L)64 3-0F5/18.5	1.6	18.5	160 L	350	317	238	542	821	ø180	ø220	ø18	20	99	203
EVM(L)64 4-3F5/18.5	1.6	18.5	160 L	350	317	238	542	893	ø180	ø220	ø18	20	108	212
EVM(L)64 4-2F5/18.5	1.6	18.5	160 L	350	317	238	542	893	ø180	ø220	ø18	20	108	212
EVM(L)64 4-1F5/22	1.6	22	180 M	350	360	268	577	893	ø180	ø220	ø18	20	116	279
EVM(L)64 4-0F5/22	1.6	22	180 M	350	360	268	577	893	ø180	ø220	ø18	20	116	279
EVM(L)64 5-3F5/30	1.6	30	200 L	400	399	300	658	980	ø180	ø220	ø18	20	128	356
EVM(L)64 5-2F5/30	1.6	30	200 L	400	399	300	658	980	ø180	ø220	ø18	20	128	356
EVM(L)64 5-1F5/30	1.6	30	200 L	400	399	300	658	980	ø180	ø220	ø18	20	128	356
EVM(L)64 5-0F5/30	1.6	30	200 L	400	399	300	658	980	ø180	ø220	ø18	20	128	356
EVM(L)64 6-3F5/30	1.6	30	200 L	400	399	300	658	1052	ø180	ø220	ø18	20	136	364
EVM(L)64 6-2F5/30	2.5	30	200 L	400	399	300	658	1052	ø190	ø235	ø22	26	136	364
EVM(L)64 6-1F5/37	2.5	37	200 L	400	399	300	658	1052	ø190	ø235	ø22	26	136	378
EVM(L)64 6-0F5/37	2.5	37	200 L	400	399	300	658	1052	ø190	ø235	ø22	26	136	378
EVM(L)64 7-3F5/37	2.5	37	200 L	400	399	300	658	1124	ø190	ø235	ø22	26	139	381
EVM(L)64 7-2F5/37	2.5	37	200 L	400	399	300	658	1124	ø190	ø235	ø22	26	139	381
EVM(L)64 7-1F5/37	2.5	37	200 L	400	399	300	658	1124	ø190	ø235	ø22	26	139	381

1.6 MPa=16 bar ; 2.5 MPa=25 bar

SECTIONAL VIEW EVM(L)64

EVM(L)64

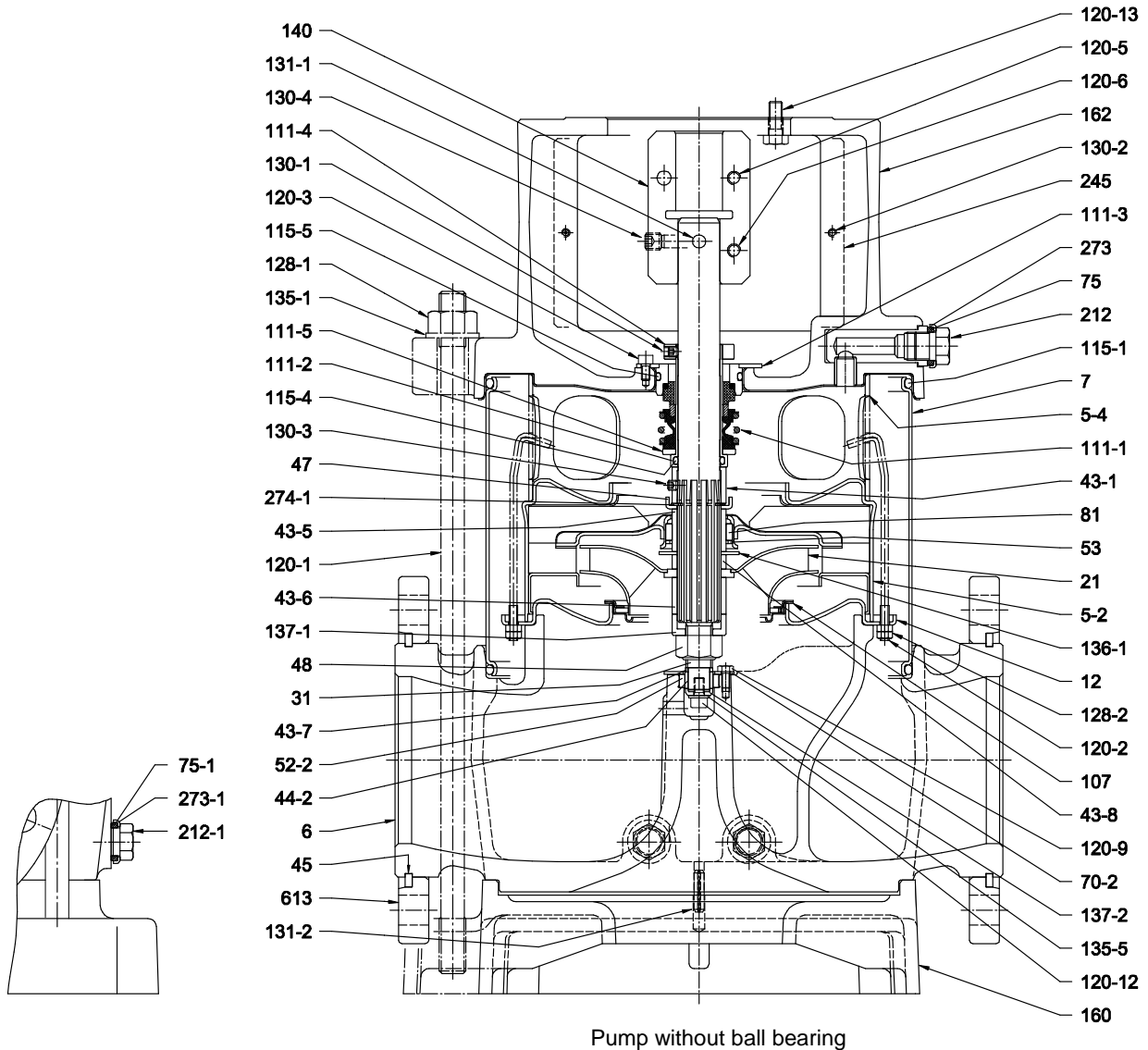

SECTIONAL VIEW
EVM(L)64

EVM(L)64

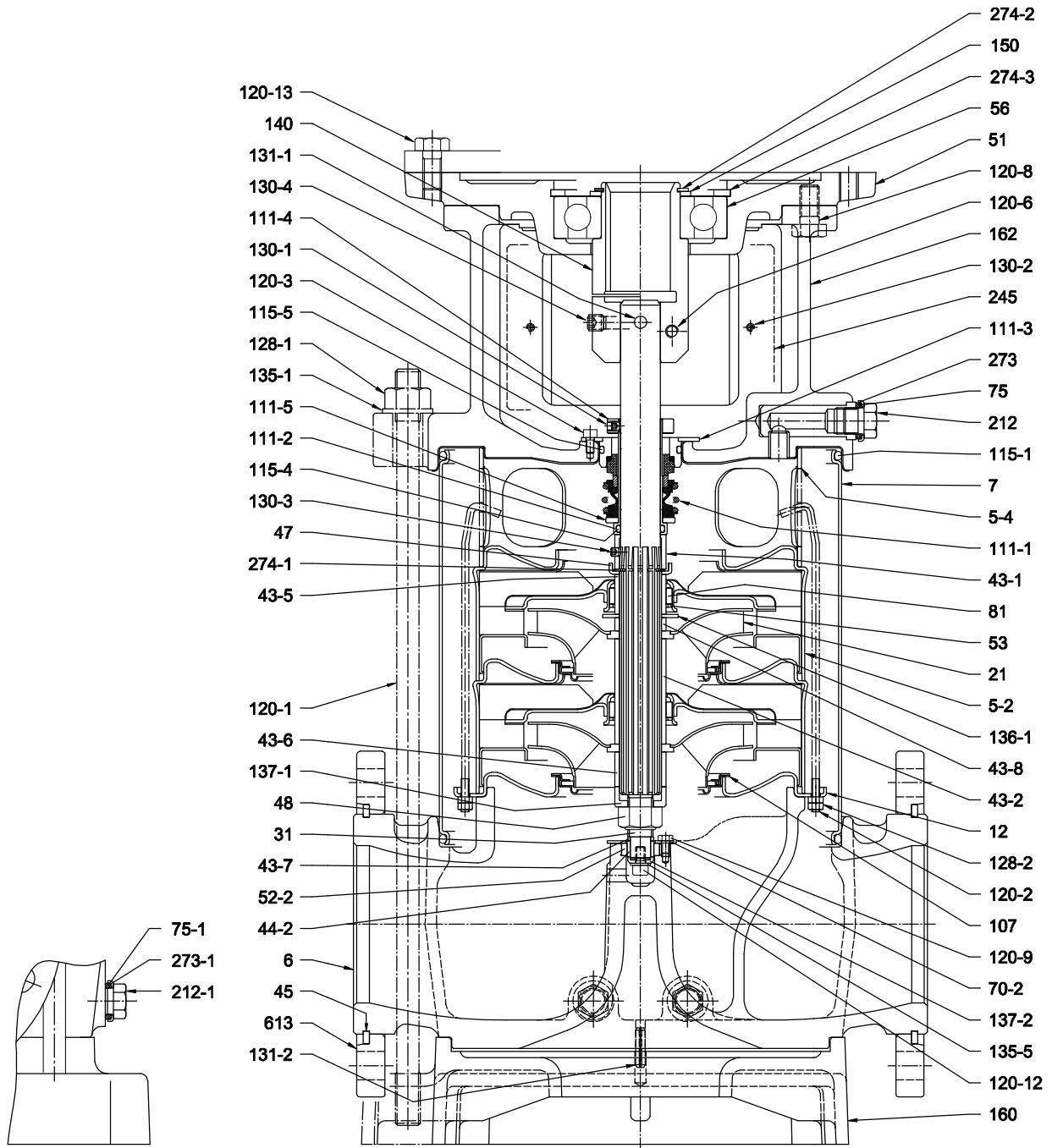

Pump with single ball bearing

SECTIONAL VIEW EVM(L)64

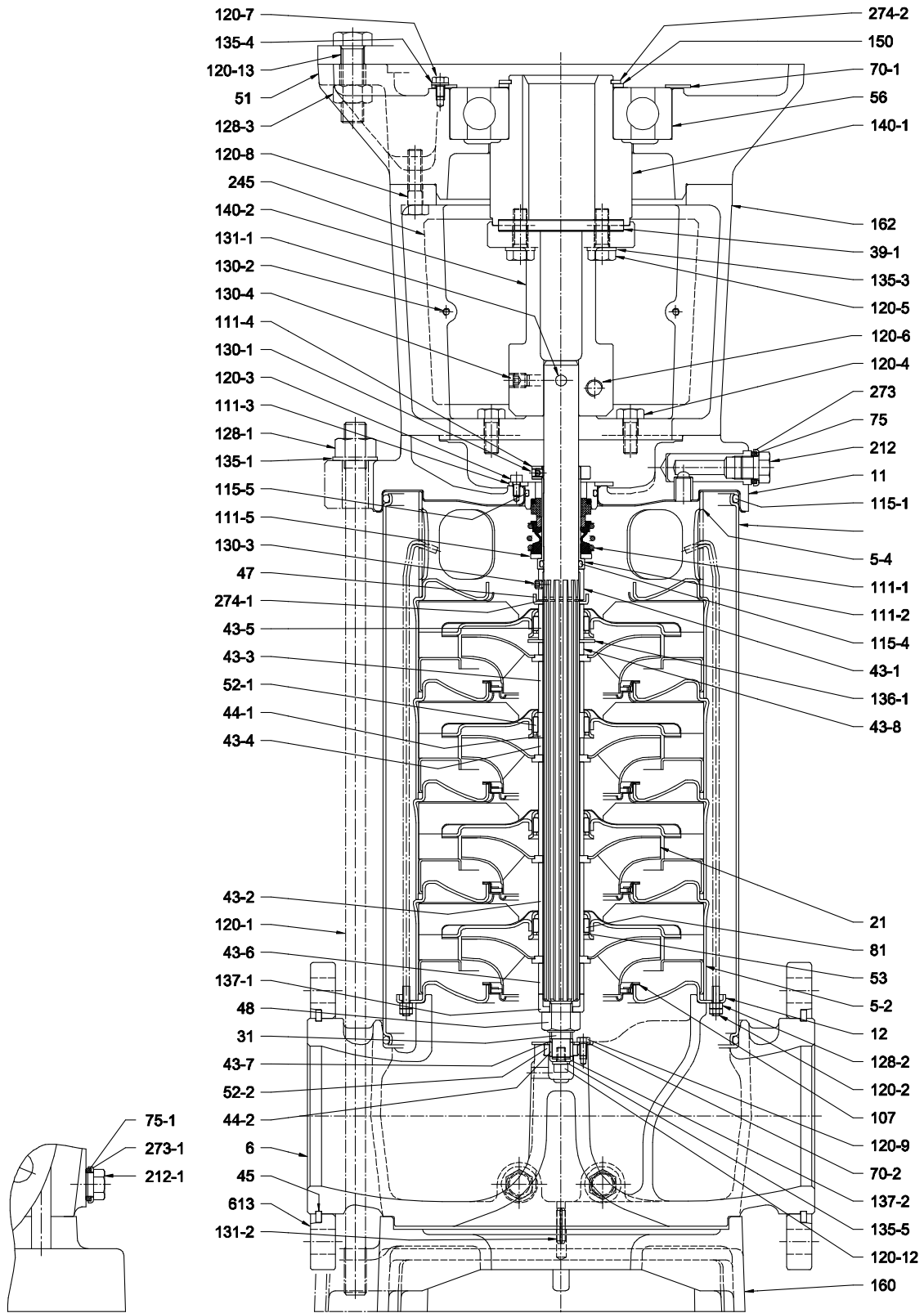

Pump with single ball bearing

SECTIONAL VIEW
EVM(L)64

EVM(L)64

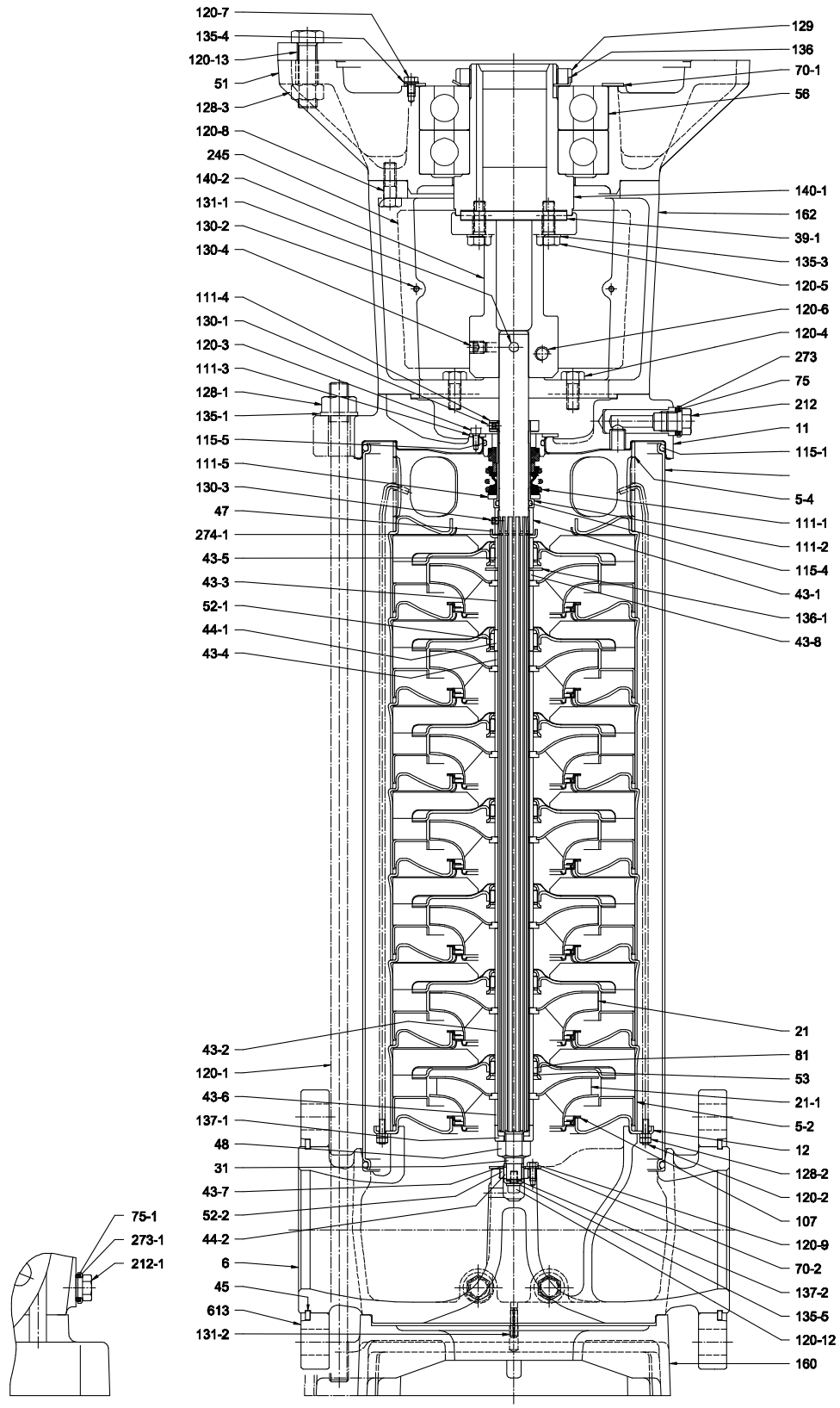

Pump with double ball bearing

SECTIONAL TABLE EVM(L)64

N°	PART NAME	MATERIAL		DIMENSIONS	STANDARD
		EVM	EVML		
5-2	Intermediate casing	EN 1.4301 (AISI 304)	EN 1.4401 (AISI 316)		
5-4	Discharge casing	EN 1.4301 (AISI 304)	EN 1.4401 (AISI 316)		
6	Bottom casing	EN 1.4301 (AISI 304)	EN 1.4401 (AISI 316)		
7	Outer casing	EN 1.4301 (AISI 304)	EN 1.4401 (AISI 316)		
11	Casing cover	Cast iron + EN 1.4301 (AISI 304)	Cast iron + EN 1.4401 (AISI 316)		
12	Suction cover	EN 1.4301 (AISI 304)	EN 1.4401 (AISI 316)		
21	Impeller	EN 1.4301 (AISI 304)	EN 1.4401 (AISI 316)		
21-1	Reduced impeller				
31	Shaft	EN 1.4401 (AISI 316)			
39-1	Key	Carbon steel		12x8x90	UNI 6604
43-1	Shaft sleeve (mechanical seal)	EN 1.4301 (AISI 304)	EN 1.4401 (AISI 316)		
43-2	Shaft sleeve (intermediate)	EN 1.4301 (AISI 304)	EN 1.4401 (AISI 316)		
43-3	Shaft sleeve (bearing)	EN 1.4301 (AISI 304)	EN 1.4401 (AISI 316)		
43-4	Shaft sleeve (adjustment)	EN 1.4301 (AISI 304)	EN 1.4401 (AISI 316)		
43-5	Shaft sleeve (last stage)	EN 1.4301 (AISI 304)	EN 1.4401 (AISI 316)		
43-6	Shaft sleeve (adjustment)	EN 1.4301 (AISI 304)	EN 1.4401 (AISI 316)		
43-7	Shaft sleeve (bottom bearing)	EN 1.4301 (AISI 304)	EN 1.4401 (AISI 316)		
43-8	Shaft sleeve (discharge/lower)	EN 1.4301 (AISI 304)	EN 1.4401 (AISI 316)		
44-1	Shaft sleeve bearing	Tungsten carbide			
44-2	Bearing sleeve	Tungsten carbide			
45	Flange holder	EN 1.402 (AISI 420)			
47	Ring holder	EN 1.4301 (AISI 304)	EN 1.4401 (AISI 316)		
48	Impeller nut	A2-70 UNI 7323 with inox insert	A4-70 UNI 7323 with inox insert	M16	
51	Motor adapter	Cast iron EN-GJL-200-EN 1561			
52-1	Bearing	Tungsten carbide			
52-2	Bearing	Tungsten carbide			
53	Bush holder	EN 1.4301 (AISI 304)	EN 1.4401 (AISI 316)		
56	Ball bearing	see table page 378			
70-1	Ring for bearing	EN 1.4301 (AISI 304)			
70-2	Ring for bearing	EN 1.4301 (AISI 304)	EN 1.4401 (AISI 316)		
75	O-Ring (plug)	EPDM	FPM		
75-1	O-Ring (plug)	EPDM	FPM		
81	Bush	PTFE			
107	Liner ring	PTFE / EN 1.4401 (AISI 316)			
111-1	Mechanical seal	Silicon carbide/Carbon/FPM			
111-2	Mechanical seal cartridge	EN 1.4301 (AISI 304)	EN 1.4401 (AISI 316)		
111-3	Mechanical seal seat	EN 1.4301 (AISI 304)	EN 1.4401 (AISI 316)		
111-4	Seal holder	Brass OT 58 UNI 5705	EN 1.4401 (AISI 316)		
111-5	Adjusting ring	EN 1.4301 (AISI 304)	EN 1.4401 (AISI 316)		
115-1	O-Ring (outer casing)	EPDM	FPM	D.240.66x5.34	
115-4	O-Ring (cartridge sleeve)	EPDM	FPM	D.24.99x3.53	
115-5	O-Ring (seal cover)	EPDM	FPM	D.44.04x3.53	
120-1	Tie-rod	Galvanized steel 6.8 Strenght class ISO 898/1			

SECTIONAL TABLE
EVM(L)64

N°	PART NAME	MATERIAL		DIMENSIONS	STANDARD	
		EVM	EVML			
120-2	Tie-rod	EN 1.4301 (AISI 304)	EN 1.4401 (AISI 316)			
120-3	Screw (mechanical seal)	A2-70 UNI 7323		M5x10	UNI 5931	
120-4	Screw (casing cover)	Galvanized steel 8.8 Strenght class ISO 898/1		M10x25	UNI 5739	
120-5	Screw for coupling	EVM64 1-1	Galvanized steel 8.8 Strenght class ISO 898/1	M8x20	UNI 5931	
		EVM64 2 and higher		M10x30	UNI 5739	
120-6	Screw for coupling	EVM64 1-0, 1-1, 2-2	Galvanized steel 8.8 Strenght class ISO 898/1	M8x20	UNI 5931	
		EVM64 2 and higher		M12x30	UNI 5931	
120-7	Screw	Galvanized steel		M6x10	UNI 5739	
120-8	Screw	EVM64 1-0, 2-2	Galvanized steel 8.8 Strenght class ISO 898/1	M6x10	UNI 5739	
				M10x30	UNI 5739	
120-9	Screw	EVML	EN 1.4301 (AISI 304)	EN 1.4401 (AISI 316)	M5x8	UNI 5737
		EVM, EVMG			M5x8	UNI 5739
120-12	Screw	EN 1.4301 (AISI 304)	EN 1.4401 (AISI 316)	M6x20	UNI 5931	
120-13	Screw	EVM64 1-1	Galvanized steel 8.8 Strenght class ISO 898/1	M8x20	UNI 5739	
		EVM64 1-0, 2-2		M12x30	UNI 5739	
		EVM64 6 to 7		M16x55	UNI 5737	
		EVM64 2 to 5		M16x65	UNI 5739	
128-1	Nut for tie rod	Galvanized steel		M16	UNI 5588	
128-2	Nut	Carbon steel	EN 1.4401 (AISI 316)	M5	UNI 5588	
128-3	Nut	Galvanized steel		M16	UNI 5588	
129	Lock nut	Carbon steel				
130-1	Set screw	A2-70 UNI 7323		M6x8	UNI 5923	
130-2	Screw for coupling guard	A2-70 UNI 7323		M5x6	UNI 7687	
130-3	Set screw	EN 1.4301 (AISI 304)	EN 1.4401 (AISI 316)	M6X6	UNI 5923	
130-4	Set screw	Galvanized steel		M10x10	UNI 5923	
131-1	Pin for shaft	Carbon steel				
131-2	Elastic pin	Galvanized steel		6x25	UNI 6873	
135-1	Washer	Galvanized steel		17x30x3	UNI 6592	
135-3	Washer	Galvanized steel		10.5x17.5x2.2	UNI 1751	
135-4	Washer	Plated carbon steel		6.4	UNI 1751	
135-5	Washer	EN 1.4301 (AISI 304)	EN 1.4401 (AISI 316)	D.6		
136	Bearing washer	Carbon steel				
136-1	Stopper ring	EN 1.4301 (AISI 304)	EN 1.4401 (AISI 316)			
137-1	Impeller spacer	EN 1.4301 (AISI 304)	EN 1.4401 (AISI 316)			
137-2	Shaft spacer	EN 1.4301 (AISI 304)	EN 1.4401 (AISI 316)			
140	Coupling	Brass OT 58 UNI 5705				
140-1	Motor coupling	Carbon steel				
140-2	Coupling (pump side)	Carbon steel				
150	Spacer	Carbon steel				
160	Base	Cast iron EN-GJL-200 EN 1561				
162	Motor bracket	Cast iron EN-GJL-200-EN 1561				
212	Plug	EN 1.4301 (AISI 304)	EN 1.4401 (AISI 316)			
212-1	Plug	EN 1.4301 (AISI 304)	EN 1.4401 (AISI 316)			
245	Coupling guard	EN 1.4301 (AISI 304)				
273	Plug washer	EN 1.4301 (AISI 304)	EN 1.4401 (AISI 316)			
273-1	Plug washer	EN 1.4301 (AISI 304)	EN 1.4401 (AISI 316)			
274-1	C-Type snap ring	EN 1.4301 (AISI 304)	EN 1.4401 (AISI 316)	D.26	UNI 7435	
274-2	C-Type snap ring	EVM64 1-0, 2-2	Carbon steel TC80	D.50	UNI 7435	
		EVM64 2 to 4-3		D.65	UNI 7435	
		EVM64 4-0, 4-1		D.75	UNI 7535	
				D.110	UNI 7437	
274-3	C-Type snap ring	Carbon steel TC80		D.110	UNI 7437	
613	Flange	Carbon steel				

QUANTITY FOR MODEL EVM(L)64

Pump Type	N°																															
	5-2	11	21	21-1	39-1	43-2	43-3	43-4	44-1	51	52-1	53	56	70-1	81	107	120-4	120-5	120-7	120-8	128-3	129	135-3	135-4	136	140	140-1	140-2	150	274-2	274-3	
EVM(L)64 1-1F5/4.0	1	/	/	1	/	/	/	/	/	/	/	/	/	1	/	1	1	/	2	/	/	/	/	/	/	1	1	/	/	/	/	/
EVM(L)64 1-0F5/5.5	1	/	1	/	/	/	/	/	/	1	/	1	1	/	1	1	/	/	/	4	/	/	/	/	/	1	1	/	/	1	1	1
EVM(L)64 2-2F5/7.5	2	/	/	2	/	1	/	/	/	1	/	2	1	/	2	2	/	/	/	4	/	/	/	/	1	1	/	/	1	1	1	
EVM(L)64 2-1F5/11	2	1	1	1	1	1	/	/	/	1	/	2	1	1	2	2	4	4	3	4	4	/	4	3	1	/	1	1	1	1	/	
EVM(L)64 2-0F5/11	2	1	2	/	1	1	/	/	/	1	/	2	1	1	2	2	4	4	3	4	4	/	4	3	1	/	1	1	1	1	/	
EVM(L)64 3-3F5/15	3	1	/	3	1	2	/	/	/	1	/	3	1	1	3	3	4	4	3	4	4	/	4	3	1	/	1	1	1	1	/	
EVM(L)64 3-2F5/15	3	1	1	2	1	2	/	/	/	1	/	3	1	1	3	3	4	4	3	4	4	/	4	3	1	/	1	1	1	1	/	
EVM(L)64 3-1F5/15	3	1	2	1	1	2	/	/	/	1	/	3	1	1	3	3	4	4	3	4	4	/	4	3	1	/	1	1	1	1	/	
EVM(L)64 3-0F5/18.5	3	1	3	/	1	2	/	/	/	1	/	3	1	1	3	3	4	4	3	4	4	/	4	3	1	/	1	1	1	1	/	
EVM(L)64 4-3F5/18.5	4	1	1	3	1	2	1	1	1	1	1	4	1	1	3	4	4	4	3	4	4	/	4	3	1	/	1	1	1	1	/	
EVM(L)64 4-2F5/18.5	4	1	2	2	1	2	1	1	1	1	1	4	1	1	3	4	4	4	3	4	4	/	4	3	1	/	1	1	1	1	/	
EVM(L)64 4-1F5/22	4	1	3	1	1	2	1	1	1	1	1	4	1	1	3	4	4	4	3	4	4	/	4	3	1	/	1	1	1	1	/	
EVM(L)64 4-0F5/22	4	1	4	/	1	2	1	1	1	1	1	4	1	1	3	4	4	4	3	4	4	/	4	3	1	/	1	1	1	1	/	
EVM(L)64 5-3F5/30	5	1	2	3	1	3	1	1	1	1	1	5	1	1	4	5	4	4	3	4	4	1	4	3	2	/	1	1	1	1	/	
EVM(L)64 5-2F5/30	5	1	3	2	1	3	1	1	1	1	1	5	1	1	4	5	4	4	3	4	4	1	4	3	2	/	1	1	1	1	/	
EVM(L)64 5-1F5/30	5	1	4	1	1	3	1	1	1	1	1	5	1	1	4	5	4	4	3	4	4	1	4	3	2	/	1	1	1	1	/	
EVM(L)64 5-0F5/30	5	1	5	/	1	3	1	1	1	1	1	5	1	1	4	5	4	4	3	4	4	1	4	3	2	/	1	1	1	1	/	
EVM(L)64 6-3F5/30	6	1	3	3	1	4	1	1	1	1	1	6	1	1	5	6	4	4	3	4	4	1	4	3	2	/	1	1	1	1	/	
EVM(L)64 6-2F5/30	6	1	4	2	1	4	1	1	1	1	1	6	1	1	5	6	4	4	3	4	4	1	4	3	2	/	1	1	1	1	/	
EVM(L)64 6-1F5/37	6	1	5	1	1	4	1	1	1	1	1	6	1	1	5	6	4	4	3	4	4	1	4	3	2	/	1	1	1	1	/	
EVM(L)64 6-0F5/37	6	1	6	/	1	4	1	1	1	1	1	6	1	1	5	6	4	4	3	4	4	1	4	3	2	/	1	1	1	1	/	
EVM(L)64 7-3F5/37	7	1	4	3	1	5	1	1	1	1	1	7	1	1	6	7	4	4	3	4	4	1	4	3	2	/	1	1	1	1	/	
EVM(L)64 7-2F5/37	7	1	5	2	1	5	1	1	1	1	1	7	1	1	6	7	4	4	3	4	4	1	4	3	2	/	1	1	1	1	/	
EVM(L)64 7-1F5/37	7	1	6	1	1	5	1	1	1	1	1	7	1	1	6	7	4	4	3	4	4	1	4	3	2	/	1	1	1	1	/	

BEARINGS EVM(L)64

Pump Type	N°
EVM(L)64 1-1F5/4.0	/
EVM(L)64 1-0F5/5.5	6310 ZZ C3
EVM(L)64 2-2F5/7.5	6310 ZZ C3
EVM(L)64 2-1F5/11	6313 ZZ C3
EVM(L)64 2-0F5/11	6313 ZZ C3
EVM(L)64 3-3F5/15	6313 ZZ C3
EVM(L)64 3-2F5/15	6313 ZZ C3
EVM(L)64 3-1F5/15	6313 ZZ C3
EVM(L)64 3-0F5/18.5	6313 ZZ C3
EVM(L)64 4-3F5/18.5	6313 ZZ C3
EVM(L)64 4-2F5/18.5	6313 ZZ C3
EVM(L)64 4-1F5/22	6315 ZZ C3
EVM(L)64 4-0F5/22	6315 ZZ C3
EVM(L)64 5-3F5/30	6315 ZZDT C3 *
EVM(L)64 5-2F5/30	6315 ZZDT C3 *
EVM(L)64 5-1F5/30	6315 ZZDT C3 *
EVM(L)64 5-0F5/30	6315 ZZDT C3 *
EVM(L)64 6-3F5/30	6315 ZZDT C3 *
EVM(L)64 6-2F5/30	6315 ZZDT C3 *
EVM(L)64 6-1F5/37	6315 ZZDT C3 *
EVM(L)64 6-0F5/37	6315 ZZDT C3 *
EVM(L)64 7-3F5/37	6315 ZZDT C3 *
EVM(L)64 7-2F5/37	6315 ZZDT C3 *
EVM(L)64 7-1F5/37	6315 ZZDT C3 *

*DT=Two single row deep groove ball bearings matched for paired mounting in a tandem arrangement.

PERFORMANCE CURVE
EVMG64

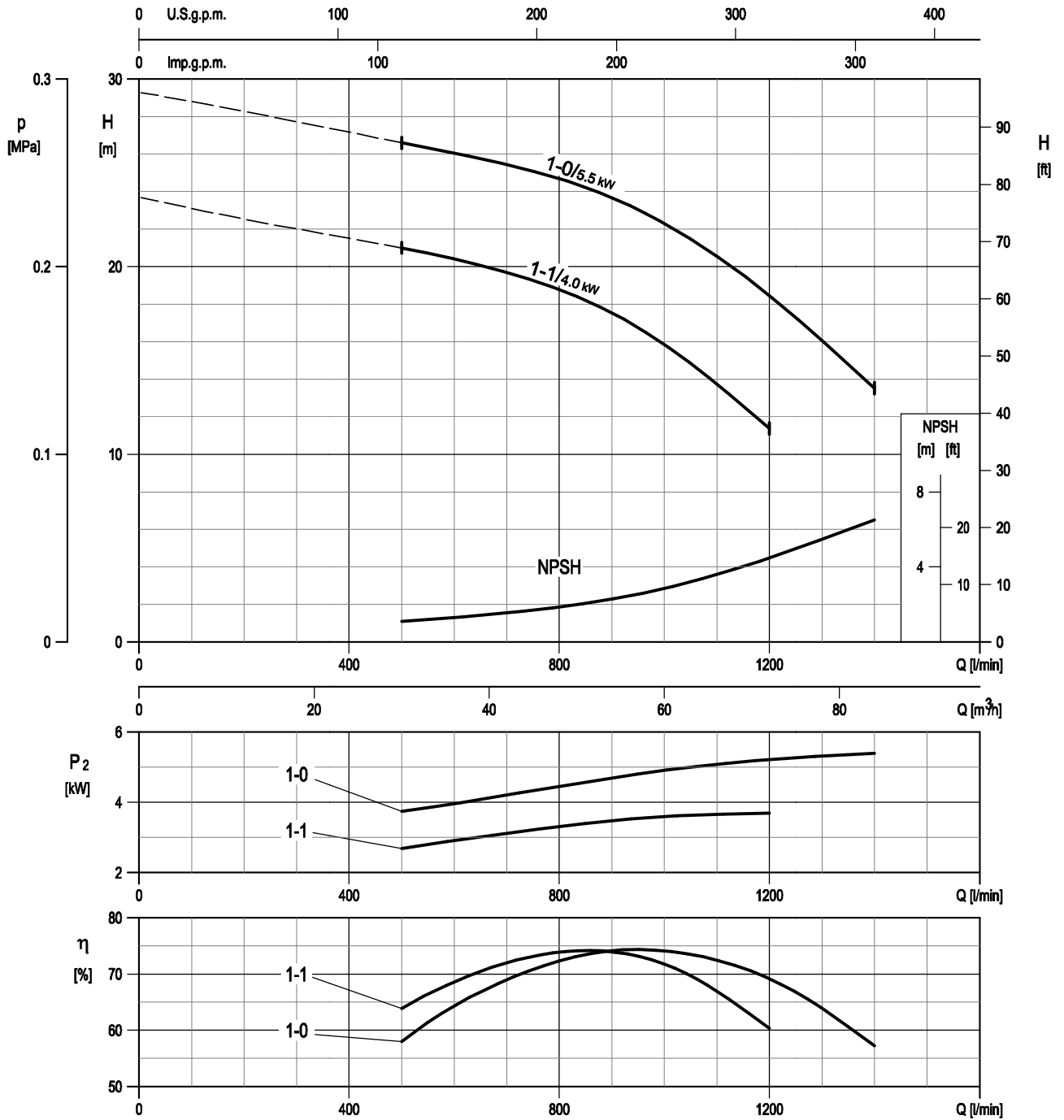

Rotation speed $\approx 2900 \text{ min}^{-1}$
Test standard: ISO 9906:2012 - Grade 3B

PERFORMANCE CURVE EVMG64

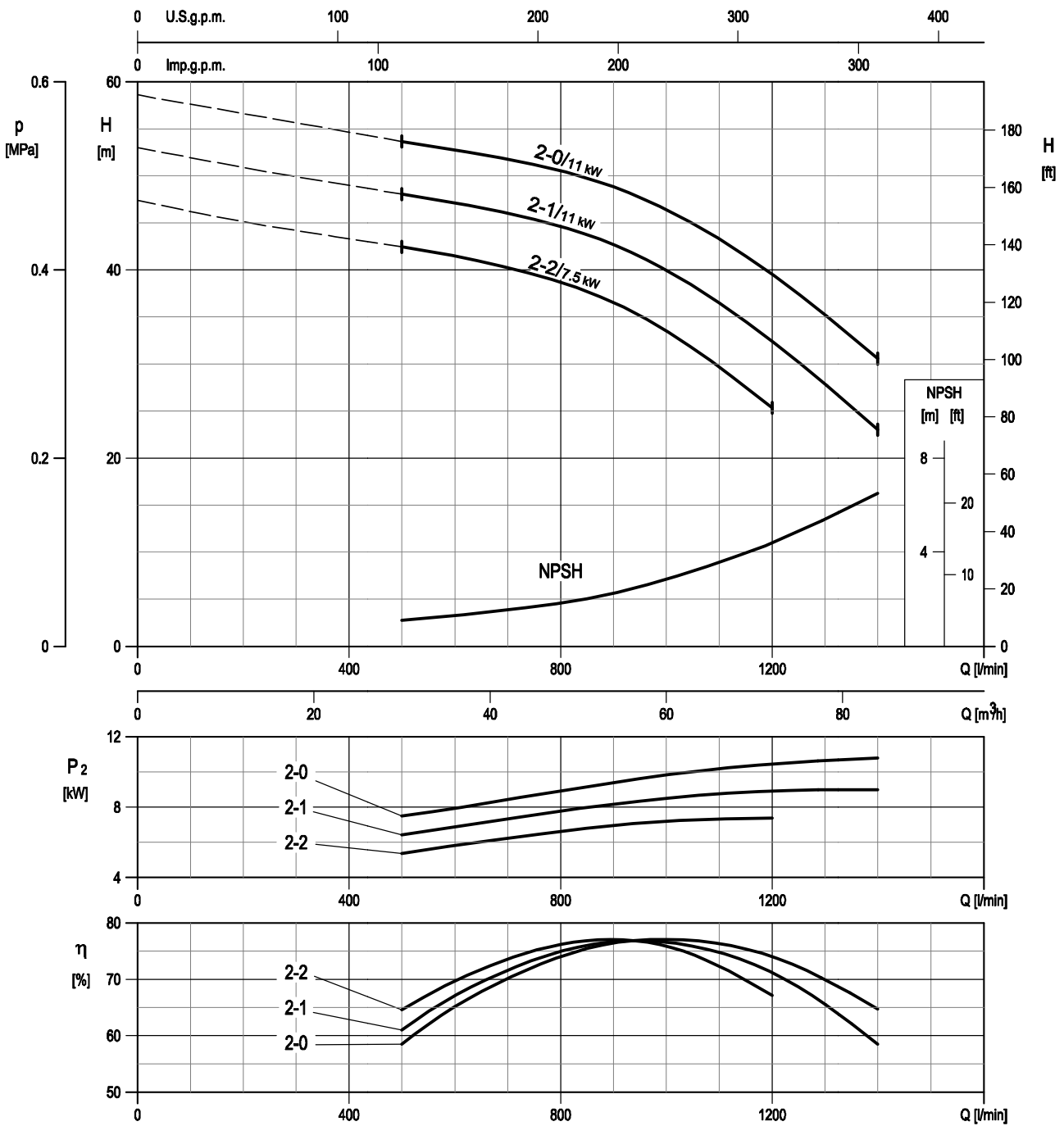

Rotation speed $\approx 2900 \text{ min}^{-1}$
 Test standard: ISO 9906:2012 - Grade 3B

EVMG64

PERFORMANCE CURVE
EVMG64

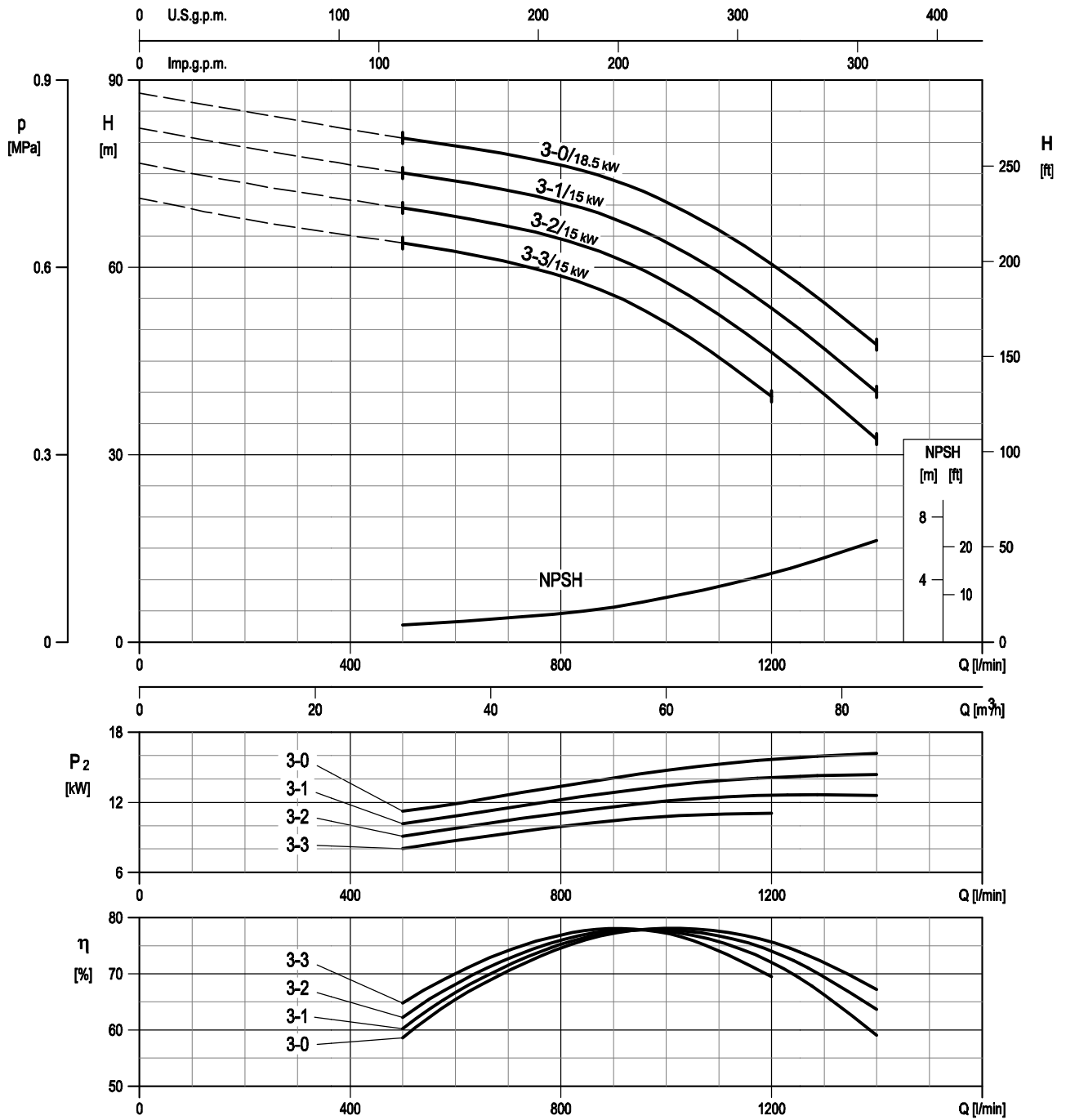

Rotation speed $\approx 2900 \text{ min}^{-1}$
Test standard: ISO 9906:2012 - Grade 3B

EVMG64

PERFORMANCE CURVE EVMG64

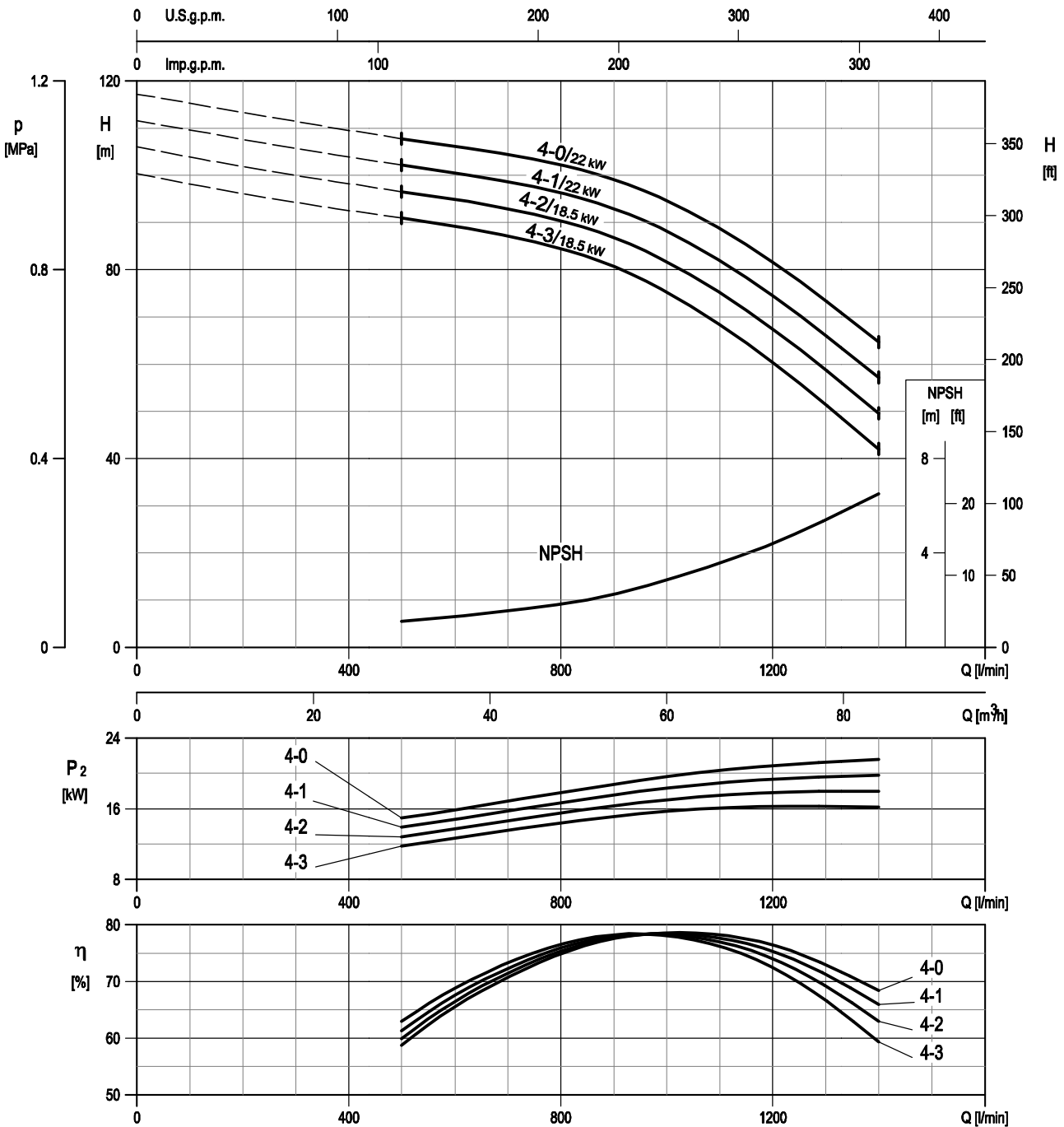

Rotation speed $\approx 2900 \text{ min}^{-1}$
 Test standard: ISO 9906:2012 - Grade 3B

EVMG64

PERFORMANCE CURVE
EVMG64

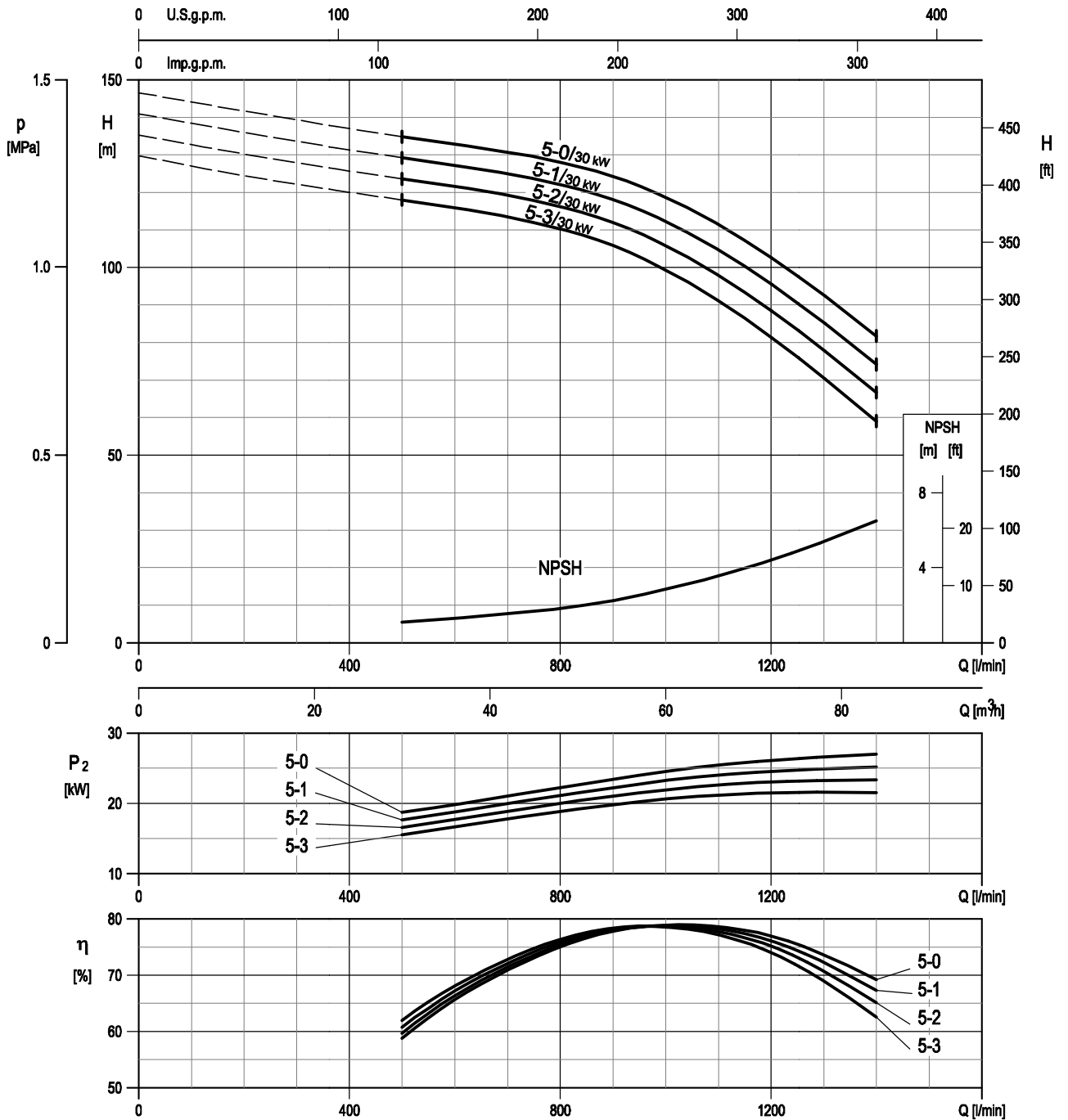

Rotation speed $\approx 2900 \text{ min}^{-1}$
Test standard: ISO 9906:2012 - Grade 3B

PERFORMANCE CURVE EVMG64

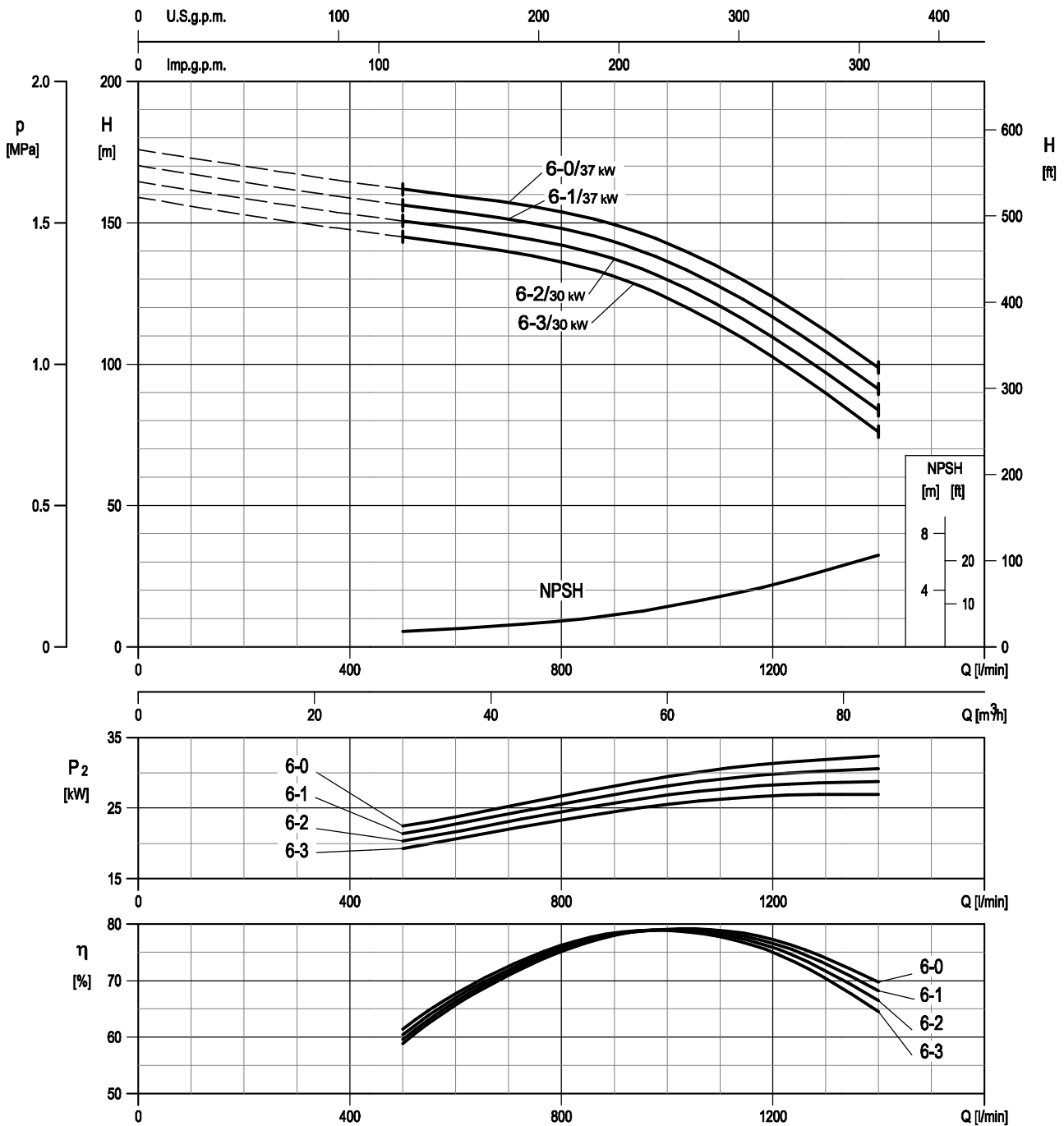

Rotation speed $\approx 2900 \text{ min}^{-1}$
 Test standard: ISO 9906:2012 - Grade 3B

EVMG64

PERFORMANCE CURVE
EVMG64

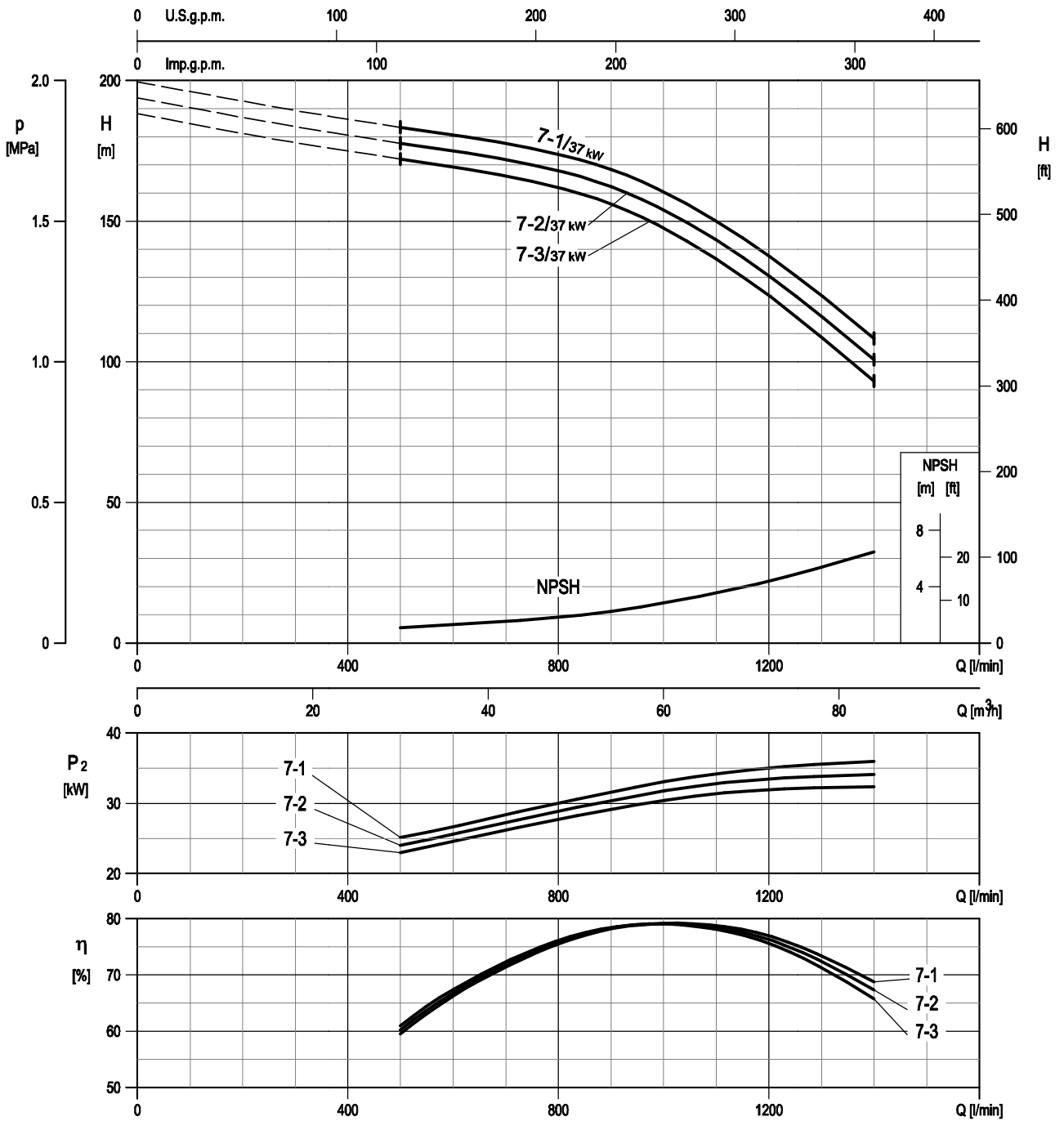

Rotation speed $\approx 2900 \text{ min}^{-1}$
Test standard: ISO 9906:2012 - Grade 3B

TECHNICAL DATA EVMG64

Dimensional sketch

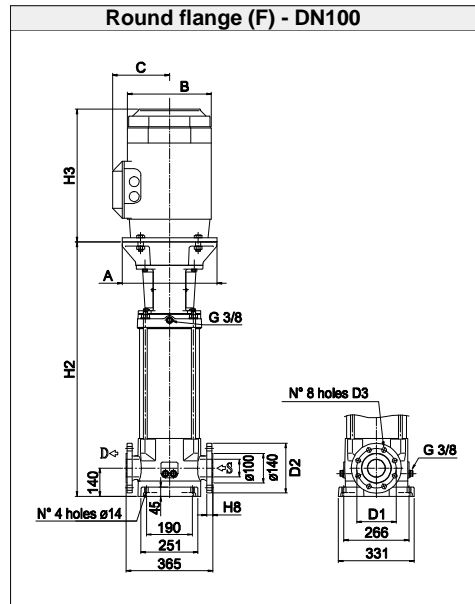

Dimensions [mm] and Weights [Kg]

Pump Type	Pmax [MPa]	kW	Motor				Round flange (F)					Weight Pump	Weight Pump + Motor	
			Size	A	3 ~			H2	D1	D2	D3			H8
EVMG64 1-1F5/4.0	1.6	4.0	112 M	160	196	155	306	525	ø180	ø220	ø18	20	70.4	93.2
EVMG64 1-0F5/5.5	1.6	5.5	132 S	300	225	160	328	546	ø180	ø220	ø18	20	77	115.6
EVMG64 2-2F5/7.5	1.6	7.5	132 S	300	225	160	350	618	ø180	ø220	ø18	20	81.4	121.8
EVMG64 2-1F5/11	1.6	11	160 M	350	248	194	476	749	ø180	ø220	ø18	20	93.5	156
EVMG64 2-0F5/11	1.6	11	160 M	350	248	194	476	749	ø180	ø220	ø18	20	93.5	156
EVMG64 3-3F5/15	1.6	15	160 M	350	317	238	498	821	ø180	ø220	ø18	20	99	187.9
EVMG64 3-2F5/15	1.6	15	160 M	350	317	238	498	821	ø180	ø220	ø18	20	99	187.9
EVMG64 3-1F5/15	1.6	15	160 M	350	317	238	498	821	ø180	ø220	ø18	20	99	187.9
EVMG64 3-0F5/18.5	1.6	18.5	160 L	350	317	238	542	821	ø180	ø220	ø18	20	99	203
EVMG64 4-3F5/18.5	1.6	18.5	160 L	350	317	238	542	893	ø180	ø220	ø18	20	108	212
EVMG64 4-2F5/18.5	1.6	18.5	160 L	350	317	238	542	893	ø180	ø220	ø18	20	108	212
EVMG64 4-1F5/22	1.6	22	180 M	350	360	268	577	893	ø180	ø220	ø18	20	116	279
EVMG64 4-0F5/22	1.6	22	180 M	350	360	268	577	893	ø180	ø220	ø18	20	116	279
EVMG64 5-3F5/30	1.6	30	200 L	400	399	300	658	980	ø180	ø220	ø18	20	128	356
EVMG64 5-2F5/30	1.6	30	200 L	400	399	300	658	980	ø180	ø220	ø18	20	128	356
EVMG64 5-1F5/30	1.6	30	200 L	400	399	300	658	980	ø180	ø220	ø18	20	128	356
EVMG64 5-0F5/30	1.6	30	200 L	400	399	300	658	980	ø180	ø220	ø18	20	128	356
EVMG64 6-3F5/30	1.6	30	200 L	400	399	300	658	1052	ø180	ø220	ø18	20	136	364
EVMG64 6-2F5/30	2.5	30	200 L	400	399	300	658	1052	ø190	ø235	ø22	26	136	364
EVMG64 6-1F5/37	2.5	37	200 L	400	399	300	658	1052	ø190	ø235	ø22	26	136	378
EVMG64 6-0F5/37	2.5	37	200 L	400	399	300	658	1052	ø190	ø235	ø22	26	136	378
EVMG64 7-3F5/37	2.5	37	200 L	400	399	300	658	1124	ø190	ø235	ø22	26	139	381
EVMG64 7-2F5/37	2.5	37	200 L	400	399	300	658	1124	ø190	ø235	ø22	26	139	381
EVMG64 7-1F5/37	2.5	37	200 L	400	399	300	658	1124	ø190	ø235	ø22	26	139	381

1.6 MPa=16 bar ; 2.5 MPa=25 bar

SECTIONAL VIEW
EVMG64

EVMG64

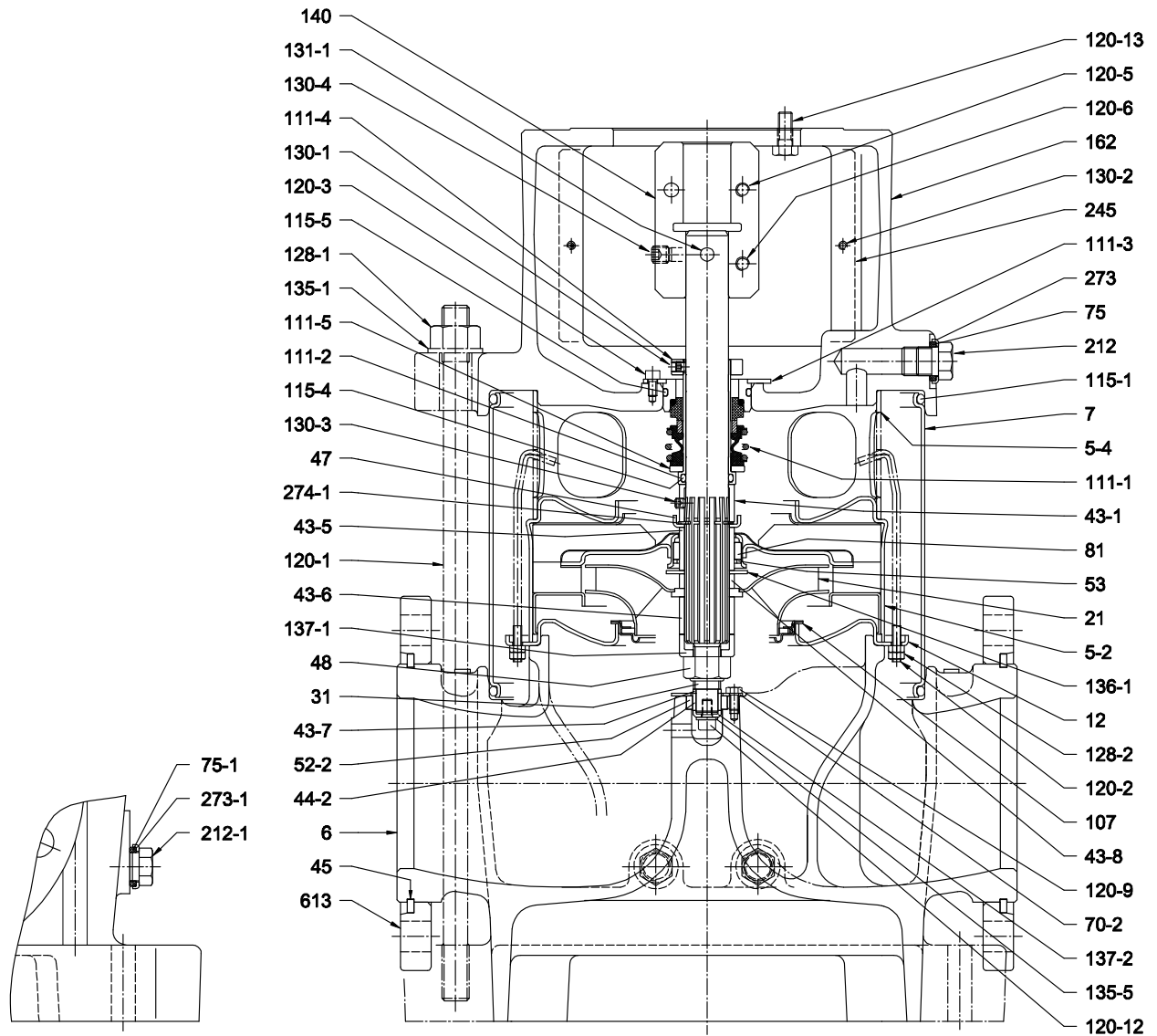

Pump without ball bearing

SECTIONAL VIEW EVMG64

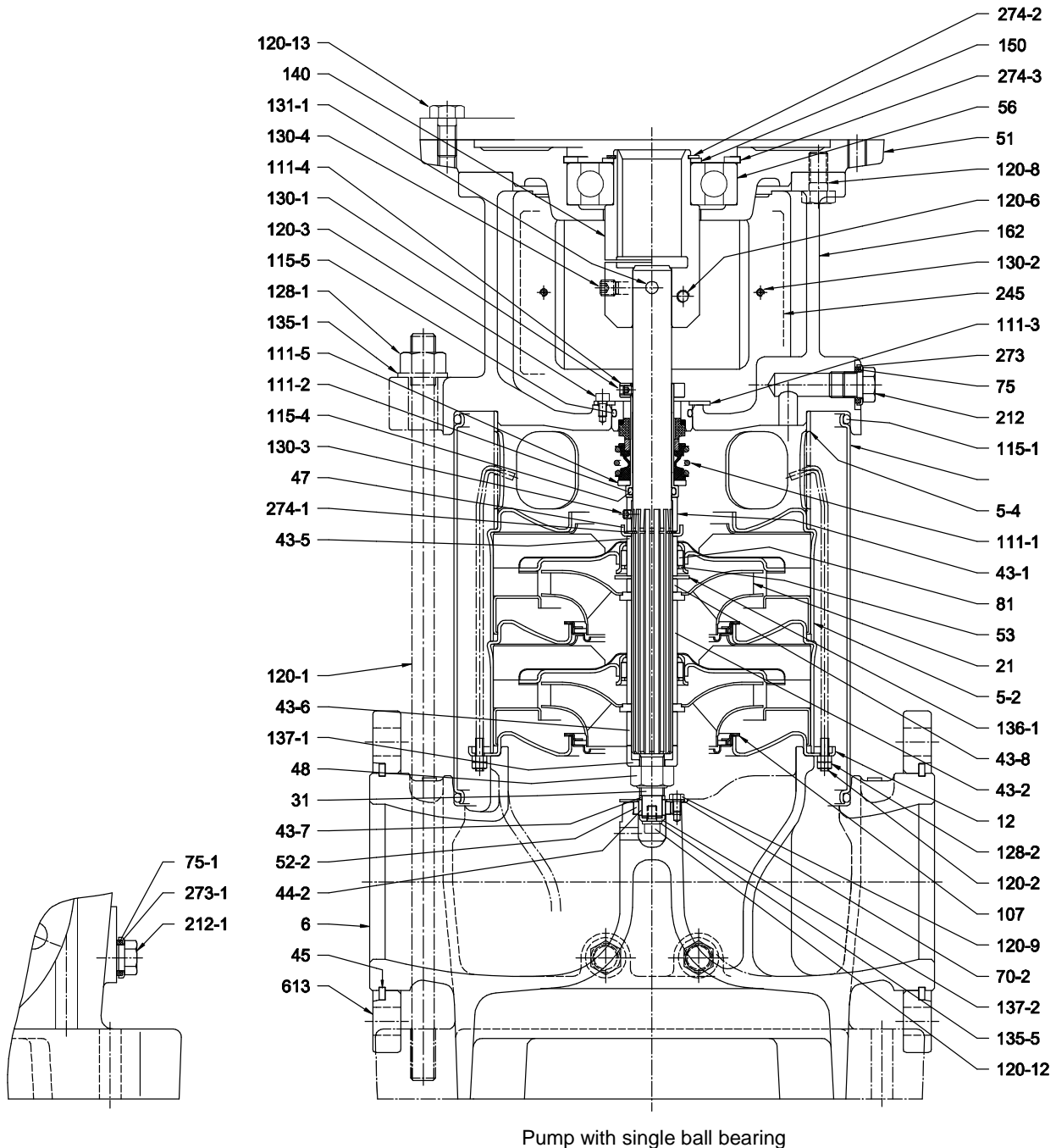

EVMG64

SECTIONAL VIEW
EVMG64

EVMG64

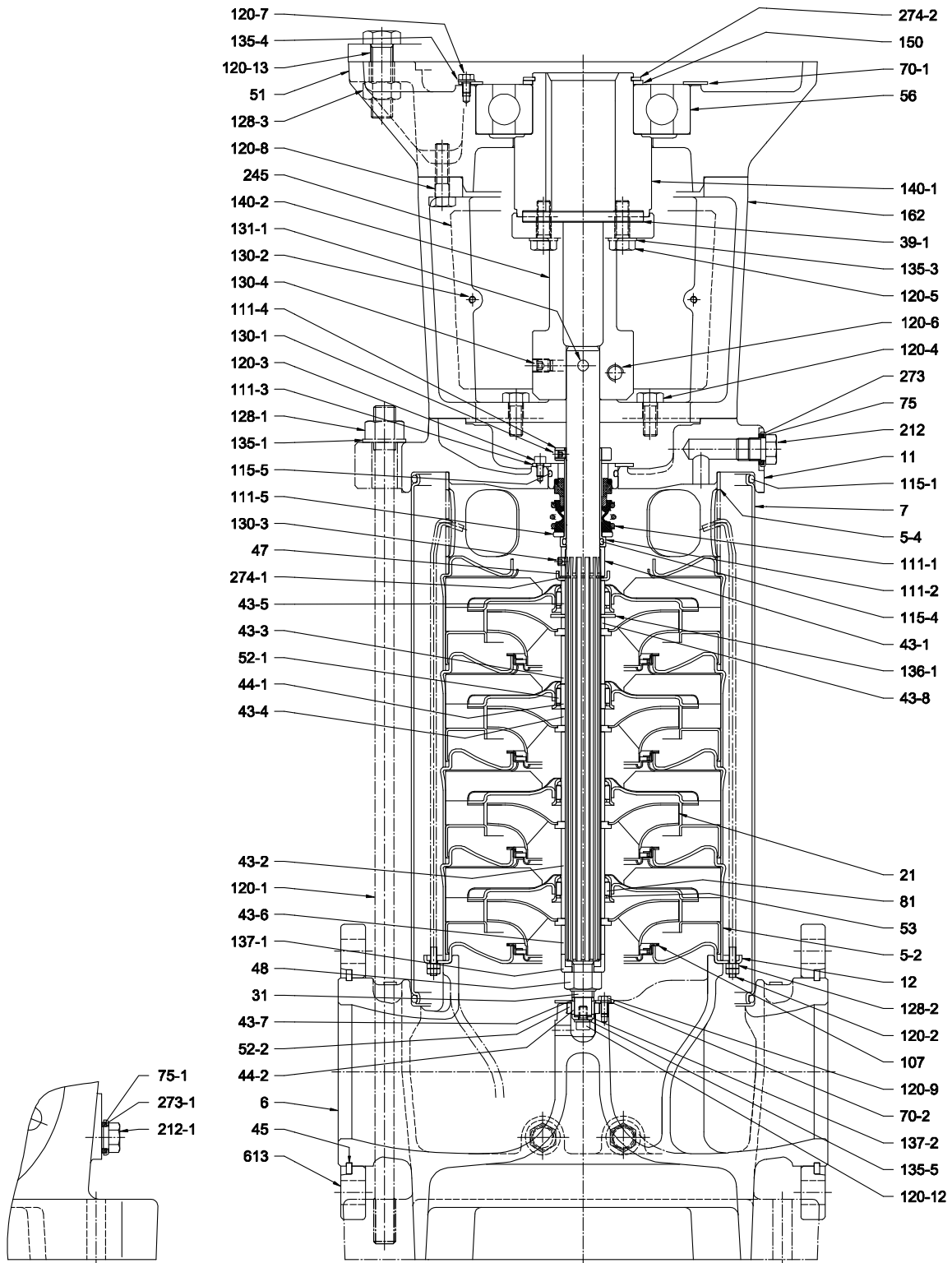

Pump with single ball bearing

SECTIONAL VIEW EVMG64

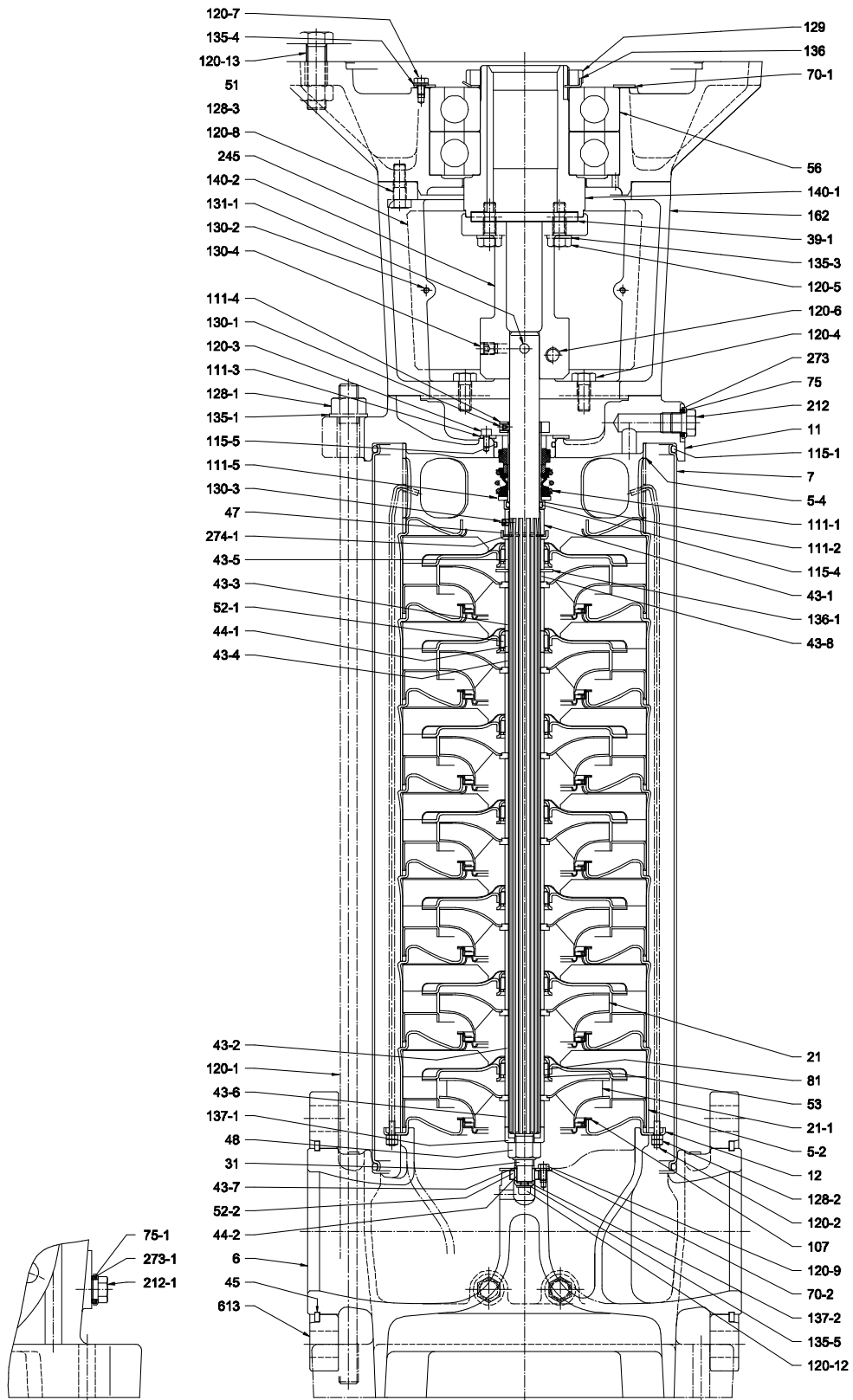

Pump with double ball bearing

EVMG64

SECTIONAL TABLE
EVMG64

N°	PART NAME	MATERIAL EVMG	DIMENSIONS	STANDARD
5-2	Intermediate casing	EN 1.4301 (AISI 304)		
5-4	Discharge casing	EN 1.4301 (AISI 304)		
6	Bottom casing	Cast iron EN GJL-250 - EN 1561		
7	Outer casing	EN 1.4301 (AISI 304)		
11	Casing cover	Cast iron EN GJL-250 - EN 1561		
12	Suction cover	EN 1.4301 (AISI 304)		
21	Impeller	EN 1.4301 (AISI 304)		
21-1	Reduced impeller			
31	Shaft	EN 1.4401 (AISI 316)		
39-1	Key	Carbon steel	12x8x90	UNI 6604
43-1	Shaft sleeve (mechanical seal)	EN 1.4301 (AISI 304)		
43-2	Shaft sleeve (intermediate)	EN 1.4301 (AISI 304)		
43-3	Shaft sleeve (bearing)	EN 1.4301 (AISI 304)		
43-4	Shaft sleeve (adjustment)	EN 1.4301 (AISI 304)		
43-5	Shaft sleeve (last stage)	EN 1.4301 (AISI 304)		
43-6	Shaft sleeve (adjustment)	EN 1.4301 (AISI 304)		
43-7	Shaft sleeve (bottom bearing)	EN 1.4301 (AISI 304)		
43-8	Shaft sleeve (discharge/lower)	EN 1.4301 (AISI 304)		
44-1	Shaft sleeve bearing	Tungsten carbide		
44-2	Bearing sleeve	Tungsten carbide		
45	Flange holder	EN 1.402 (AISI 420)		
47	Ring holder	EN 1.4301 (AISI 304)		
48	Impeller nut	A2-70 UNI 7323 with inox insert	M16	
51	Motor adapter	Cast iron EN-GJL-200-EN 1561		
52-1	Bearing	Tungsten carbide		
52-2	Bearing	Tungsten carbide		
53	Bush holder	EN 1.4301 (AISI 304)		
56	Ball bearing	see table page 393		
70-1	Ring for bearing	EN 1.4301 (AISI 304)		
70-2	Ring for bearing	EN 1.4301 (AISI 304)		
75	O-Ring (plug)	EPDM		
75-1	O-Ring (plug)	EPDM		
81	Bush	PTFE		
107	Liner ring	PTFE / EN 1.4401 (AISI 316)		
111-1	Mechanical seal	Silicon carbide/Carbon/FPM		
111-2	Mechanical seal cartridge	EN 1.4301 (AISI 304)		
111-3	Mechanical seal seat	EN 1.4301 (AISI 304)		
111-4	Seal holder	Brass OT 58 UNI 5705		
111-5	Adjusting ring	EN 1.4301 (AISI 304)		
115-1	O-Ring (outer casing)	EPDM	D.240.66x5.34	
115-4	O-Ring (cartridge sleeve)	EPDM	D.24.99x3.53	
115-5	O-Ring (seal cover)	EPDM	D.44.04x3.53	
120-1	Tie-rod	Galvanized steel 6.8 Strength class ISO 898/1		

SECTIONAL TABLE EVMG64

N°	PART NAME	MATERIAL EVMG	DIMENSIONS	STANDARD	
120-2	Tie-rod	EN 1.4301 (AISI 304)			
120-3	Screw (mechanical seal)	A2-70 UNI 7323	M5x10	UNI 5931	
120-4	Screw (casing cover)	Galvanized steel 8.8 Strenght class ISO 898/1	M10x25	UNI 5739	
120-5	Screw for coupling	EVM64 1-1	M8x20	UNI 5931	
		EVM64 2 and higher	M10x30	UNI 5739	
120-6	Screw for coupling	EVM64 1-0, 1-1, 2-2	M8x20	UNI 5931	
		EVM64 2 and higher	M12x30	UNI 5931	
120-7	Screw	Galvanized steel	M6x10	UNI 5739	
120-8	Screw	Galvanized steel 8.8 Strenght class ISO 898/1	M6x10	UNI 5739	
			M10x30	UNI 5739	
120-9	Screw	EN 1.4301 (AISI 304)	M5x8	UNI 5737	
			M5x8	UNI 5739	
120-12	Screw	EN 1.4301 (AISI 304)	M6x20	UNI 5931	
120-13	Screw	Galvanized steel 8.8 Strenght class ISO 898/1	EVM64 1-1	M8x20	UNI 5739
			EVM64 1-0, 2-2	M12x30	UNI 5739
			EVM64 6 to 7	M16x55	UNI 5737
			EVM64 2 to 5	M16x65	UNI 5739
128-1	Nut for tie rod	Galvanized steel	M16	UNI 5588	
128-2	Nut	Carbon steel	M5	UNI 5588	
128-3	Nut	Galvanized steel	M16	UNI 5588	
129	Lock nut	Carbon steel			
130-1	Set screw	A2-70 UNI 7323	M6x8	UNI 5923	
130-2	Screw for coupling guard	A2-70 UNI 7323	M5x6	UNI 7687	
130-3	Set screw	EN 1.4301 (AISI 304)	M6X6	UNI 5923	
130-4	Set screw	Galvanized steel	M10x10	UNI 5923	
131-1	Pin for shaft	Carbon steel			
131-2	Elastic pin	-	6x25	UNI 6873	
135-1	Washer	Galvanized steel	17x30x3	UNI 6592	
135-3	Washer	Galvanized steel	10.5x17.5x2.2	UNI 1751	
135-4	Washer	Plated carbon steel	6.4	UNI 1751	
135-5	Washer	EN 1.4301 (AISI 304)	D.6		
136	Bearing washer	Carbon steel			
136-1	Stopper ring	EN 1.4301 (AISI 304)			
137-1	Impeller spacer	EN 1.4301 (AISI 304)			
137-2	Shaft spacer	EN 1.4301 (AISI 304)			
140	Coupling	Brass OT 58 UNI 5705			
140-1	Motor coupling	Carbon steel			
140-2	Coupling (pump side)	Carbon steel			
150	Spacer	Carbon steel			
160	Base	-			
162	Motor bracket	Cast iron EN-GJL-200-EN 1561			
212	Plug	EN 1.4301 (AISI 304)			
212-1	Plug	EN 1.4301 (AISI 304)			
245	Coupling guard	EN 1.4301 (AISI 304)			
273	Plug washer	EN 1.4301 (AISI 304)			
273-1	Plug washer	EN 1.4301 (AISI 304)			
274-1	C-Type snap ring	EN 1.4301 (AISI 304)	D.26	UNI 7435	
			D.50	UNI 7435	
274-2	C-Type snap ring	Carbon steel TC80	D.65	UNI 7435	
			D.75	UNI 7535	
			D.110	UNI 7437	
274-3	C-Type snap ring	Carbon steel TC80			
613	Flange	Carbon steel			

QUANTITY FOR MODEL EVMG64

Pump Type	N°																																
	5-2	11	21	21-1	39-1	43-2	43-3	43-4	44-1	51	52-1	53	56	70-1	81	107	120-4	120-5	120-7	120-8	128-3	129	135-3	135-4	136	140	140-1	140-2	150	274-2	274-3		
EVMG64 1-1F5/4.0	1	/	/	1	/	/	/	/	/	/	/	1	/	/	1	1	/	2	/	/	/	/	/	/	1	1	/	/	/	/	/		
EVMG64 1-0F5/5.5	1	/	1	/	/	/	/	/	/	1	/	1	/	1	1	/	1	/	/	/	/	/	/	/	1	1	/	/	/	1	1	1	
EVMG64 2-2F5/7.5	2	/	/	2	/	1	/	/	/	1	/	2	1	/	2	2	/	/	/	4	/	/	/	/	1	1	/	/	1	1	1	1	
EVMG64 2-1F5/11	2	1	1	1	1	1	/	/	/	1	/	2	1	1	2	2	4	4	3	4	4	4	4	3	1	/	1	1	1	1	1	/	
EVMG64 2-0F5/11	2	1	2	/	1	1	/	/	/	1	/	2	1	1	2	2	4	4	3	4	4	4	4	3	1	/	1	1	1	1	1	/	
EVMG64 3-3F5/15	3	1	/	3	1	2	/	/	/	1	/	3	1	1	3	3	4	4	3	4	4	4	4	3	1	/	1	1	1	1	1	/	
EVMG64 3-2F5/15	3	1	1	2	1	2	/	/	/	1	/	3	1	1	3	3	4	4	3	4	4	4	4	3	1	/	1	1	1	1	1	/	
EVMG64 3-1F5/15	3	1	2	1	1	2	/	/	/	1	/	3	1	1	3	3	4	4	3	4	4	4	4	3	1	/	1	1	1	1	1	/	
EVMG64 3-0F5/18.5	3	1	3	/	1	2	/	/	/	1	/	3	1	1	3	3	4	4	3	4	4	4	4	3	1	/	1	1	1	1	1	/	
EVMG64 4-3F5/18.5	4	1	1	3	1	2	1	1	1	1	1	4	1	1	3	4	4	4	3	4	4	4	4	3	1	/	1	1	1	1	1	/	
EVMG64 4-2F5/18.5	4	1	2	2	1	2	1	1	1	1	1	4	1	1	3	4	4	4	3	4	4	4	4	3	1	/	1	1	1	1	1	/	
EVMG64 4-1F5/22	4	1	3	1	1	2	1	1	1	1	1	4	1	1	3	4	4	4	3	4	4	4	4	3	1	/	1	1	1	1	1	/	
EVMG64 4-0F5/22	4	1	4	/	1	2	1	1	1	1	1	4	1	1	3	4	4	4	3	4	4	4	4	3	1	/	1	1	1	1	1	/	
EVMG64 5-3F5/30	5	1	2	3	1	3	1	1	1	1	1	5	1	1	4	5	4	4	3	4	4	4	4	1	4	3	2	/	1	1	/	/	/
EVMG64 5-2F5/30	5	1	3	2	1	3	1	1	1	1	1	5	1	1	4	5	4	4	3	4	4	4	4	1	4	3	2	/	1	1	/	/	/
EVMG64 5-1F5/30	5	1	4	1	1	3	1	1	1	1	1	5	1	1	4	5	4	4	3	4	4	4	4	1	4	3	2	/	1	1	/	/	/
EVMG64 5-0F5/30	5	1	5	/	1	3	1	1	1	1	1	5	1	1	4	5	4	4	3	4	4	4	4	1	4	3	2	/	1	1	/	/	/
EVMG64 6-3F5/30	6	1	3	3	1	4	1	1	1	1	1	6	1	1	5	6	4	4	3	4	4	4	4	1	4	3	2	/	1	1	/	/	/
EVMG64 6-2F5/30	6	1	4	2	1	4	1	1	1	1	1	6	1	1	5	6	4	4	3	4	4	4	4	1	4	3	2	/	1	1	/	/	/
EVMG64 6-1F5/37	6	1	5	1	1	4	1	1	1	1	1	6	1	1	5	6	4	4	3	4	4	4	4	1	4	3	2	/	1	1	/	/	/
EVMG64 6-0F5/37	6	1	6	/	1	4	1	1	1	1	1	6	1	1	5	6	4	4	3	4	4	4	4	1	4	3	2	/	1	1	/	/	/
EVMG64 7-3F5/37	7	1	4	3	1	5	1	1	1	1	1	7	1	1	6	7	4	4	3	4	4	4	4	1	4	3	2	/	1	1	/	/	/
EVMG64 7-2F5/37	7	1	5	2	1	5	1	1	1	1	1	7	1	1	6	7	4	4	3	4	4	4	4	1	4	3	2	/	1	1	/	/	/
EVMG64 7-1F5/37	7	1	6	1	1	5	1	1	1	1	1	7	1	1	6	7	4	4	3	4	4	4	4	1	4	3	2	/	1	1	/	/	/

EVMG64

BEARINGS EVMG64

Pump Type	N°
EVMG64 1-1F5/4.0	/
EVMG64 1-0F5/5.5	6310 ZZ C3
EVMG64 2-2F5/7.5	6310 ZZ C3
EVMG64 2-1F5/11	6313 ZZ C3
EVMG64 2-0F5/11	6313 ZZ C3
EVMG64 3-3F5/15	6313 ZZ C3
EVMG64 3-2F5/15	6313 ZZ C3
EVMG64 3-1F5/15	6313 ZZ C3
EVMG64 3-0F5/18.5	6313 ZZ C3
EVMG64 4-3F5/18.5	6313 ZZ C3
EVMG64 4-2F5/18.5	6313 ZZ C3
EVMG64 4-1F5/22	6315 ZZ C3
EVMG64 4-0F5/22	6315 ZZ C3
EVMG64 5-3F5/30	6315 ZZDT C3 *
EVMG64 5-2F5/30	6315 ZZDT C3 *
EVMG64 5-1F5/30	6315 ZZDT C3 *
EVMG64 5-0F5/30	6315 ZZDT C3 *
EVMG64 6-3F5/30	6315 ZZDT C3 *
EVMG64 6-2F5/30	6315 ZZDT C3 *
EVMG64 6-1F5/37	6315 ZZDT C3 *
EVMG64 6-0F5/37	6315 ZZDT C3 *
EVMG64 7-3F5/37	6315 ZZDT C3 *
EVMG64 7-2F5/37	6315 ZZDT C3 *
EVMG64 7-1F5/37	6315 ZZDT C3 *

*DT=Two single row deep groove ball bearings matched for paired mounting in a tandem arrangement.

PACKING DRAWING EVM(.)32-45-64

3.11

EVM _ PACKING DRAWING

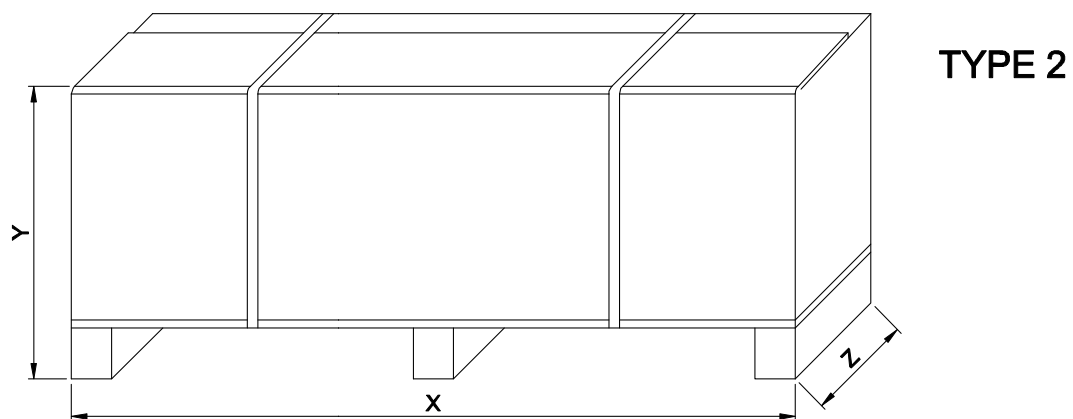
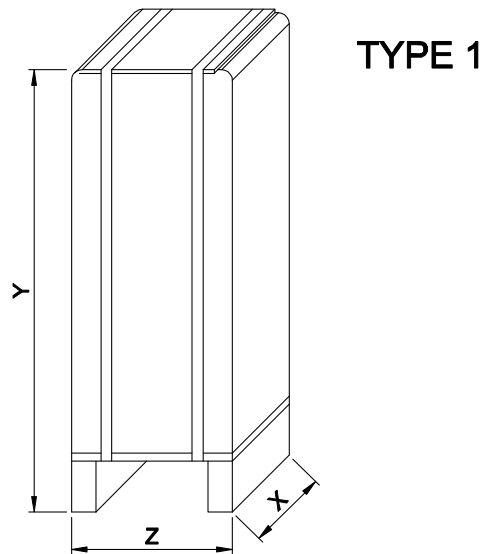

PACKING DATA
EVM(.)32-45-64

Pump type	Pumps						Pumps with motor ~3						
	Packing [mm]			Weight + Packing [kg]		Pack Type	Packing [mm]			Weight + Packing [kg]		Pack Type	
	X	Y	Z	EVM(L)	EVM(G)		X	Y	Z	EVM(L)	EVM(G)		
32	EVM(.)32 1-0F5/2.2	400	780	400	61	56	1	400	1047	400	79	74	1
	EVM(.)32 2-2F5/3.0	400	780	400	63	58	1	400	1047	400	87.5	82.5	1
	EVM(.)32 2-0F5/4.0	400	780	400	63	58	1	400	1047	400	95.1	90.1	1
	EVM(.)32 3-3F5/5.5	400	780	400	79	72	1	400	1047	400	130.6	123.6	1
	EVM(.)32 3-1F5/5.5	400	780	400	79	72	1	400	1047	400	130.6	123.6	1
	EVM(.)32 4-3F5/7.5	400	780	400	82	75	1	400	1047	400	136.4	129.4	1
	EVM(.)32 4-1F5/7.5	400	780	400	82	75	1	400	1047	400	136.4	129.4	1
	EVM(.)32 5-3F5/11	1047	400	400	103	94	1	540	1540	500	207.3	198.3	2
	EVM(.)32 5-0F5/11	1047	400	400	103	94	1	540	1540	500	207.3	198.3	2
	EVM(.)32 6-3F5/11	1047	400	400	106	97	1	540	1540	500	210.3	201.3	2
	EVM(.)32 6-2F5/11	1047	400	400	106	97	1	540	1540	500	210.3	201.3	2
	EVM(.)32 7-3F5/15	1047	400	400	109	100	1	540	1540	500	220.8	211.8	2
	EVM(.)32 7-0F5/15	1047	400	400	109	100	1	540	1540	500	220.8	211.8	2
	EVM(.)32 8-3F5/15	1240	400	400	115	105	1	540	1540	500	223.8	213.8	2
	EVM(.)32 8-2F5/15	1240	400	400	115	105	1	540	1540	500	223.8	213.8	2
	EVM(.)32 9-3F5/18.5	1240	400	400	118	108	1	593	1750	610	232.5	222.5	2
	EVM(.)32 9-0F5/18.5	1240	400	400	118	108	1	593	1750	610	232.5	222.5	2
	EVM(.)32 10-3F5/18.5	1240	400	400	122	111	1	593	1750	610	236.5	225.5	2
	EVM(.)32 10-2F5/18.5	1240	400	400	122	111	1	593	1750	610	236.5	225.5	2
	EVM(.)32 11-3F5/22	1240	400	400	126	115	1	593	1750	610	282	271	2
EVM(.)32 11-0F5/22	1240	400	400	126	115	1	593	1750	610	282	271	2	
EVM(.)32 12-3F5/22	540	1350	400	133	122	2	587	2130	635	346	335	2	
EVM(.)32 13-3F5/30	545	1350	500	143	131	2	587	2130	635	399	387	2	
EVM(.)32 13-0F5/30	545	1350	500	143	131	2	587	2130	635	399	387	2	
EVM(.)32 14-3F5/30	545	1350	500	147	134	2	587	2130	635	403	390	2	
EVM(.)32 14-0F5/30	545	1350	500	147	134	2	587	2130	635	403	390	2	
45	EVM(.)45 1-1F5/3.0	400	780	400	76	69	1	400	1047	400	100.5	93.5	1
	EVM(.)45 1-0F5/4.0	400	780	400	78	71	1	400	1047	400	110.1	106.6	1
	EVM(.)45 2-2F5/5.5	400	780	400	86	79	1	400	1047	400	137.6	131.4	1
	EVM(.)45 2-0F5/7.5	400	780	400	86	79	1	400	1047	400	140.4	133.4	1
	EVM(.)45 3-2F5/11	400	1047	400	106	97	1	1540	540	500	210.3	201.3	2
	EVM(.)45 3-0F5/11	400	1047	400	106	97	1	1540	540	500	210.3	201.3	2
	EVM(.)45 4-2F5/15	400	1047	400	115	105	1	1540	540	500	214.8	204.8	2
	EVM(.)45 4-0F5/15	400	1047	400	115	105	1	1540	540	500	214.8	204.8	2
	EVM(.)45 5-2F5/18.5	400	1240	400	138	126	1	1750	593	610	252.5	240.5	2
	EVM(.)45 5-0F5/18.5	400	1240	400	138	126	1	1750	593	610	252.5	240.5	2
	EVM(.)45 6-2F5/22	400	1240	400	143	130	1	1750	593	610	299	286	2
	EVM(.)45 6-0F5/22	400	1240	400	143	130	1	1750	593	610	299	286	2
	EVM(.)45 7-2F5/30	480	1297	480	149	136	1	2130	587	635	409	396	2
	EVM(.)45 7-0F5/30	480	1297	480	149	136	1	2130	587	635	409	396	2
	EVM(.)45 8-2F5/30	1350	545	500	160	147	2	2130	587	635	416	403	2
	EVM(.)45 8-0F5/30	1350	545	500	160	147	2	2130	587	635	416	403	2
	EVM(.)45 9-2F5/30	1350	545	500	165	151	2	2130	587	635	421	407	2
	EVM(.)45 9-0F5/37	1750	593	610	172	158	2	2130	587	635	435	421	2
EVM(.)45 10-2F5/37	1750	593	610	177	162	2	2130	587	635	440	425	2	
EVM(.)45 10-0F5/37	1750	593	610	177	162	2	2130	587	635	440	425	2	
64	EVM(.)64 1-1F5/4.0	400	780	400	76	69	1	400	1047	400	108.1	101.1	1
	EVM(.)64 1-0F5/5.5	400	780	400	82	75	1	400	1047	400	133.6	126.6	1
	EVM(.)64 2-2F5/7.5	400	780	400	87	79	1	400	1047	400	140.4	133.4	1
	EVM(.)64 2-1F5/11	400	1047	400	100	92	1	1350	545	500	205.3	196.3	2
	EVM(.)64 2-0F5/11	400	1047	400	100	92	1	1350	545	500	205.3	196.3	2
	EVM(.)64 3-3F5/15	400	1047	400	106	97	1	1540	540	500	218.8	209.8	2
	EVM(.)64 3-2F5/15	400	1047	400	106	97	1	1540	540	500	218.8	209.8	2
	EVM(.)64 3-1F5/15	400	1047	400	106	97	1	1540	540	500	218.8	209.8	2
	EVM(.)64 3-0F5/18.5	400	1047	400	106	97	1	1540	540	500	217.5	208.5	2
	EVM(.)64 4-3F5/18.5	400	1047	400	115	105	1	1540	540	500	226.5	216.5	2
	EVM(.)64 4-2F5/18.5	400	1047	400	115	105	1	1540	540	500	226.5	216.5	2
	EVM(.)64 4-1F5/22	400	1047	400	123	112	1	1750	593	610	282	271	2
	EVM(.)64 4-0F5/22	400	1047	400	123	112	1	1750	593	610	282	271	2
	EVM(.)64 5-3F5/30	480	1147	480	138	126	1	1750	593	610	337	325	2
	EVM(.)64 5-2F5/30	480	1147	480	138	126	1	1750	593	610	337	325	2
	EVM(.)64 5-1F5/30	480	1147	480	138	126	1	1750	593	610	337	325	2
	EVM(.)64 5-0F5/30	480	1147	480	138	126	1	1750	593	610	337	325	2
	EVM(.)64 6-3F5/30	480	1297	480	146	134	1	2130	587	635	406	394	2
	EVM(.)64 6-2F5/30	480	1297	480	146	134	1	2130	587	635	406	394	2
	EVM(.)64 6-1F5/37	480	1297	480	146	134	1	2130	587	635	420	408	2
EVM(.)64 6-0F5/37	480	1297	480	146	134	1	2130	587	635	420	408	2	
EVM(.)64 7-3F5/37	480	1297	480	149	136	1	2130	587	635	423	410	2	
EVM(.)64 7-2F5/37	480	1297	480	149	136	1	2130	587	635	423	410	2	
EVM(.)64 7-1F5/37	480	1297	480	149	136	1	2130	587	635	423	410	2	

MOTOR

VERTICAL MULTISTAGE PUMPS

GENERAL

Various regulatory authorities in many countries have introduced or are planning legislation to encourage the manufacture and use of higher efficiency motors, as part of a concerted effort worldwide to reduce energy consumption.

Indeed, the International Electrotechnical Commission (IEC) has introduced a new standards relating to energy efficient motors.

IEC 60034-30 defines new efficiency classes for motors and harmonizes the currently different requirements for induction motor efficiency levels around the world.

On 22 July 2009, **Commission Regulation (EC) N. 640/2009** implementing EcoDesign EUP Directive 2005/32/EC states that in the European Community, with the exception of some special applications, motors shall not be less efficient than the IE3 efficiency level as from 1 January 2015.

In detail:

IE3 by *January 1, 2015* (for motors ≥ 7.5 to 375 kW).

IE3 for all motors by *January 1, 2017* (for motors from 0.75 to 375 kW).

		MOTOR EVMS		MOTOR EVM
Power Source	Frequency	50 Hz		50 Hz
	Phase	Single Phase	Three Phase	Three Phase
	Rotation speed	$\approx 2900 \text{ min}^{-1}$		$\approx 2900 \text{ min}^{-1}$
	Power rating	$0.37 \div 2.2 \text{ kW}$ $0.5 \div 3.0 \text{ HP}$	$0.37 \div 18.5 \text{ kW}$ $0.5 \div 25 \text{ HP}$	$2.2 \div 37 \text{ kW}$ $3.0 \div 50 \text{ HP}$
	Voltage	$230 \pm 10\% \text{ V}$	$230/400 \pm 10\% \text{ V}$ (up to 4kW) $400/690 \pm 10\% \text{ V}$ (above 5.5 kW)	$230/400 \pm 10\% \text{ V}$ (up to 4kW) $400/690 \pm 10\% \text{ V}$ (above 5.5 kW)
Type	Type	Electric - TEFC		Electric - TEFC
	Efficiency Level	from 0.37 up to 2.2 kW	- from 0.37 up to 0.55 kW IE3 above 0.75 kW	IE2 from 2.2 up to 5.5 kW (IE3 on request) IE3 above 7.5 kW
	No' of poles	2		2
	Protection degree	IP 55		IP 55
Others	Insulation Class	F (temperature rise class B)		F (temperature rise class B)
	Thermal Protection	PTC is available for the above 1.5 kW		PTC
	Casing Material	Aluminium		Aluminium
	Flange mount (IEC motor)	IM B14 (up to 4 kW) IM B5 (above 5.5 kW)		IM B14 (up to 4 kW) IM B5 (above 5.5 kW)

NOISE DATA

Coupling Flange Size (MEC)	Power		Noise LpA - dB(A) *
	[kW]	[HP]	
71	0.37	0.5	<70
	0.55	0.75	
80	0.75	1	<70
	1.1	1.5	
90 S	1.5	2	<70
90 L	2.2	3	
100 L	3.0	4	<70
112 M	4.0	5.5	<70
132 S	5.5	7.5	72
	7.5	10	
160 M	11	15	74
	15	20	
160 L	18.5	25	
180 M	22	30	77
200 L	30	40	78
	37	50	

401

TECHNICAL MOTOR DATA EVMS 1-3-5-10-15-20

Single Phase Motor at 50Hz, 2 poles

Motor Coupling Flange Size (MEC)	Power		Capacitor		Load efficiency and power-factor		Full load current [A]	Locked rotor current [A]
	[kW]	[HP]	[μF]	[V]	η %	cos-φ	230 V	230 V
					100%	100%		
71	0.37	0.5	16	400	57.6	0.89	3.1	9.6
71	0.55	0.75	16	400	69.0	0.89	3.9	13.6
80	0.75	1	25	400	65.0	0.95	5.3	28.1
80	1.1	1.5	36	400	74.0	0.97	6.5	26
♦ 90 S	1.5	2	35	400	79.0	0.97	8.8	46
♦ 90 L	2.2	3	40	400	78.0	0.97	12.9	61

♦ Single phase motors manufactured by EBARA

Three Phase Motor at 50Hz, 2 poles

Motor Coupling Flange Size (MEC)	Power		Efficiency	Load efficiency and power-factor				Full load current [A]			Locked rotor current [A]		
	[kW]	[HP]		50%	η %	100%	cos-φ	230 V	400V	690V	230 V	400V	690V
					75%		100%						
71	0.37	0.5	-	58.0	64.0	70.0	0.78	1.7	1	-	8.1	4.7	-
71	0.55	0.75	-	57.0	64.0	71.0	0.77	2.6	1.5	-	12.5	7.2	-
80	0.75	1	IE3	77.8	81.2	82.0	0.78	2.9	1.7	-	26.1	15.1	-
80	1.1	1.5	IE3	78.7	81.7	82.7	0.76	4.2	2.4	-	38.7	22.3	-
90 S	1.5	2	IE3	83.2	84.8	84.2	0.85	5.2	3	-	43.6	25.2	-
90 L	2.2	3	IE3	85.0	86.2	86.5	0.82	8	4.6	-	73.3	42.3	-
100 L	3.0	4	IE3	82.3	85.8	87.1	0.89	9.7	5.6	-	85.4	49.3	-
112 M	4.0	5.5	IE3	86.8	87.8	88.1	0.93	12.1	7	-	116.4	67.2	-
132 S	5.5	7.5	IE3	88.0	88.5	89.2	0.90	-	10	5.8	-	89	51.4
132 S	7.5	10	IE3	88.6	89.2	90.1	0.92	-	13.1	7.6	-	116.6	67.3
160 M	11	15	IE3	87.4	89.8	91.2	0.89	-	19.7	11.4	-	179.3	103.5
160 M	15	20	IE3	91.0	91.3	91.9	0.89	-	26.7	15.4	-	259	149.5
160 L	18.5	25	IE3	91.6	92.8	92.4	0.88	-	33	19.1	-	353.1	203.9

TECHNICAL MOTOR DATA EVM 32-45-64

IE2 Three Phase Motor at 50Hz, 2 poles

Motor Coupling Flange Size (MEC)	Power		Efficiency	Load efficiency and power-factor				Full load current [A]			Locked rotor current [A]		
	[kW]	[HP]		50%	η % 75%	100%	cos- ϕ 100%	230 V	400V	690V	230 V	400V	690V
90 L	2.2	3	IE2	82.5	84.0	84.0	0.85	7.6	4.4	-	64.8	37.4	-
100 L	3.0	4	IE2	84.1	85.8	85.5	0.84	10.2	5.9	-	81.8	47.2	-
112 M	4.0	5.5	IE2	85.2	86.4	86.1	0.86	13.5	7.8	-	110.9	64.0	-
132 S	5.5	7.5	IE2	85.8	87.4	87.3	0.88	-	10.4	6.0	-	83.2	48.0

IE3 Three Phase Motor at 50Hz, 2 poles

Motor Coupling Flange Size (MEC)	Power		Efficiency	Load efficiency and power-factor				Full load current [A]			Locked rotor current [A]		
	[kW]	[HP]		50%	η % 75%	100%	cos- ϕ 100%	230 V	400V	690V	230 V	400V	690V
132 S	7.5	10	IE3	88.6	89.2	90.1	0.92	-	13.1	7.6	-	116.6	67.3
160 M	11	15	IE3	87.4	89.8	91.2	0.89	-	19.7	11.4	-	179.3	103.5
160 M	15	20	IE3	91.0	91.3	91.9	0.89	-	26.7	15.4	-	259	149.5
160 L	18.5	25	IE3	91.6	92.8	92.4	0.88	-	33	19.1	-	353.1	203.9
180 M	22	30	IE3	92.3	92.9	92.9	0.90	-	38	22	-	361	209
200 L	30	40	IE3	92.8	93.9	94.0	0.89	-	51.8	30	-	459	270
200 L	37	50	IE3	93.0	93.9	93.8	0.90	-	62.5	36	-	496	288

