



**EBARA**



	Page
<b>- SPECIFICATIONS</b>	<b>200</b>
SELECTION CHART	201
TYPE KEY AND CURVE SPECIFICATIONS	202
PERFORMANCE CURVE CDX 70	204
PERFORMANCE CURVE CDX 90	205
PERFORMANCE CURVE CDX 120	206
PERFORMANCE CURVE CDX 200	207
<b>- CONSTRUCTIONS</b>	<b>300</b>
SECTIONAL VIEW CDX 70/05-70/07-90/10	300
SECTIONAL VIEW CDX 120/07-120/20	301
SECTIONAL VIEW CDX 120/12-200/12-200/20-200/25	302
MECHANICAL SEAL	303
THERMAL INSULATION	304
<b>- DIMENSIONS AND WEIGHT</b>	<b>400</b>
PUMP	400
PACKING	401
<b>- TECHNICAL DATA</b>	<b>500</b>
MOTOR DATA	500
NOISE DATA	500

**SELECTION CHART**

50Hz

Rev. N

<b>PUMP</b>		
Liquid Handled	Type of liquid	Clean water
	Temperature [°C]	min. -5 max. +60 (CDX 70/05-70/07-90/10) max. +90 max. +110 (H-HS-HW-HSW) max. +120 (E)
Maximum working pressure	[MPa]	0.8
Construction	Impeller	Closed centrifugal type
	Shaft seal type	Mechanical seal
	Bearing	Sealed ball bearing
Pipe Connection	Suction	from G 1¼ to G 1½ UNI ISO 228-1
	Discharge	G 1 UNI ISO 228-1
Material	Casing	EN 1.4301 (AISI 304) - (AISI 316 only for "L" version)
	Impeller	EN 1.4301 (AISI 304) - (AISI 316 only for "L" version)
	Casing cover	EN 1.4301 (AISI 304) - (AISI 316 only for "L" version)
	Shaft seal	Ceramic/Carbon/NBR (for special versions see page 303)
	Shaft	AISI 303 / AISI 316 (Wet extension)
	Bracket	Aluminium
Applicable standard of test		ISO 9906 – Annex A

<b>MOTOR</b>		
Type	Electric - TEFC	
	Single Phase	Three Phase
Efficiency level (Reg. 640/2009)	-	IE1 from 0.37 kW up to 0.55 kW IE2 from 0.75 kW up to 1.8 kW IE3 from 0.75 kW up to 1.8 kW
No. of Poles	2	
Rotation speed [min <sup>-1</sup> ]	≈ 2800	
Insulation Class	F	
Protection degree (CEI EN 60034-5)	IP 55	
Power rating	[kW]	0.37 ÷ 1.5
	[HP]	0.5 ÷ 2
Frequency [Hz]	50	
Voltage [V]	230 ±10%	230/400 ±10%
Capacitor	Built in	-
Over load protection	Built in	Provided by the user
Casing material	Aluminium	
Base material/motor support	Aluminium	
Dimensions of cable entry	PG11 - PG13.5 - M16x1.5 – M20x1.5 (see dimensions page 400)	

## SELECTION CHART

50Hz

Rev. N

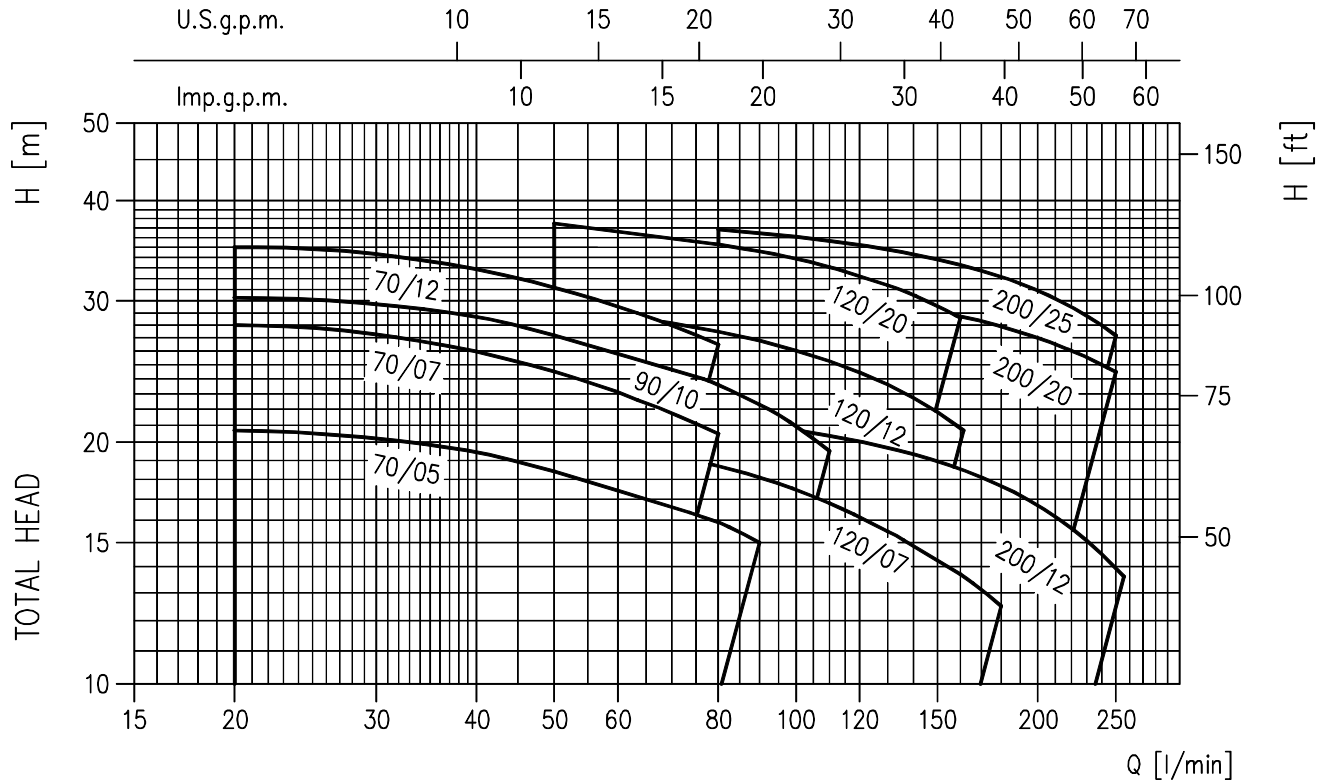

Pump type		Power		Q=Capacity												
Single Phase	Three Phase	[kW]	[HP]	l/min	0	20	50	80	90	110	130	160	180	210	250	
				m <sup>3</sup> /h	0	1,2	3	4,8	5,4	6,6	7,8	9,6	10,8	12,6	15	
				H=Total manometric head in meters												
CDXM 70/05	CDX 70/05	0,37	0,5	22	20,7	18,4	15,9	15	-	-	-	-	-	-	-	
CDXM 70/07	CDX 70/07	0,55	0,75	30	28	24,5	20,5	-	-	-	-	-	-	-	-	
CDXM 90/10	CDX 90/10	0,75	1	32	30,3	27,2	23,6	22,3	19,5	-	-	-	-	-	-	
CDXM 120/07	CDX 120/07	0,55	0,75	22,5	-	20,5	18,7	18,1	16,8	15,5	13,7	12,5	-	-	-	
CDXM 120/12	CDX 120/12	0,9	1,2	31,2	-	29,3	27,5	26,8	25,2	23,6	21	-	-	-	-	
CDXM 120/20	CDX 120/20	1,5	2	40,5	-	37,5	35,3	34,6	33,1	31,4	28,6	-	-	-	-	
CDXM 200/12	CDX 200/12	0,9	1,2	22,8	-	-	21,3	21	20,4	19,7	18,5	17,6	16	14	-	
CDXM 200/20	CDX 200/20	1,5	2	33	-	-	31,5	31,2	30,6	30	28,7	27,9	26,5	24,5	-	
-	CDX 200/25	1,8	2,5	39,4	-	-	36,8	26,5	35,6	34,7	33,3	32	30	27,2	-	

**TYPE KEY**

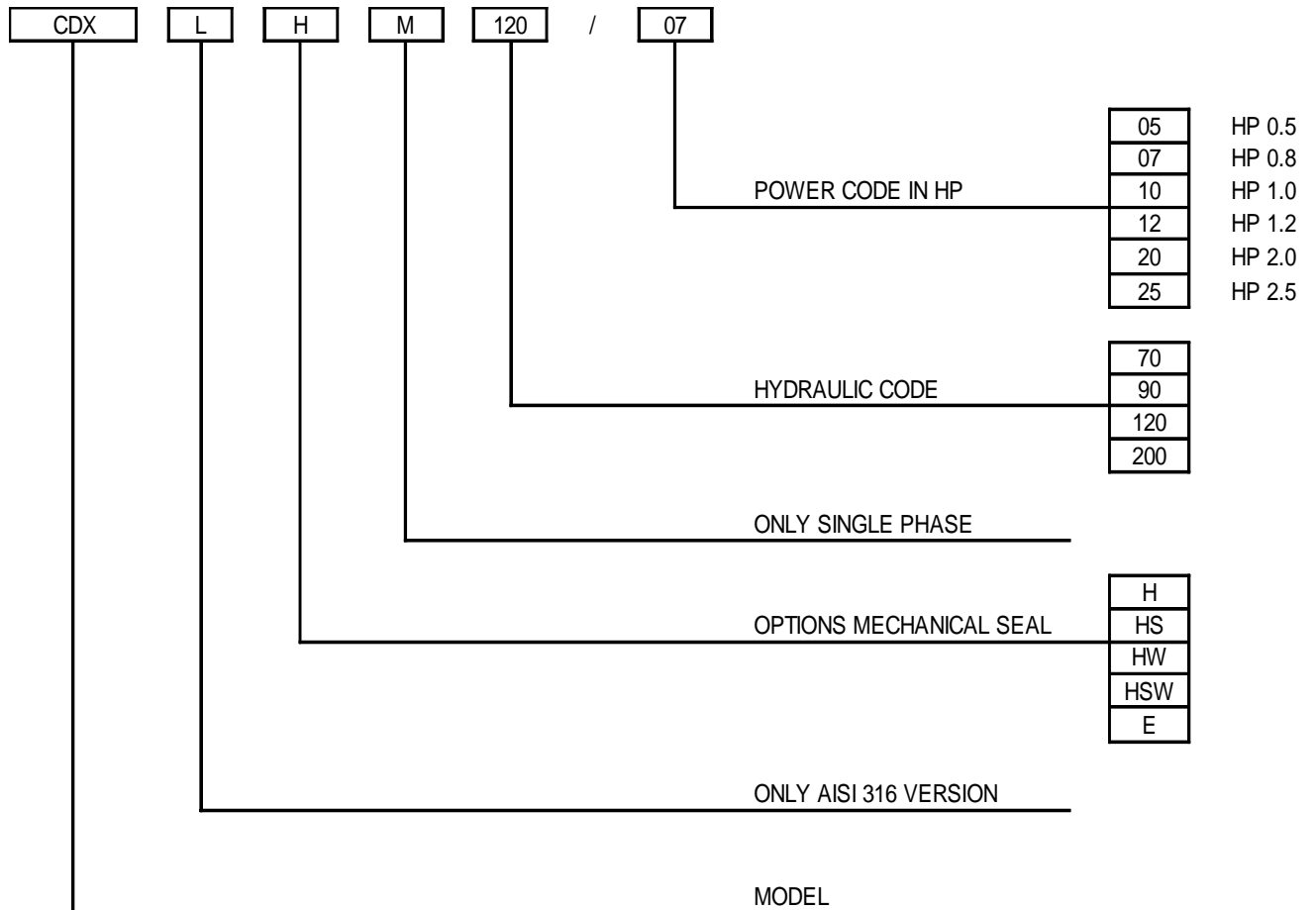

### PERFORMANCE CURVE SPECIFICATIONS

The specifications below qualify the curves shown on the following pages.

Tolerances according to ISO 9906 Annex A

The curves refer to effective speed of asynchronous motors at 50 Hz

Measurements were carried out with clean water at 20°C of temperature and with a kinematic viscosity of  $\nu = 1 \text{ mm}^2/\text{s}$  (1 cSt)

The NPSH curve is an average curve obtained in the same conditions of performance curves.

The continuous curves indicate the recommended working range. The dotted curve is only a guide.

In order to avoid the risk of over-heating, the pumps should not be used at a flow rate below 10% of best efficiency point.

Symbols explanation:

- Q = volume flow rate
- H = total head
- $P_2$  = pump power input (shaft power)
- $\eta$  = pump efficiency
- NPSH = net positive suction head required by the pump
- MEI = minimum efficiency index

The minimum efficiency index (MEI) is a measure of the quality of a pump size in respect to its mean efficiency. The minimum efficiency index is based on the hydraulic efficiency and on the head at the best efficiency point.

The efficiency of a pump with trimmed impeller is usually lower than that of a pump with the full impeller diameter. The trimming of the impeller will adapt the pump to a fixed duty point, leading to reduced energy consumption. The minimum efficiency index (MEI) is based on the full impeller diameter.

The operation of these water pumps with variable duty points may be more efficient and economic when controlled, for example, by the use of a variable speed drive that matches the pump duty to the system.

MEI = 0.4 for ESCC 2900 rpm

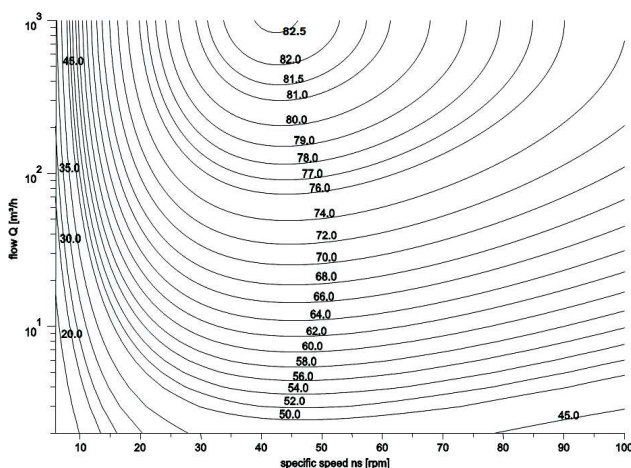

MEI = 0.7 for ESCC 2900rpm

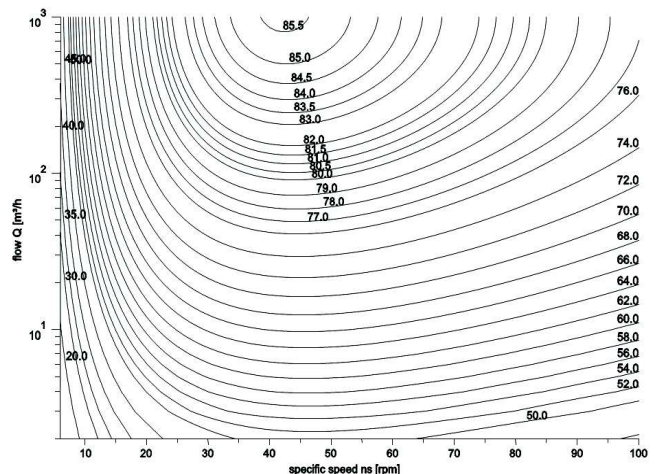

CDX 70/05 (0.37 kW) - Impeller diameter = 132 mm  
 CDX 70/07 (0.55 kW) - Impeller diameter = 157 mm

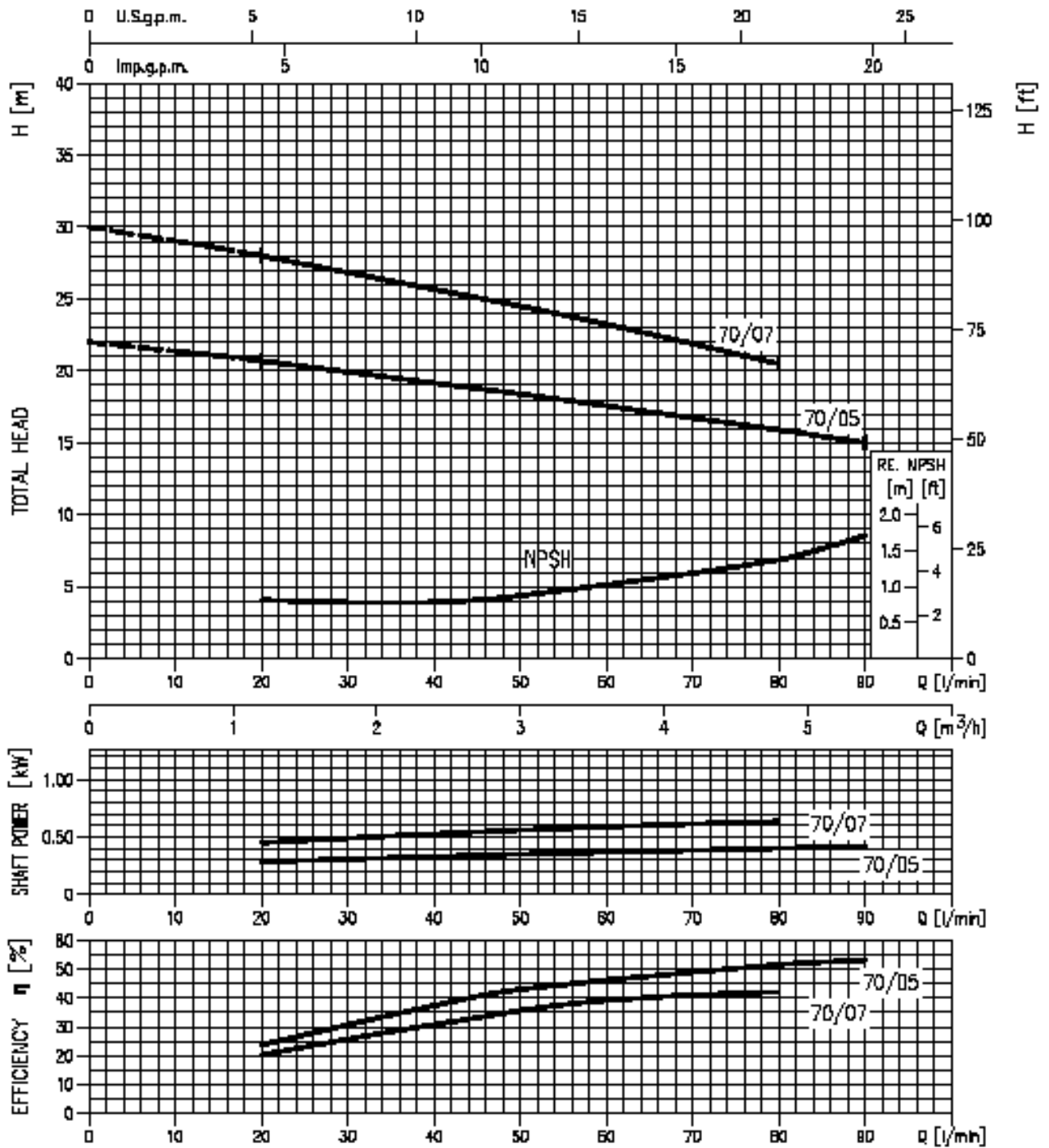

Rotation speed  $\approx 2800 \text{ min}^{-1}$   
 Test standard: ISO 9906 – Annex A

CDX 90/10 (0.75 kW) MEI > 0.50 - Impeller diameter = 157 mm

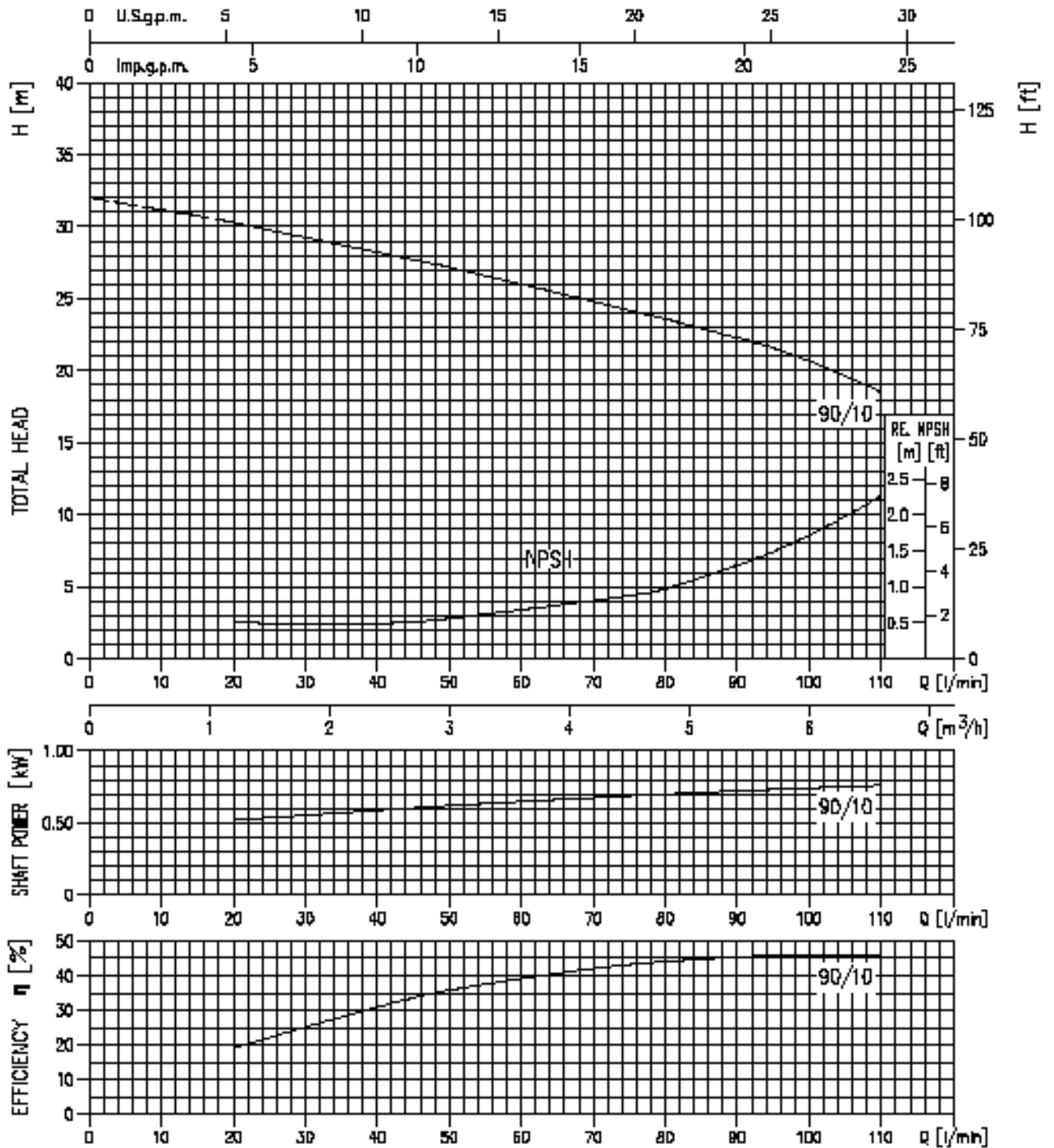

Rotation speed  $\approx 2800 \text{ min}^{-1}$   
 Test standard: ISO 9906 – Annex A



PERFORMANCE CURVE

50Hz

Rev. N

CDX 120/07 (0.55 kW) MEI > 0.50 - Impeller diameter = 132 mm  
 CDX 120/12 (0.90 kW) MEI > 0.40 - Impeller diameter = 157 mm  
 CDX 120/20 (1.50 kW) MEI > 0.40 - Impeller diameter = 176 mm

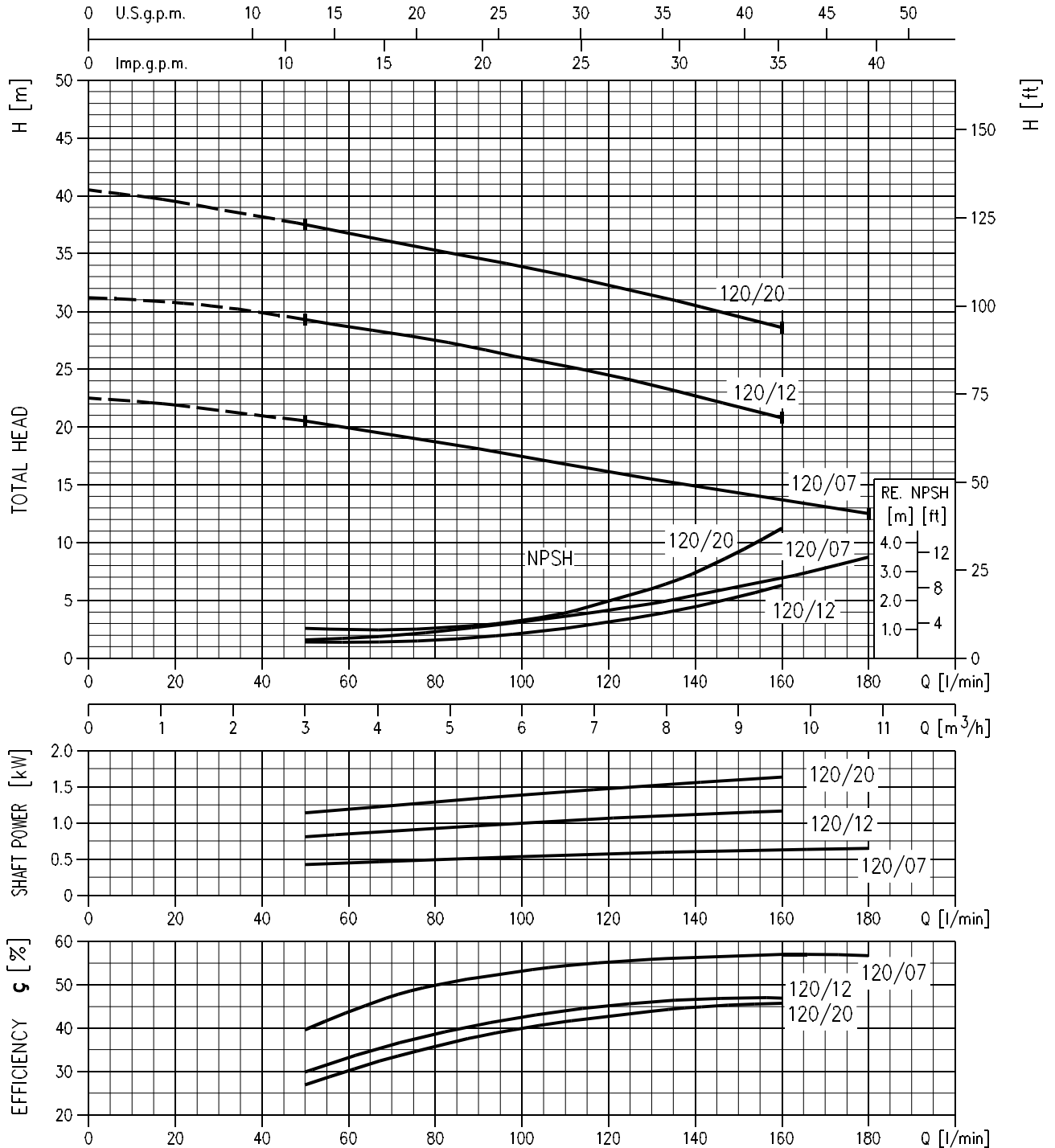

Rotation speed  $\approx 2800 \text{ min}^{-1}$   
 Test standard: ISO 9906 – Annex A

PERFORMANCE CURVE

50Hz

Rev. N

CDX 200/12 (0.90 kW) MEI > 0.50 - Impeller diameter = 132 mm  
 CDX 200/20 (1.50 kW) MEI > 0.60 - Impeller diameter = 157 mm  
 CDX 200/25 (1.80 kW) MEI > 0.40 - Impeller diameter = 176 mm

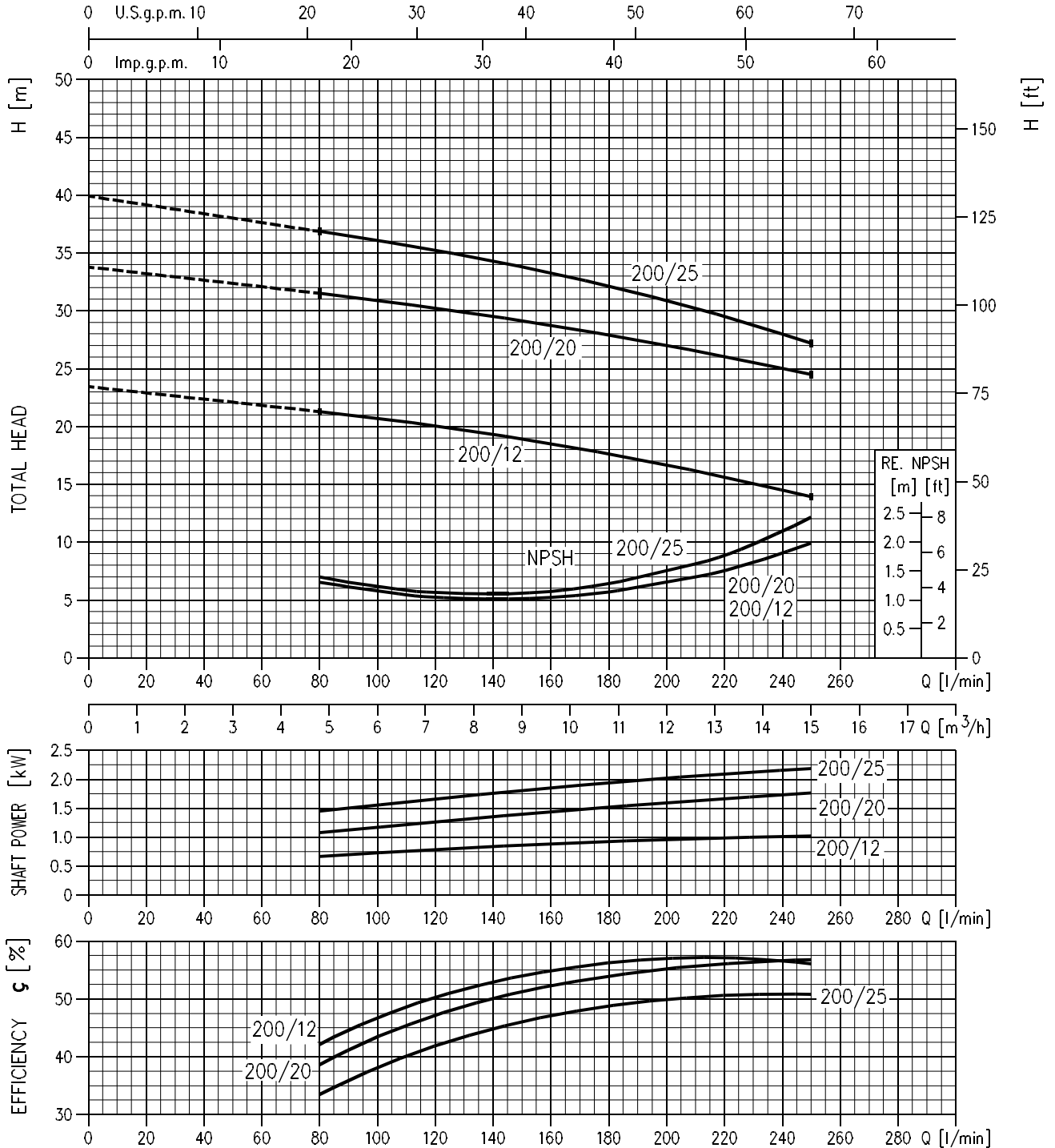

Rotation speed  $\approx 2800 \text{ min}^{-1}$   
 Test standard: ISO 9906 – Annex A

SECTIONAL VIEW CDX 70/05 - 70/07 - 90/10

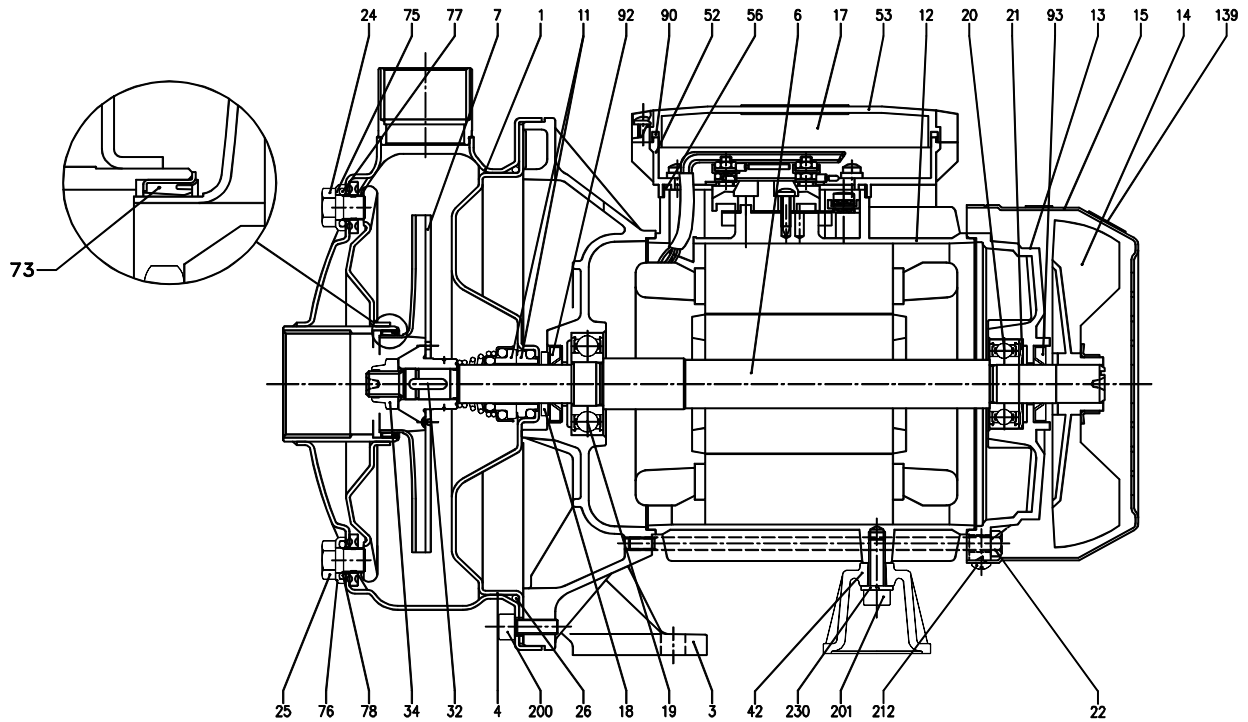

N°	PART NAME	MATERIAL	Q.TY	N°	PART NAME	MATERIAL	Q.TY
1	Casing	AISI 304 / AISI 316 [5]	1	25	Drain plug	AISI 303 / AISI 316 [5]	1
3	Motor bracket	Aluminium	1	26	O-ring [3]	NBR	1
4	Casing cover	AISI 304 / AISI 316 [5]	1	32	Key	AISI 316	1
6	Shaft with rotor	AISI 303 / AISI 316 [5] (Wet extension)	1	34	Impeller nut	AISI 304 / AISI 316 [5]	1
7	Impeller	AISI 304 / AISI 316 [5]	1	42	Motor support	Aluminium	1
11	Mechanical seal [3]	Carbon/Ceramic/NBR	1	52	Terminal box [1]	ABS class V-0	1
12	Motor frame with stator	-	1	53	Terminal box cover [1]	ABS class V-0	1
13	Motor cover	Aluminium	1	56	Box gasket	NBR	1
14	Fan	PA	1	73	Casing ring [4]	NBR	1
15	Fan cover	Fe P04 Zincate	1	75	Washer	AISI 304	1
16	Terminal board	-	1	76	Washer	AISI 304	1
17	Terminal box cover [2]	Aluminium	1	77	O-ring [3]	NBR	1
18	Splash ring	NBR	1	78	O-ring [3]	NBR	1
19	Pump side ball bearing	-	1	90	Terminal box cover gasket [1]	NBR	1
20	Fan side ball bearing	-	1	92	Lip seal	-	1
21	Adjusting ring	Steel C70	1	93	Lip seal	-	1
22	Tie rod	Fe 420 Zincate	4	110	Protector [1]	-	1
23	Capacitor [1]	-	1	200	Screw	Stainless steel A2 UNI7323	8
24	Priming plug	AISI 303 / AISI 316 [5]	1				

- [1] Only for single phase
- [2] Only for three phase
- [3] FPM for CDX H-HS-HW-HSW  
EPDM for CDX E
- [4] NBR for CDX 70/05, 70/07, 90/10  
FPM for CDX H-HS-HW-HSW 70/05, 70/07, 90/10
- [5] Only for "L" version

### SECTIONAL VIEW CDX 120/07 - 120/20

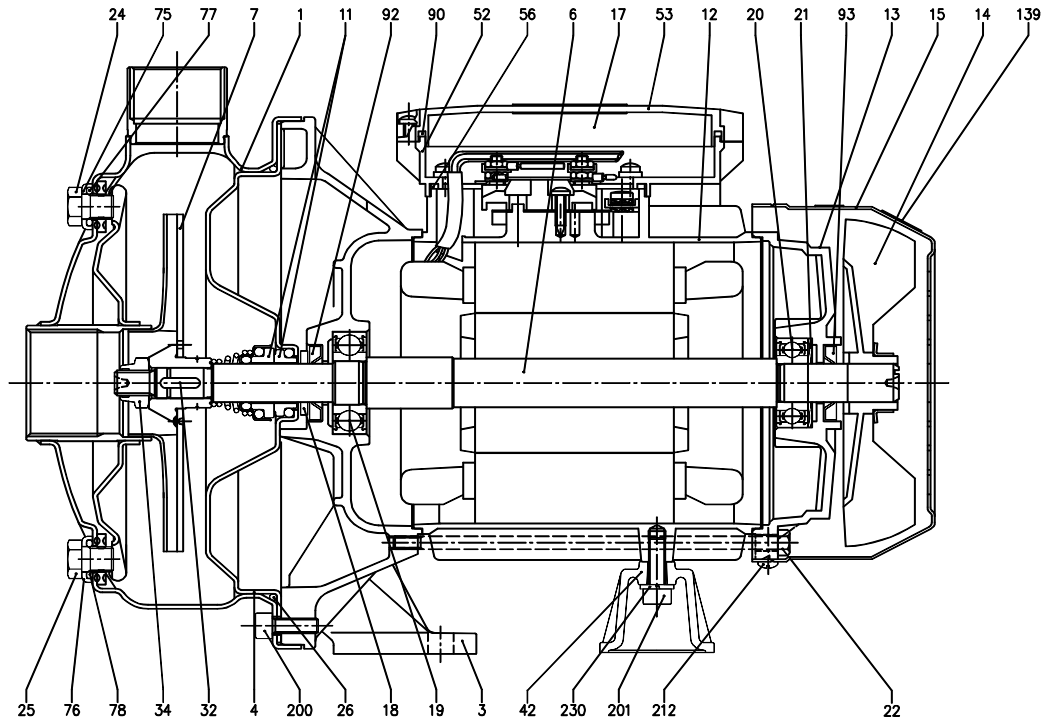

N°	PART NAME	MATERIAL	Q.TY	N°	PART NAME	MATERIAL	Q.TY
1	Casing	AISI 304 / AISI 316 [5]	1	25	Drain plug	AISI 303 / AISI 316 [5]	1
3	Motor bracket	Aluminium	1	26	O-ring [3]	NBR	1
4	Casing cover	AISI 304 / AISI 316 [5]	1	32	Key	AISI 316	1
6	Shaft with rotor	AISI 303 / AISI 316(Wet extension)	1	34	Impeller nut	AISI 304 / AISI 316 [5]	1
7	Impeller	AISI 304 / AISI 316 [5]	1	42	Motor support	Aluminium	1
11	Mechanical seal [3]	Carbon/Ceramic/NBR	1	52	Terminal box [1]	ABS class V-0	1
12	Motor frame with stator	-	1	53	Terminal box cover [1]	ABS class V-0	1
13	Motor cover	Aluminium	1	56	Box gasket	NBR	1
14	Fan	PA	1	73	Casing ring	-	1
15	Fan cover	Fe P04 Zincate	1	75	Washer	AISI 304	1
16	Terminal board	-	1	76	Washer	AISI 304	1
17	Terminal box cover [2]	Aluminium	1	77	O-ring [3]	NBR	1
18	Splash ring	NBR	1	78	O-ring [3]	NBR	1
19	Pump side ball bearing	-	1	90	Terminal box cover gasket [1]	NBR	1
20	Fan side ball bearing	-	1	92	Lip seal	-	1
21	Adjusting ring	Steel C70	1	93	Lip seal	-	1
22	Tie rod	Fe 420 Zincate	4	110	Protector [1]	-	1
23	Capacitor [1]	-	1	200	Screw	Stainless steel A2 UNI7323	8
24	Priming plug	AISI 303 / AISI 316 [5]	1				

[1] Only for single phase

[2] Only for three phase

[3] FPM for CDX H-HS-HW-HSW  
EPDM for CDX E

[5] Only for "L" version

### SECTIONAL VIEW CDX 120/12 - 200/12 - 200/20 - 200/25

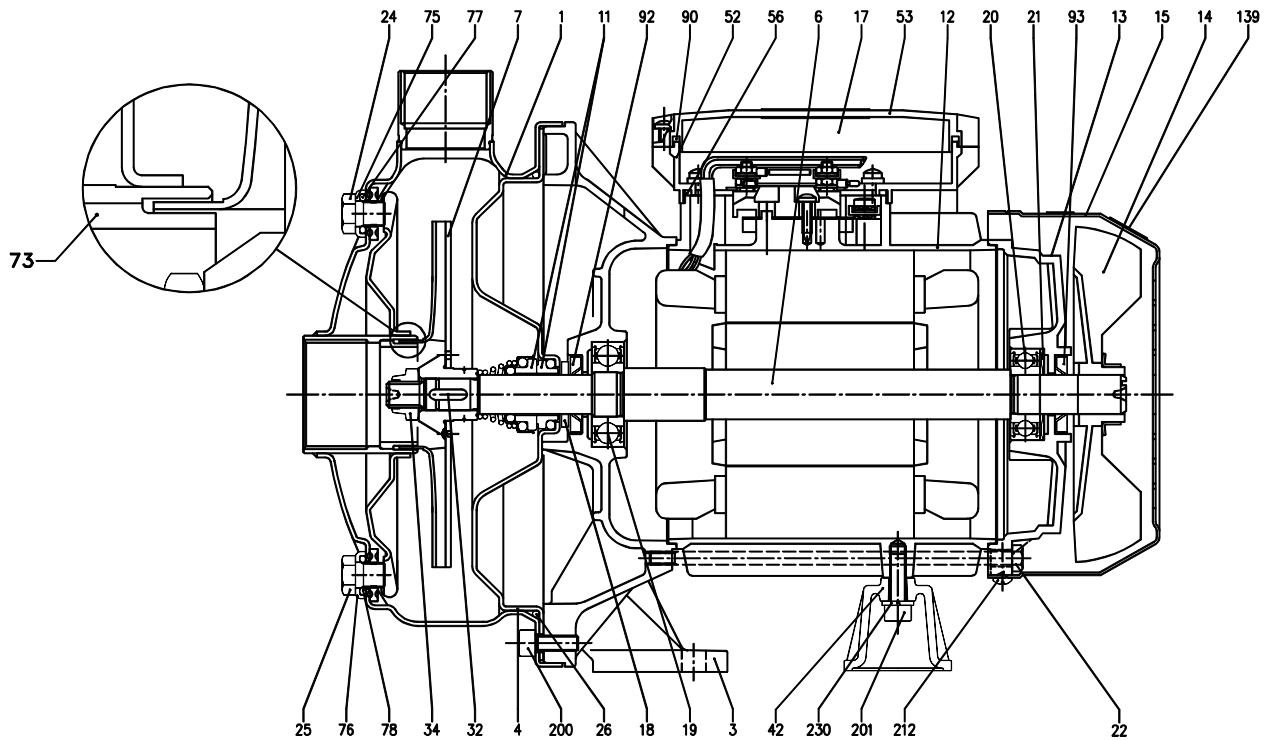

N°	PART NAME	MATERIAL	Q.TY	N°	PART NAME	MATERIAL	Q.TY
1	Casing	AISI 304 / AISI 316 [5]	1	25	Drain plug	AISI 304 / AISI 316 [5]	1
3	Motor bracket	Aluminium	1	26	O-ring [3]	NBR	1
4	Casing cover	AISI 304 / AISI 316 [5]	1	32	Key	AISI 316	1
6	Shaft with rotor	AISI 303 / AISI 316 [5] (Wet extension)	1	34	Impeller nut	AISI 304 / AISI 316 [5]	1
7	Impeller	AISI 304 / AISI 316 [5]	1	42	Motor support	Aluminium	1
11	Mechanical seal [3]	Carbon/Ceramic/NBR	1	52	Terminal box [1]	ABS class V-0	1
12	Motor frame with stator	-	1	53	Terminal box cover [1]	ABS class V-0	1
13	Motor cover	Aluminium	1	56	Box gasket	NBR	1
14	Fan	PA	1	73	Double ring	AISI 304 / AISI 316 [5]	1
15	Fan cover	Fe P04 Zincate	1	75	Washer	AISI 304	1
16	Terminal board	-	1	76	Washer	AISI 304	1
17	Terminal box cover [2]	Aluminium	1	77	O-ring [3]	NBR	1
18	Splash ring	NBR	1	78	O-ring [3]	NBR	1
19	Pump side ball bearing	-	1	90	Terminal box cover gasket [1]	NBR	1
20	Fan side ball bearing	-	1	92	Lip seal	-	1
21	Adjusting ring	Steel C70	1	93	Lip seal	-	1
22	Tie rod	Fe 420 Zincate	4	110	Protector [1]	-	1
23	Capacitor [1]	-	1	200	Screw	Stainless steel A2 UNI7323	8
24	Priming plug	AISI 303 / AISI 316 [5]	1				

- [1] Only for single phase
- [2] Only for three phase
- [3] FPM for CDX H-HS-HW-HSW  
EPDM for CDX E
- [5] Only for "L" version

MECHANICAL SEAL

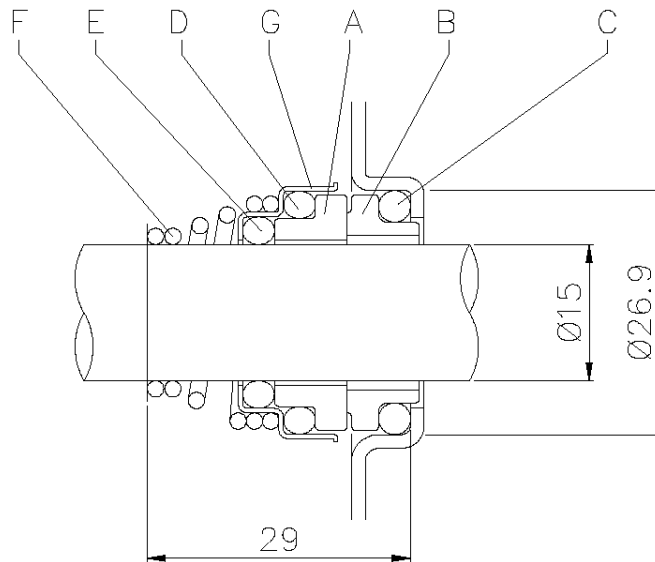

REF	PART NAME	Standard version (CDX)	MATERIAL				
			(CDXH)	(CDXHS)	Optional (CDXHW)	(CDXHSW)	(CDXE)
A	Rotary seal ring	Ceramic	Ceramic	Silicon carbide	Tungsten carbide	Silicon carbide	Ceramic
B	Stationary seal ring	Carbon graphite	Carbon graphite	Silicon carbide	Tungsten carbide	Tungsten carbide	Carbon graphite
C	O Ring	NBR	FPM	FPM	FPM	FPM	EPDM
D	O Ring	NBR	FPM	FPM	FPM	FPM	EPDM
E	O Ring	NBR	FPM	FPM	FPM	FPM	EPDM
F	Self driving spring	AISI 316	AISI 316	AISI 316	AISI 316	AISI 316	AISI 316
G	Frame	AISI 304	AISI 304	AISI 316	AISI 316	AISI 316	AISI 316

BEARINGS

Pump type		Ball Bearing			
Single Phase	Three Phase	Pump side	(*)		
			Pump side	Fan side	
CDXM 70/05	CDX 70/05	6203 2RSH	6203-ZZ C3	6202 2RSH	6202-ZZ C3
CDXM 70/07	CDX 70/07	6203 2RSH	6203-ZZ C3	6202 2RSH	6202-ZZ C3
CDXM 90/10	CDX 90/10	6203 2RSH	6203-ZZ C3	6202 2RSH	6202-ZZ C3
CDXM 120/07	CDX 120/07	6203 2RSH	6203-ZZ C3	6202 2RSH	6202-ZZ C3
CDXM 120/12	CDX 120/12	6203 2RSH	6203-ZZ C3	6202 2RSH	6202-ZZ C3
CDXM 120/20	CDX 120/20	6204 2RSH	6204-ZZ C3	6203 2RSH	6203-ZZ C3
CDXM 200/12	CDX 200/12	6203 2RSH	6203-ZZ C3	6202 2RSH	6202-ZZ C3
CDXM 200/20	CDX 200/20	6204 2RSH	6204-ZZ C3	6203 2RSH	6203-ZZ C3
-	CDX 200/25	6204 2RSH	6204-ZZ C3	6203 2RSH	6203-ZZ C3

(\*) Only for IE3 Motors

**THERMAL INSULATION**

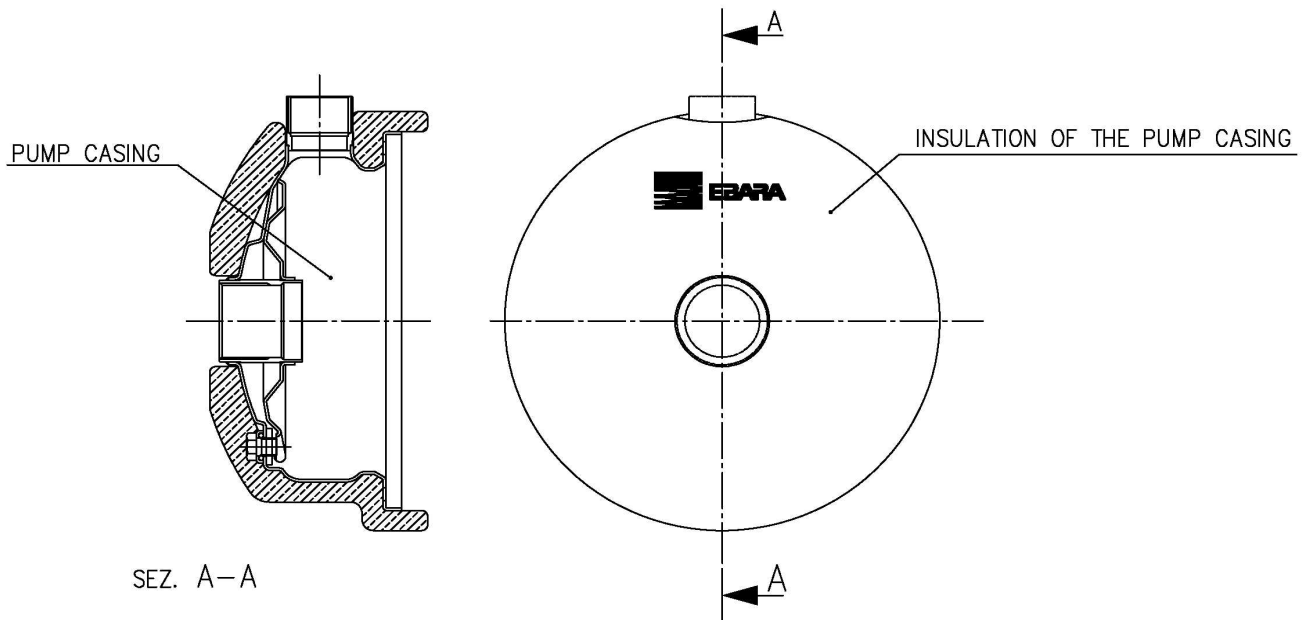

Pump type	INSULATION OF THE PUMP CASING
CDX 70/05	ON REQUEST
CDX 70/07	
CDX 90/10	
CDX 120/07	
CDX 120/12	
CDX 120/20	
CDX 200/12	
CDX 200/20	
CDX 200/25	

### PUMP

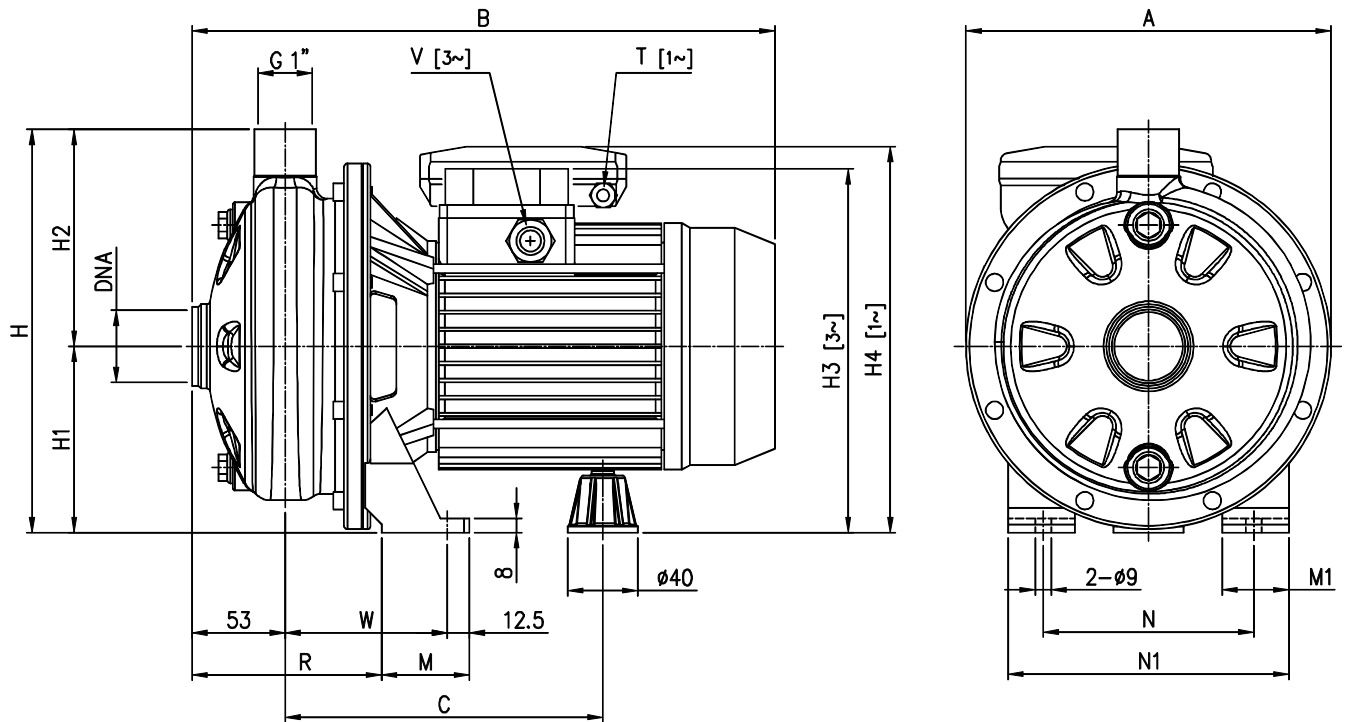

Pump type	Dimensions [mm]																				Weight [kgf]			
	A	B			C	H	H1	H2	H3	H4	M	M1	N	N1	R	T	V			W	DNA	[1~]	[3~]	[*]
CDXM CDX	[1~]	[3~]	[*]	[3~]				[3~]	[1~]						[1~]	[3~]	[*]	[3~]						
70/05	208	321	320	-	181	229,5	106	123,5	207	216	50	38	120	160	108	PG11	PG11	-	92,5	G1 1/4	8,3	8,3	-	
70/07	208	321	320	-	181	229,5	106	123,5	207	216	50	38	120	160	108	PG11	PG11	-	92,5	G1 1/4	9,8	9,7	-	
90/10	208	321	320	320	181	229,5	106	123,5	207	216	50	38	120	160	108	PG11	PG11	M16x1.5	92,5	G1 1/4	11	11	11	
120/07	208	321	320	-	181	229,5	106	123,5	207	216	50	38	120	160	108	PG11	PG11	-	92,5	G1 1/4	9,6	9,5	-	
120/12	208	321	332	332	181	229,5	106	123,5	207	235	50	38	120	160	108	PG11	PG11	M16x1.5	92,5	G1 1/4	11,8	12,4	12,4	
120/20	232	346,5	359	371,5	198,5	250	118	132	237	248,5	55	40	140	180	105,5	PG13.5	PG11	M20x1.5	95	G1 1/4	16,5	17,2	18,1	
200/12	208	321	332	332	181	229,5	106	123,5	207	235	50	38	120	160	108	PG13.5	PG11	M16x1.5	92,5	G1 1/2	11,4	12,2	12,2	
200/20	208	346,5	359	371,5	198,5	229,5	106	123,5	225	236,5	55	40	140	180	105,5	PG13.5	PG11	M20x1.5	95	G1 1/2	15,3	16,1	17	
200/25	232	-	359	371,5	198,5	250	118	132	237	-	55	40	140	180	105,5	-	PG11	M20x1.5	95	G1 1/2	-	15,9	16,8	

[1~] Single phase  
 [3~] Three phase  
 (\*) Only for IE3 Motors



### PACKING

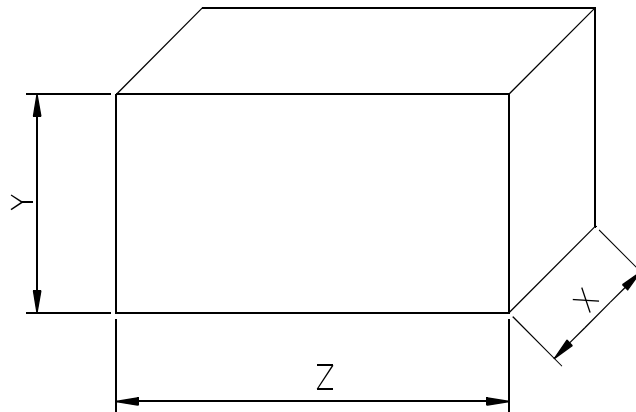

Pump Type		Packing [mm]									Weight [kgf]		
Single Phase	Three Phase	X			Y			Z			[1~]	[3~]	(*) [3~]
		[1~]	[3~]	(*) [3~]	[1~]	[3~]	(*) [3~]	[1~]	[3~]	(*) [3~]			
CDXM 70/05	CDX 70/05	247	247	-	289	289	-	402	402	-	9	9	-
CDXM 70/07	CDX 70/07	247	247	-	289	289	-	402	402	-	10,4	10,4	-
CDXM 90/10	CDX 90/10	247	247	247	289	289	289	402	402	402	11,7	11,6	11,6
CDXM 120/07	CDX 120/07	247	247	-	289	289	-	402	402	-	10,2	10,4	-
CDXM 120/12	CDX 120/12	244	244	244	308	308	308	452	452	452	12,5	13,2	13,2
CDXM 120/20	CDX 120/20	244	244	244	308	308	308	452	452	452	17,2	18	18,9
CDXM 200/12	CDX 200/12	244	244	244	308	308	308	452	452	452	12,1	12,9	12,9
CDXM 200/20	CDX 200/20	244	244	244	308	308	308	452	452	452	16	16,8	17,7
-	CDX 200/25	-	244	244	-	308	308	-	452	452	-	16,7	17,6

[1~] Single phase

[3~] Three phase

(\*) Only for IE3 Motors

### MOTOR DATA

Pump type		Power		Efficiency		Capacitor		Efficiency (% load)			Input [kW]		Full load current [A]			Locked rotor current [A]		
Single Phase	Three Phase	[kW]	[HP]	Single Phase	Three Phase	Single Phase [μF]	[V]	Three phase η %			Single Phase	Three Phase	Single Phase	Three Phase	Single Phase	Three Phase	Single Phase	Three Phase
								50%	75%	100%	Phase	Phase	230 V	230 V	400 V	230 V	230 V	400 V
CDXM 70/05	CDX 70/05	0,37	0,5	-	-	12,5	450	-	-	-	0,75	0,68	3,4	2,4	1,4	10,1	11,0	6,15
CDXM 70/07	CDX 70/07	0,55	0,75	-	-	16	450	-	-	-	1,1	1,0	5,0	3,5	2,0	16,1	17,0	9,7
CDXM 90/10	CDX 90/10	0,75	1,0	-	IE2	20	450	77,2	80,9	81,3	1,2	1,05	5,6	3,3	1,9	22,7	22,0	12,9
-	CDX 90/10	0,75	1,0	-	IE3	-	-	80,9	82,3	82,1	-	0,91	-	3,0	1,7	-	19,7	11,4
CDXM 120/07	CDX 120/07	0,55	0,75	-	-	16	450	-	-	-	1,0	1,0	4,6	3,2	1,85	16,1	17,0	9,7
CDXM 120/12	CDX 120/12	0,9	1,2	-	IE2	31,5	450	79,0	81,7	81,6	1,6	1,45	6,9	4,5	2,6	25,0	31,0	17,8
-	CDX 120/12	0,9	1,2	-	IE3	-	-	81,7	83,1	82,4	-	1,34	-	4,3	2,5	-	28,8	16,6
CDXM 120/20	CDX 120/20	1,5	2,0	-	IE2	40	450	80,3	83,4	83,8	2,1	2,09	9,3	7,0	4,0	43,0	34,3	20,0
-	CDX 120/20	1,5	2,0	-	IE3	-	-	84,2	86,8	86,9	-	2,01	-	7,1	4,1	-	66,6	38,4
CDXM 200/12	CDX 200/12	0,9	1,2	-	IE2	31,5	450	79,0	81,7	81,6	1,4	1,35	6,3	4,3	2,5	25,0	31,0	17,8
-	CDX 200/12	0,9	1,2	-	IE3	-	-	81,7	83,1	82,4	-	1,34	-	4,3	2,5	-	28,8	16,6
CDXM 200/20	CDX 200/20	1,5	2,0	-	IE2	40	450	80,3	83,4	83,8	2,3	2,22	10,2	7,4	4,3	43,0	34,3	20,0
-	CDX 200/20	1,5	2,0	-	IE3	-	-	84,2	86,8	86,9	-	2,01	-	7,1	4,1	-	66,6	38,4
-	CDX 200/25	1,8	2,5	-	IE2	-	-	83,0	84,4	83,8	-	2,87	-	8,7	5,0	-	59,0	34,3
-	CDX 200/25	1,8	2,5	-	IE3	-	-	86,2	87,0	86,0	-	2,55	-	8,2	4,7	-	66,6	38,43

### NOISE DATA

Pump type		Power		L <sub>PA</sub> - dB(A) *
Single Phase	Three Phase	[kW]	[HP]	
CDXM 70/05	CDX 70/05	0,37	0,5	61
CDXM 70/07	CDX 70/07	0,55	0,75	62
CDXM 90/10	CDX 90/10	0,75	1,0	
CDXM 120/07	CDX 120/07	0,55	0,75	64
CDXM 120/12	CDX 120/12	0,9	1,2	
CDXM 120/20	CDX 120/20	1,5	2,0	64
CDXM 200/12	CDX 200/12	0,9	1,2	62
CDXM 200/20	CDX 200/20	1,5	2,0	64
-	CDX 200/25	1,8	2,5	65

\* Mean value of several measures at 1m distance around the pump.  
Tolerance ± 2.5 dB.

