



Units with two horizontal self-priming single impeller pumps with cast iron hydraulic parts.

### PUMP FEATURES

#### FIELD OF USE

- Maximum working pressure: 6 bar (AGA 1.00)  
10 bar for the rest of the range
- Maximum temperature of the liquid: 45°C
- Maximum suction depth: 8 m

#### MATERIALS

- Cast iron pump body
- Seal housing disc AISI 304
- Shaft in AISI 416
- Impeller and nozzle in PPO reinforced with fibreglass
- Mechanical seal in Carbon/Ceramic/NBR

#### TECHNICAL DATA

- Self-ventilated 2 pole asynchronous motor
- Class of insulation F
- IP44 Protection rating
- 230V ± 10% 50Hz single phase voltage  
230/400V ± 10% 50Hz three phase voltage
- Permanent capacitor inserted and thermo-amperometric protection with automatic reset incorporated for the single phase motor
- Protection under user's responsibility for the three phase version

#### TYPICAL APPLICATIONS

The base of the group is in galvanised steel as are the manifolds. The discharge manifold is set-up to gather two vertical membrane reservoirs. Mounted on them find two pressure switches, the electric control panel and a pressure gauge. On suction, each electric pump has an isolating valve and a non-return valve, with the possibility of connection to an air supply unit and has another isolating valve in discharge mode.

#### Protection and control panel with CE mark

- IMQ and VDE marked components
- Very low voltage auxiliary circuit
- Motor switch-on and switch-off are controlled by two pressure switches
- The connection to a float of minimum pressure pressure switch is possible in order to prevent functioning in conditions when there is no suction water
- A device is present that inverts the insertion order of the pumps at every start-up
- Power supply:
  - 230V, 50Hz single phase
  - 400V, 50 Hz three phase
- Direct start-up
- Power circuit protection fuse
- Auxiliary circuit protection fuse
- Protection rating IP 55
- Line general isolating switch with door lock
- Aut. - 0 - man. switches for each pump
- Circuit breaker protection reset
- LED indicator:
  - network presence
  - motor running
  - level alarm
  - motor in protection mode (for three phase version only)
- Alarm output set-up
- On request, special version control panels can be used

#### FUNCTIONING PRINCIPLES

The withdrawal or however the escape of water from the system with the pumps at a standstill, causes the pressure to drop and the consequent closure of the pressure switch contact with highest calibration, which determines start-up of the first electric pump. If the outlet discharge exceeds the flow rate of a pump, the pressure continues to drop until it causes the closure of the contact of the second pressure switch and the start-up of the second pump. The end of the distribution of the reduction of the outlet discharge leads to the pressure in the system rising, with opening of the pressure switch contacts and staggered pumps stops. The inversion of the ignition order of the two motors reduces the number of hourly start-ups of the individual pumps and consequently allows a homogenous use of the same. By connecting a float or minimum pressure pressure switch to the control panel (whether for withdrawal from the primary collection reservoir or from the hydraulic circuit), the most frequent cause of electric pump breakdown is prevented: the lack of water at suction.





# 2GP AGA

## DOMESTIC PRESSURE BOOSTING

### 2GP AGA 1.00 range PERFORMANCE CURVES

(according to ISO 9906 Attachment A)

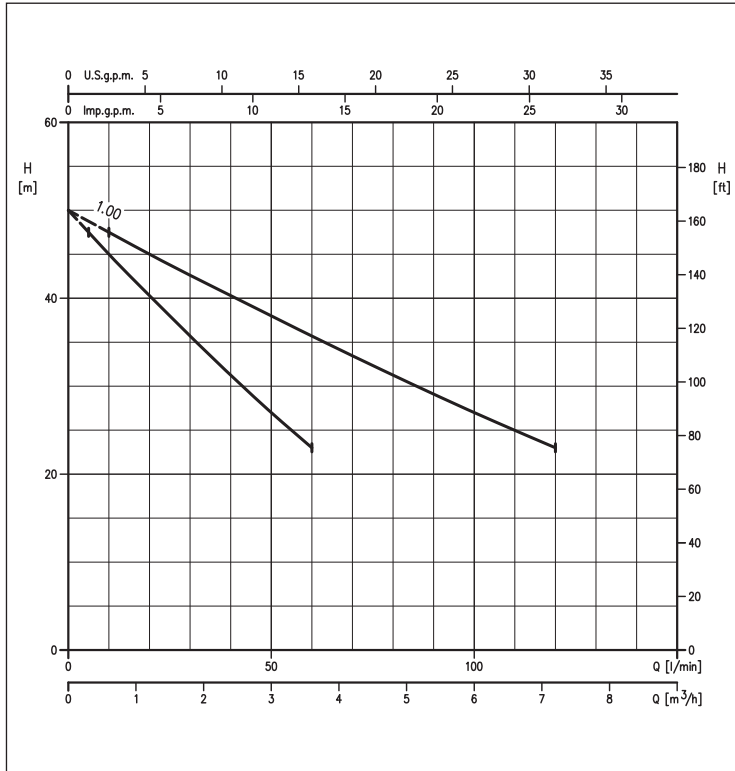

### 2GP AGA 1.50 - 2.00 - 3.00 range PERFORMANCE CURVES

(according to ISO 9906 Attachment A)

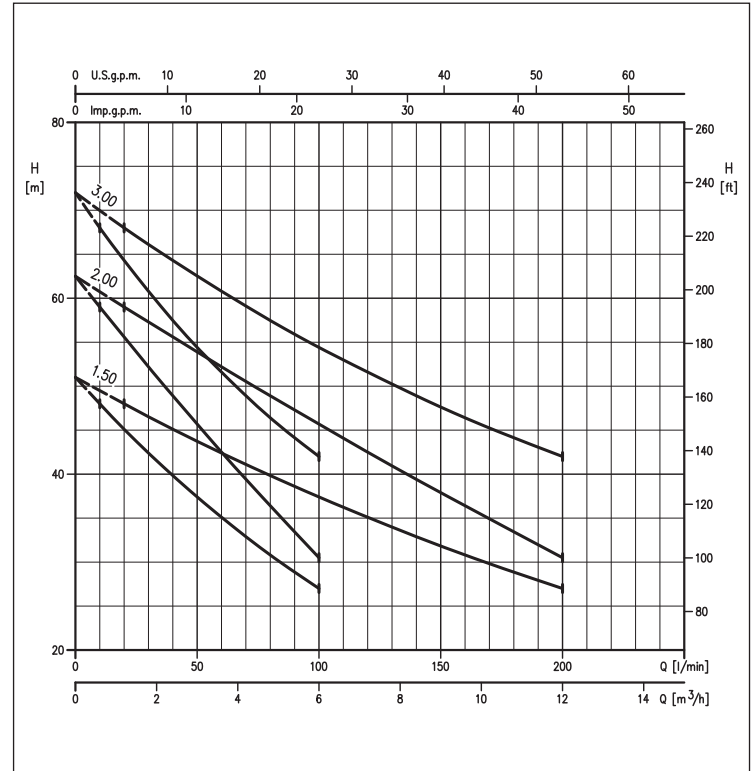

### PERFORMANCE TABLE AND ELECTRIC DATA OF THE TWO PUMPS FUNCTIONING SIMULTANEOUSLY

Model		[kW]	Max absorption [A]		l/min m³/h	Q=Flow rate								
230V single phase	400V three-phase		230V single phase	400V three-phase		10 0,6	20 1,2	40 2,4	60 3,6	90 5,4	100 6	120 7,2	160 9,6	200 12
		H=Head [m]												
AGA 1.00 M	AGA 1.00 T	0.75+0.75	11	4,2	47,5	45	40,3	35,7	29,1	27	23	-	-	
AGA 1.50 M	AGA 1.50 T	1.1+1.1	16,2	6	-	48	45,1	42,4	38,6	37,4	35,1	30,8	27	
AGA 2.00 M	AGA 2.00 T	1.5+1.5	19,6	7,2	-	59	55,6	52,2	47,3	45,7	42,5	36,4	30,5	
-	AGA 3.00 T	2.2+2.2	-	9,4	-	68	64,3	60,8	55,9	54,4	51,6	46,4	42	

### DIMENSIONS

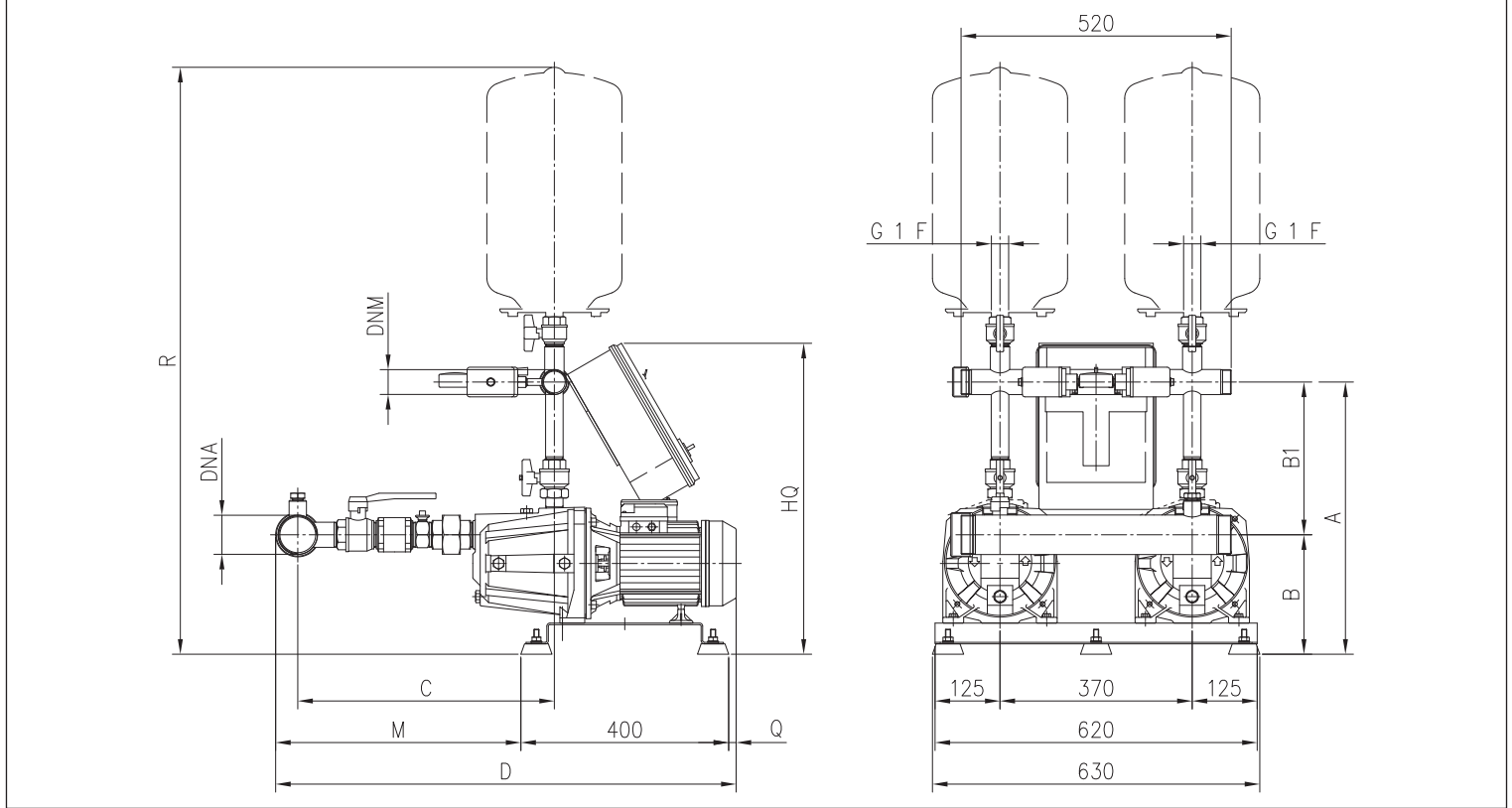

### DIMENSIONS TABLE

Model	Dimensions [mm]											Weight [kg]		
	A	B	B1	C	[2]	D	[1]	M	R	[2]	Q		[1]	HQ
2GP AGA 1.00 (M)	485	210	275	415	770	770	370	1090	-	-	560	G2	G1½	51,0
2GP AGA 1.50 (M)	525	230	295	495	870	870	470	1130	-	-	600	G2½	G1½	78,0
2GP AGA 2.00 (M)	525	230	295	495	885	870	470	1130	15	-	600	G2½	G1½	78,0
2GP AGA 3.00	525	230	295	495	-	885	470	1130	-	15	600	G2½	G1½	80,0

[1]= Three-phase only

[2]= Single phase only

