

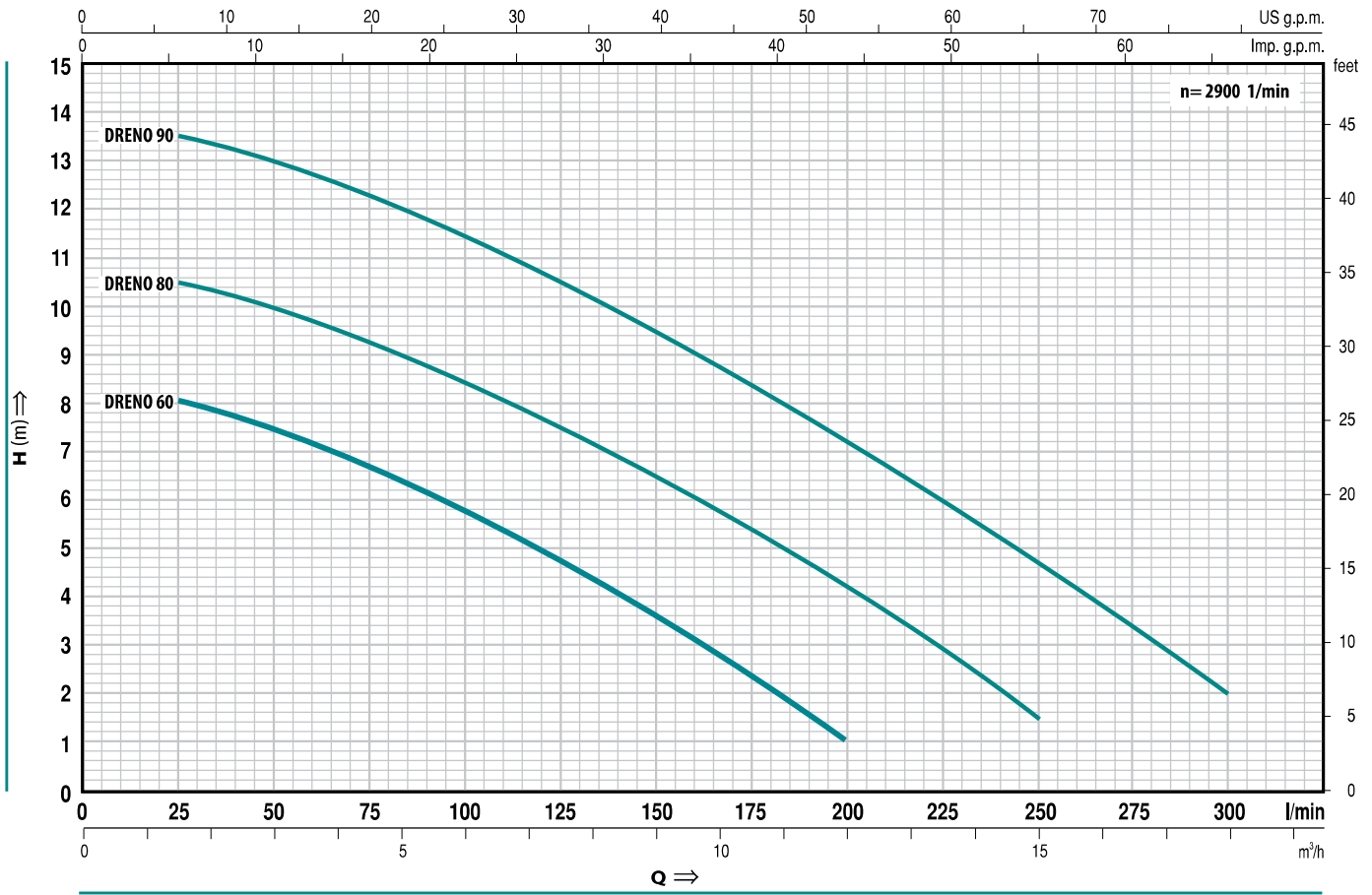

DRENO

DRAINAGE submersible pumps



Q = Flow rate H = Total manometric head

Tolerance of the performance curves according to EN ISO 9906 App. A.

TYPE	POWER		m³/h l/min	0	1.5	3.0	4.5	6.0	7.5	9.0	10.5	12.0	13.5	15.0	16.5	18.0
	kW	HP		0	25	50	75	100	125	150	175	200	225	250	275	300
DRENO 60M	0.37	0.50	H metres	8.5	8	7.5	6.5	5.5	4.8	3.5	2.5	1				
DRENO 80M	0.50	0.70		11	10.5	10	9	8.5	7.5	6.5	5.5	4	2.5	1.5		
DRENO 90M	0.60	0.85		14	13.5	13	12.2	11.5	10.5	9.5	8.3	7	5.7	4.5	3.2	2

DIMENSIONS AND WEIGHTS

TYPE	PORT DN	DIMENSIONS mm									kg
		a	b	c	h	h1	d	e	p	∅	
DRENO 60M	1 1/2"	110	81	142	310	66	15	adjustable	450	450	9.8
DRENO 80M											10.4
DRENO 90M											11.3





RANGE OF PERFORMANCE

Flow rate up to 300 l/min (18 m³/h)

Head up to 14 m

LIMITS OF USE

Depth up to 5 m

Liquid temperature up to + 40°C

Passage of suspended solid bodies up to
Ø 10 mm

Drainage level 15 mm from the bottom

For continuous duty: minimum immer-
sion 180 mm from pump base

INSTALLATION AND USE

DESIGNED FOR DRAINING CLEAR OR SLIGHTLY DIRTY WATER, THEY ARE SUITABLE FOR DOMESTIC USE, FOR DRAINING FLOODED AREAS SUCH AS CELLARS AND FOR EMPTYING TANKS AND RESERVOIRS; THEY ARE OUTSTANDING IN BOTH THEIR SIMPLICITY OF INSTALLATION AND THEIR RELIABILITY IN FIXED INSTALLATIONS WITH AUTOMATIC OPERATION.

GUARANTEE 2 YEARS subject to our general terms of sale.

CONSTRUCTION CHARACTERISTICS

- **DELIVERY BODY:** cast iron, with threaded port ISO 228/1.
- **MOTOR CASING:** stainless steel AISI 304.
- **SUCTION GRID:** stainless steel AISI 304.
- **IMPELLER:** open type, in technopolymer.
- **MOTOR SHAFT:** stainless steel EN 10088-3 - 1.4104.
- **MECHANICAL SEAL:** ceramic - graphite - NBR.
- **MOTOR:** submersible asynchronous single-phase for continuous duty.
- **DRENO M:** single-phase 220÷240 V - 50 Hz with capacitor and thermal overload protector.
- **INSULATION:** class F.
- **PROTECTION:** IP 68.

STANDARD FEATURES:

- Float switch.
- Neoprene power cable "H07 RN-F"
- length 5 metres with Schuko plug.

OPTIONS ON REQUEST

- ⇒ special mechanical seal
- ⇒ 10 metres power cable. N.B. required for outdoor use to comply with standard EN 60335-2-41
- ⇒ versions without float switch
- ⇒ other voltages or frequency 60 Hz



CONSTRUCTION AND SAFETY STANDARDS

EN 60 335-1

EN 60034-1

IEC 335-1

IEC 34-1

CEI 61-150

CEI 2-3



DIMENSIONS

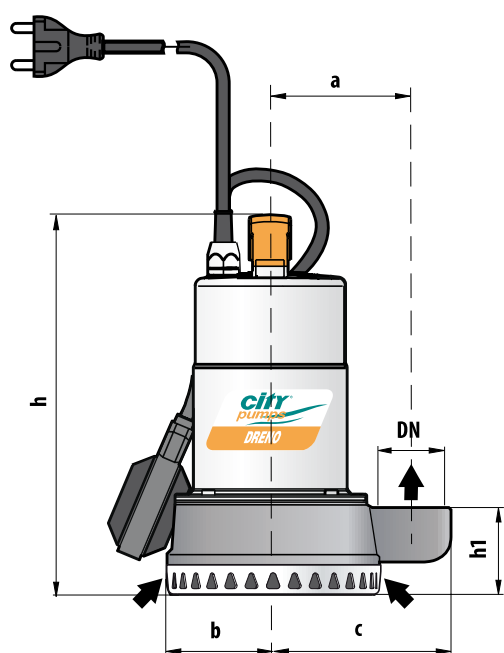

Typical single-phase installation

