

Teknoloji	: Pabuç tip (yağlı)
Model	: RBT70A41
Kapasite (max)	: 1.6...13.7 m ³ /saat
Kapasite (litre / rpm)	: 6.7 litre
Pompa çalışma hızı	: 4...34 rpm
Basınç	: 15 bar (max)
Gövde malzemesi	: Dökme demir
Hortum iç çapı	: 65 mm
Katı partikül geçirgenliği	: 16.3 mm
Pompa Bağlantı çapı	: DN 65
Ağırlık (motorsuz)	: 530 kg

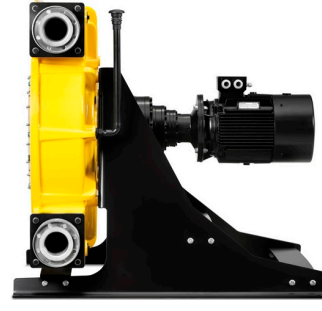

Boyser
peristaltic pumps
RBT SERIES

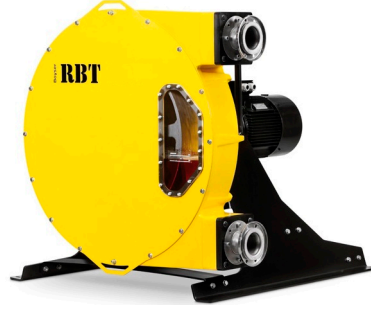

* Pompa hortum malzemesi prosese göre aşağıdaki farklı malzemelerden seçilebilir.

NR
NBR
EPDM
NR-A
NBR-A
HYPALON

** Elektrik motoru proses ve basınca göre 3 - 7.5 kW aralığında seçilmektedir.

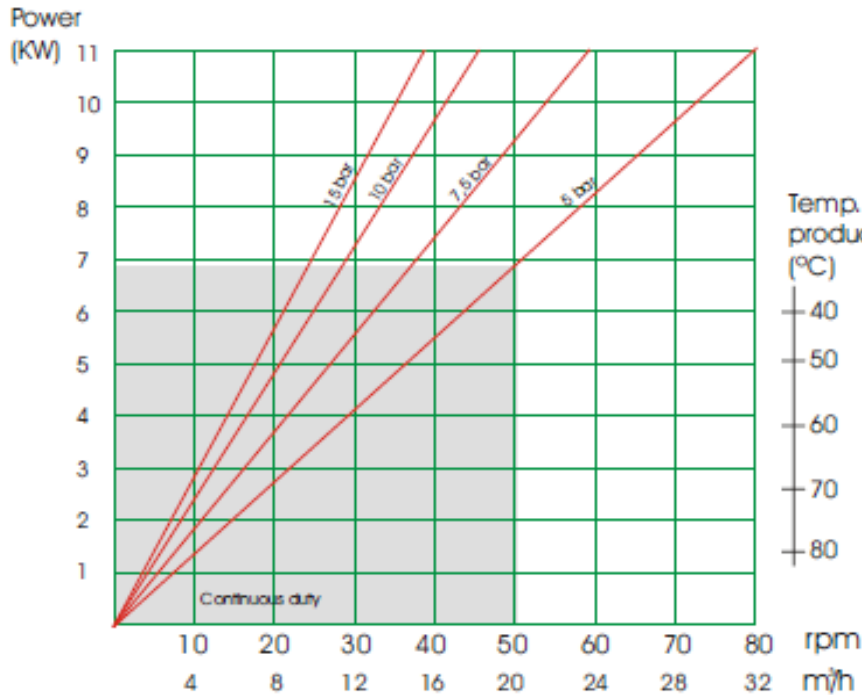

RBT-70 Dimensions

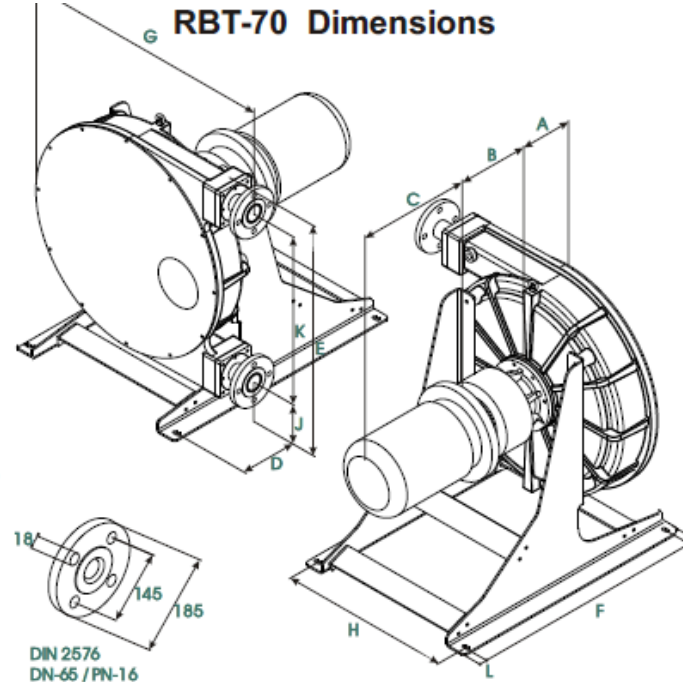

A	B	C	D	E	F	G	H	I	J	K	L
215	*	*	250	1124	1065	1100	790	40	240	784	40

* To confirm according type and power drive.



