

Teknoloji	: Pabuç tip (yağlı)
Model	: RBT60A16
Kapasite (max)	: 12.6 m ³ /saat
Kapasite (litre / rpm)	: 3.61 litre
Pompa çalışma hızı	: 58 rpm
Basınç	: 15 bar (max)
Gövde malzemesi	: Dökme demir
Hortum iç çapı	: 57 mm
Katı partikül geçirgenliği	: 14.3 mm
Pompa Bağlantı çapı	: DN 65
Ağırlık (motorsuz)	: 252 kg



Boyser
peristaltic pumps
RBT SERIES



* Pompa hortum malzemesi prosese göre aşağıdaki farklı malzemelerden seçilebilir.

NR
NBR
EPDM

** Elektrik motoru proses ve basınca göre 3 - 7.5 kW aralığında seçilmektedir.

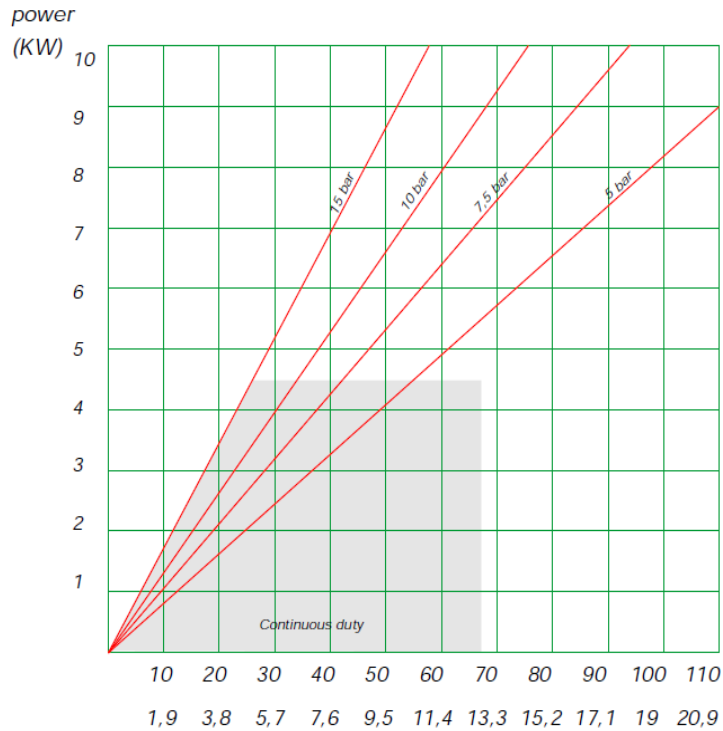

RBT-60 Dimensions

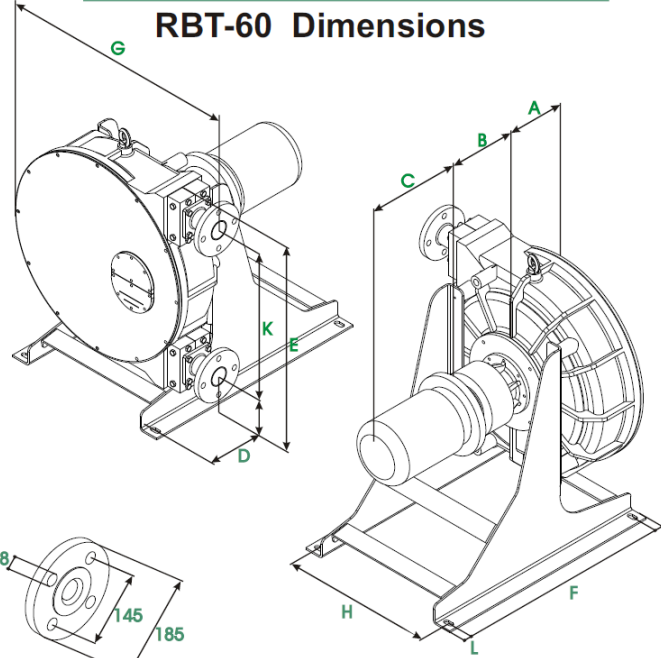

DIN 2576
DN-65 / PN-16

A	B	C	D	E	F	G	H	I	J	K	L
215	*	*	111	805	740	735	500	25	210	610	25

* To confirm according type and power driver.



