

**Boyer  
peristaltic pumps  
RBT SERIES**

Teknoloji	: Pabuç tip (yağlı)
Model	: RBT40A15
Kapasite (max)	: 3830 Litre/saat
Kapasite (rpm)	: 1.33 litre
Pompa çalışma hızı	: 48 rpm
Motor	: 2.2 kW
Motor Frekans aralığı	: 20 - 60 Hz
Basınç	: 15 bar (max)
Gövde malzemesi	: Dökme demir
Hortum iç çapı	: 40 mm
Katı partikül geçirgenliği	: 10 mm
Pompa Bağlantı çapı	: DN 40
Ağırlık (motorsuz)	: 150 kg

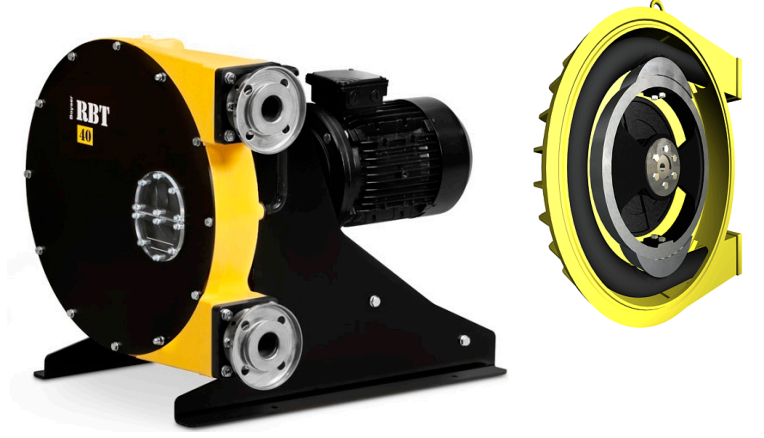

\* Pompa hortum malzemesi prosese göre aşağıdaki farklı malzemelerden seçilebilir.

NR  
NBR  
EPDM

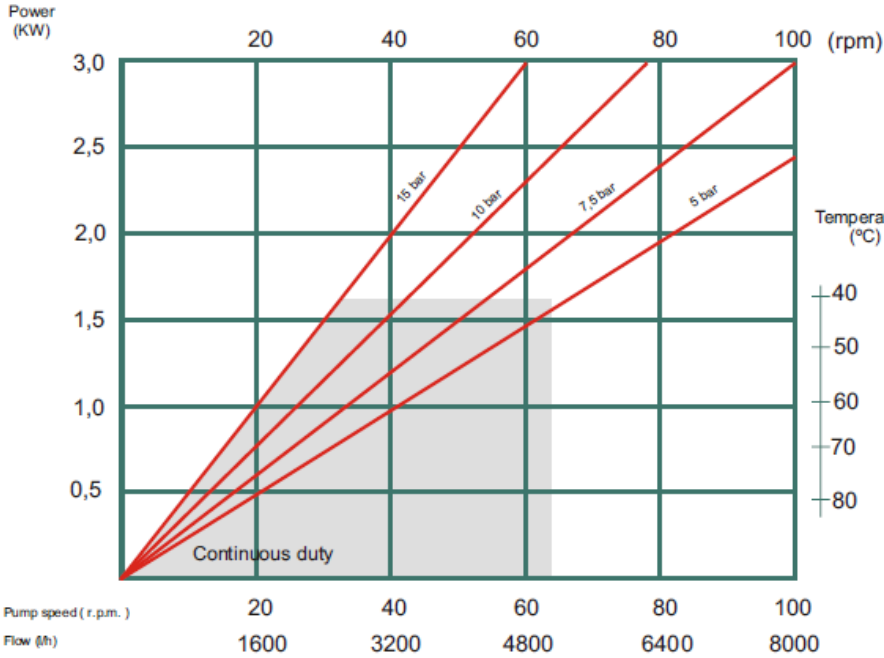

Industrial Peristaltic pumps  
**RBT-40 Dimensions**

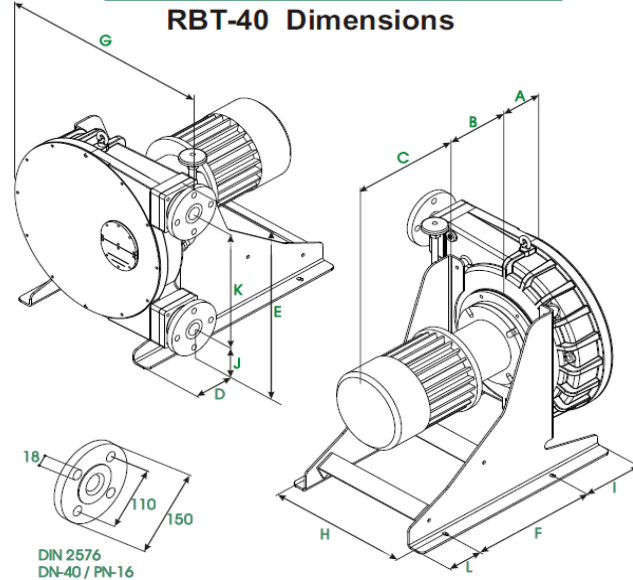

A	B	C	D	E	F	G	H	I	J	K	L
151	*	*	79	645	415	633	456	200	159	412	116

\* To confirm according type and power driver.





**boyser**<sup>®</sup>

**ERTEK**  
[www.ertek.com](http://www.ertek.com)

**Ertek Yapı ve Makina Endüstri Ekipmanları San. ve Tic. Ltd. Şti.**  
Halkapınar Mah. Pamuk Plaza İş Merkezi 1082 Sokak No: 3 M 35170  
Yenişehir Konak / İZMİR Tel: (0232) 469 43 53 Faks: (0232) 457 46 51  
[www.ertek.com](http://www.ertek.com) • [info@ertek.com](mailto:info@ertek.com)

