

**Boyser
peristaltic pumps
RBT SERIES**

Teknoloji	: Pabuç tip (yağlı)
Model	: RBT25BA43
Kapasite (max)	: litre/saat
Motor.(Kw)	: 1.1 Kw
Pompa çalışma hızı	: 55 rpm
Basınç	: 15 bar (max)
Gövde malzemesi	: Dökme demir
Hortum iç çapı	: 25 mm
Katı partikül geçirgenliği	: 6.3 mm
Pompa Bağlantı çapı	: DN 25
Ağırlık (motorsuz)	: 57 kg

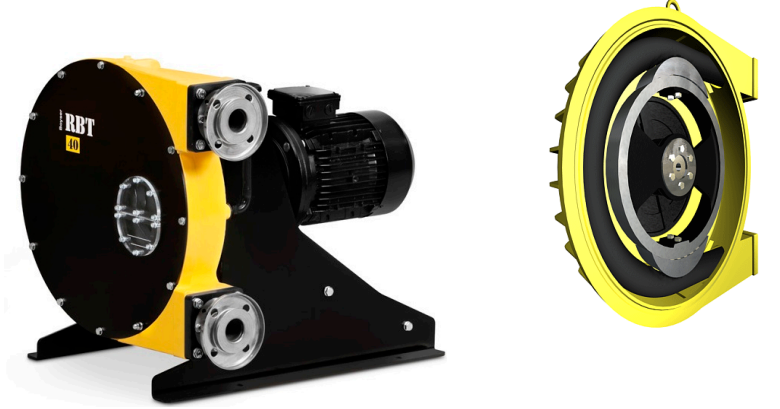

* Pompa hortum malzemesi prosese göre aşağıdaki farklı malzemelerden seçilebilir.

NR
NBR
EPDM

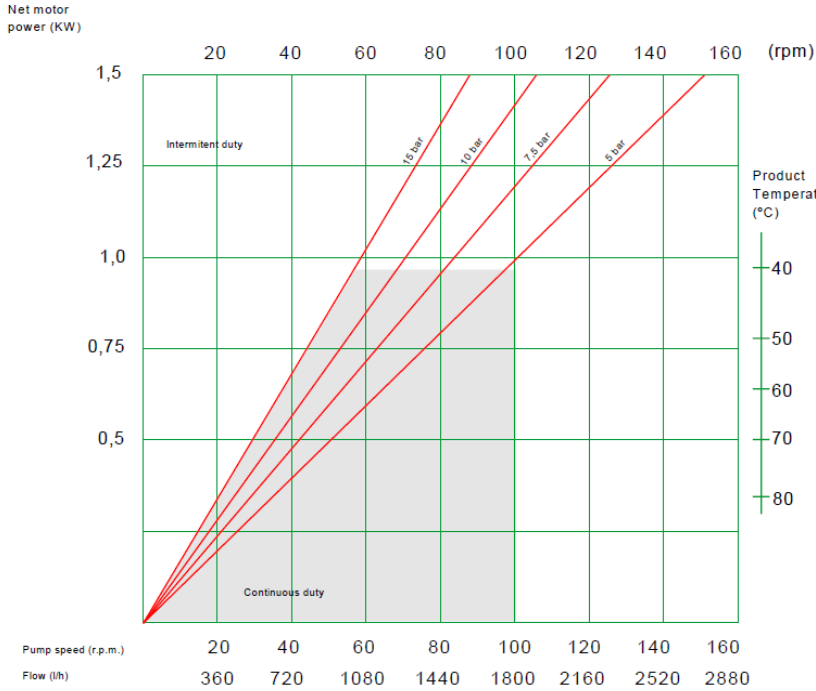

Industrial Peristaltic pumps
RBT-25B Dimensions

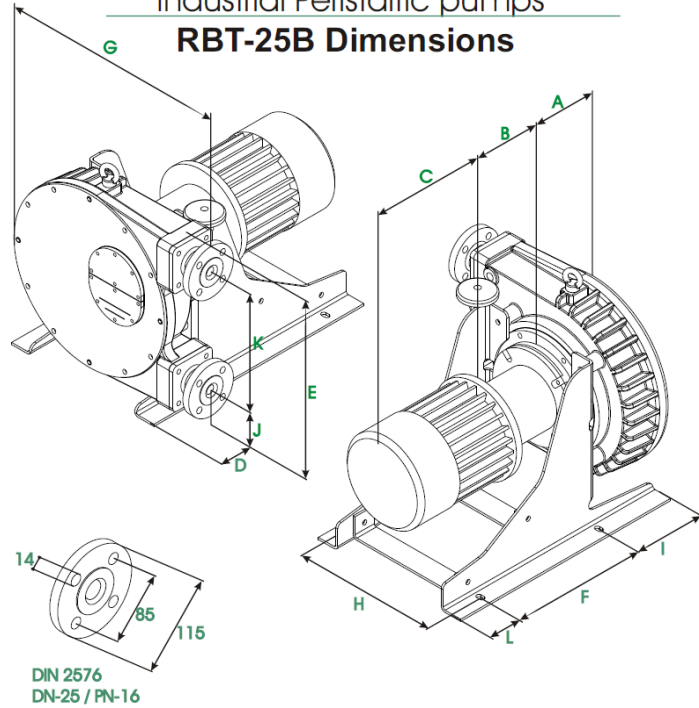

A	B	C	D	E	F	G	H	I	J	K	L
127,5	*	*	60	425	305	471	305	160	100	262	75

* To confirm according type and power driver.



boyser®

ERTEK
www.ertek.com

Ertek Yapı ve Makina Endüstri Ekipmanları San. ve Tic. Ltd. Şti.
Halkapınar Mah. Pamuk Plaza İş Merkezi 1082 Sokak No: 3 M 35170
Yenişehir Konak / İZMİR Tel: (0232) 469 43 53 Faks: (0232) 457 46 51
www.ertek.com • info@ertek.com

