

**BOYSER RBT-100 HORTUM POMPA**

Tip	: Shoes Tip (Yağlı)
Model	: RBT-100
Kapasite	: 0 – 36 m <sup>3</sup> /h
Basınç	: Max. 15 bar
Motor	: Max. 18,5 kW – 1450 d/d
Devir	: Max. 30 d/d
Elektrik Bağlantısı	: 3faz – 230/400V – 50Hz
Gövde Malzemesi	: Dökme demir
Hortum Malzemesi	: NBR
Sıcaklık	: -20 °C, +80 °C
Bağlantı	: DN 100

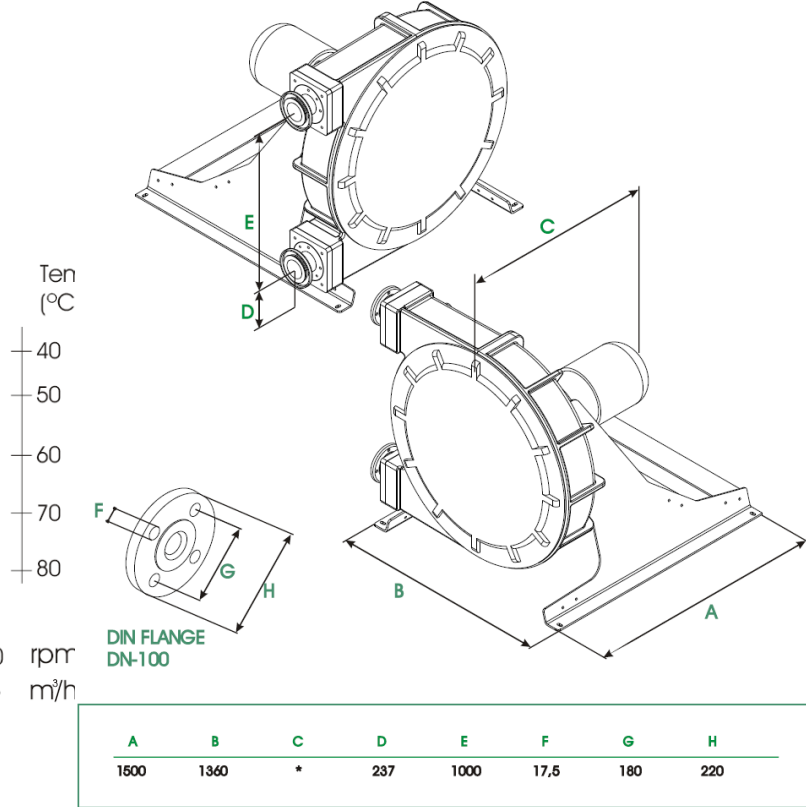

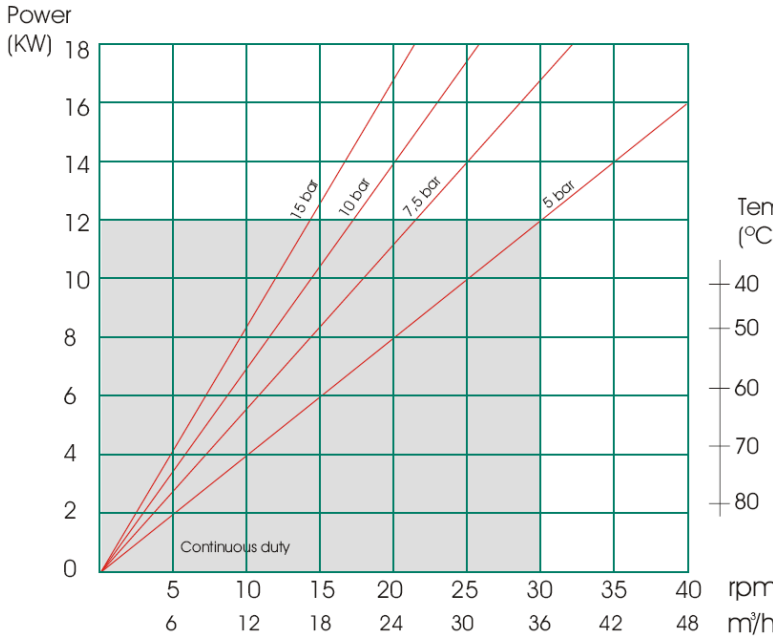
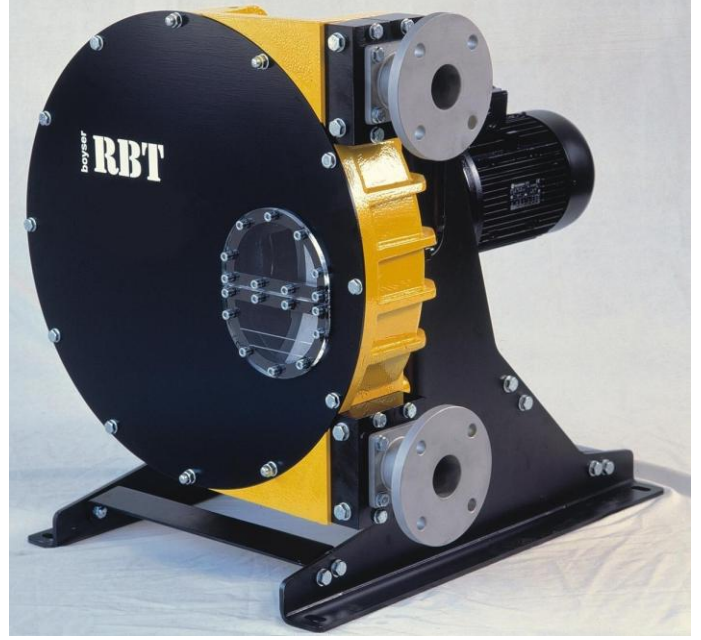

**boyser**<sup>®</sup>

**ERTEK**  
[www.ertek.com](http://www.ertek.com)

**Ertek Yapı ve Makina Endüstri Ekipmanları San. ve Tic. Ltd. Şti.**  
Halkapınar Mah. Pamuk Plaza İş Merkezi 1082 Sokak No: 3 M 35170  
Yenişehir Konak / İZMİR Tel: (0232) 469 43 53 Faks: (0232) 457 46 51  
[www.ertek.com](http://www.ertek.com) • [info@ertek.com](mailto:info@ertek.com)

