

Teknoloji	: Roller tip (yağsız)
Model	: FMP-70
Kapasite (max)	: 18,5 m ³ /saat
Motor (Kw)	: 5.5 Kw
Pompa çalışma hızı	: 46 rpm
Basınç	: 8 bar (max)
Gövde malzemesi	: Dökme demir
Hortum iç çapı	: 65 mm
Katı partikül geçirgenliği	: 16,3 mm
Pompa Bağlantı çapı	: DN 65
Ağırlık (motorsuz)	: 440 kg

* Pompa hortum malzemesi prosese göre aşağıdaki farklı malzemelerden seçilebilir.

NR
NBR
EDDM
NR-A
NBR-A
HYPALON

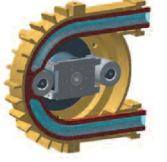
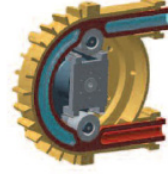
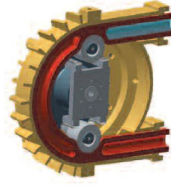

Boyer
peristaltic pumps
FMP SERIES

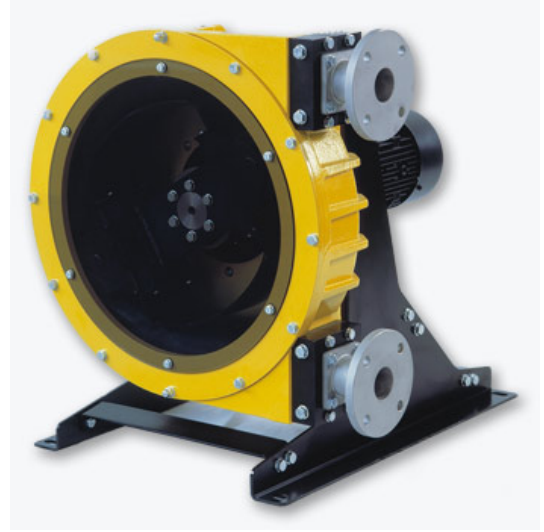

FMP-70 Dimensions

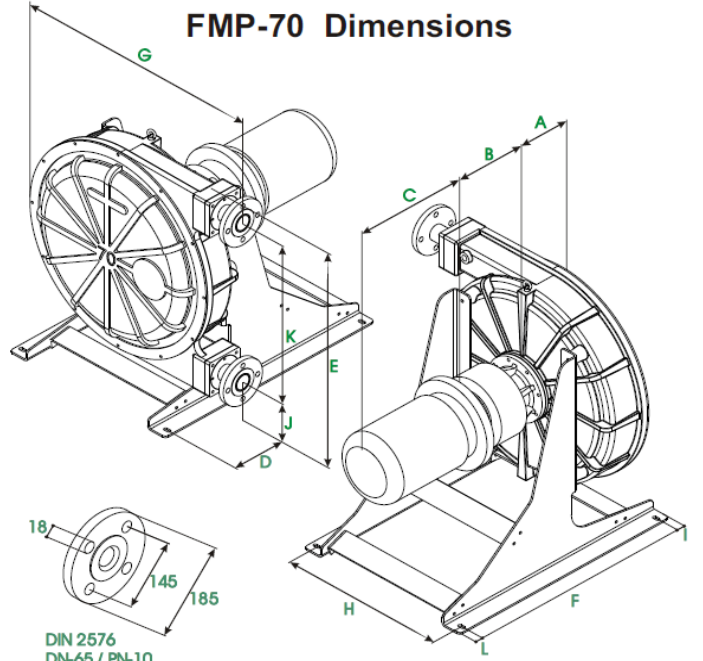

A	B	C	D	E	F	G	H	I	J	K	L
215	*	*	250	1124	1065	1100	790	40	240	784	40

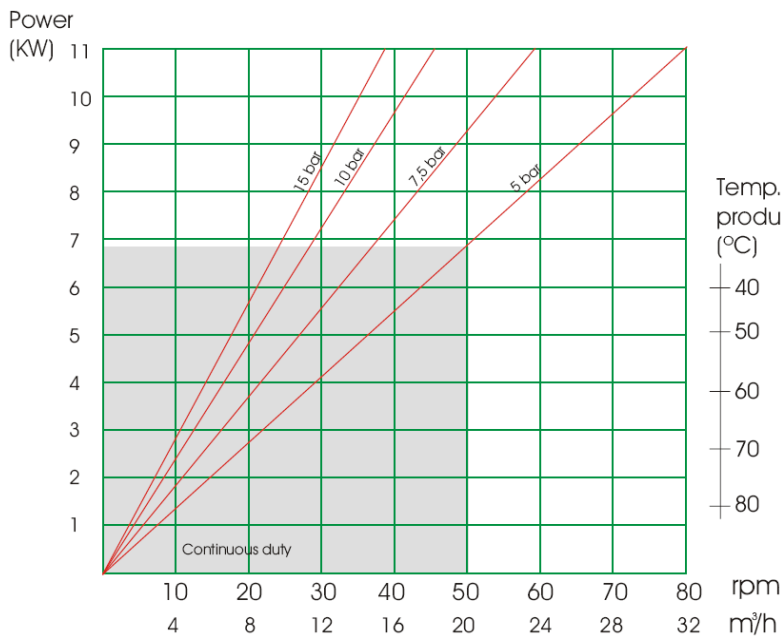

boyser®

ERTEK
www.ertek.com

Ertek Yapı ve Makina Endüstri Ekipmanları San. ve Tic. Ltd. Şti.
Halkapınar Mah. Pamuk Plaza İş Merkezi 1082 Sokak No: 3 M 35170
Yenişehir Konak / İZMİR Tel: (0232) 469 43 53 Faks: (0232) 457 46 51
www.ertek.com • info@ertek.com

