

Teknoloji	: Roller tip (yağsız)
Model	: FMP-30
Kapasite (max)	: 2600 litre/saat
Kapasite (rpm)	: 0.433 litre
Pompa çalışma hızı	: 100 rpm (max)
Basınç	: 8 bar (max)
Gövde malzemesi	: Dökme demir
Hortum iç çapı	: 28 mm
Katı partikül geçirgenliği	: 7 mm
Pompa Bağlantı çapı	: 1 ¼ "
Ağırlık (motorsuz)	: 62 kg

* Pompa hortum malzemesi prosese göre aşağıdaki farklı malzemelerden seçilebilir.

NR
NBR
EDDM
NR-A
NBR-A
HYPALON
NORPRENE

** Elektrik motoru proses ve basınca göre 0.25 - 0.75 kW aralığında seçilmektedir.

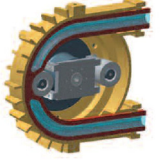
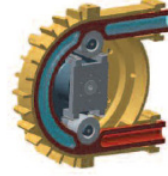
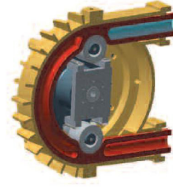
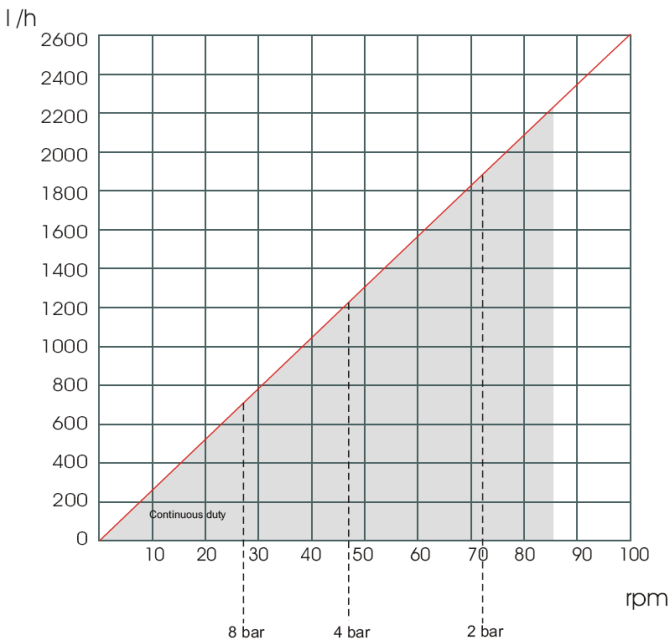

Boyer
peristaltic pumps
FMP SERIES

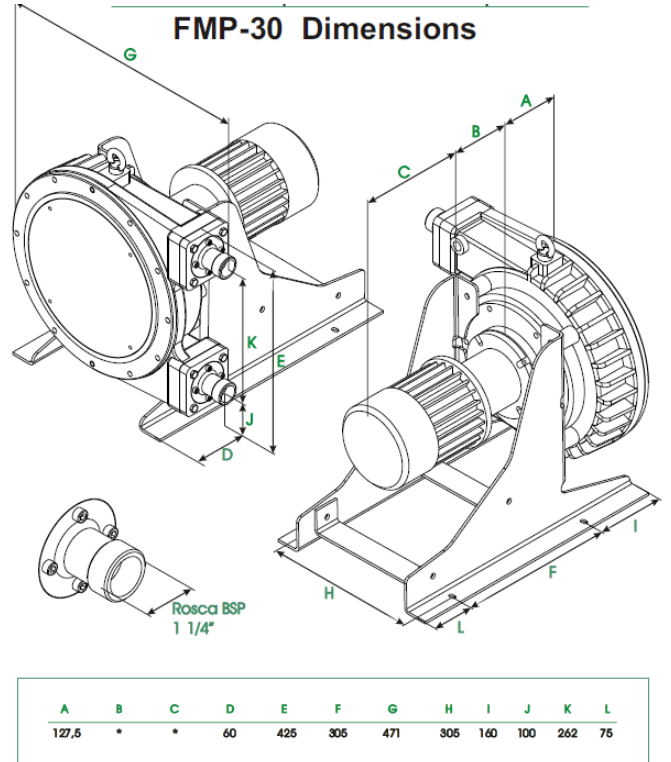
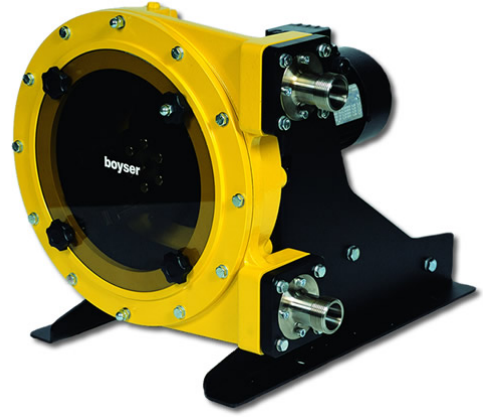



boyser[®]

ERTEK
www.ertek.com

Ertek Yapı ve Makina Endüstri Ekipmanları San. ve Tic. Ltd. Şti.
Halkapınar Mah. Pamuk Plaza İş Merkezi 1082 Sokak No: 3 M 35170
Yenişehir Konak / İZMİR Tel: (0232) 469 43 53 Faks: (0232) 457 46 51
www.ertek.com • info@ertek.com

