

BOYSER AMP-19 HORTUM POMPA

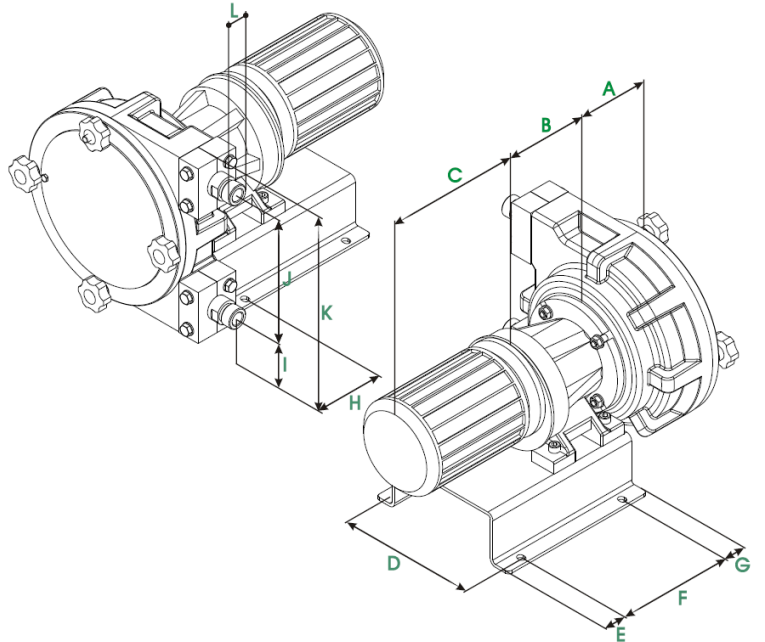

Tip	: Roller Tip (Yağsız)
Model	: AMP-19
Kapasite	: 0 - 517 l/h
Basınç	: Max. 8 bar
Motor	: Max. 0,37 Kw - 1450 d/d
Devir	: Max. 70 d/d
Elektrik Bağlantısı	: 3faz – 230/400V – 50Hz
Gövde Malzemesi	: Dökme demir
Hortum Malzemesi	: NBR
Sıcaklık	: -20 °C, +80 °C
Bağlantı	: 1"

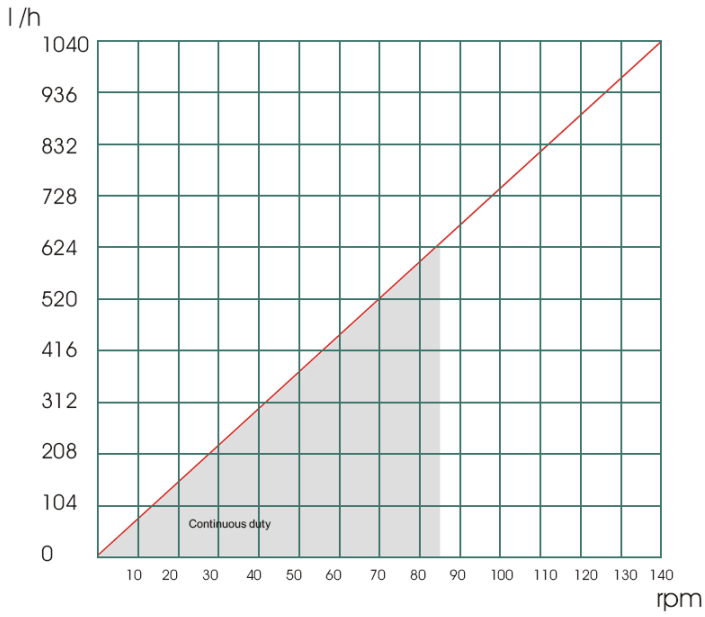
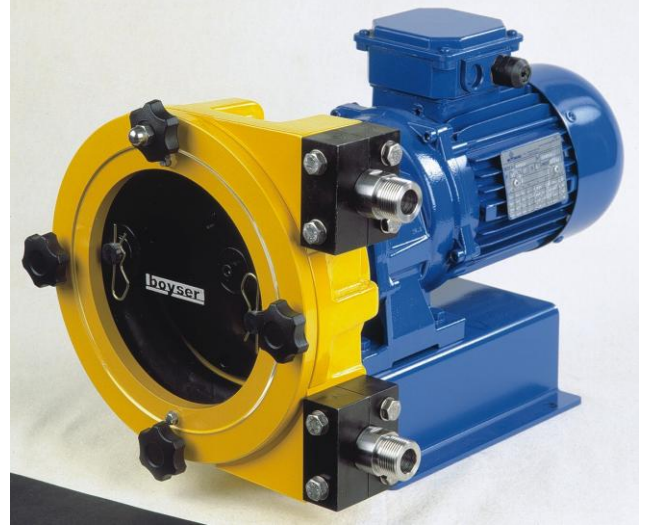

A	B	C	D	E	F	G	H	I	J	K	L
119	*	*	190	30	160	30	75	60	170	265	1" BSP



