

Teknoloji	: Roller tip (yağsız)
Model	: AMP-19/C
Kapasite (max)	: 1040 litre/saat
Kapasite (rpm)	: 0.123 litre
Pompa çalışma hızı	: 140 rpm (max)
Basınç	: 2 bar (max)
Gövde malzemesi	: Dökme demir
Hortum iç çapı	: 19 mm
Katı partikül geçirgenliği	: 4,8 mm
Pompa Bağlantı çapı	: 1"
Ağırlık (motorsuz)	: 13 kg

* Pompa hortum malzemesi prosese göre aşağıdaki farklı malzemelerden seçilebilir.
NORPRENE
TAYGON

** Elektrik motoru proses ve basınca göre 0.18 - 0.37 kW aralığında seçilmektedir

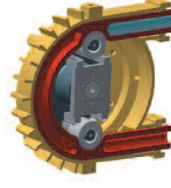

Boyser peristaltic pumps AMP SERIES

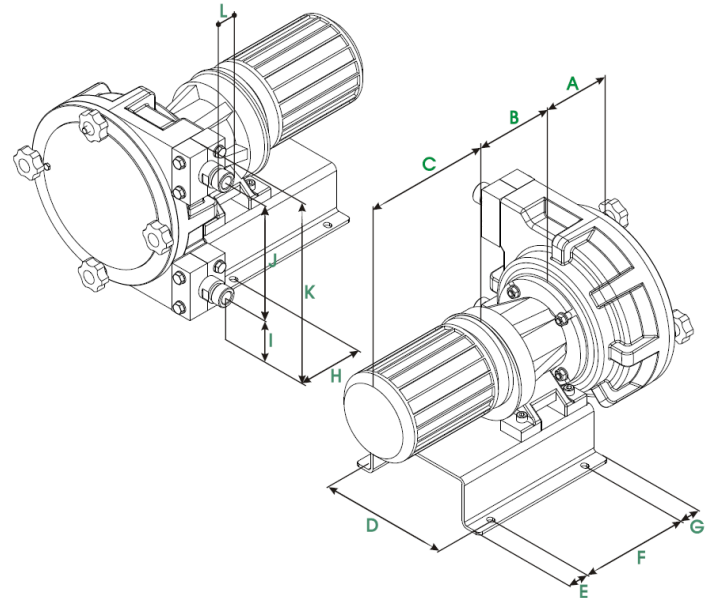
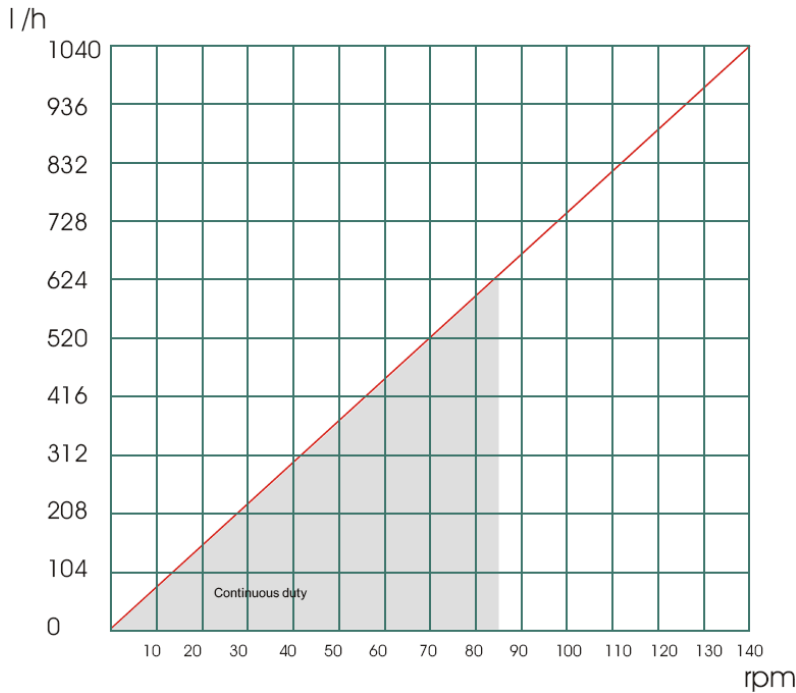
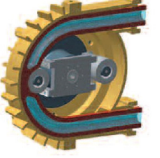
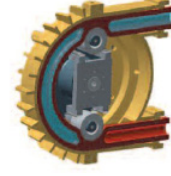

A	B	C	D	E	F	G	H	I	J	K	L
119	*	*	190	30	160	30	75	60	170	265	1" BSP



