

Teknoloji	: Roller tip (yağsız)
Model	: AMP-16/D
Kapasite (max)	: 469 litre/saat
Motor (Kw)	: 0.37Kw
Pompa çalışma hızı	: 85 rpm
Basınç	: 8 bar (max)
Gövde malzemesi	: Dökme demir
Hortum iç çapı	: 16 mm
Katı partikül geçirgenliği	: 4 mm
Pompa Bağlantı çapı	: 3/4 "
Ağırlık (motorsuz)	: 13 kg

\* Pompa hortum malzemesi prosese göre aşağıdaki farklı malzemelerden seçilebilir.

NR  
NBR  
EDDM  
NR-A  
NBR-A  
HYPALON  
NORPRENE

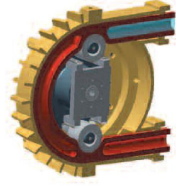

## Boyser peristaltic pumps AMP SERIES

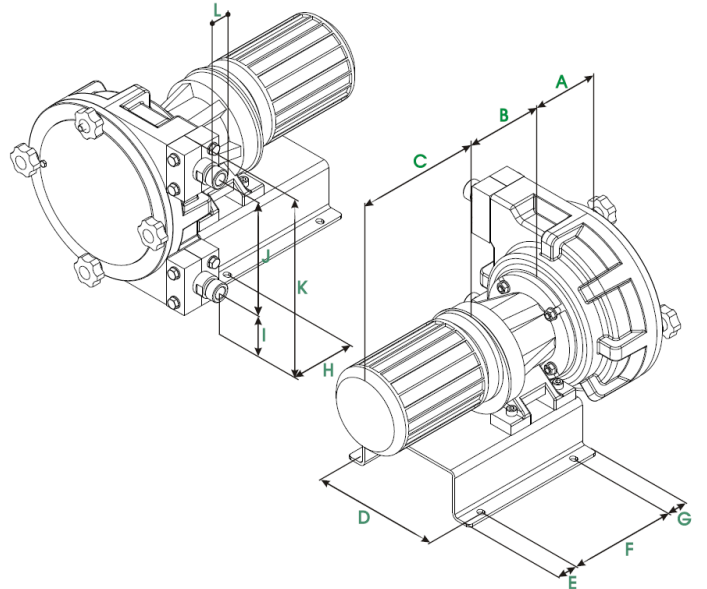
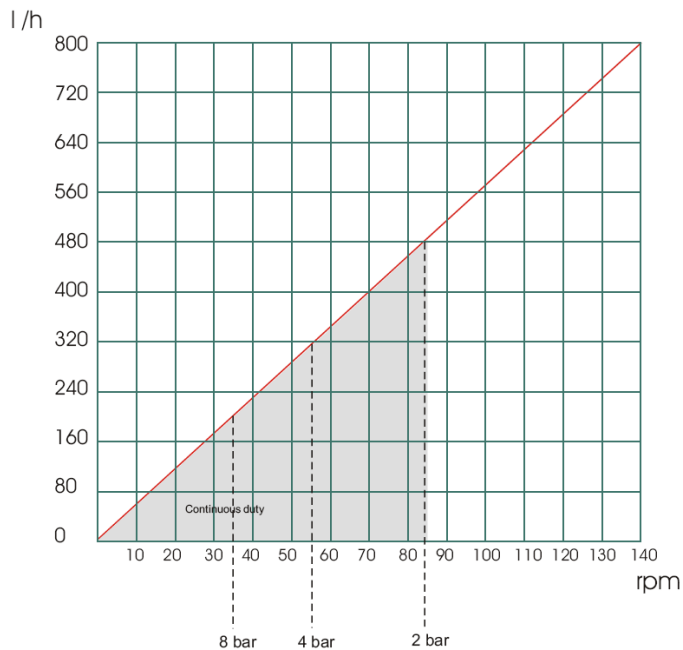
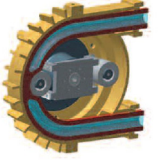
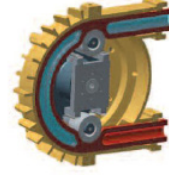

A	B	C	D	E	F	G	H	I	J	K	L
119	*	*	190	30	160	30	75	60	170	265	3/4" BSP



