

## **BOYSER AMP-16 HORTUM POMPA**

Tip	: Roller Tip (Yağsız)
Model	: AMP-16
Kapasite	: 0 - 221 l/h
Basınç	: Max. 8 bar
Motor	: Max 0,25 Kw - 1450 d/d
Devir	: Max. 40 d/d
Elektrik Bağlantısı	: 3faz – 230/400V – 50Hz
Gövde Malzemesi	: Dökme demir
Hortum Malzemesi	: NBR
Sıcaklık	: -20 °C, +80 °C
Bağlantı	: 3/4"

**boyser**<sup>®</sup>

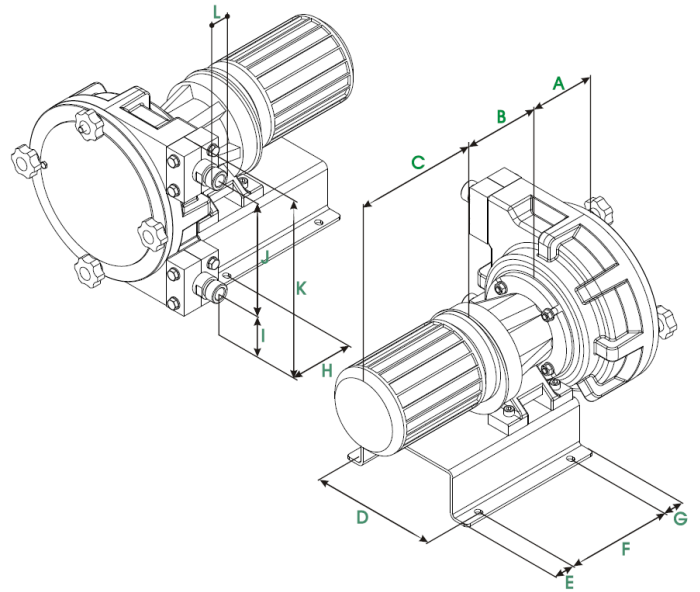
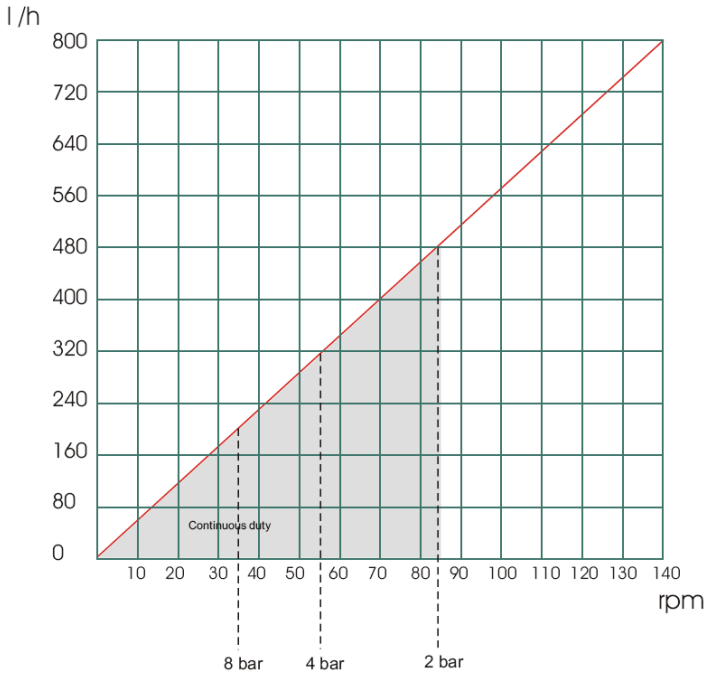
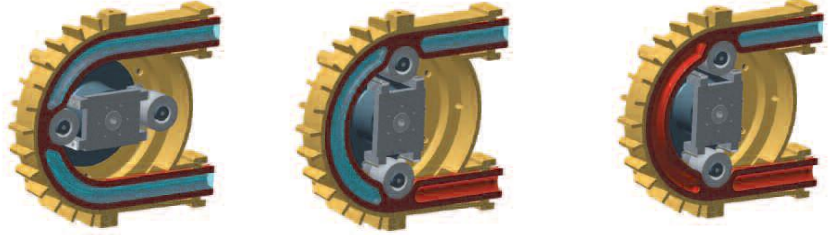

A	B	C	D	E	F	G	H	I	J	K	L
119	*	*	190	30	160	30	75	60	170	265	3/4" BSP



